



wieland

Electrical
Connections



Application Manual Safety

**Application Examples for
Planning/Configuring Safety-related
Equipment for Machines and Plants**



Preface of the employers' liability insurance association (Berufsgenossenschaft)

The development of safety switching devices over the last 15 years has been such that hardly any limits for their application remain. This manual gives users the information needed to install the safety switching devices consistent with the needs of the particular application.

There are technical solutions for different applications, whether it be for emergency stop switching devices, safety mat evaluation devices, or evaluation units as part of a two-hand control.

Over the years the development of safety switching devices has been accompanied by the "Prüf- und Zertifizierungsstelle des Fachausschuss Elektrotechnik" [English translation: testing and certification body of the committee of experts for electronics]. Correlation with the valid product standards has been checked via a conformity assessment procedure; the testing guideline "GS-ET-20" was developed especially for the various safety switching devices.

This testing guideline defines the specific testing requirements for the safety switching devices. In recent years, the rapidly developing technology has required constant updating of the testing requirements, resulting in further development of the safety switching devices. The discourse regarding the safety-oriented behavior of modules is important to mention – changes in international standards must be taken into account.

In the upcoming years, the previous categorization according to DIN EN 954-1:1996 will be systematically replaced with the SIL, SILCL and/or the PL classification – all terms whose clarity and acceptance still have to be established with the users of the safety switching devices themselves. One of the future challenges of the testing and certification body of the committee of experts for electronics will be working together effectively with the producers of safety switching devices.

Ute Schneider,
Testing and Certification Body of the Committee of Experts
for Electronics

October 2006

Introduction

- I • 2 **User's Manual Information**
- I • 4 **Overview According to Device Types**
- I • 8 **Overview According to Application Number**

I

Application Examples

- 1 • 1 **Emergency Stop**
Single- or two-channel emergency stop monitors, categories 2, 3 and 4, stop categories 0 and 1
- 2 • 1 **Safety Gate**
Single-channel or two-channel safety gate monitors, categories 2, 3 and 4, stop categories 0 and 1
- 3 • 1 **Light Curtain**
ESPE type 4, muting sensors, ESPE type 2, categories 3 and 4, stop category 0
- 4 • 1 **Two-hand Control**
Two-channel, two-hand control type III C, category 4, stop category 0
- 5 • 1 **Safety Mat**
Single-channel or two-channel safety mat monitors, categories 2 and 3, stop category 0
- 6 • 1 **Lift**
Two-channel position monitoring of a lift cage
- 7 • 1 **Combustion Plant**
Combustion control contact expansion, single-channel monitor

1

2

3

4

5

6

7

Appendix

- A • 1 **Standards and Regulations**
- A • 6 **Safety Technology Terms**
- A • 10 **Part Numbers**
- A • 14 **Overview of Devices**

A

I Introduction

Wieland Electric Safety Switching Devices for Various Applications and Safety Sensors



Emergency Stop



Position switch

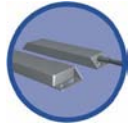

Electro-magnetic switch

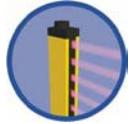

Light Curtain



Testable light barrier

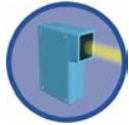

Muting sensor



Key lock switch



Enabling button



Two-hand control

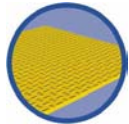

Safety mat



Laser scanner



Reset

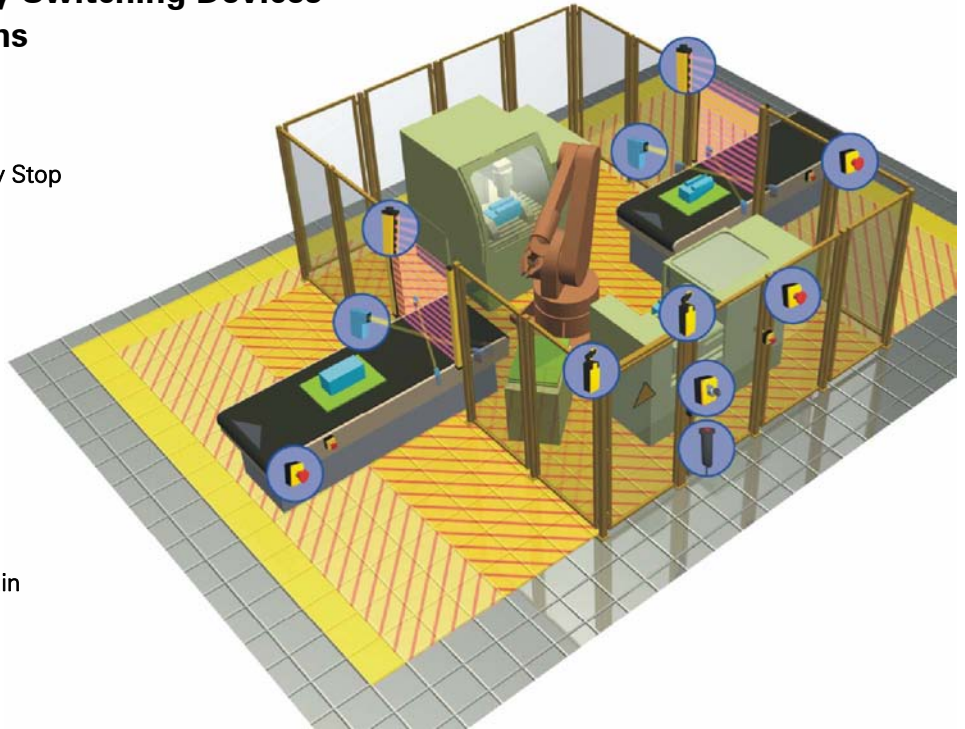

Wieland Electric offers safety switching devices for all standard industrial applications. They combine outstanding performance features, economic installation/removal and a high degree of environmental compatibility in the least amount of space. The devices are characterized by their multifunctional use and their ability for monitoring various types of sensors.

The Wieland Electric master base module of the *samos* system is the first multifunction safety switching device in the world in a 22.5 mm housing. This state-of-the-art technology offering a maximum in safety is currently being developed by Schleicher Electronic, which has more than 15 years of experience in this field. Of course, we adhere to the latest standards (e.g. IEC 61508).

Most types are also available with pluggable connectors (screws or spring technology) for time-saving maintenance.

Functions

- Emergency stop, with or without cross monitoring
- Safety gate monitoring, also with coded magnetic switches
- Controlled stop with settable OFF-delay up to 5 minutes, with or without retriggering
- Light barrier monitoring with testable/self-testing sensors (ESPE type 2 and 4)
- Position monitoring with testable inductive sensors (PDF)
- Access delay
- Static valve monitoring
- 4-wire safety mat monitoring
- Two-hand applications to EN 574, type IIIA and IIIC
- Automatic or manual reset, start and restart inhibit

About this manual

What Does This Manual Describe?

This manual describes applications with safety functions for machines and systems. The entire safety process is covered in this manual, from the safety sensor to the safe evaluation device to the switch-off. The information for installing the safety circuits is clearly presented, as is a brief summary of the applications and safety-related classifications (categories).

All applications mentioned are implemented with Wieland Electric's safe evaluation devices. The table of contents provides the user with various options to search for the appropriate safety application. Information regarding standards as well as instructions for risk analysis round off the manual.

Who Is This Manual For?

This manual is aimed at technically qualified personnel such as mechanical and electrical engineers, safety reps, PLC programmers, enclosure makers, electrical fitters, machine and plant operators, setup staff, and service and maintenance personnel. The devices and safety system described here should only be installed by specialists. Furthermore, the corresponding regulations of the Association for Electrical, Electronic & Information Technologies (VDE) or of the respective country's particular standards must be taken into account.

Safety-related Information



The "Caution" symbol is used at various places in this manual. "Caution" indicates a potentially dangerous situation or state that could – if not avoided – lead to minor or medium injury. "Caution" is also used to warn against uncertain operation and potential misuse. "Caution" is also used to indicate situations where property damage could occur without causing personal injury.

Safety Rules

Please observe the following safety rules:

- Only trained professional electricians may install, startup, modify, and retrofit this equipment!
- Disconnect supply voltage to the equipment / system prior to starting any work! If installation or system errors occur, line voltage may be present at the control circuit in devices without DC isolation!
- Observe all electrical safety regulations issued by the appropriate technical authorities or the trade association.
- Opening the housing or any other manipulation will void the warranty.
- If the device has been subjected to improper or incorrect use it must no longer be used, and the guarantee loses its validity. Impermissible conditions include: strong mechanical stress, for example through a fall, or voltages, currents, temperatures or humidity outside of the specifications.
- Before starting up your machine/plant for the first time, please be sure to check all the safety functions according to valid regulations, and observe the specified test cycles for safety equipment.
- Take the following safety measures prior to installation, assembly, or disassembly:
 - Disconnect supply voltage to the equipment / system prior to starting any work!
 - Lockout/tag the equipment/system to prevent accidental activation!
 - Confirm that no voltage is present!
 - Ground the phases and short to ground!
 - Protect against adjacent live components using guards and barriers!

Protection Types



Protection type according to EN 60529.
Limited contact protection!
Housing/terminals: IP 40 / IP 20.
Finger-proof (DIN EN 50274).

Proper Use

The safety applications described in this manual serve to protect people, the environment, the machine and the material according to the valid EU occupational health and safety directive 89/391/EEC, the machinery directive 98/37/EC, the use of work equipment directive 89/655/EEC as well as the statutory regulations and standards applicable in other countries (e.g. USA with OSHA 29 CFR 1910.xxx safety standards, OSHA 3067 concepts and technologies for machine safety and NPFA 70, NFPA 79, ANSI B11 product liability).

If the safety switching devices are properly maintained and used for their intended purpose they will not normally cause damage to property or present health hazards. However, improper configuration, installation, maintenance or operation of the system or machine, ignoring the instructions in this manual, or intervention by insufficiently qualified personnel may result in connected actuators (such as motors, hydraulic units, etc.) becoming a source of danger.

Wieland Electric safety switching devices are state-of-the-art products and are manufactured to recognized safety requirements. All the same, their use can cause danger to the health and safety of operators and others, or damage machines, systems or other property.

The safety switching devices must only be used in perfect technical condition for their intended purpose, with attention given to safety and danger, and observing the information and instructions given in this manual and the operating instructions supplied with the devices. Correct transport, storage, installation, operation and maintenance of the devices are all prerequisites for smooth and safe operation. Malfunctions, in particular those which may affect safety, must be immediately resolved.

In general, the technical restrictions of the safety switching devices must be observed. Information can be found at

www.wieland-electric.com → Info service
→ Download Center

Symbol Key



The arrow denotes an **actuated contact**.



The encircled arrow denotes a **positively opening contact**.

General Installation Requirements



- The devices must be installed in an enclosure with at least IP54 protection.
- The devices must be installed on a mounting rail (EN 50022-35).

samos Installation Requirements



- The mounting rail must be connected to protective earth (PE).
- The system and the system inputs must always be powered by a common power supply unit.
- The external power supply unit must comply with the regulations for safety and protection extra low voltage systems (SELV, PELV acc. to IEC 60536) and DIN EN 50178 (Electronic Equipment for Use in Power Installations).
- In general, a protective circuit (i.e. an RC combination) must be implemented when connecting inductive loads (i.e. valves or contactors).

Exclusion Of Liability

The application examples and circuitry suggestions have been developed to the state of the art and our best knowledge. Nonetheless, Wieland cannot accept liability for the correctness and completeness of the information. The information does not have the legal status of guarantees or guaranteed qualities.

Brand Names

All brands mentioned in this manual and, where applicable, third party registered trademarks are subject without restriction to the valid legal terms and property rights of the particular registered owner. The use of a brand name itself does not necessarily imply that it is not protected by a third party.

samos® is a registered brand name of Wieland Electric GmbH.
All rights reserved.

Overview According to Device Types

Cat-egory ¹⁾	Application	Safety sensors Features	Reset / start and restart inhibit	Stop category ²⁾	Applica-tion number	Page
samos						
3	Safety gate, emergency stop	2 safety zones, position switches, higher-priority emergency stop, OFF-delay	manual, monitor / automatic ⁶⁾	0/1 ³⁾	A 253	2 • 8
	Safety gate, emergency stop	2 safety zones, magnetic switches, higher-priority emergency stop	manual, monitor	0	A 258	2 • 9
	Light curtain, emergency stop	2 safety zones, emergency stop buttons, ESPE type 4 (SC)	manual, monitor	0	A 259	3 • 3
4	Safety gate	Position switches, key lock switch, OFF-delay	automatic	1	A 269	2 • 16
	Light curtain	ESPE type 4 (SC), muting sensors	manual, monitor	0	A 267	3 • 4
	Light curtain, safety gate	Emergency stop button, position switches, ESPE type 4 (SC), inductive sensor, OFF-delay	manual, monitor	1	A 268	2 • 15
SNA 4043K						
4	Emergency stop	Emergency stop button	manual, external	0	A 279	1 • 10
	Safety gate	Position switch	automatic	0	A 274	2 • 17
	Lift	Position switch	external	0	A 275	6 • 2
SNA 4063K						
4	Combustion plant	Temperature monitoring equipment contact expansion	external, monitor	0	A 280	7 • 2
	Emergency stop	Emergency stop button	manual, monitor	0	A 273	1 • 11
SNA 4064K						
2	Emergency stop	Emergency stop button	manual, monitor	0	A 276	1 • 2
3	Emergency stop	Emergency stop button	manual, monitor	0	A 277	1 • 1
4	Light curtain	ESPE type 4 (SC)	manual, monitor	0	A 278	3 • 5
SNE 4003K						
4	Light curtain	ESPE type 4 (SC)	external	0	A 281	3 • 6
SNE 4004K						
4	Emergency stop	Emergency stop button, contact expansion	manual, monitor	0	A 157	1 • 13
SNE 4004KV						
2	Emergency stop	Emergency stop button, contact expansion, OFF-delay	manual, monitor	1	A 158	1 • 5
SNE 4008S						
4	Emergency stop	Emergency stop button, contact expansion	manual, monitor	0	A 235	1 • 15

¹⁾ acc. to EN 954-1 ²⁾ acc. to EN 60204-1 ³⁾ instantaneous/delayed enables ⁴⁾ not applicable

Overview According to Device Types

Cat-egory ¹⁾	Application	Safety sensors Features	Reset / start and restart inhibit	Stop category ²⁾	Applica-tion number	Page
SNL 4062K						
4	Light curtain, emergency stop	ESPE type 2 (SC), emergency stop button	manual	0	A 241	3 • 2
SNO 2004K						
2	Emergency stop	Emergency stop button	manual	0	A 282	1 • 3
	Safety gate	Position switch	automatic	0	A 283	2 • 2
SNO 4003K						
2	Emergency stop	Emergency stop button, contact expansion with OFF-delay	manual, monitor	1	A 158	1 • 5
	Safety gate	Position switch	automatic	0	A 152	2 • 3
	Emergency stop	Emergency stop button	manual, monitor	0	A 151	1 • 4
SNO 4062K / SNO 4062KM						
2	Emergency stop	Emergency stop button	manual, monitor	0	A 153	1 • 6
	Emergency stop	Cable-operated emergency switch	manual, monitor	0	A 218	1 • 7
	Safety gate	Position switch	automatic	0	A 219	2 • 4
	Safety gate	Electronic position switch	manual, monitor	0	A 242	2 • 5
	Safety mat	Safety mat (NC contacts)	manual, monitor	0	A 217	5 • 2
3	Safety gate	3-wire proximity sensors (SC)	automatic	0	A 165	2 • 10
	Safety gate	Electronic position switch	manual, monitor	0	A 230	2 • 11
	Safety mat	Safety mat (NO contacts)	manual, monitor	0	A 156	5 • 3
4	Emergency stop	Emergency stop button	manual, monitor	0	A 154	1 • 12
	Emergency stop	Cable-operated emergency switch	manual, monitor	0	A 216	1 • 14
	Emergency stop	Emergency stop button, contact expansion	manual, monitor	0	A 157	1 • 13
	Emergency stop	Emergency stop button, contact expansion	manual, monitor	0	A 235	1 • 15
	Safety gate	Position switches, synchrocheck	automatic	0	A 155	2 • 18
	Safety gate	Electronic position switches	automatic	0	A 243	2 • 19
	Light curtain	ESPE type 4 (SC)	manual, monitor	0	A 229	3 • 7
SNO 4063K						
4	Emergency stop	Emergency stop button	manual, monitor	0	A 225	1 • 16
	Safety gate	Position switches, synchrocheck	automatic	0	A 226	2 • 20
	Safety gate	Electronic position switches	automatic	0	A 244	2 • 21
SNO 5002K						
2	Emergency stop	Emergency stop button	manual, monitor	0	A 284	1 • 8
	Safety gate	Position switch	automatic	0	A 285	2 • 7

¹⁾ acc. to EN 954-1 ²⁾ acc. to EN 60204-1 ³⁾ instantaneous/delayed enables ⁴⁾ not applicable

Overview According to Device Types

Cat-egory ¹⁾	Application	Safety sensors Features	Reset / start and restart inhibit	Stop category ²⁾	Applica-tion number	Page
SNT 4M63K						
3	Safety gate	Position switch with tumbler	automatic	0	A 232	2 • 12
4	Emergency stop	Emergency stop button	manual, monitor	0	A 228	1 • 17
	Safety gate	Position switches, synchrocheck	automatic	0	A 221	2 • 22
	Safety gate	Position switches, synchrocheck	automatic	0	A 222	2 • 23
	Safety gate	Magnetic switch	automatic	0	A 233	2 • 24
	Safety gate	Magnetic switch	manual, monitor	0	A 234	2 • 25
SNV 4063KL						
2	Safety gate	Position switch, OFF-delay	automatic	1	A 220	2 • 6
3	Safety gate	Position switch with tumbler, OFF-delay	automatic	1	A 181	2 • 13
4/3 ³⁾	Safety gate	Position switches, OFF-delay, synchrocheck	automatic	1	A 174	2 • 26
	Emergency stop	Emergency stop button, OFF-delay	manual, monitor	1	A 173	1 • 18
SNV 4063KP						
3	Safety gate	Position switch with tumbler, ON-delay	manual, monitor	1	A 176	2 • 14
SNZ 4052K						
4	Two-hand control	Two-hand momentary contact switches	automatic	0	A 149	4 • 2

¹⁾ acc. to EN 954-1 ²⁾ acc. to EN 60204-1 ³⁾ instantaneous/delayed enables ⁴⁾ not applicable



Overview According to Application Number

Application number	Device	Application • Safety sensors/Features • Category ¹⁾	Page
A 149	SNZ 4052K	Two-hand control • Two-hand momentary contact switches • Cat. 4	4 • 2
A 151	SNO 4003K	Emergency stop • Emergency stop button, contact expansion, OFF-delay • Cat. 2	1 • 4
A 152	SNO 4003K	Safety gate • Position switch • Cat. 2	2 • 3
A 153	SNO 4062K	Emergency stop • Emergency stop button • Cat. 2	1 • 6
A 154	SNO 4062K	Emergency stop • Emergency stop button • Cat. 4	1 • 12
A 155	SNO 4062K	Safety gate • Position switches, synchrocheck • Cat. 4	2 • 18
A 156	SNO 4062KM	Safety mat • Safety mat (NO contacts) • Cat. 3	5 • 3
A 157	SNO 4062K + SNE 4004K	Emergency stop • Emergency stop button, contact expansion • Cat. 4	1 • 13
A 158	SNO 4003K + SNE 4004KV	Emergency stop • Emergency stop button • Cat. 3	1 • 5
A 165	SNO 4062K	Safety gate • 3-wire proximity sensors (SC) • Cat. 4	2 • 10
A 173	SNV 4063KL	Emergency stop • Emergency stop button, OFF-delay • Cat. 4/3 ²⁾	1 • 18
A 174	SNV 4063KL	Safety gate • Position switches, OFF-delay, synchrocheck • Cat. 4/3 ²⁾	2 • 26
A 176	SNV 4063KP	Safety gate • Position switch with tumbler, ON-delay • Cat. 3	2 • 14
A 181	SNV 4063KL	Safety gate • Position switch with tumbler, OFF-delay • Cat. 3	2 • 13
A 216	SNO 4062K	Emergency stop • Cable-operated emergency switch • Cat. 4	1 • 14
A 217	SNO 4062KM	Safety mat • Safety mat (NC contacts) • Cat. 2	5 • 2
A 218	SNO 4062K	Emergency stop • Cable-operated emergency switch • Cat. 2	1 • 7
A 219	SNO 4062K	Safety gate • Position switch • Cat. 2	2 • 4
A 220	SNV 4063KL	Safety gate • Position switch, OFF-delay • Cat. 2	2 • 6
A 221	SNT 4M63K	Safety gate • Position switches, synchrocheck • Cat. 4	2 • 22
A 222	SNT 4M63K	Safety gate • Position switches, synchrocheck • Cat. 4	2 • 23
A 225	SNO 4063K	Emergency stop • Emergency stop button • Cat. 4	1 • 16
A 226	SNO 4063K	Safety gate • Position switches, synchrocheck • Cat. 4	2 • 20
A 228	SNT 4M63K	Emergency stop • Emergency stop button • Cat. 4	1 • 17
A 229	SNO 4062K	Light curtain • ESPE type 4 (SC) • Cat. 4	3 • 7
A 230	SNO 4062K	Safety gate • Electronic position switch • Cat. 3	2 • 11
A 232	SNT 4M63K	Safety gate • Position switch with tumbler • Cat. 3	2 • 12
A 233	SNT 4M63K	Safety gate • Magnetic switch • Cat. 4	2 • 24
A 234	SNT 4M63K	Safety gate • Magnetic switch • Cat. 4	2 • 25
A 235	SNO 4062K + SNE 4008S	Emergency stop • Emergency stop button, contact expansion • Cat. 4	1 • 15
A 241	SNL 4062K	Light curtain • ESPE type 2 (SC), emergency stop button • Cat. 2	3 • 2
A 242	SNO 4062K	Safety gate • Electronic position switch • Cat. 2	2 • 5
A 243	SNO 4062K	Safety gate • Electronic position switches • Cat. 4	2 • 19
A 244	SNO 4063K	Safety gate • Electronic position switches • Cat. 4	2 • 21
A 253	samos	Safety gate, emergency stop • 2 safety zones, position switches, higher-priority emergency stop, OFF-delay • Cat. 3	2 • 8
A 258	samos	Safety gate, emergency stop • 2 safety zones, magnetic switches, higher-priority emergency stop • Cat. 3	2 • 9
A 259	samos	Light curtain, emergency stop • 2 safety zones, emergency stop buttons, ESPE type 4 (SC) • Cat. 3	3 • 3
A 267	samos	Light curtain • ESPE type 4 (SC), muting sensors • Cat. 4	3 • 4
A 268	samos	Light curtain, safety gate • Emergency stop button, position switches, ESPE type 4 (SC), inductive sensor, OFF-delay • Cat. 4	2 • 15
A 269	samos	Safety gate • Position switches, key lock switch, OFF-delay • Cat. 4	2 • 16

¹⁾ acc. to EN 954-1 ²⁾ instantaneous/delayed enables

Overview According to Application Number

Application number	Device	Application • Safety sensors/Features • Category ¹⁾	Page
A 273	SNA 4063K	Emergency stop • Emergency stop button • Cat. 4	1 • 11
A 274	SNA 4043K	Safety gate • Position switches • Cat. 4	2 • 17
A 275	SNA 4043K	Lift • Position switches	6 • 2
A 276	SNA 4064K	Emergency stop • Emergency stop button • Cat. 2	1 • 2
A 277	SNA 4064K	Emergency stop • Emergency stop button • Cat. 3	1 • 9
A 278	SNA 4064K	Light curtain • ESPE type 4 (SC) • Cat. 4	3 • 5
A 279	SNA 4043K	Emergency stop • Emergency stop button • Cat. 4	1 • 10
A 280	SNA 4063K	Combustion plant • Temperature monitoring equipment contact expansion	7 • 2
A 281	SNE 4003K	Light curtain • ESPE type 4 (SC) • Cat. 4	3 • 6
A 282	SNO 2004K	Emergency stop • Emergency stop button • Cat. 2	1 • 3
A 283	SNO 2004K	Safety gate • Position switch • Cat. 2	2 • 2
A 284	SNO 5002K	Emergency stop • Emergency stop button • Cat. 2	1 • 8
A 285	SNO 5002K	Safety gate • Position switch • Cat. 2	2 • 7

¹⁾ acc. to EN 954-1 ²⁾ instantaneous/delayed enables

Notes:

Every application is assigned a unique, company-wide ID number that is used consistently throughout all Wieland Electric documentation. The application number facilitates finding the desired applications.

1 Emergency Stop

Cat-egory ¹⁾	Device	Safety sensors Features	Reset / start and restart inhibit	Stop category ²⁾	Applica-tion number	Page
2	SNA 4064K	Emergency stop button	manual, monitor	0	A 276	1 • 2
	SNL 4062K	ESPE type 2 (SC), emergency stop button	manual	0	A 241	3 • 2
	SNO 2004K	Emergency stop button	manual	0	A 282	1 • 3
	SNO 4003K	Emergency stop button	manual, monitor	0	A 151	1 • 4
	SNO 4003K + SNE4004KV	Emergency stop button, contact expansion, OFF-delay	manual, monitor	1	A 158	1 • 5
	SNO 4062K	Emergency stop button	manual, monitor	0	A 153	1 • 6
	SNO 4062K	Cable-operated emergency switch	manual, monitor	0	A 218	1 • 7
	SNO 5002K	Emergency stop button	manual, monitor	0	A 284	1 • 1
3	<i>samos</i>	2 safety zones, position switches, higher-priority emergency stop, OFF-delay	manual, monitor / automatic	0/1 ³⁾	A 253	2 • 8
	<i>samos</i>	2 safety zones, magnetic switches, higher-priority emergency stop	manual, monitor	0	A 258	2 • 9
	<i>samos</i>	2 safety zones, emergency stop buttons, ESPE type 4 (SC)	manual, monitor	0	A 259	3 • 3
	SNA 4064K	Emergency stop button	manual, monitor	0	A 277	1 • 9
4	SNA 4043K	Emergency stop button	manual, external	0	A 279	1 • 10
	SNA 4063K	Emergency stop button	manual, monitor	0	A 273	1 • 11
	SNL 4062K	ESPE type 2 (SC), emergency stop button	manual	0	A 241	3 • 2
	SNO 4062K	Emergency stop button	manual, monitor	0	A 154	1 • 12
	SNO 4062K + SNE 4004K	Emergency stop button, contact expansion	manual, monitor	0	A 157	1 • 13
	SNO 4062K	Cable-operated emergency switch	manual, monitor	0	A 216	1 • 14
	SNO 4062K + SNE 4008S	Emergency stop button, contact expansion	manual, monitor	0	A 235	
	SNO 4063K	Emergency stop button	manual, monitor	0	A 225	1 • 16
	SNT 4M63K	Emergency stop button	manual, monitor	0	A 228	1 • 17
4/3 ³⁾	SNV 4063KL	Emergency stop button, OFF-delay	manual, monitor	1	A 173	1 • 18

¹⁾ acc. to EN 954-1 ²⁾ acc. to EN 60204-1 ³⁾ instantaneous/delayed enables

Single-Channel Emergency Stop Monitor

Type of Device	SNA 4064K (all voltage versions)	
Category	Application (acc. to EN 954-1)	2
	Stop category (acc. to EN 60204-1)	0
Application Features	<ul style="list-style-type: none"> • 1-channel monitor • ground-fault detection • manual, monitored reset • monitoring of external contactors (EDM) 	
Safety Sensors	Emergency stop button	
Remarks/Notes	If the Safety devices are in the same control cabinet or protective wiring is used then 1-channel control of the contactors/expansion devices is acceptable.	

1

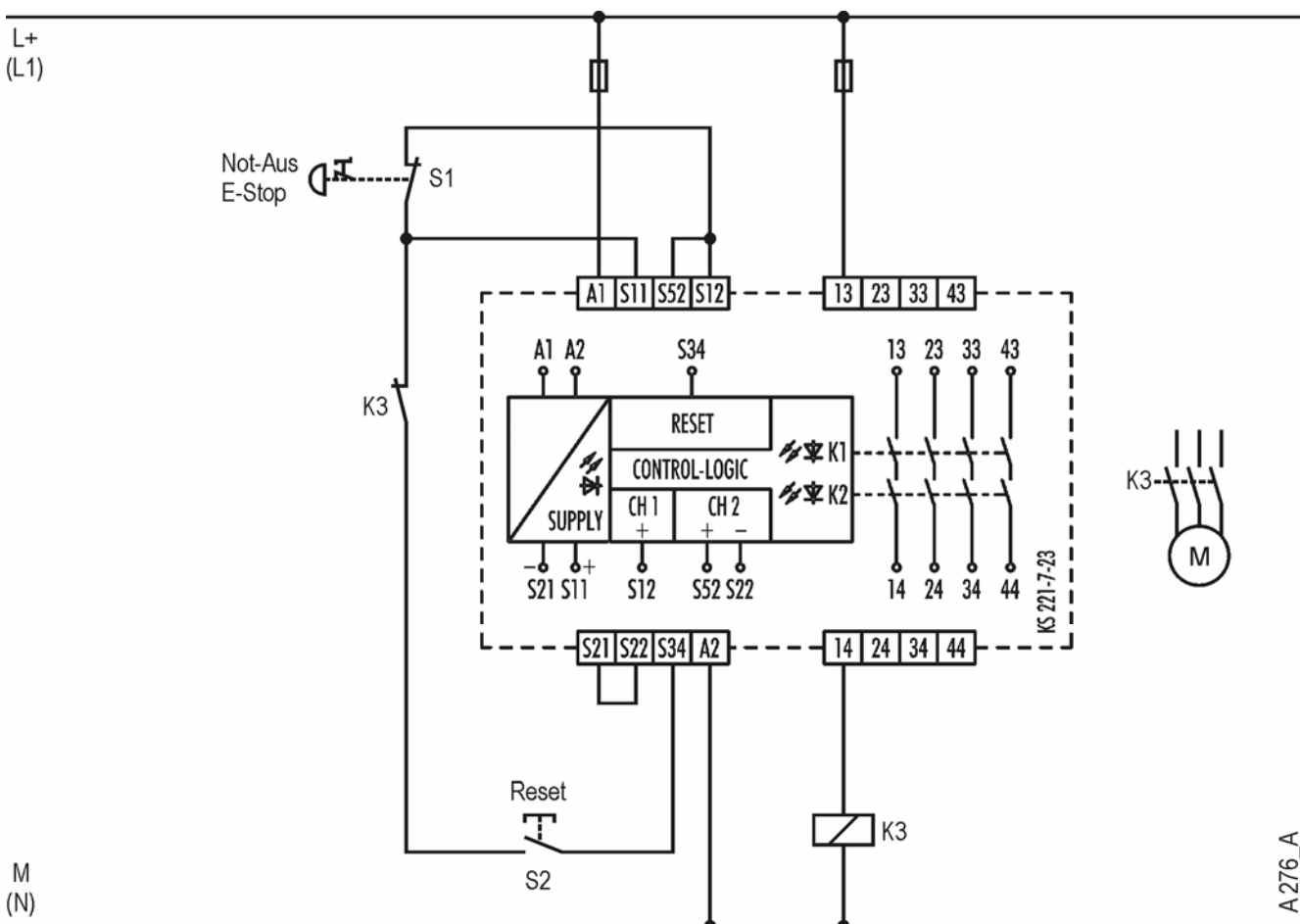

Single-channel emergency stop monitoring with manual, monitored reset.

The safety switching device and the contactor K3 are switched on when the emergency stop button is unlocked, the feedback circuit (NC contact K3) is closed and the reset button is actuated after the standby time has elapsed. When the emergency stop button is actuated, the safety switching device and the contactor K3 switch off.

Caution: The protective devices must be tested regularly via machine control or manually (organizational measure). Category 2 according to EN 954-1 can only be attained when an automatic warning is issued on actuator failure or the machine control initiates a safe status. Otherwise, a second switch-off method is necessary.

Single-Channel Emergency Stop Monitor

Type of Device	SNO 2004K	
Category	Application (acc. to EN 954-1)	2
	Stop category (acc. to EN 60204-1)	0
Application Features	<ul style="list-style-type: none"> • 1-channel monitor • ground-fault detection • manual reset • monitoring of external contactors (EDM) 	
Safety Sensors	Emergency stop button	
Remarks/Notes	If the Safety devices are in the same control cabinet or protective wiring is used then 1-channel control of the contactors/expansion devices is acceptable.	

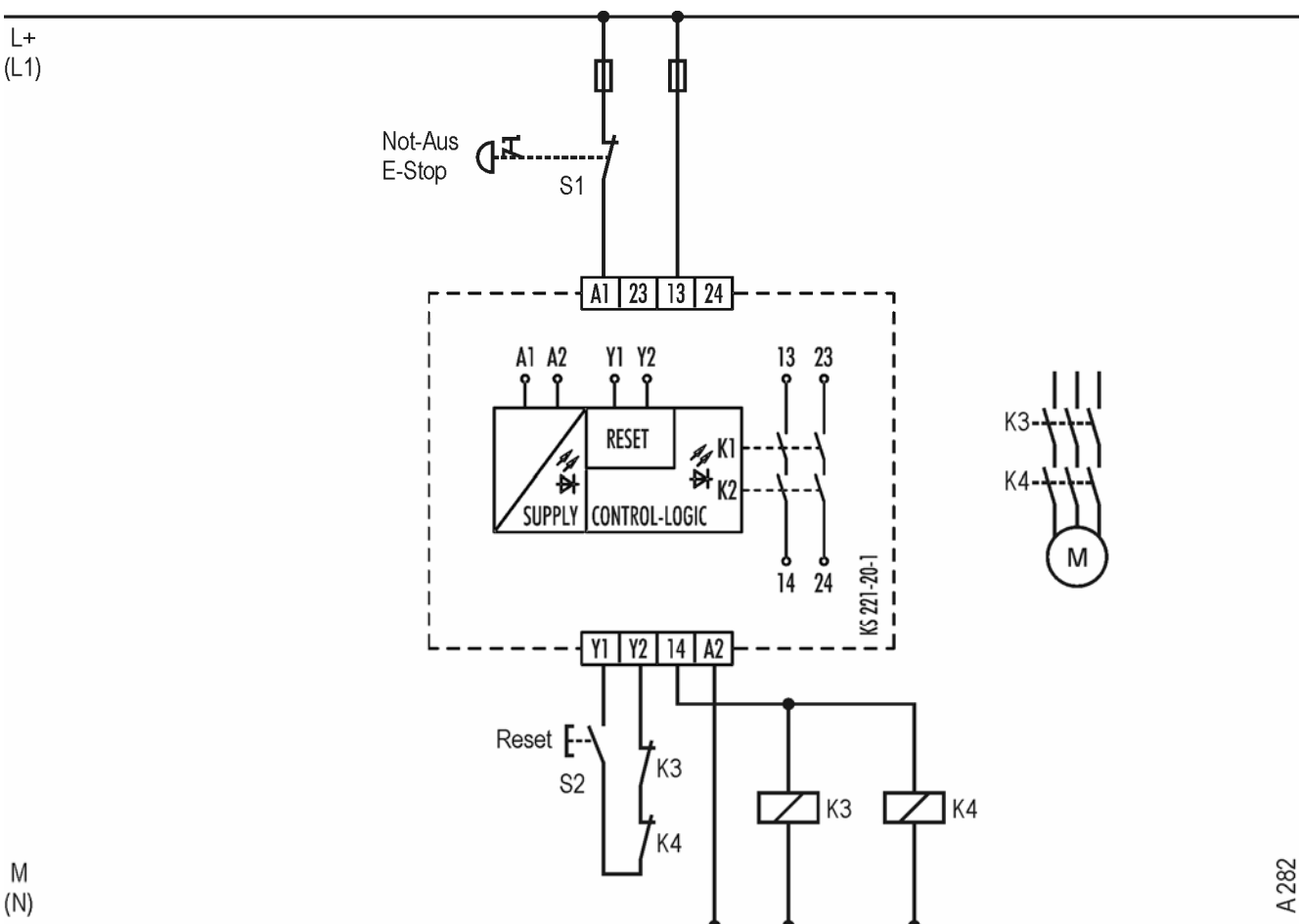

Single-channel emergency stop monitoring with manual reset.

The safety switching device and the contactors K3, K4 are switched on when the emergency stop button is unlocked, the feedback circuit (NC contacts K3, K4) is closed and the reset button is actuated. When the emergency stop button is actuated, the safety switching device and the contactors K3, K4 switch off.

Caution: The protective devices must be tested regularly via machine control or manually (organizational measure). Category 2 according to EN 954-1 can only be attained when an automatic warning is issued on actuator failure or the machine control initiates a safe status. Otherwise, a second switch-off method is necessary.

Caution: Caused by the fault "S2 does not open" the manual reset changes to automatic reset. It is recommended to use application A153 if the fault cannot be excluded.

Single-Channel Emergency Stop Monitor with Contact Expansion and OFF-Delay

Type of Device	SNO 4003K / SNE 4004KV	
Category	Application (acc. to EN 954-1)	2
	Stop category (acc. to EN 60204-1)	1
Application Features	<ul style="list-style-type: none"> • 1-channel monitor • ground-fault detection • manual, monitored reset • OFF-delay • monitoring of the expansion device SNE and external contactors 	
Safety Sensors	Emergency stop button	
Remarks/Notes	The single-channel wiring between the base device and the expansion device complies with Category 4 according to EN 954-1 as long as installation takes place within a control cabinet and is short-circuit protected.	

1

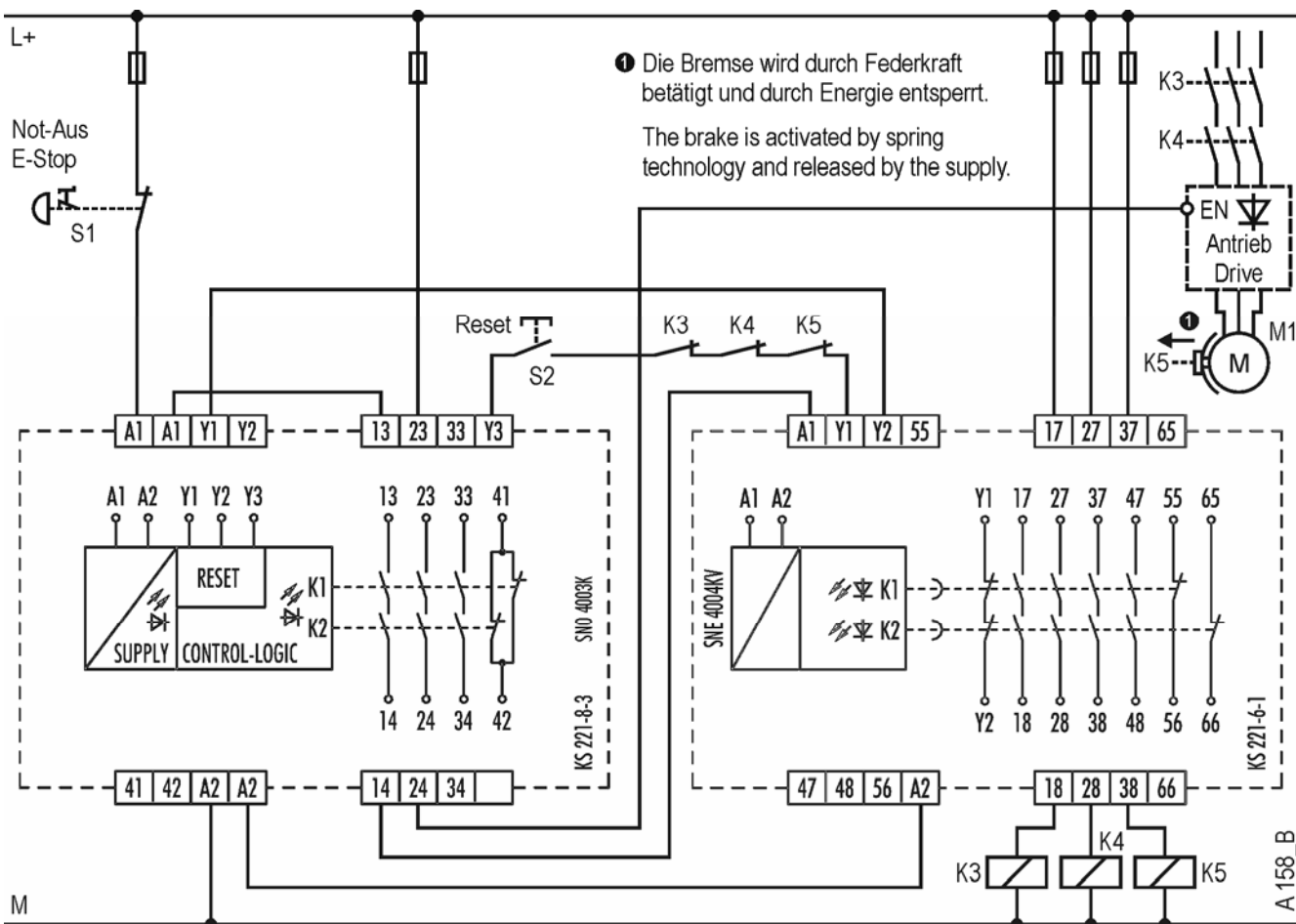

Single-channel emergency stop monitoring with manual, monitored reset.

The safety switching device and the contactors K3, K4 are switched on and the brake is released by K5 when the emergency stop button is unlocked, the feedback circuit (NC contacts K3, K4, K5) is closed and the reset button is actuated after the standby time has elapsed. When the emergency stop button is actuated, the drive control enable input is switched off and the drive is powered

down. After the OFF-delay has elapsed, the contactors K3, K4 are switched off and the brake is applied by K5.

Caution: The protective devices must be tested regularly via machine control or manually (organizational measure). Category 2 according to EN 954-1 can only be attained when an automatic warning is issued on actuator failure or the machine control initiates a safe status. Otherwise, a second switch-off method is necessary.

Single-Channel Emergency Stop Monitor

Type of Device	SNO 4062K	
Category	Application (acc. to EN 954-1)	2
	Stop category (acc. to EN 60204-1)	0
Application Features	<ul style="list-style-type: none"> • 1-channel monitor • manual, monitored reset • monitoring of external contactors (EDM) 	
Safety Sensors	Emergency stop button	
Remarks/Notes	If the Safety devices are in the same control cabinet or protective wiring is used then 1-channel control of the contactors/expansion devices is acceptable.	

1

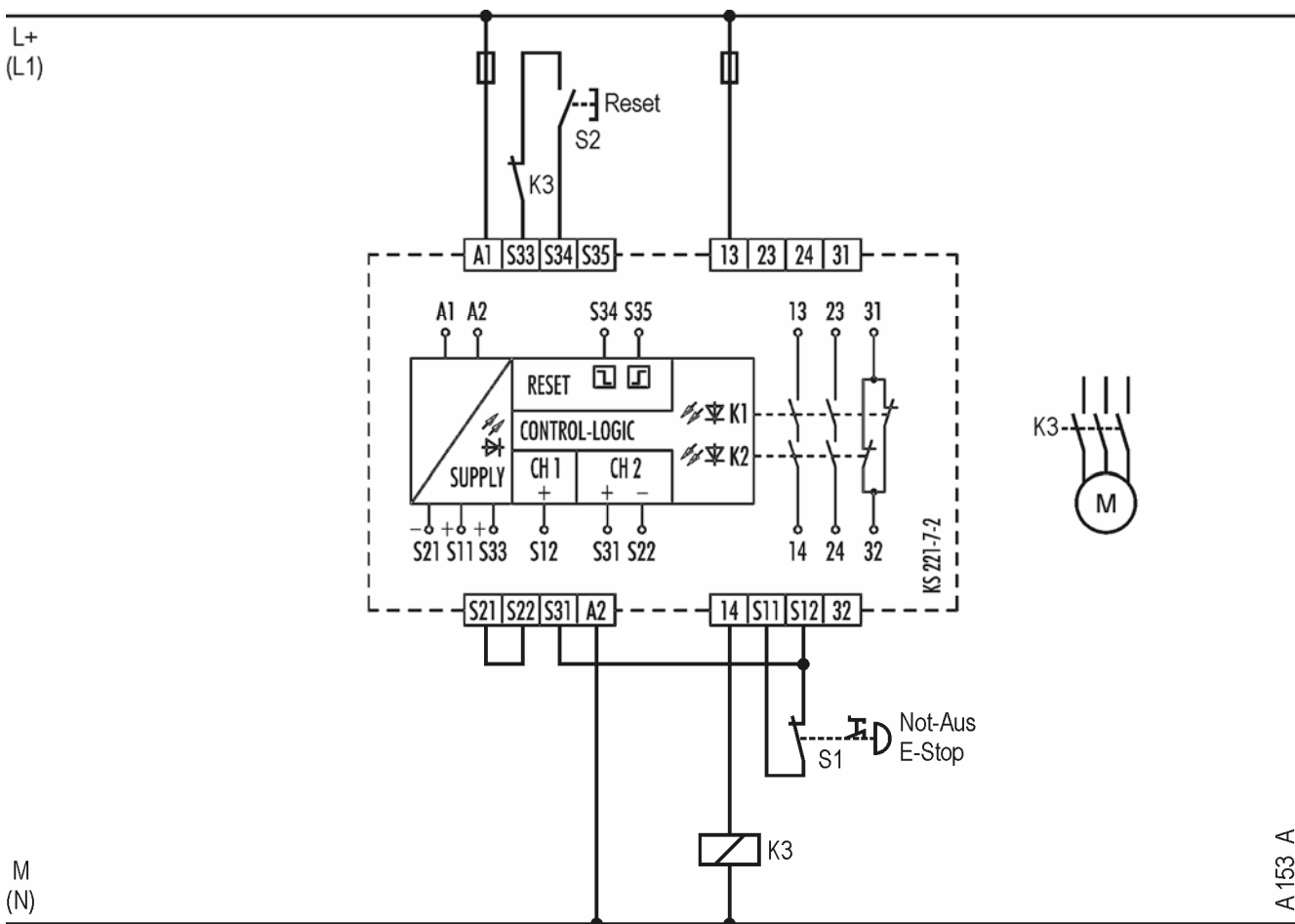

Single-channel emergency stop monitoring with manual, monitored reset.

The safety switching device and the contactor K3 are switched on when the emergency stop button is unlocked, the feedback circuit (NC contact K3) is closed and the reset button is actuated and released again. When the emergency stop button is actuated, the safety switching device and the contactor K3 switch off.

Caution: The protective devices must be tested regularly via machine control or manually (organizational measure). Category 2 according to EN 954-1 can only be attained when an automatic warning is issued on actuator failure or the machine control initiates a safe status. Otherwise, a second switch-off method is necessary.

Single-Channel Emergency Stop Monitor with Cable-Operated Emergency Switch

Type of Device	SNO 4062K	
Category	Application (acc. to EN 954-1)	2
	Stop category (acc. to EN 60204-1)	0
Application Features	<ul style="list-style-type: none"> • 1-channel monitor • manual, monitored reset • monitoring of external contactors (EDM) 	
Safety Sensors	Cable-operated emergency switch	
Remarks/Notes	If the Safety devices are in the same control cabinet or protective wiring is used then 1-channel control of the contactors/expansion devices is acceptable.	

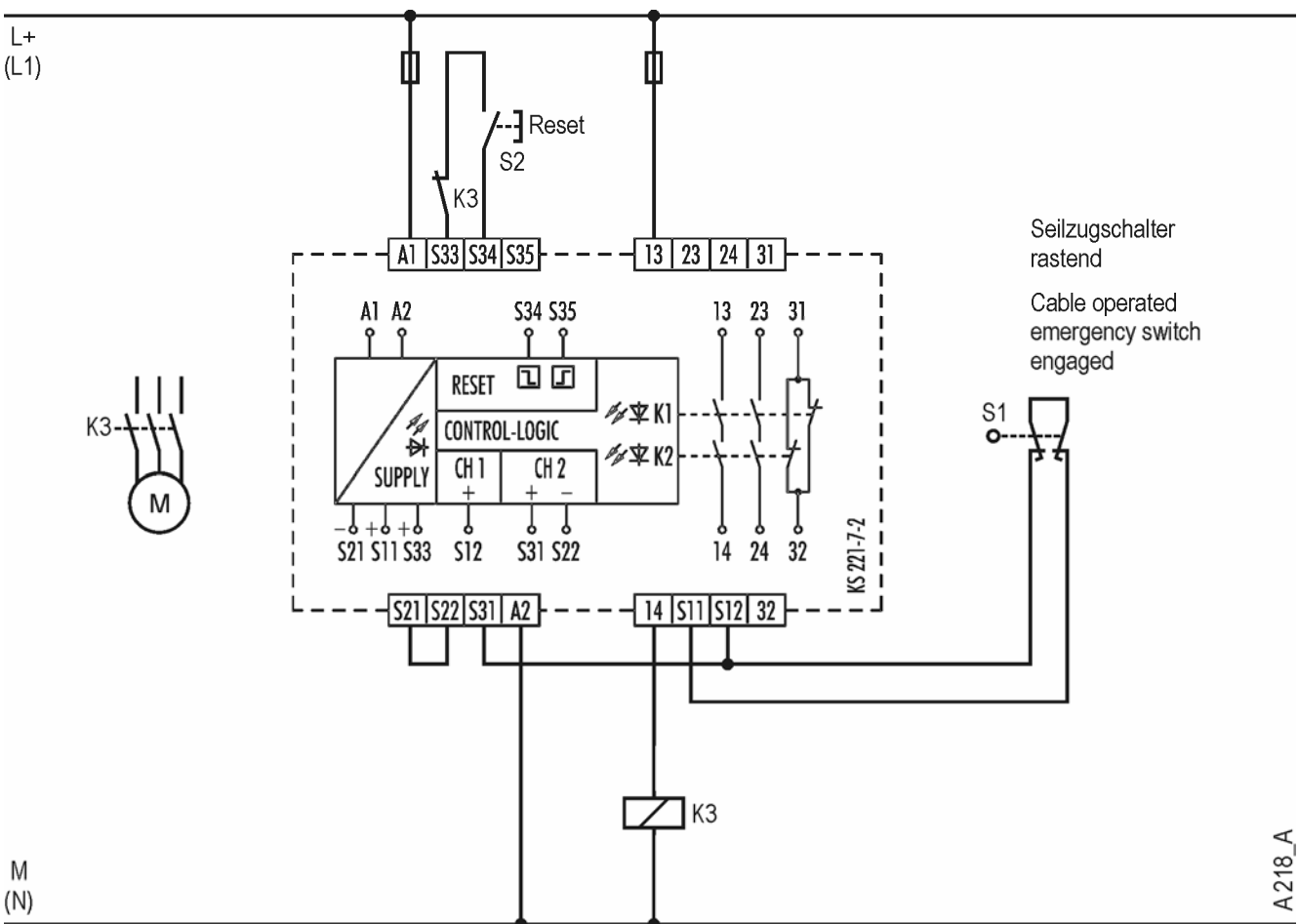

Single-channel emergency stop monitoring with cable-operated emergency switch and manual, monitored reset.

The safety switching device and the contactor K3 are switched on when the cable-operated emergency switch and the feedback circuit (NC contact K3) are closed and the reset button is actuated and released again. When the cable-operated emergency switch is actuated, the safety switching device and the contactor K3 switch off.

Caution: The protective devices must be tested regularly via machine control or manually (organizational measure). Category 2 according to EN 954-1 can only be attained when an automatic warning is issued on actuator failure or the machine control initiates a safe status. Otherwise, a second switch-off method is necessary.

Single-Channel Emergency Stop Monitor

Type of Device	SNO 5002K (DC 24 V)	
Category	Application (acc. to EN 954-1)	2
	Stop category (acc. to EN 60204-1)	0
Application Features	<ul style="list-style-type: none"> • 1-channel monitor • ground-fault detection • manual, monitored reset • monitoring of external contactors (EDM) 	
Safety Sensors	Emergency stop button	
Remarks/Notes	-	

1

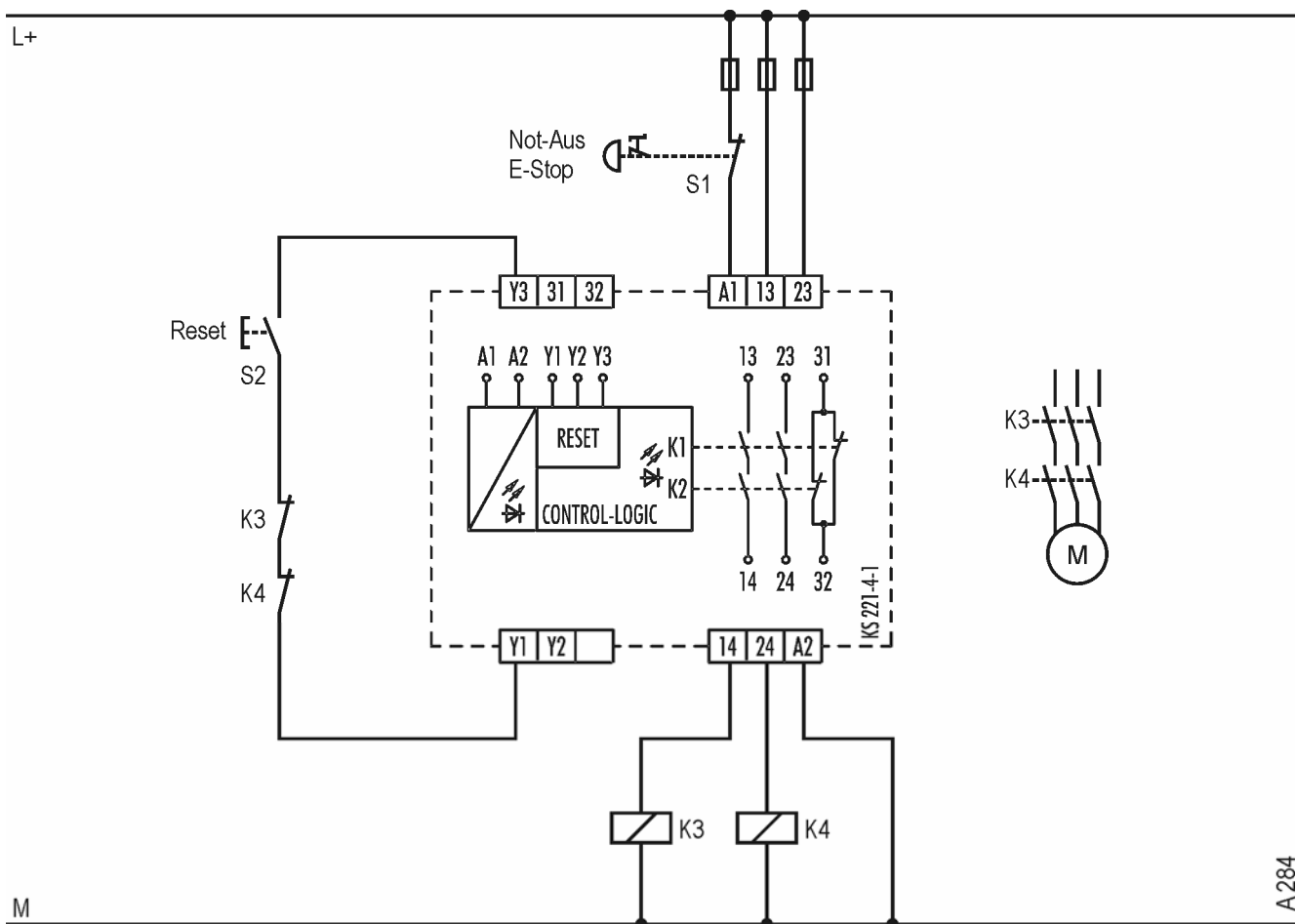

Single-channel emergency stop monitoring with manual reset.

The safety switching device and the contactors K3, K4 are switched on when the emergency stop button is unlocked, the feedback circuit (NC contacts K3, K4) is closed and the reset button is actuated after the standby time has elapsed. When the emergency stop button is actuated, the safety switching device and the contactors K3, K4 switch off.

Caution: The protective devices must be tested regularly via machine control or manually (organizational measure). Category 2 according to EN 954-1 can only be attained when an automatic warning is issued on actuator failure or the machine control initiates a safe status. Otherwise, a second switch-off method is necessary.

Two-Channel Emergency Stop Monitor

Type of Device	SNA 4064K (all voltage versions)	
Category	Application (acc. to EN 954-1)	3
	Stop category (acc. to EN 60204-1)	0
Application Features	<ul style="list-style-type: none"> • 2-channel monitor • ground-fault detection • manual, monitored reset • monitoring of external contactors (EDM) 	
Safety Sensors	Emergency stop button	
Remarks/Notes	If the Safety devices are in the same control cabinet or protective wiring is used then 1-channel control of the contactors/expansion devices is acceptable.	

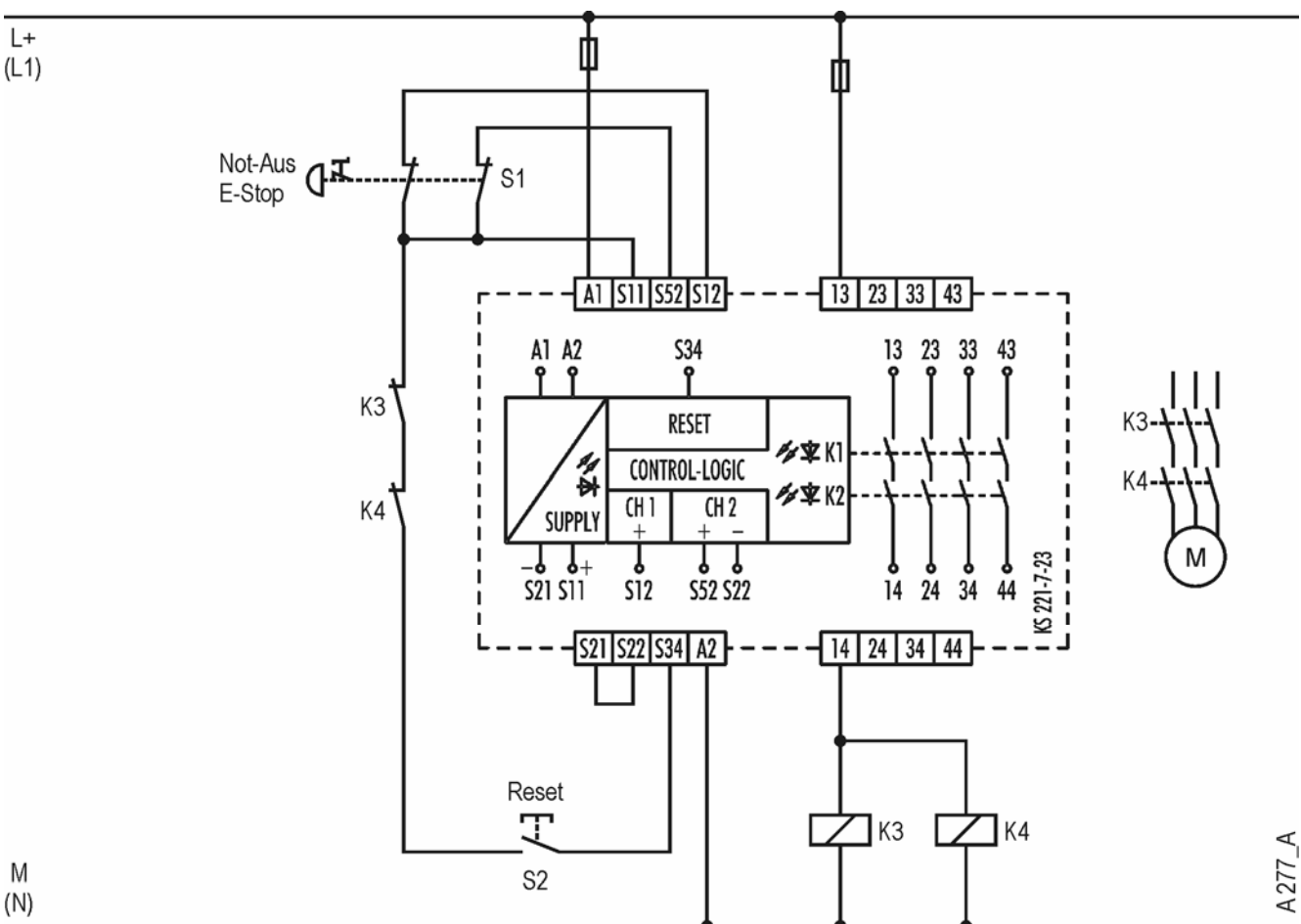

Two-channel emergency stop monitoring with manual, monitored reset.

The safety switching device and the contactors K3, K4 are switched on when the emergency stop button is unlocked, the feedback circuit (NC contacts K3, K4) is closed and the reset button is actuated after the standby time has elapsed. When the emergency stop button is actuated, the safety switching device and the contactors K3, K4 switch off.

A failure of one of the switching elements of the emergency stop button does not lead to a failure of the emergency stop device. The problem is detected during the next switching on process.

Two-Channel Emergency Stop Monitor

Type of Device	SNA 4043K (all voltage versions)	
Category	Application (acc. to EN 954-1)	4
	Stop category (acc. to EN 60204-1)	0
Application Features	<ul style="list-style-type: none"> • 2-channel monitor • cross monitoring • ground-fault detection • external reset • monitoring of external contactors (EDM) 	
Safety Sensors	Emergency stop button	
Remarks/Notes	The PLC prevents the machine/system from automatically resetting.	

1

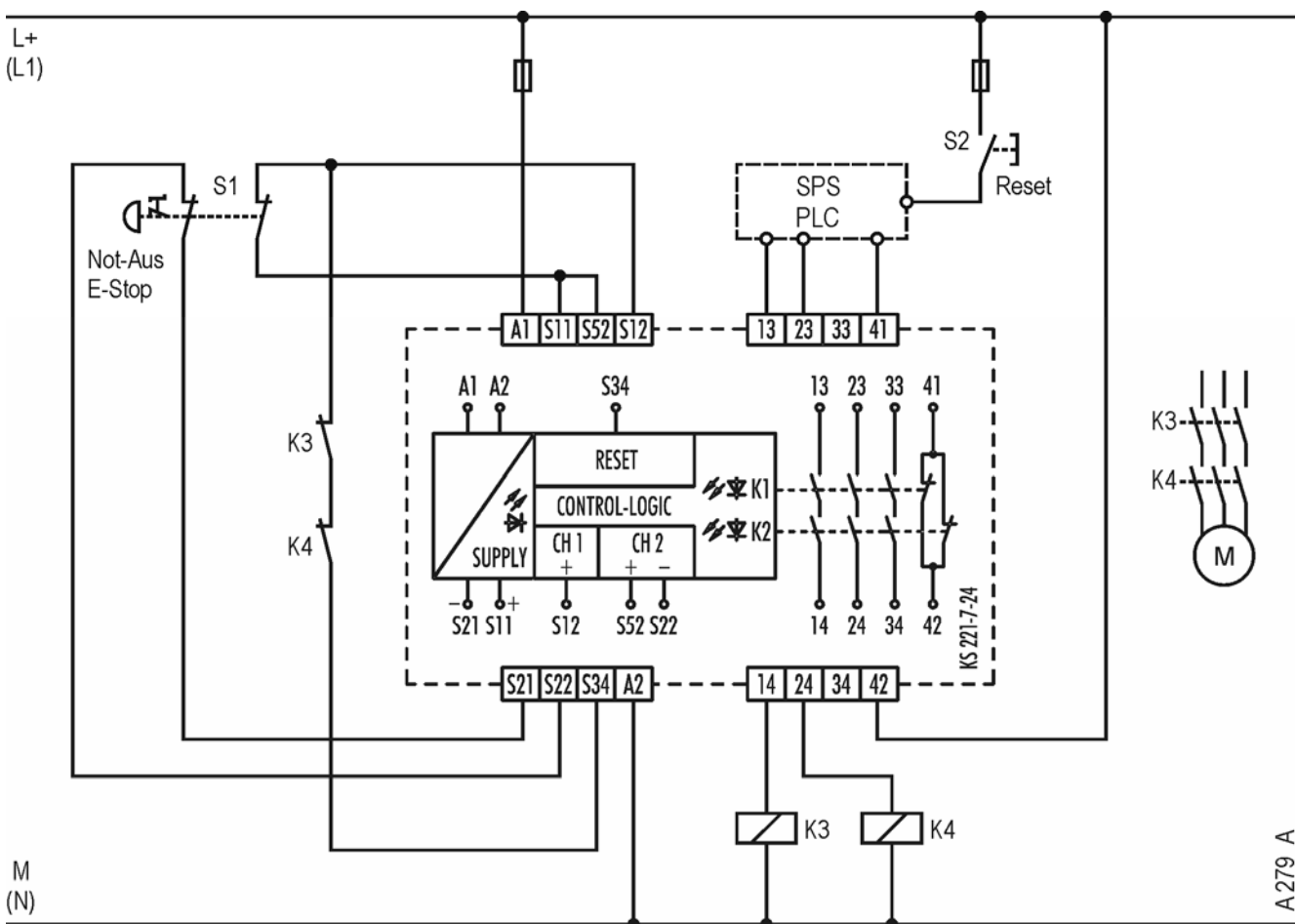

Two-channel emergency stop monitoring (cross monitoring) with manual, external reset.

The safety switching device is automatically switched on when the emergency stop button is unlocked and the feedback circuit (NC contacts K3, K4) is closed. The contactors K3, K4, however, are only switched on when the PLC receives a reset command and its outputs address the contactors. When the emergency stop button is actuated, the safety switching device and the contactors K3, K4 switch off.

A failure of one of the switching elements of the emergency stop button or a crossover in their supply lines does not lead to a failure of the emergency stop device. The problem is detected during the next switching on process.

Caution: You must avoid that a fault in the reset circuit with S2 changes the manual reset to automatic reset. This can be done by controlling the dynamic on actuating S2 at the PLC's reset input.

Two-Channel Emergency Stop Monitor

Type of Device	SNA 4063K (all voltage versions)	
Category	Application (acc. to EN 954-1)	4
	Stop category (acc. to EN 60204-1)	0
Application Features	<ul style="list-style-type: none"> • 2-channel monitor • cross monitoring • ground-fault detection • manual, monitored reset • monitoring of external contactors (EDM) 	
Safety Sensors	Emergency stop button	
Remarks/Notes	-	

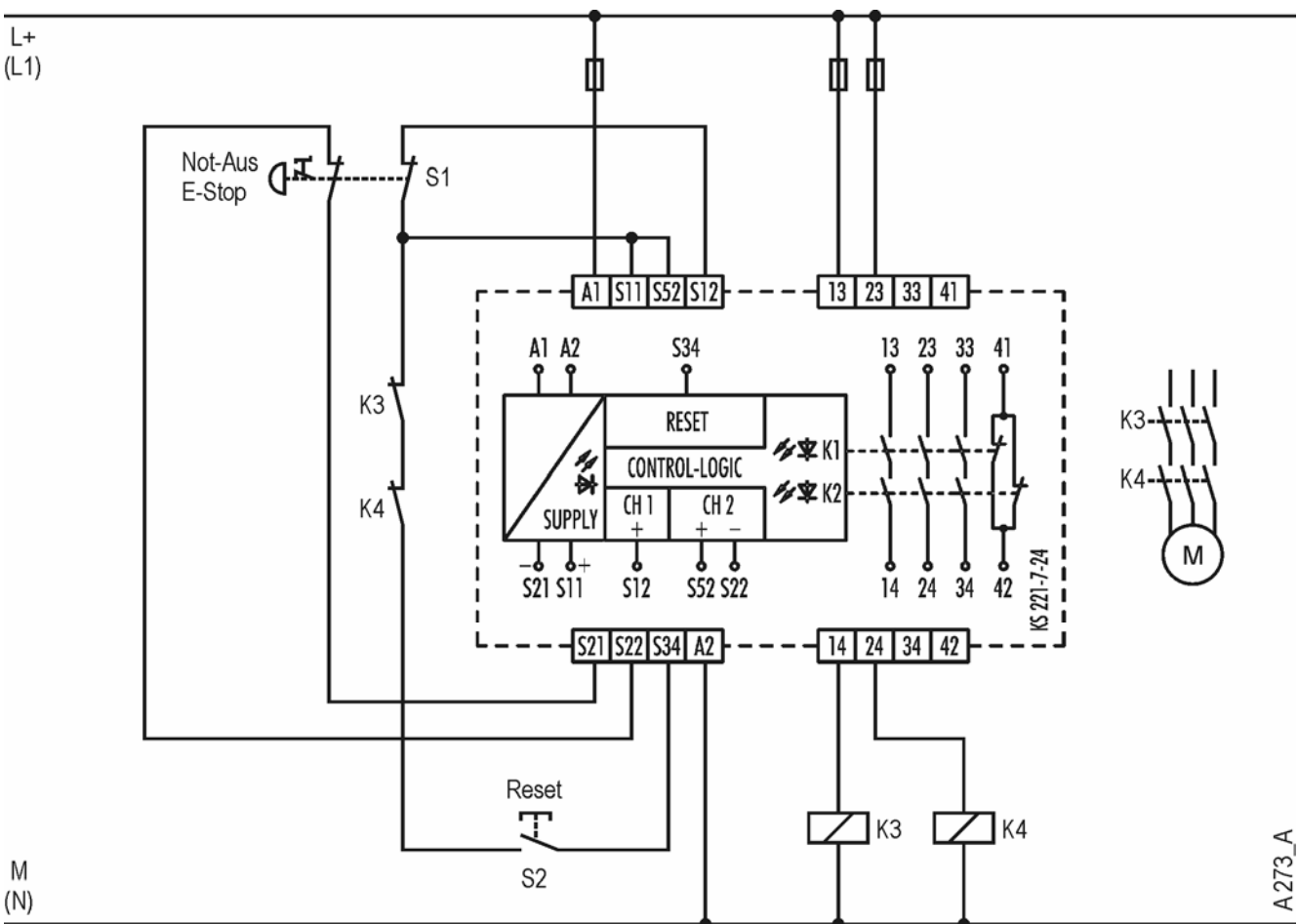

Two-channel emergency stop monitoring (cross monitoring) with manual, monitored reset.

The safety switching device and the contactors K3, K4 are switched on when the emergency stop button is unlocked, the feedback circuit (NC contacts K3, K4) is closed and the reset button is actuated after the standby time has elapsed. When the emergency stop button is actuated, the safety switching device and the contactors K3, K4 switch off.

A failure of one of the switching elements of the emergency stop button or a cross-circuit between its feed cables does not lead to a failure of the emergency stop device. The problem is detected during the next switching on process.

Two-Channel Emergency Stop Monitor

Type of Device	SNO 4062K	
Category	Application (acc. to EN 954-1)	4
	Stop category (acc. to EN 60204-1)	0
Application Features	<ul style="list-style-type: none"> • 2-channel monitor • cross monitoring • manual, monitored reset • monitoring of external contactors (EDM) 	
Safety Sensors	Emergency stop button	
Remarks/Notes	-	

1

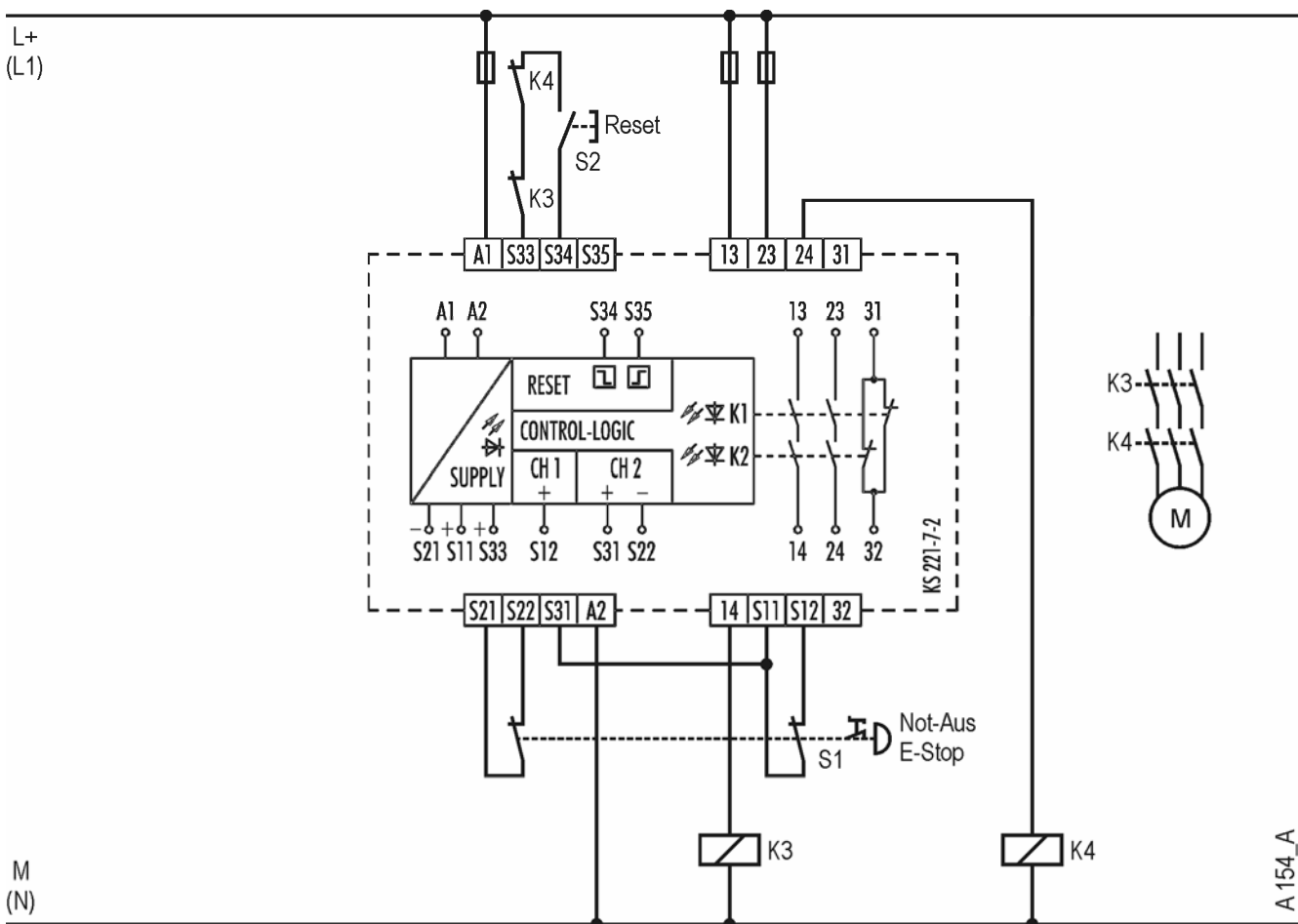

Two-channel emergency stop monitoring (cross monitoring) with manual, monitored reset.

The safety switching device and the contactors K3, K4 are switched on when the emergency stop button is unlocked, the feedback circuit (NC contacts K3, K4) is closed and the reset button is actuated and released again. When the emergency stop button is actuated, the safety switching device and the contactors K3, K4 switch off.

A failure of one of the switching elements of the emergency stop button or a cross-circuit between its feed cables does not lead to a failure of the emergency stop device. The problem is detected during the next switching on process.

Two-Channel Emergency Stop Monitor with Contact Expansion

Type of Device	SNO 4062K / SNE 4004K	
Category	Application (acc. to EN 954-1)	4
	Stop category (acc. to EN 60204-1)	0
Application Features	<ul style="list-style-type: none"> • 2-channel monitor • cross monitoring • ground-fault detection • manual, monitored reset • monitoring of the expansion device SNE and external contactors 	
Safety Sensors	Emergency stop button	
Remarks/Notes	The single-channel wiring between the base device and the expansion device complies with Category 4 according to EN 954-1 as long as installation takes place within a control cabinet and is short-circuit protected.	

1

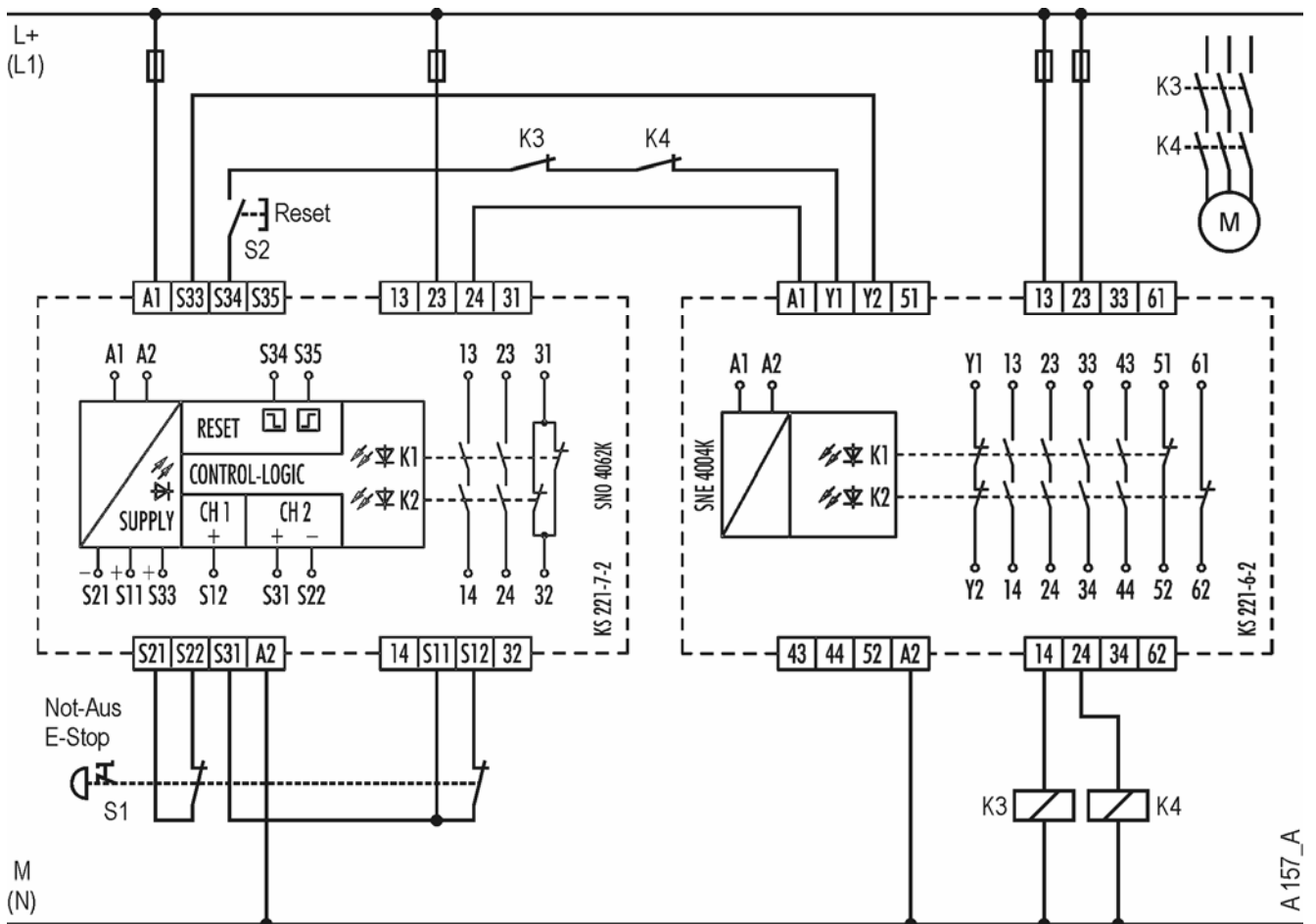

Two-channel emergency stop monitoring (cross monitoring) with manual, monitored reset and contact expansion.

The safety switching device, the expansion device and the contactors K3, K4 are switched on when the emergency stop button is unlocked, the feedback circuit (NC contacts of the expansion device Y1/Y2 and the contactors K3, K4) is closed and the reset button is actuated and released again.

When the emergency stop button is actuated, the safety switching device and the contactors K3, K4 switch off.

A failure of one of the switching elements of the emergency stop button or a cross-circuit between its feed cables does not lead to a failure of the emergency stop device. The problem is detected during the next switching on process.

Two-Channel Emergency Stop Monitor with Cable-Operated Emergency Switches

Type of Device	SNO 4062K	
Category	Application (acc. to EN 954-1)	4
	Stop category (acc. to EN 60204-1)	0
Application Features	<ul style="list-style-type: none"> • 2-channel monitor • cross monitoring • manual, monitored reset • monitoring of external contactors (EDM) 	
Safety Sensors	Cable-operated emergency switch	
Remarks/Notes	-	

1

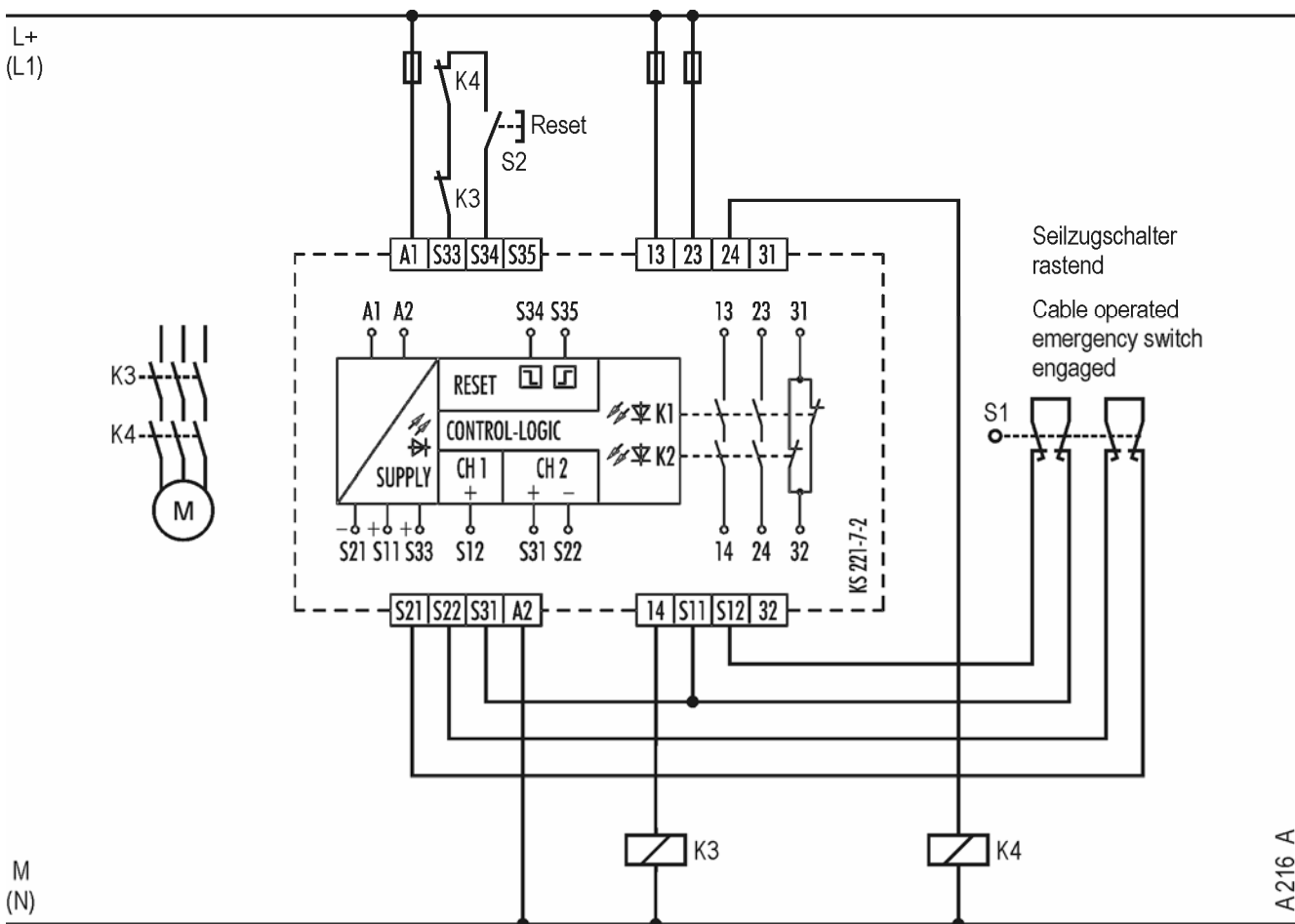

Two-channel emergency stop monitoring with cable-operated emergency switch (cross monitoring) and manual, monitored reset.

The safety switching device and the contactors K3, K4 are switched on when the cable-operated emergency switch and the feedback circuit (NC contacts K3, K4) are closed and the reset button is actuated and released again. When the cable-operated emergency switch is actuated, the safety switching device and the contactors K3, K4 switch off.

A failure of one of the switching elements of the emergency stop button or a cross-circuit between its feed cables does not lead to a failure of the emergency stop device. The problem is detected during the next switching on process.

Two-Channel Emergency Stop Monitor with Contact Expansion

Type of Device	SNO 4062K / SNE 4008S	
Category	Application (acc. to EN 954-1)	4
	Stop category (acc. to EN 60204-1)	0
Application Features	<ul style="list-style-type: none"> • 2-channel monitor • cross monitoring • ground-fault detection • manual, monitored reset • monitoring of the expansion device SNE and external contactors 	
Safety Sensors	Emergency stop button	
Remarks/Notes	The single-channel wiring between the base device and the expansion device complies with Category 4 according to EN 954-1 as long as installation takes place within a control cabinet and is short-circuit protected.	

1

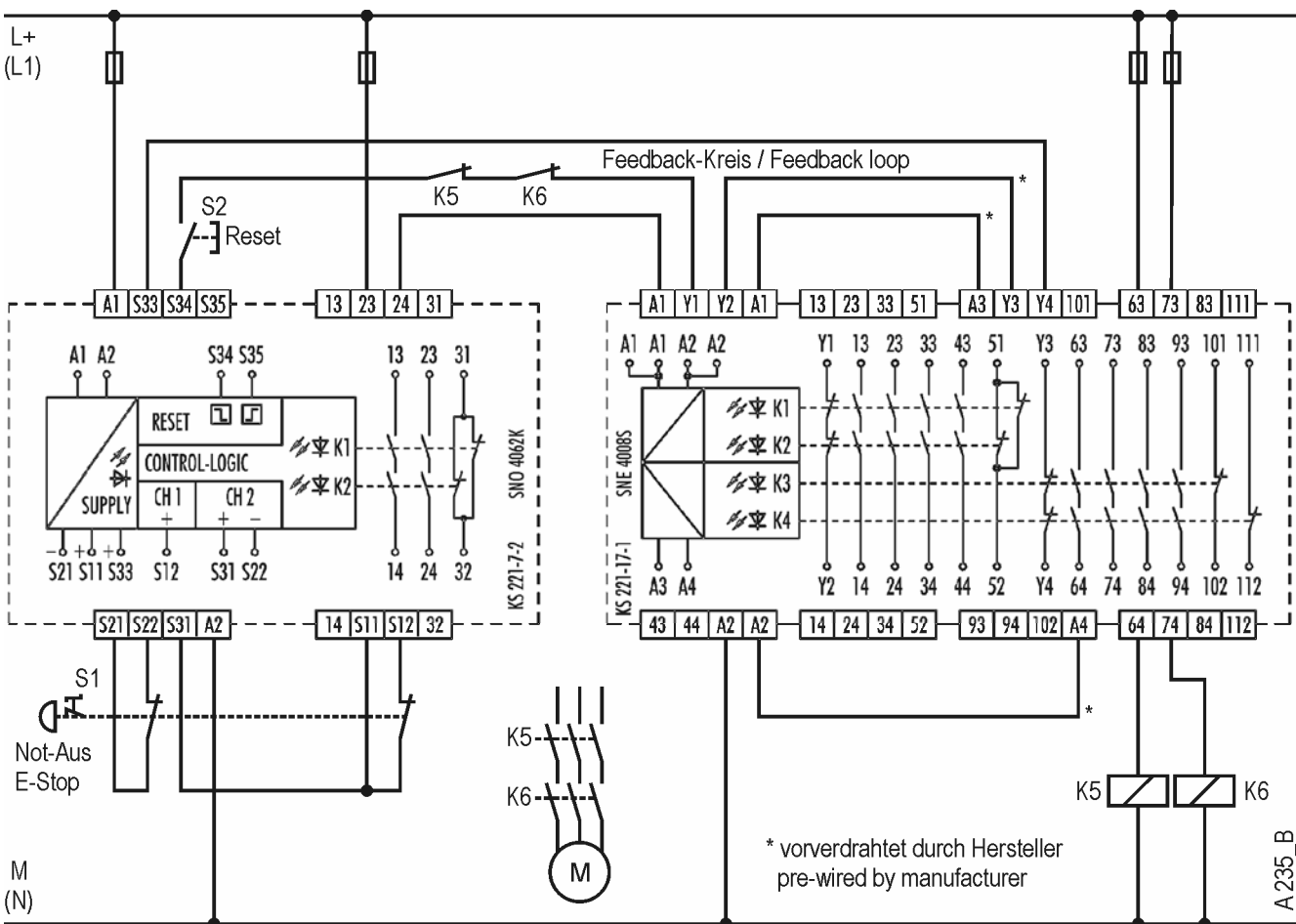

Two-channel emergency stop monitoring (cross monitoring) with manual, monitored reset and contact expansion.

The safety switching device, the expansion device and the contactors K5, K6 are switched on when the emergency stop button is unlocked, the feedback circuit (NC contacts of the expansion device Y1/Y2 and the contactors K5, K6) is closed and the reset button is actuated and released again.

When the emergency stop button is actuated, the safety switching device, the expansion device and the contactors K5, K6 switch off.

A failure of one of the switching elements of the emergency stop button or a cross-circuit between its feed cables does not lead to a failure of the emergency stop device. The problem is detected during the next switching on process.

Two-Channel Emergency Stop Monitor

Type of Device	SNO 4063K (AC/DC 24 V)	
Category	Application (acc. to EN 954-1)	4
	Stop category (acc. to EN 60204-1)	0
Application Features	<ul style="list-style-type: none"> • 2-channel monitor • cross monitoring • ground-fault detection • manual, monitored reset • monitoring of external contactors (EDM) 	
Safety Sensors	Emergency stop button	
Remarks/Notes	-	

1

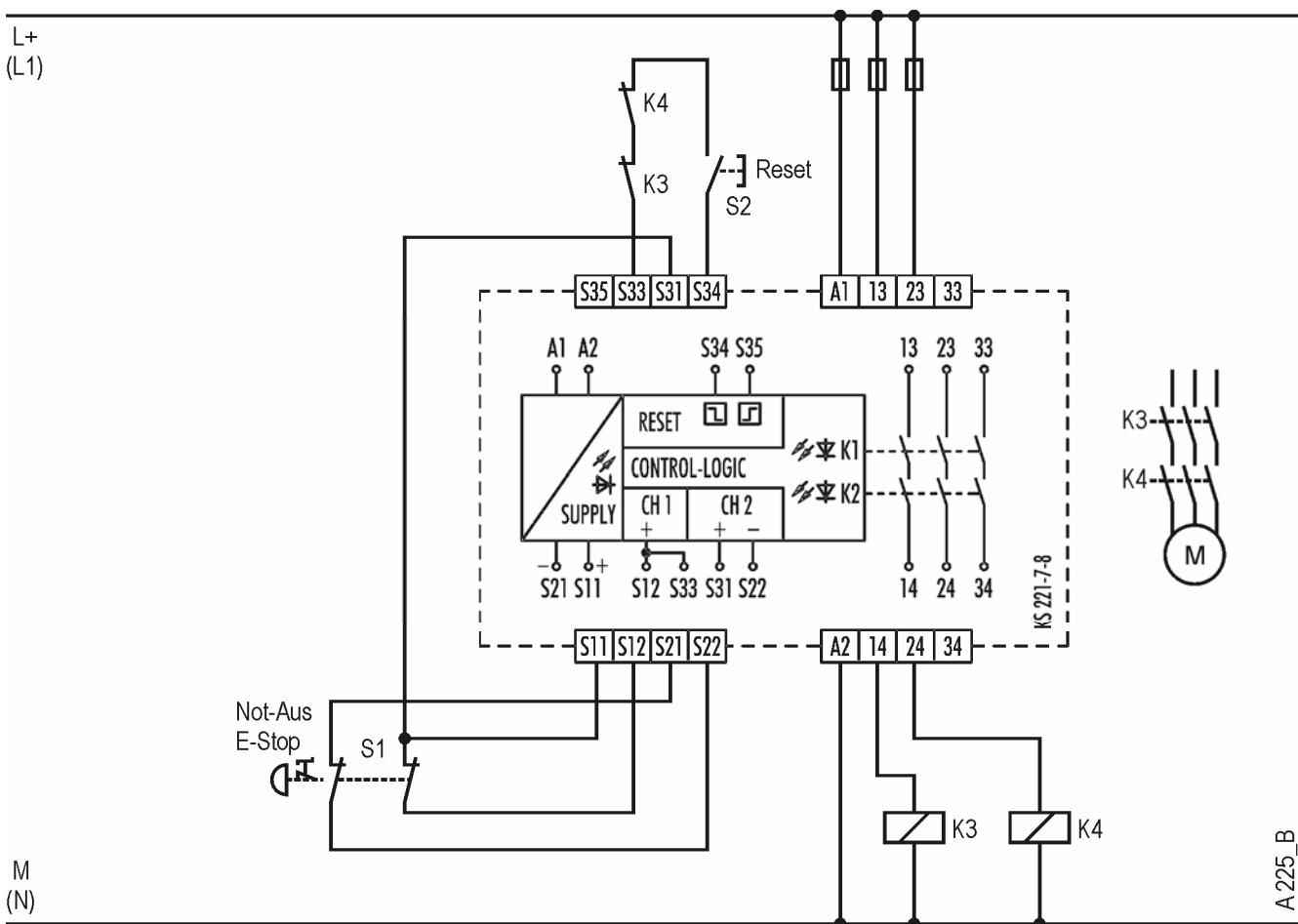

Two-channel emergency stop monitoring (cross monitoring) with manual, monitored reset.

The safety switching device and the contactors K3, K4 are switched on when the emergency stop button is unlocked, the feedback circuit (NC contacts K3, K4) is closed and the reset button is actuated and released again. When the emergency stop button is actuated, the safety switching device and the contactors K3, K4 switch off.

A failure of one of the switching elements of the emergency stop button or a cross-circuit between its feed cables does not lead to a failure of the emergency stop device. The problem is detected during the next switching on process.

Two-Channel Emergency Stop Monitor

Type of Device	SNT 4M63K (AC/DC 24 V)	
Category	Application (acc. to EN 954-1)	4
	Stop category (acc. to EN 60204-1)	0
Application Features	<ul style="list-style-type: none"> • 2-channel monitor • cross monitoring • ground-fault detection • manual, monitored reset • monitoring of external contactors (EDM) 	
Safety Sensors	Emergency stop button	
Remarks/Notes	-	

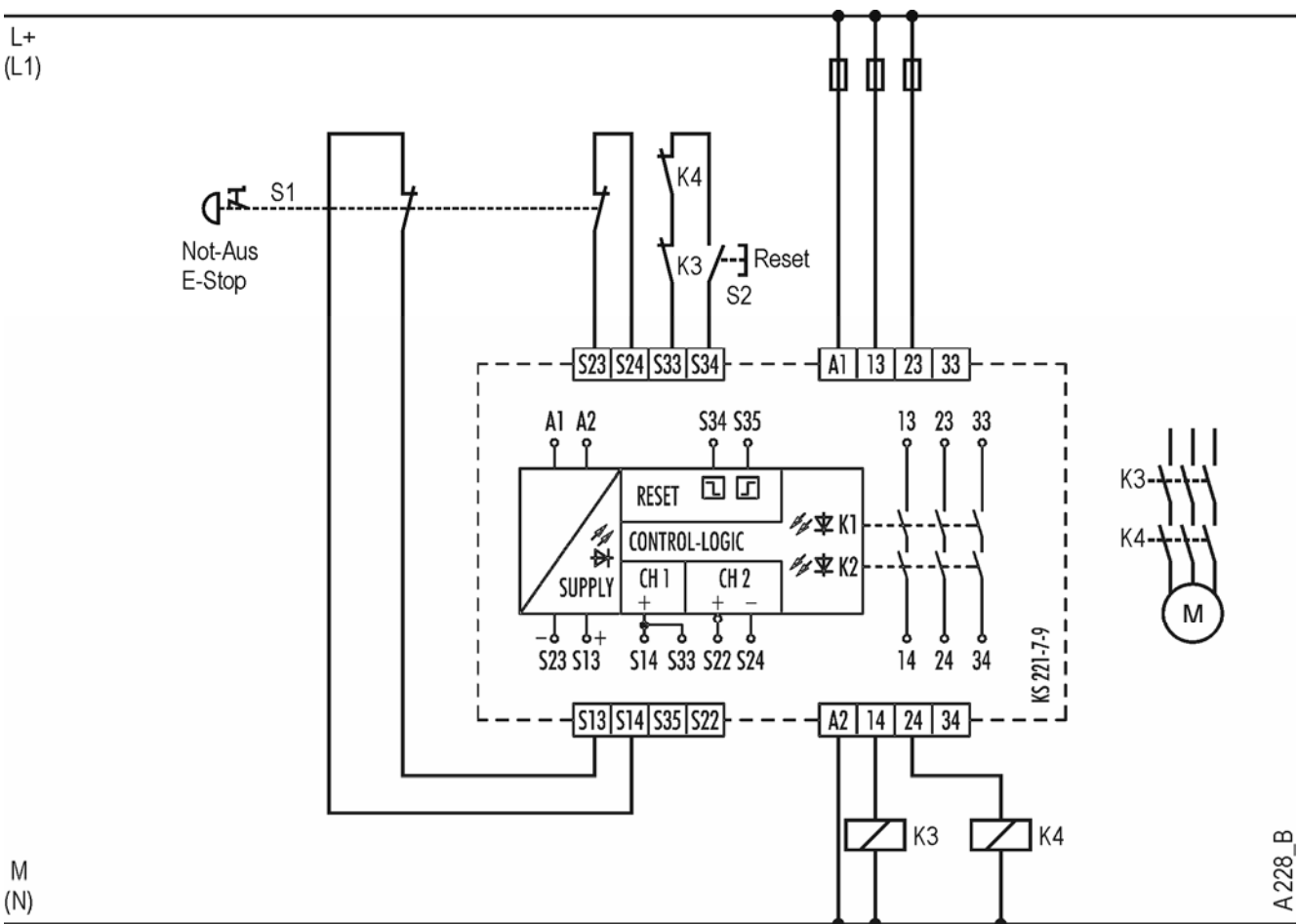

Two-channel emergency stop monitoring (cross monitoring) with manual, monitored reset.

The safety switching device and the contactors K3, K4 are switched on when the emergency stop button is unlocked, the feedback circuit (NC contacts K3, K4) is closed and the reset button is actuated and released again. When the emergency stop button is actuated, the safety switching device and the contactors K3, K4 switch off.

A failure of one of the switching elements of the emergency stop button or a cross-circuit between its feed cables does not lead to a failure of the emergency stop device. The problem is detected during the next switching on process.

Two-Channel Emergency Stop Monitor, Controlled Stop

Type of Device	SNV 4063KL	
Category	Application (acc. to EN 954-1) Stop category (acc. to EN 60204-1)	4 / 3 (Emergency stop / Safe OFF-delay) 1
Application Features	<ul style="list-style-type: none"> • 2-channel monitor • cross monitoring • ground-fault detection • manual, monitored reset • OFF-delay • monitoring of external contactors (EDM) 	
Safety Sensors	Emergency stop button	
Remarks/Notes	If the Safety devices are in the same control cabinet or protective wiring is used then 1-channel control of the contactors/expansion devices is acceptable.	

1

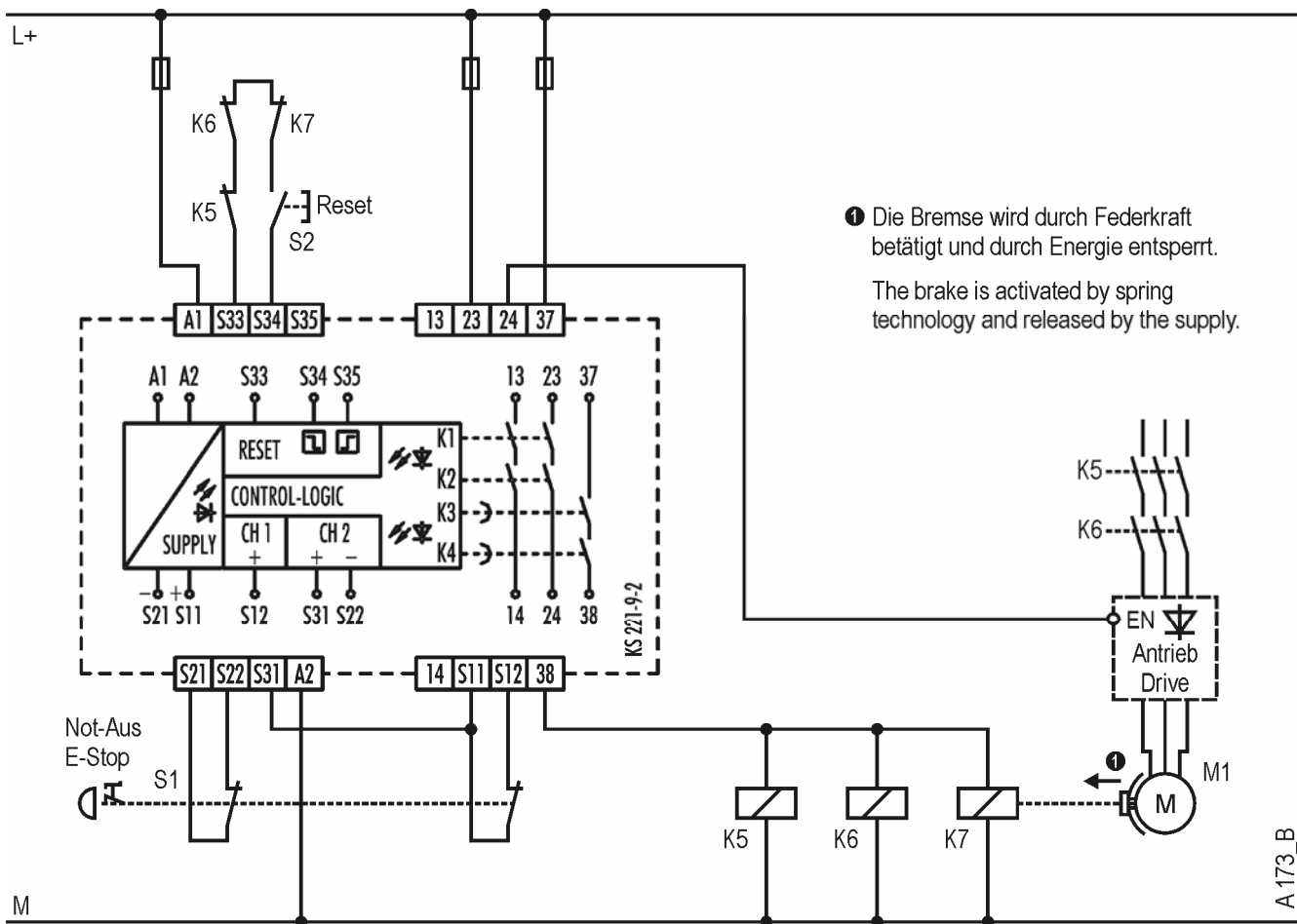

Two-channel emergency stop monitoring (cross monitoring) with manual, monitored reset.

The safety switching device and the contactors K5, K6 are switched on and the brake is released by K7 when the emergency stop button is unlocked, the feedback circuit (NC contacts K5, K6, K7) is closed and the reset button is actuated and released again. When the emergency stop button is actuated, the drive control enable input is switched off and the drive is powered down. After the

OFF-delay has elapsed, the contactors K5, K6 are switched off and the brake is applied by K7.

A failure of one of the switching elements of the emergency stop button or a cross-circuit between its feed cables does not lead to a failure of the emergency stop device. The problem is detected during the next switching on process.

2 Safety Gate

Cat-egory ¹⁾	Device	Safety sensors Features	Reset / start and restart inhibit	Stop category ²⁾	Applica-tion number	Page
2	SNO 2004K	Position switch	automatic	0	A 283	2 • 2
	SNO 4003K	Position switch	automatic	0	A 152	2 • 3
	SNO 4062K	Position switch	automatic	0	A 219	2 • 4
	SNO 4062K	Electronic position switch	manual, monitor	0	A 242	2 • 5
	SNV 4063KL	Position switch, OFF-delay	automatic	1	A 220	2 • 6
	SNO 5002K	Position switch	automatic	0	A 285	2 • 7
3	<i>samos</i>	2 safety zones, position switches, higher-priority emergency stop, OFF-delay	manual, monitor / automatic	0/1 ³⁾	A 253	2 • 8
	<i>samos</i>	2 safety zones, magnetic switches, higher-priority emergency stop	manual, monitor	0	A 258	2 • 9
	SNO 4062K	3-wire proximity sensors (SC)	automatic	0	A 165	2 • 10
	SNO 4062K	Electronic position switch	manual, monitor	0	A 230	2 • 11
	SNT 4M63K	Position switch with tumbler	automatic	0	A 232	2 • 12
	SNV 4063KL	Position switch with tumbler, OFF-delay	automatic	1	A 181	2 • 13
	SNV 4063KP	Position switch with tumbler, ON-delay	manual, monitor	1	A 176	2 • 14
	4	<i>samos</i>	Emergency stop button, position switches, ESPE type 4 (SC), inductive sensor, OFF-delay	manual, monitor	1	A 268
<i>samos</i>		Position switches, key lock switch, OFF-delay	automatic	1	A 269	2 • 16
SNA 4043K		Position switches	automatic	0	A 274	2 • 17
SNO 4062K		Position switches, synchrocheck	automatic	0	A 155	2 • 18
SNO 4062K		Electronic position switches	automatic	0	A 243	2 • 19
SNO 4063K		Position switches, synchrocheck	automatic	0	A 226	2 • 20
SNO 4063K		Electronic position switches	automatic	0	A 244	2 • 21
SNT 4M63K		Position switches, synchrocheck	automatic	0	A 221	2 • 22
SNT 4M63K		Position switches, synchrocheck	automatic	0	A 222	2 • 23
SNT 4M63K		Magnetic switch	automatic	0	A 233	2 • 24
SNT 4M63K		Magnetic switch	manual, monitor	0	A 234	2 • 25
SNV 4063KL		Position switches, OFF-delay, synchrocheck	automatic	1	A 174	2 • 26

¹⁾ acc. to EN 954-1 ²⁾ acc. to EN 60204-1 ³⁾ instantaneous/delayed enables

Single-Channel Safety Gate Monitor

Type of Device	SNO 2004K	
Category	Application (acc. to EN 954-1)	2
	Stop category (acc. to EN 60204-1)	0
Application Features	<ul style="list-style-type: none"> • 1-channel monitor • ground-fault detection • automatic reset • monitoring of external contactors (EDM) 	
Safety Sensors	Position switch	
Remarks/Notes	<p>(1) If the Safety devices are in the same control cabinet or protective wiring is used then 1-channel control of the contactors/expansion devices is acceptable.</p> <p>(2) Refer to the Section "Terms" for information on connecting position switches in series.</p>	

2

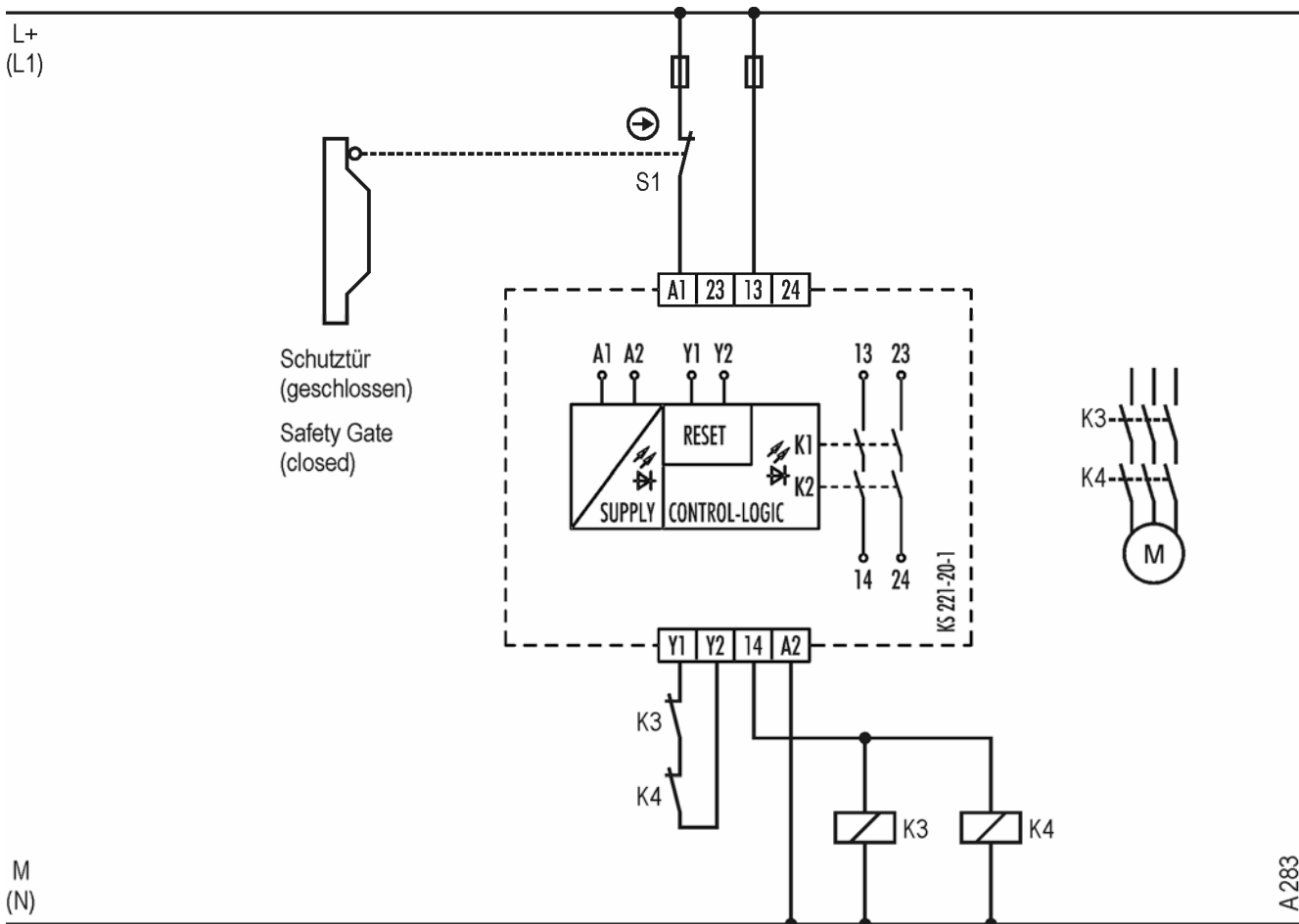

Single-channel safety gate monitoring with manual reset.

The safety switching device and the contactors K3, K4 are switched on when the NC contact of the position switch and the feedback circuit (NC contacts K3, K4) are closed and the reset button is actuated. If the NC contact of the position switch is opened, the safety switching device and the contactors K3, K4 switch off.

Caution: The protective devices must be tested regularly via machine control or manually (organizational measure). Category 2 according to EN 954-1 can only be attained when an automatic warning is issued on actuator failure or the machine control initiates a safe status. Otherwise, a second switch-off method is necessary.

Single-Channel Safety Gate Monitor

Type of Device	SNO 4003K (AC 230 V)
Category	Application (acc. to EN 954-1) Stop category (acc. to EN 60204-1)
Application Features	<ul style="list-style-type: none"> • 1-channel monitor • automatic reset • monitoring of external contactors (EDM)
Safety Sensors	Position switch
Remarks/Notes	<p>(1) If the Safety devices are in the same control cabinet or protective wiring is used then 1-channel control of the contactors/expansion devices is acceptable.</p> <p>(2) Refer to the Section "Terms" for information on connecting position switches in series.</p> <p>(3) The maximum cable length listed in the technical data must be observed.</p>

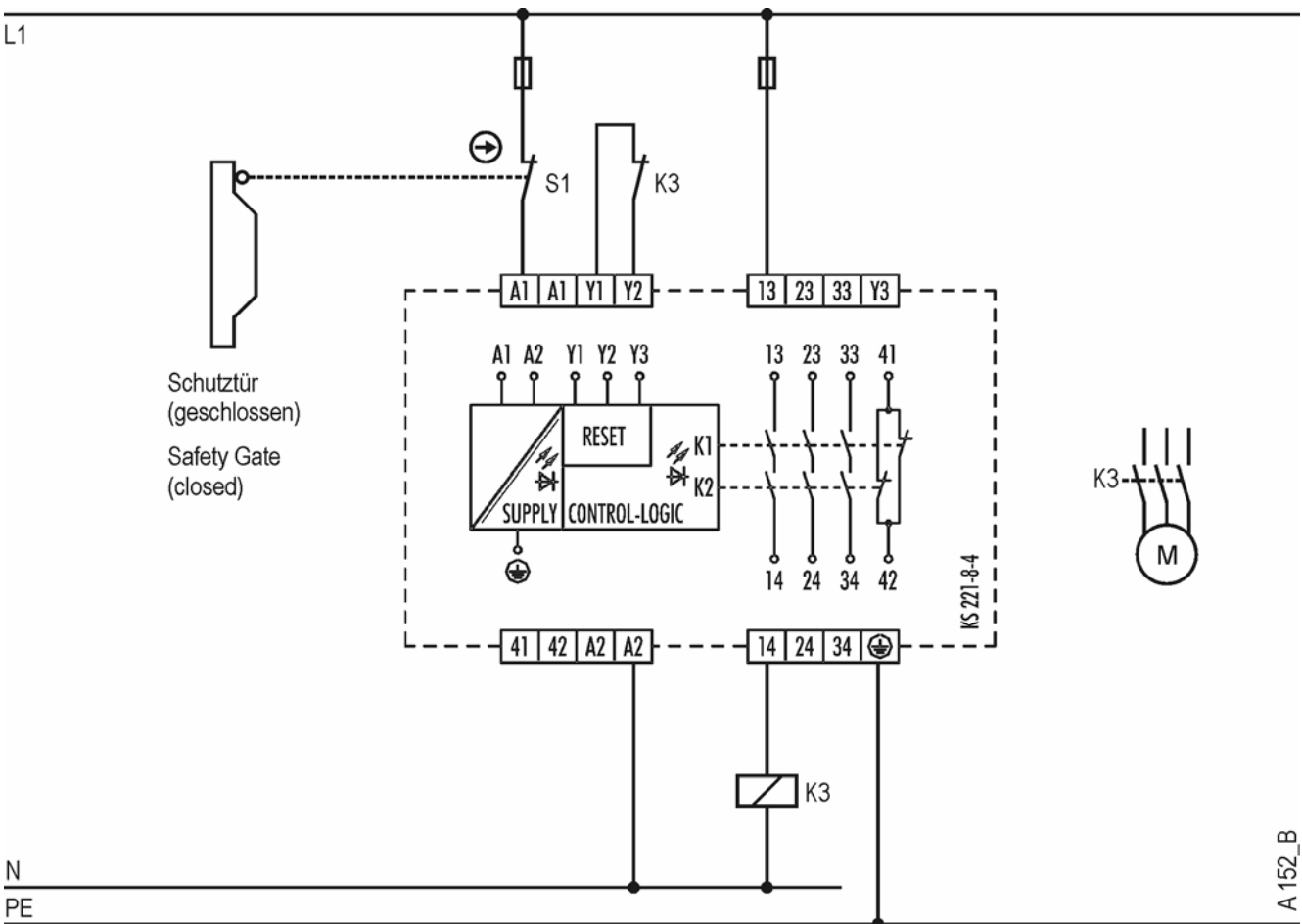

Single-channel safety gate monitoring with manual reset.

The safety switching device and the contactor K3 are switched on when the NC contact of the position switch and the feedback circuit (NC contact K3) are closed. If the NC contact of the position switch is opened, the safety switching device and the contactor K3 switch off.

Caution: The protective devices must be tested regularly via machine control or manually (organizational measure). Category 2 according to EN 954-1 can only be attained when an automatic warning is issued on actuator failure or the machine control initiates a safe status. Otherwise, a second switch-off method is necessary.

Single-Channel Safety Gate Monitor

Type of Device	SNO 4062K	
Category	Application (acc. to EN 954-1)	2
	Stop category (acc. to EN 60204-1)	0
Application Features	<ul style="list-style-type: none"> • 1-channel monitor • automatic reset • monitoring of external contactors (EDM) 	
Safety Sensors	Position switch	
Remarks/Notes	<p>(1) If the Safety devices are in the same control cabinet or protective wiring is used then 1-channel control of the contactors/expansion devices is acceptable.</p> <p>(2) Refer to the Section "Terms" for information on connecting position switches in series.</p>	

2

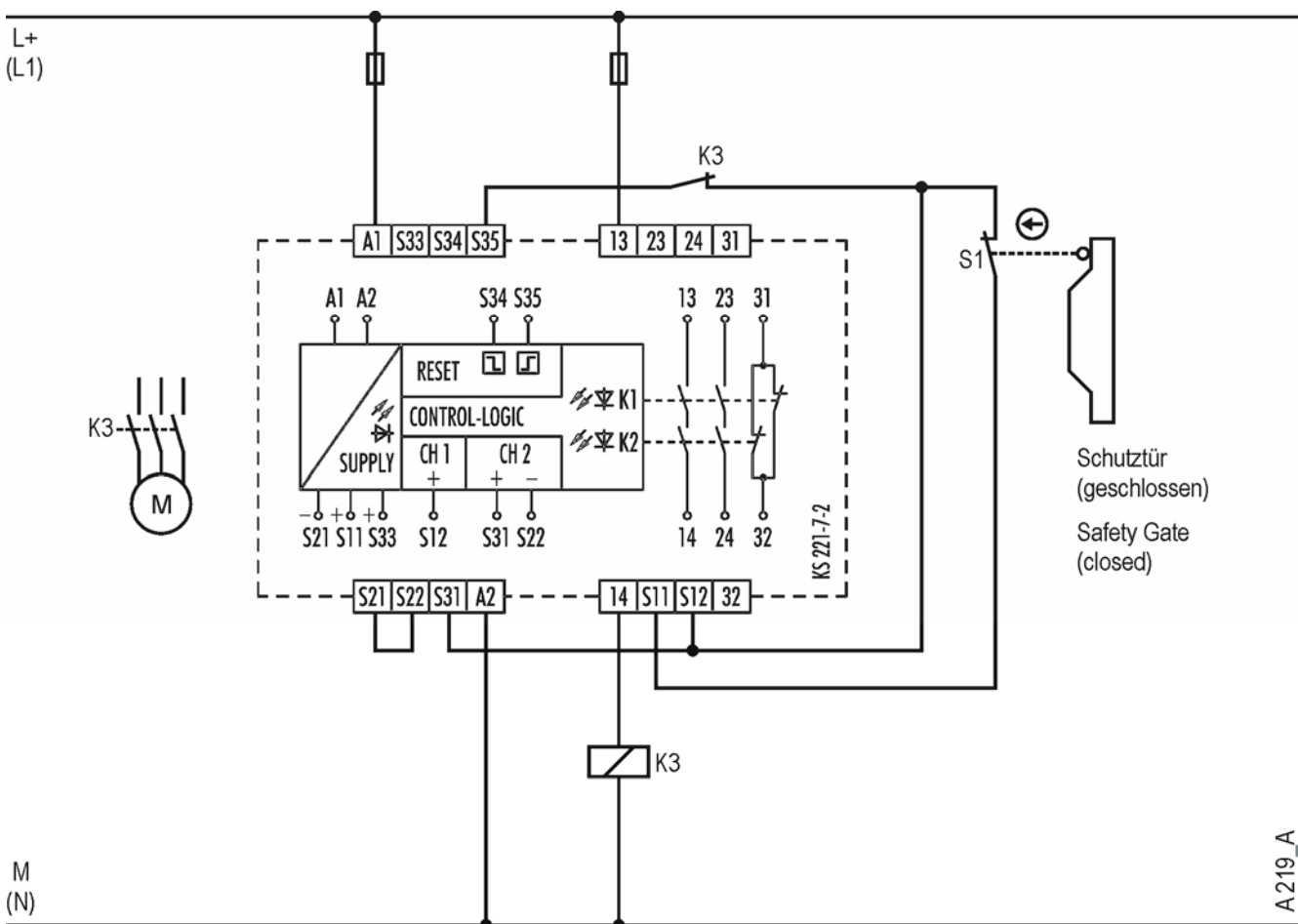

Single-channel safety gate monitoring with manual reset.

The safety switching device and the contactor K3 are switched on when the NC contact of the position switch and the feedback circuit (NC contact K3) are closed. If the NC contact of the position switch is opened, the safety switching device and the contactor K3 switch off.

Caution: The protective devices must be tested regularly via machine control or manually (organizational measure). Category 2 according to EN 954-1 can only be attained when an automatic warning is issued on actuator failure or the machine control initiates a safe status. Otherwise, a second switch-off method is necessary.

Single-Channel Safety Gate Monitor

Type of Device	SNO 4062K	
Category	Application (acc. to EN 954-1)	2
	Stop category (acc. to EN 60204-1)	0
Application Features	<ul style="list-style-type: none"> • 1-channel monitor • ground-fault detection • manual, monitored reset • monitoring of external contactors (EDM) • self test of command device • OSSD compatible 	
Safety Sensors	Electronic position switch, type LSE11, Moeller	
Remarks/Notes	<p>(1) If the Safety devices are in the same control cabinet or protective wiring is used then 1-channel control of the contactors/expansion devices is acceptable.</p> <p>(2) Refer to the Section "Terms" for information on connecting position switches in series.</p> <p>(3) OSSD has high level when the switch is in "OK" position.</p>	

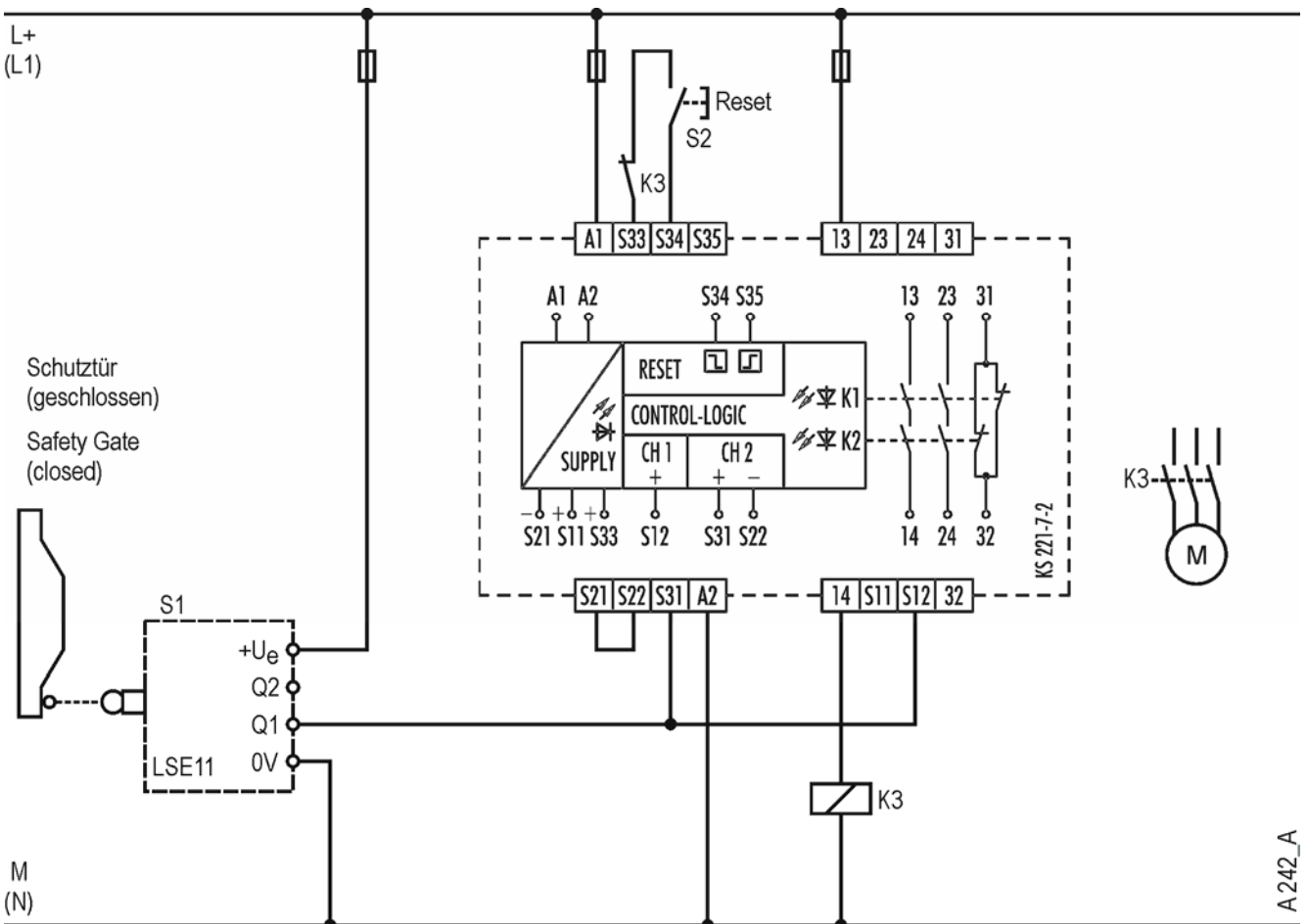

Single-channel safety gate monitoring with manual, monitored reset.

The safety switching device and the contactor K3 are switched on when the output Q1 of the non-actuated position switch issues a HIGH signal and the feedback circuit (NC contact K3) is closed. If the output Q1 of the position switch issues a LOW signal, the safety switching device and the contactor K3 switch off.

Caution: The protective devices must be tested regularly via machine control or manually (organizational measure). Category 2 according to EN 954-1 can only be attained when an automatic warning is issued on actuator failure or the machine control initiates a safe status. Otherwise, a second switch-off method is necessary.

Single-Channel Safety Gate Monitor

Type of Device	SNV 4063KL	
Category	Application (acc. to EN 954-1)	2
	Stop category (acc. to EN 60204-1)	1
Application Features	<ul style="list-style-type: none"> • 1-channel monitor • ground-fault detection • automatic reset • OFF-delay • monitoring of external contactors (EDM) • no synchrocheck available 	
Safety Sensors	Position switch	
Remarks/Notes	Refer to the Section "Terms" for information on connecting position switches in series.	

2

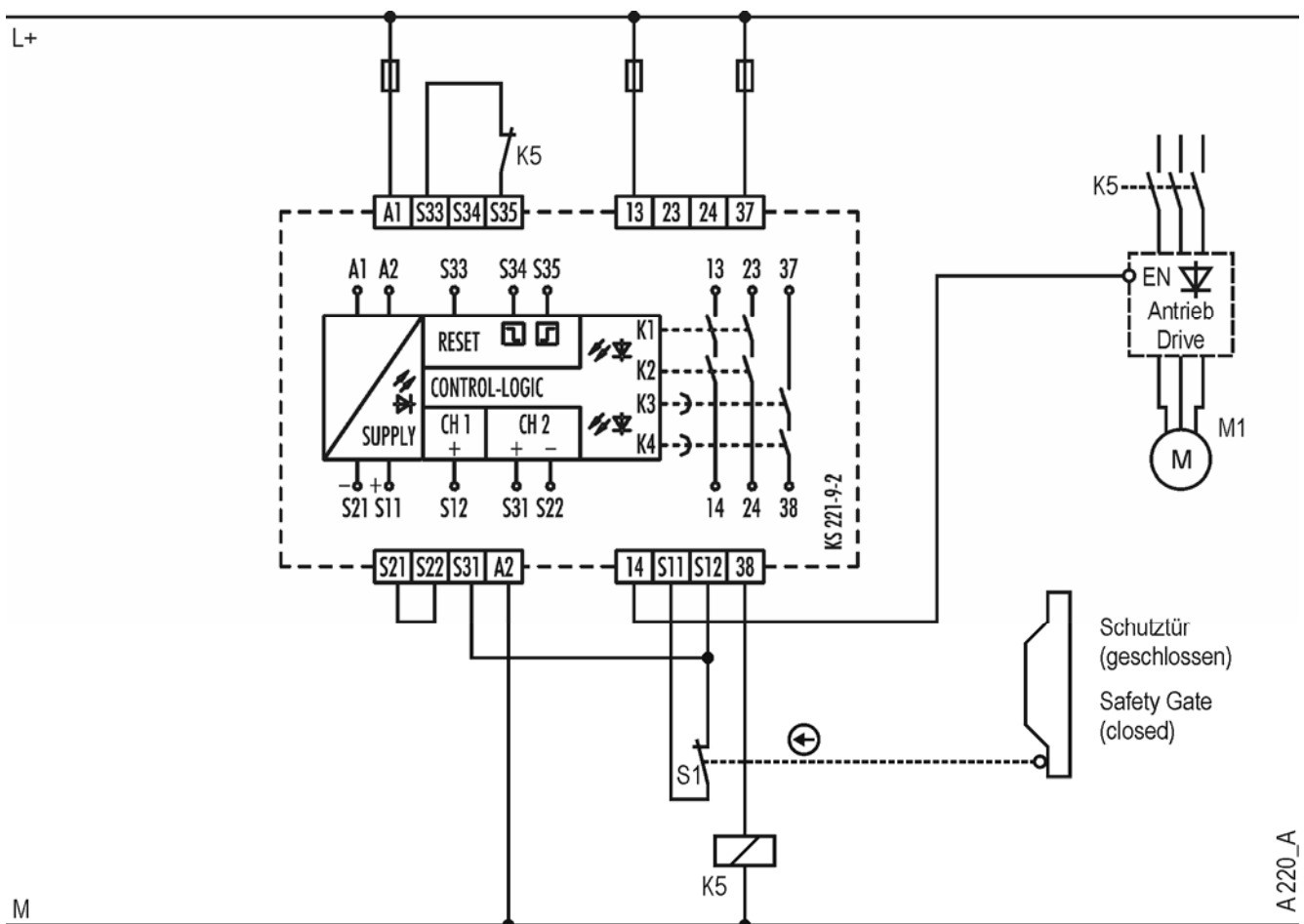

Single-channel safety gate monitoring with automatic reset.

The safety switching device and the contactor K5 are switched on when the NC contact of the position switch and the feedback circuit (NC contact K5) are closed. If the NC contact of the position switch is opened, the drive control enable input is switched off. After the OFF-delay has elapsed, the contactor K5 switches off.

Caution: The protective devices must be tested regularly via machine control or manually (organizational measure). Category 2 according to EN 954-1 can only be attained when an automatic warning is issued on actuator failure or the machine control initiates a safe status. Otherwise, a second switch-off method is necessary.

Single-Channel Safety Gate Monitor

Type of Device	SNO 5002K (DC 24 V)	
Category	Application (acc. to EN 954-1)	2
	Stop category (acc. to EN 60204-1)	0
Application Features	<ul style="list-style-type: none"> • 1-channel monitor • ground-fault detection • automatic reset • monitoring of external contactors (EDM) 	
Safety Sensors	Position switch	
Remarks/Notes	Refer to the Section "Terms" for information on connecting position switches in series.	

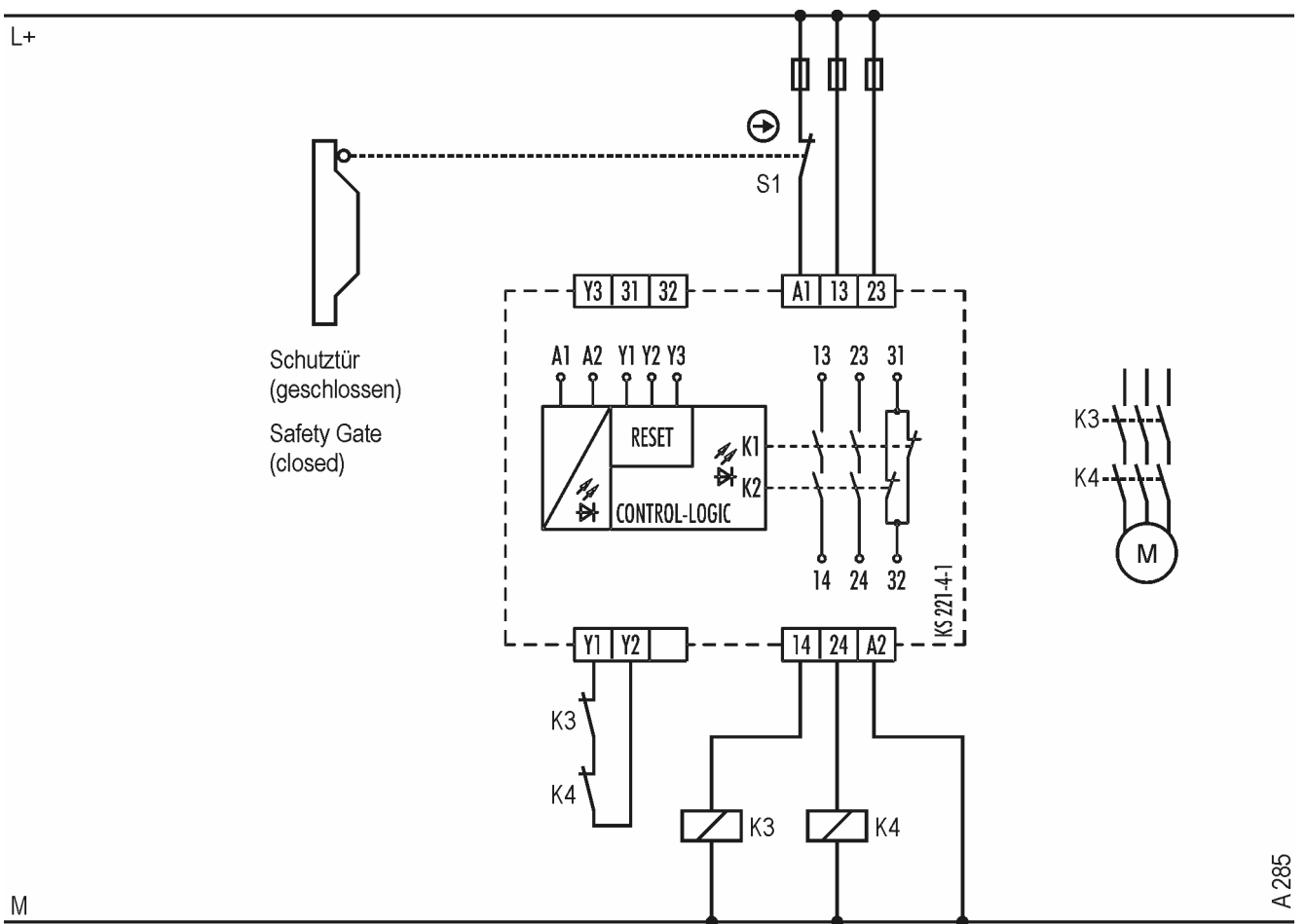

Single-channel safety gate monitoring with automatic reset.

The safety switching device and the contactors K3, K4 are switched on when the NC contact of the position switch and the feedback circuit (NC contacts K3, K4) are closed. If the NC contact of the position switch is opened, the safety switching device and the contactors K3, K4 switch off.

Caution: The protective devices must be tested regularly via machine control or manually (organizational measure). Category 2 according to EN 954-1 can only be attained when an automatic warning is issued on actuator failure or the machine control initiates a safe status. Otherwise, a second switch-off method is necessary.

Two Safety Zones Monitor, Safety Gate Monitor with Higher-Priority Emergency Stop

Type of Device	SA-BM-S1	
Category	Application (acc. to EN 954-1)	3
	Stop category (acc. to EN 60204-1)	0 / 1 (Emergency stop / Safety gate)
Application Features	<ul style="list-style-type: none"> • 2-channel monitor • ground-fault detection • manual, monitored reset for emergency stop, automatic reset for safety gate • OFF-delay • monitoring of external contactors (EDM) 	
Safety Sensors	Emergency stop buttons, position switches	
Remarks/Notes	<p>(1) Refer to the Section "Terms" for information on connecting position switches in series.</p> <p>(2) <i>samos</i> modules and contactors in the same enclosure.</p>	

2

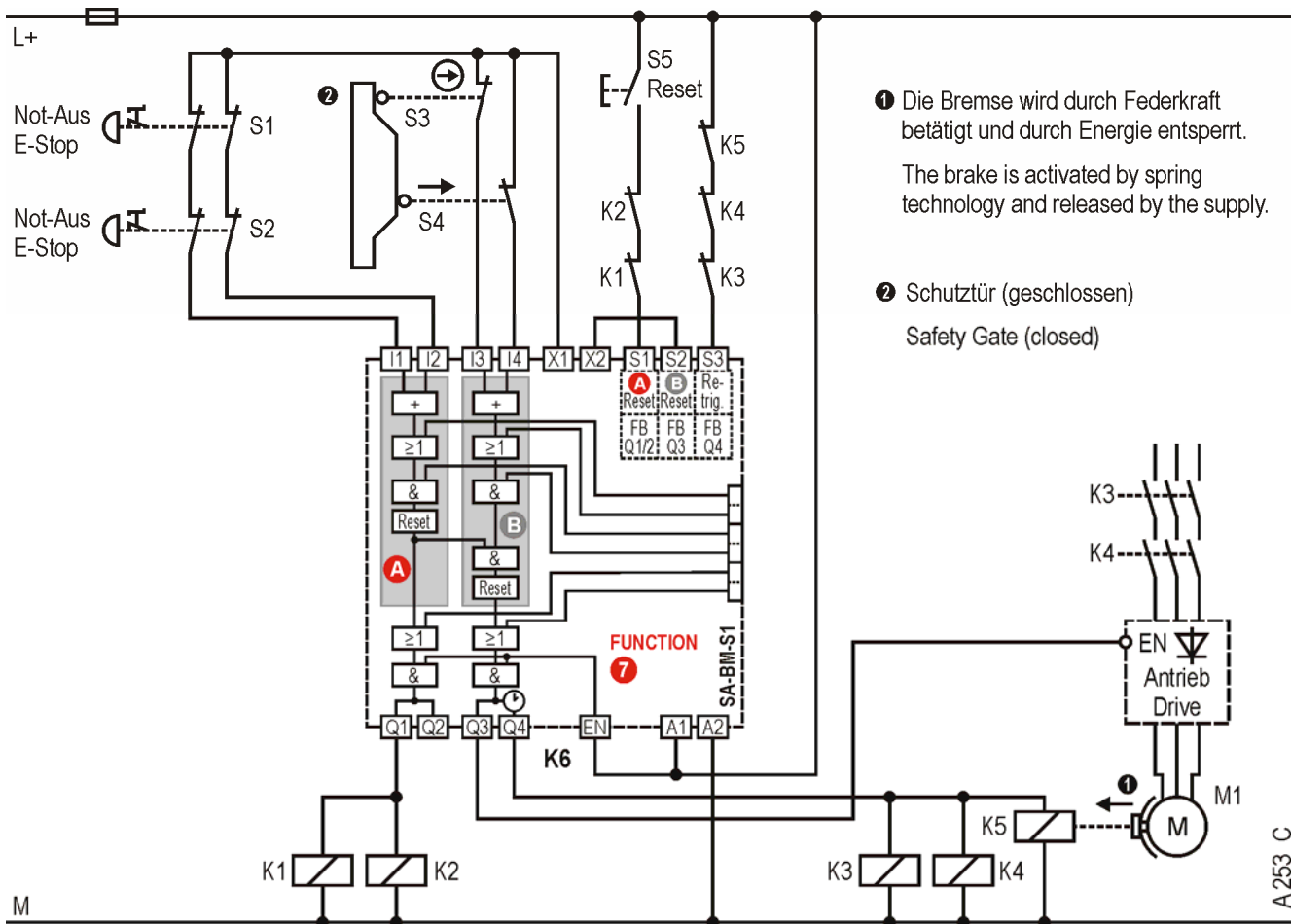

Two-channel emergency stop and safety gate monitoring with higher-priority emergency stop

In case of emergency stop contactors K1, K2 and output Q3 shut down immediately. The drive shuts down immediately via the enable signal. After the preset time power to the drive is switched off via K3, K4 and a brake applied via K5 (safe stopping according to stop category 1).

Start after emergency stop and after power on is with reset. When the safety gate is opened only the drive is stopped safely. K1 and K2 remain switched on. After the safety gate has been closed and the feedback circuits checked, the safety device is reset automatically. The machine is ready to switch on.

Two Independent Safety Zones Monitor with Magnetic Switches, Higher-Priority Emergency Stop

Type of Device	SA-BM-S1 / SA-IN-S1
Category	Application (acc. to EN 954-1) Stop category (acc. to EN 60204-1)
Application Features	<ul style="list-style-type: none"> • 2-channel monitor • ground-fault detection • manual, monitored reset • monitoring of external contactors (EDM)
Safety Sensors	Emergency stop button, magnetic switches with coded magnet
Remarks/Notes	<p>(1) Refer to the Section "Terms" for information on connecting position switches in series.</p> <p>(2) <i>samos</i> modules and contactors in the same enclosure.</p>

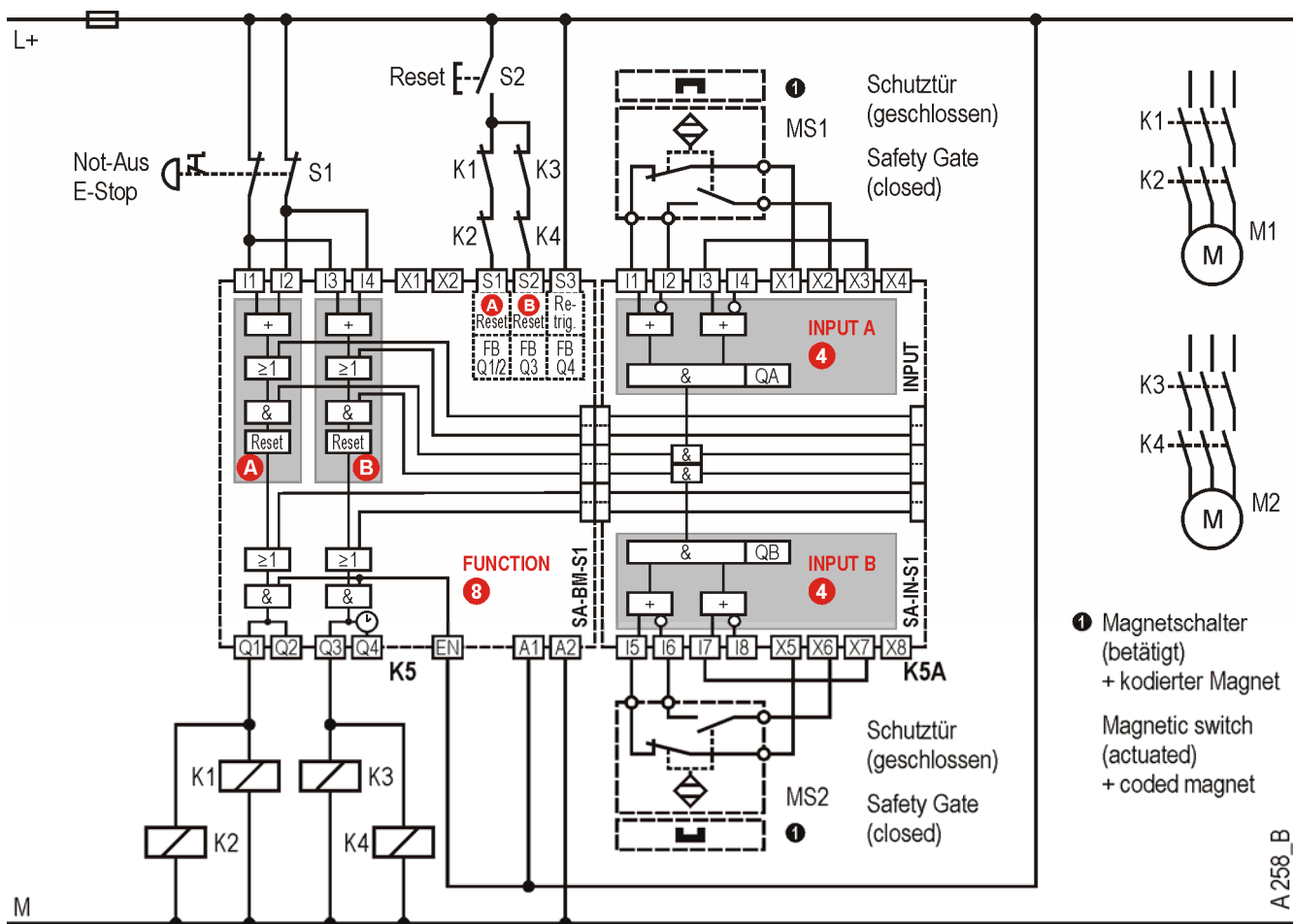

Two-channel emergency stop and safety gate monitoring with higher-priority emergency stop.

When the safety gate monitored with MS1 is opened, K1 and K2 are switched off. When the safety gate monitored with MS2 is opened, K3 and K4 are switched off. In case of emergency stop via S1, all contactors K1 to K4 are switched off.

With button S2 you can reset the safety system while the safety devices are closed.

Reset button S2 is monitored for faults. The contactors K1 to K4 are monitored via NC contacts in the feedback circuit.

With two-channel monitoring a parallel opening/closing and closing/opening of both channels is required for a new enabling.

Two-Channel Safety Gate Monitor with Proximity Sensors

Type of Device	SNO 4062K	
Category	Application (acc. to EN 954-1)	3
	Stop category (acc. to EN 60204-1)	0
Application Features	<ul style="list-style-type: none"> • 2-channel monitor • cross monitoring • automatic reset • monitoring of external contactors (EDM) • OSSD compatible 	
Safety Sensors	3-wire proximity sensors with semiconductor outputs Types: S1 = IF 5249, S2 = IF 5251, ifm	
Remarks/Notes	Refer to the Section "Terms" for information on connecting position switches in series.	

2

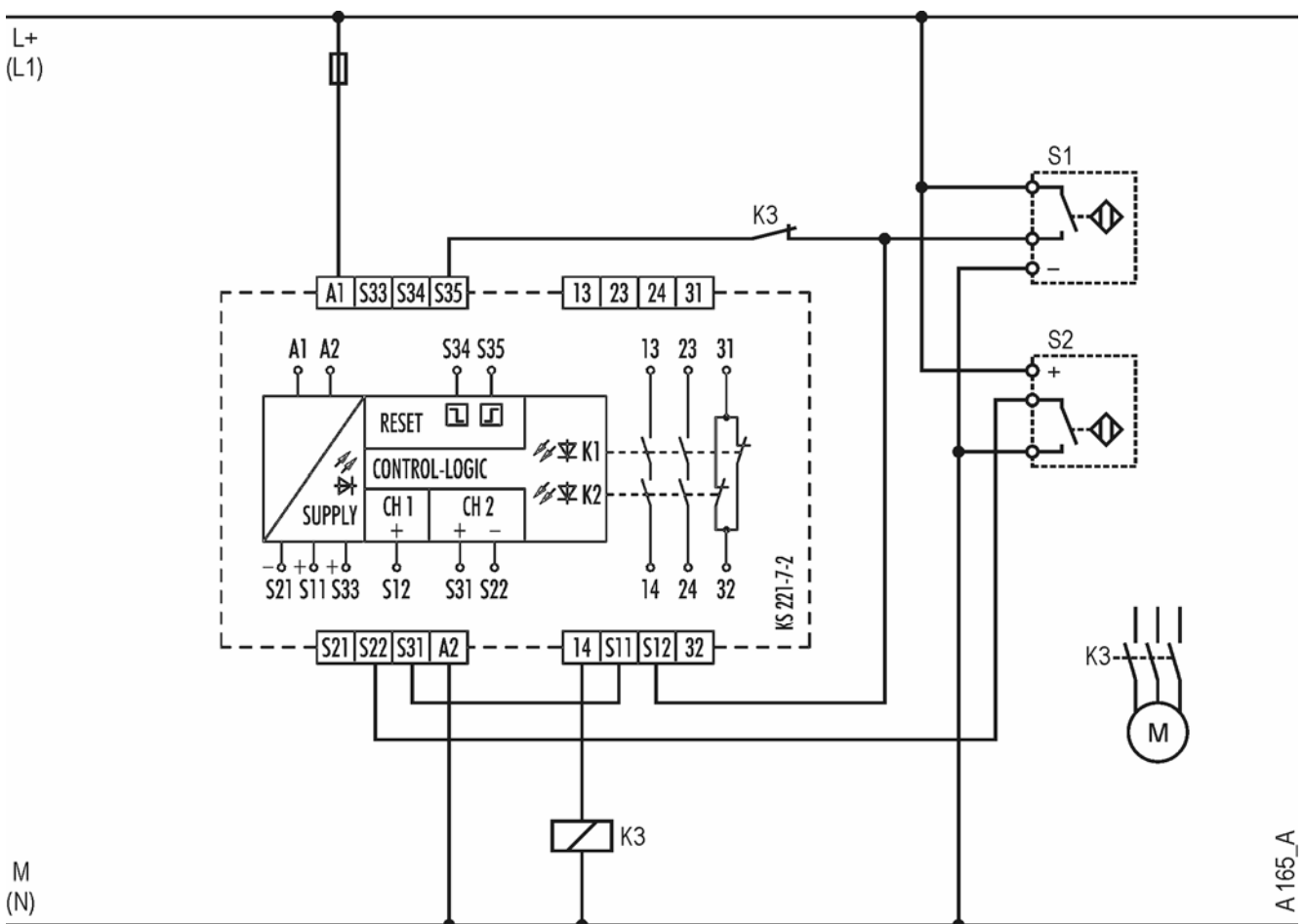

Two-channel safety gate monitoring (cross monitoring) with automatic reset.

The safety switching device and the contactor K3 are switched on when the output of the proximity switch S1 issues a HIGH signal, the output of the proximity switch S2 issues a LOW signal and the feedback circuit (NC contact K3) is closed. If S1 issues a LOW signal and/or S2 issues a HIGH signal, the safety switching device and the contactor K3 are switched off.

A failure of one of the proximity switches or a crossover in their supply lines does not lead to a failure of the safety gate monitoring. The problem is detected before the next switching on process.

Two-Channel Safety Gate Monitor

Type of Device	SNO 4062K
Category	Application (acc. to EN 954-1) Stop category (acc. to EN 60204-1)
Application Features	<ul style="list-style-type: none"> • 2-channel monitor • manual, monitored reset • monitoring of external contactors (EDM) • self test of command device • OSSD compatible
Safety Sensors	Electronic position switch, type LSE02, Moeller
Remarks/Notes	<p>(1) If the Safety devices are in the same control cabinet or protective wiring is used then 1-channel control of the contactors/expansion devices is acceptable.</p> <p>(2) Refer to the Section "Terms" for information on connecting position switches in series.</p> <p>(3) OSSD has high level when the switch is in "OK" position.</p>

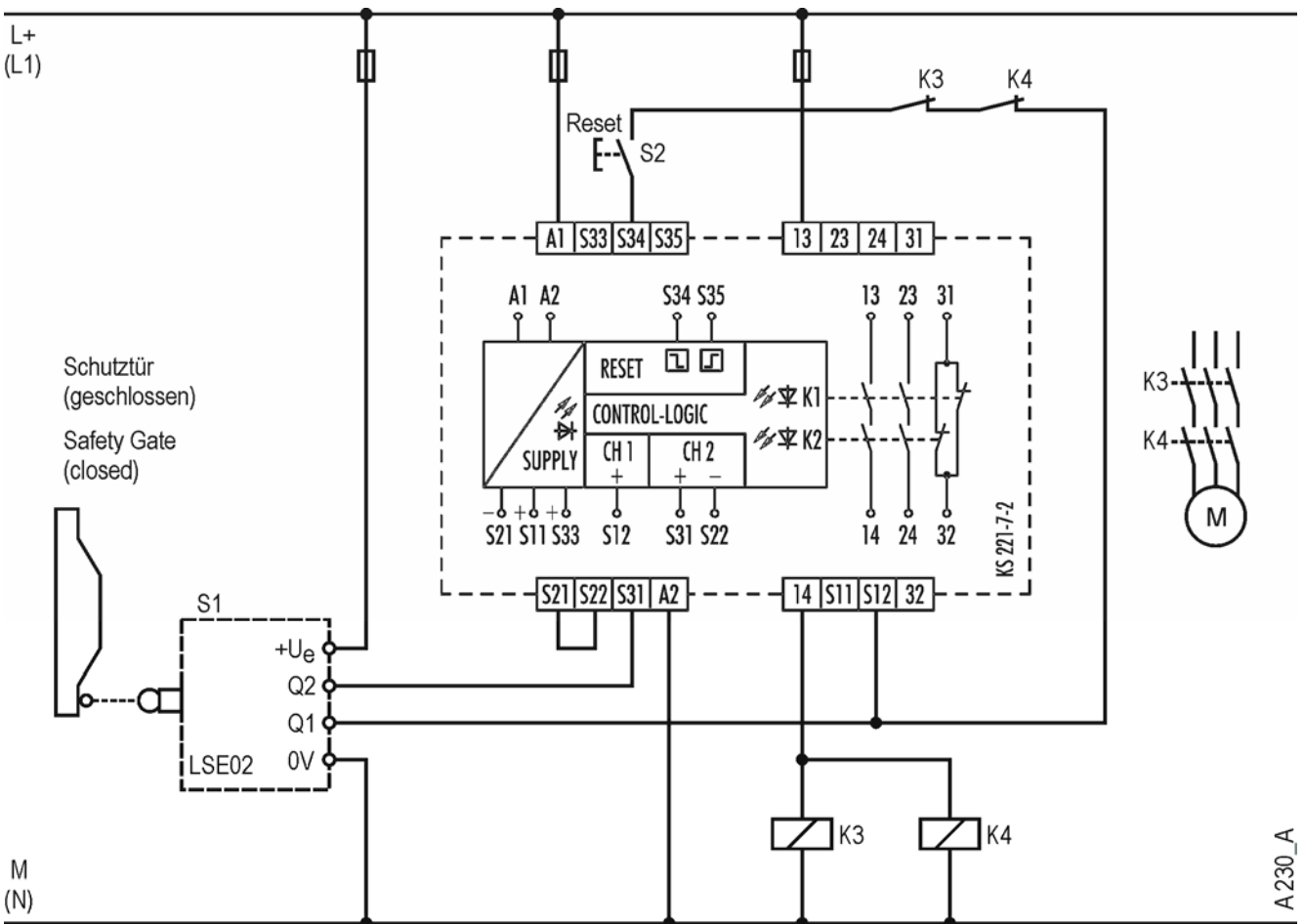

Two-channel safety gate monitoring with manual, monitored reset.

The safety switching device and the contactors K3, K4 are switched on when the outputs Q1, Q2 of the non-actuated position switch issue a HIGH signal and the feedback circuit (NC contact K3, K4) is closed. If one of the outputs

Q1 or Q2 of the position switch issues a LOW signal, the safety switching device and the contactors K3, K4 switch off.

A failure of the positioning switch does not lead to a failure of the safety gate monitoring. The problem is detected during the next switching on process.

Two-Channel Safety Gate Monitor, Tumbler Activated by Spring Technology

Type of Device	SNT 4M63K (AC 115-120 V, AC 230 V)	
Category	Application (acc. to EN 954-1)	3
	Stop category (acc. to EN 60204-1)	0
Application Features	<ul style="list-style-type: none"> • 2-channel monitor • cross monitoring • ground-fault detection • automatic reset • monitoring of external contactors (EDM) 	
Safety Sensors	Position switch with tumbler Type LS-S02-...FT-ZBZ/X, Moeller	
Remarks/Notes	<p>(1) Fault exclusion "Cancel or release of the actuator, fault in safety locking mechanism".</p> <p>(2) Refer to the Section "Terms" for information on connecting position switches in series.</p>	

2

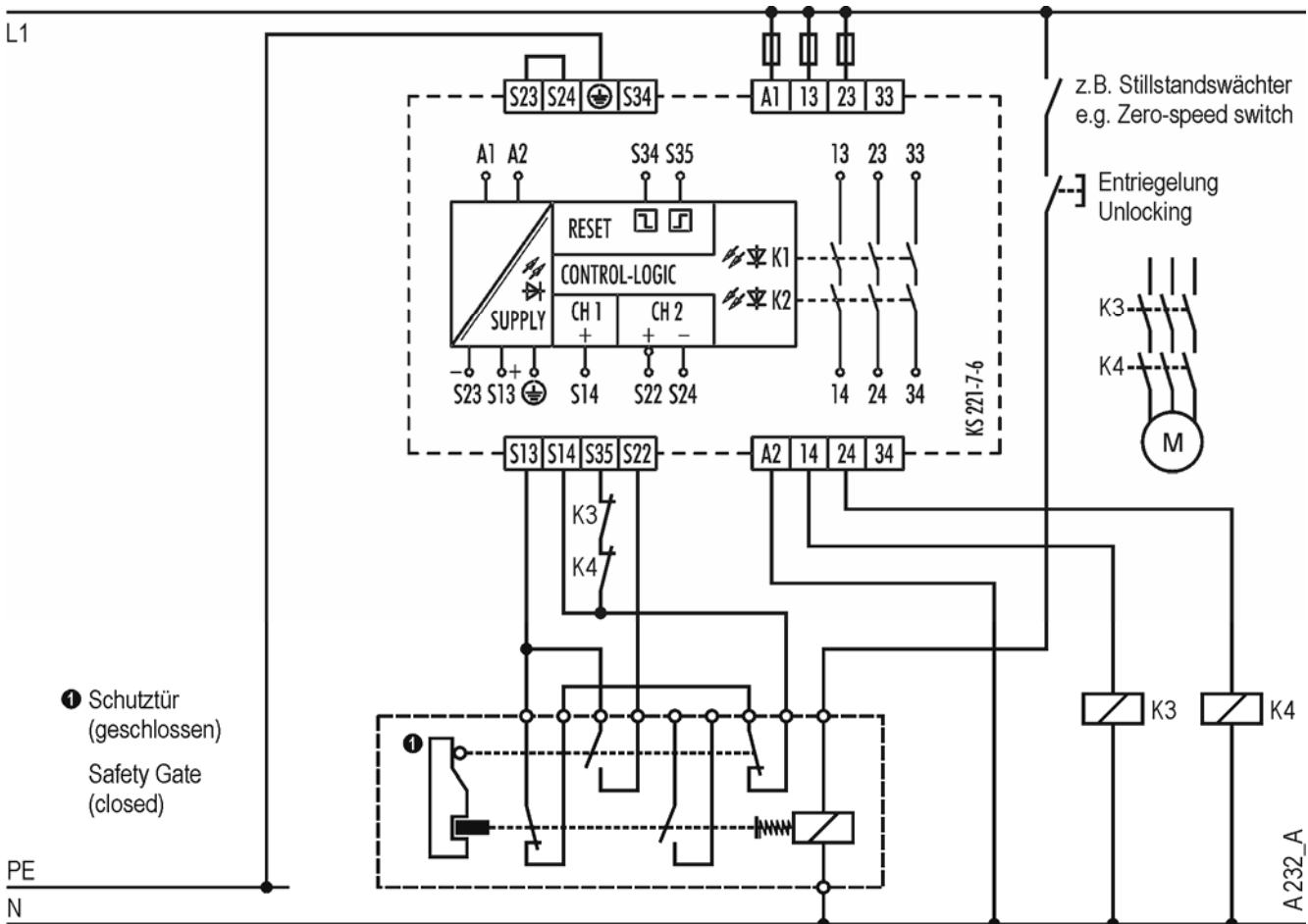

Two-channel safety gate monitoring with latching (cross monitoring) and automatic reset.

The position of the safety gate is monitored via channel 1 (S14) and channel 2 (S22). Channel 1 also monitors the position of the latching through a series connected NC contact. When the gate is closed, the latching is not actuated and the feedback circuit is closed (NC contacts K3, K4), all enabling current paths and the contactors K3, K4

automatically switch on. The safety gate can be opened once the standstill monitor contact is closed and the unlocking button has been actuated. The gate must be opened to carry out another automatic reset (channel 1 opens/closes, channel 2 closes/opens). The safety gate cannot be opened when the voltage supply is switched off and the latching is engaged. It is recommended to use switches with a mechanical unlocking option.

Two-Channel Safety Gate Monitor, Tumbler Activated by Magnetic Technology

Type of Device	SNV 4063KL	
Category	Application (acc. to EN 954-1)	3
	Stop category (acc. to EN 60204-1)	1
Application Features	<ul style="list-style-type: none"> • 2-channel monitor • cross monitoring • ground-fault detection • automatic reset • OFF-delay • monitoring of external contactors (EDM) 	
Safety Sensors	Position switch with tumbler Type LS-S02-...FT-ZBZ/X, Moeller	
Remarks/Notes	<p>(1) Fault exclusion "Cancel or release of the actuator, fault in safety locking mechanism".</p> <p>(2) Refer to the Section "Terms" for information on connecting position switches in series.</p>	

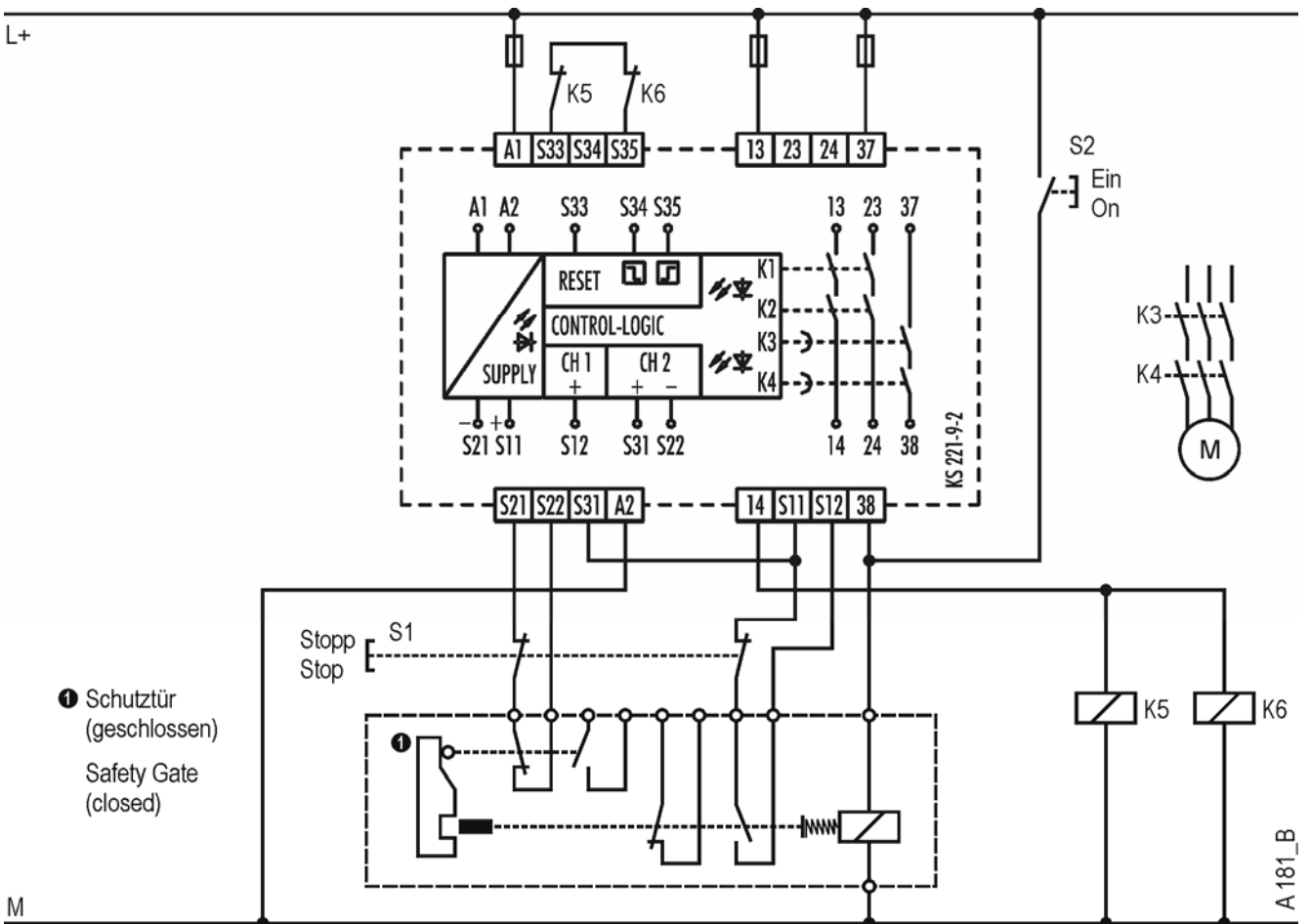

Two-channel safety gate monitoring with latching (cross monitoring) and automatic reset.

The position of the safety gate is monitored via channel 1 (S12) and the latching via channel 2 (S22). When the gate and the feedback circuit (NC contacts K5, K6) are both closed, the ON-button S2 is activated and all enabling current paths as well as the contactors K5, K6 switch on immediately. Issuing the stop command via S1 immediately

causes contactors the K5, K6 to switch off. After the set OFF-delay has elapsed, the tumbler magnet is demagnetized and the safety gate can be opened. The safety gate is immediately enabled when the voltage supply is switched off. With two-channel monitoring both channels must be opened and closed in parallel before the safety gate can be once again enabled.

Two-Channel Safety Gate Monitor, Tumbler Activated by Spring Technology

Type of Device	SNV 4063KP	
Category	Application (acc. to EN 954-1)	3
	Stop category (acc. to EN 60204-1)	1
Application Features	<ul style="list-style-type: none"> • 2-channel monitor • cross monitoring • ground-fault detection • manual, monitored reset • ON-delay • monitoring of external contactors (EDM) 	
Safety Sensors	Position switch with tumbler Type LS-S02-...FT-ZBZ/X, Moeller	
Remarks/Notes	<p>(1) Fault exclusion "Cancel or release of the actuator, fault in safety locking mechanism".</p> <p>(2) Refer to the Section "Terms" for information on connecting position switches in series.</p>	

2

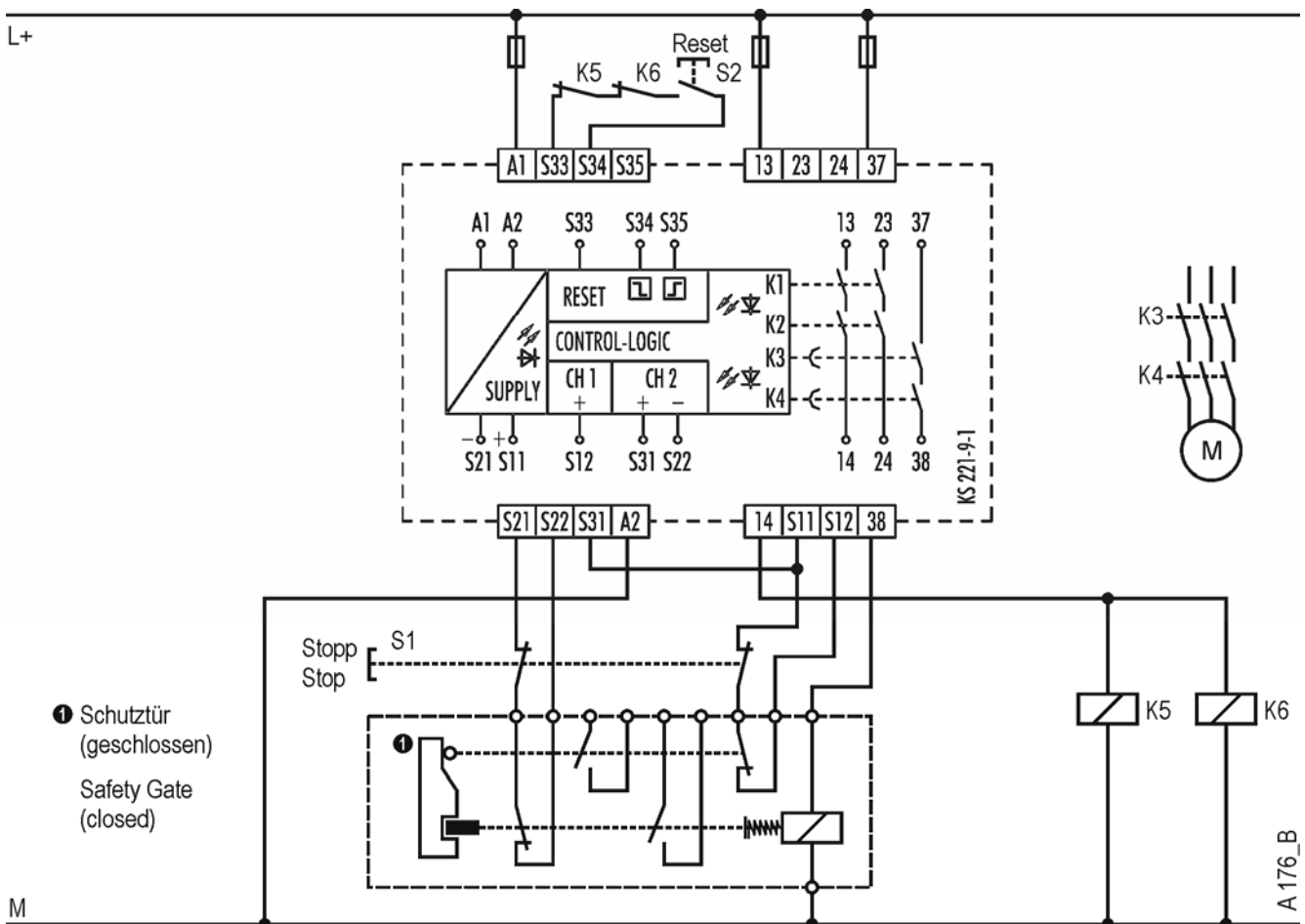

Two-channel safety gate monitoring with latching (cross monitoring) and manual, monitored reset.

The position of the safety gate is monitored via channel 1 (S12) and the latching via channel 2 (S22). After the supply voltage is applied to A1/A2, the enabling current path 37/38 is closed after the ON-delay has elapsed; in the process, the tumbler is unlocked as well. When both the door and the feedback circuit (NC contacts K5, K6) are closed, the reset button S2 is activated and the enabling current paths 13/14, 23/24 and the contactors K5, K6 switch on immediately. The enabling current path 37/38 opens and locks the door. Issuing the stop command via S1

immediately causes the contactors K5, K6 to switch off. After the set ON-delay has elapsed, the spring-technology-activated tumbler is actuated via the enabling current path 37/38. The safety gate cannot be opened when the voltage supply is switched off and the latching is engaged. Switching off the voltage does not disable the ON-delay; in other words, the gate is not automatically enabled to open. It is recommended to use switches with a mechanical unlocking option. With two-channel monitoring both channels must be opened and closed in parallel before the safety gate can be once again enabled.

Robot Monitors, Emergency Stop and Safety Gate Monitors, and Access Protection with Light Curtain

Type of Device	SA-BM-S1 / SA-IN-S1
Category	Application (acc. to EN 954-1) Stop category (acc. to EN 60204-1)
Application Features	<ul style="list-style-type: none"> • 2-channel monitor • cross monitoring using the light curtains • ground-fault detection • manual, monitored reset • OFF-delay • monitoring of external contactors (EDM) • self test of OSSD
Safety Sensors	ESPE type 4 (semiconductor), emergency stop button, position switches, inductive sensor
Remarks/Notes	(1) OSSD has high level when the switch is in "OK" position. (2) <i>samos</i> modules and contactors in the same enclosure.

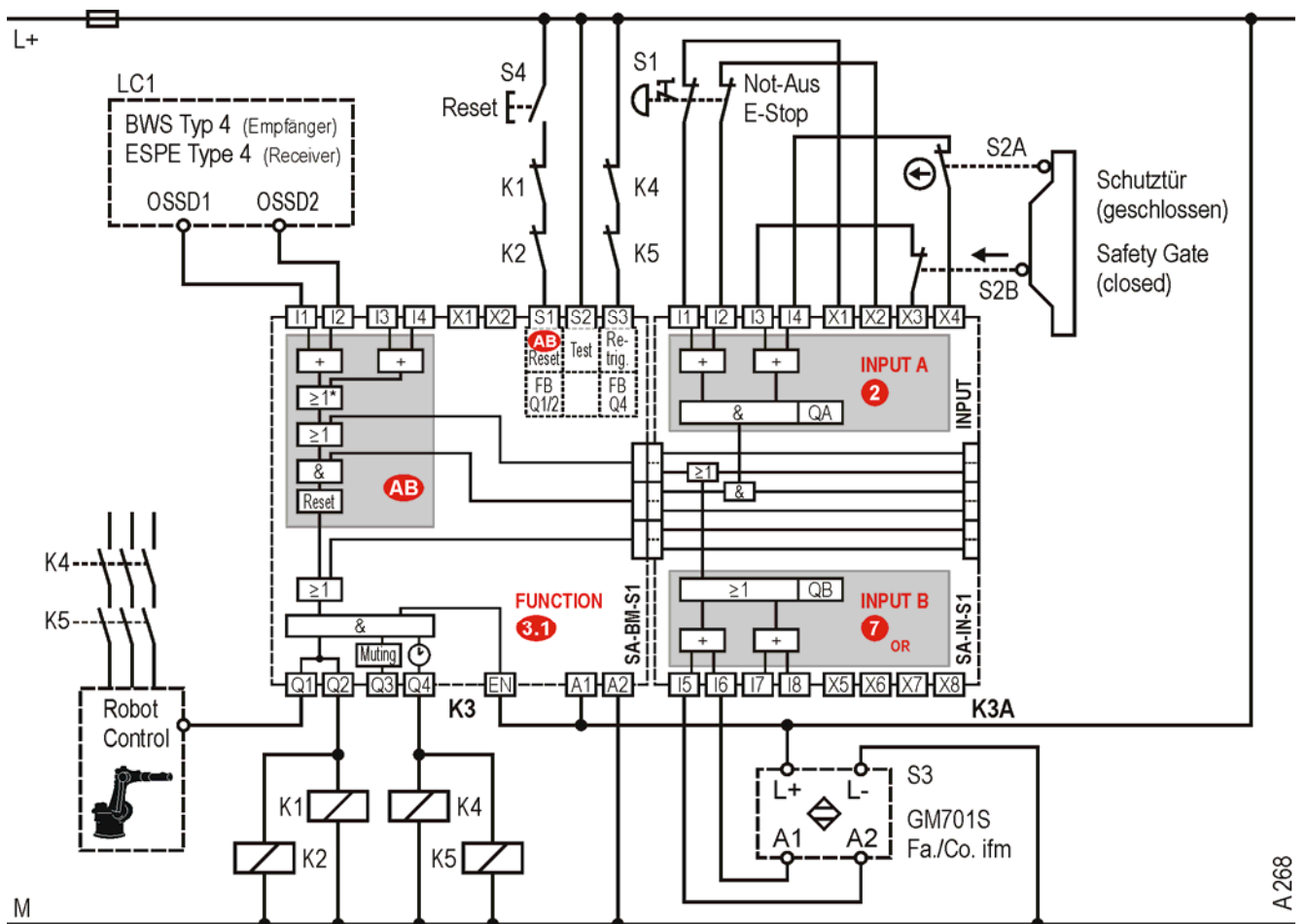

Robot monitors, emergency stop and safety gate monitors.

Robot zone access is monitored by the light curtain LC1. The machine zone is further protected by a safety gate and an emergency stop circuit. Sensor S3 is OR-linked with the light curtain LC1 and detects the safe position of the robot. This enables e.g. equipping through an opening in the processing area without switching off the robot power supply. If the robot is not in the safe position when the light curtain is interrupted, the entire machine and the

robot are switched off. Opening the safety gate or actuating the emergency stop button also result in a safe switch-off. The robot control receives the command to switch off (returning to the safe position) from Q1. K1 and K2 immediately interrupt the power supply to other consumers. The robot power supply is switched off safely via K4 and K5 after 1 s. Restart is possible after exiting the danger zone and pushing the reset button S4.

Bypassing Safety Gate Monitor for Setup via Key Lock Switch

Type of Device	SA-BM-S1	
Category	Application (acc. to EN 954-1)	4
	Stop category (acc. to EN 60204-1)	1
Application Features	<ul style="list-style-type: none"> • 2-channel monitor • cross monitoring • ground-fault detection • automatic reset • OFF-delay with retriggering function • monitoring of external contactors (EDM) 	
Safety Sensors	Position switches, key lock switch	
Remarks/Notes	<p>(1) Refer to the Section "Terms" for information on connecting position switches in series.</p> <p>(2) <i>samos</i> modules and contactors in the same enclosure.</p>	

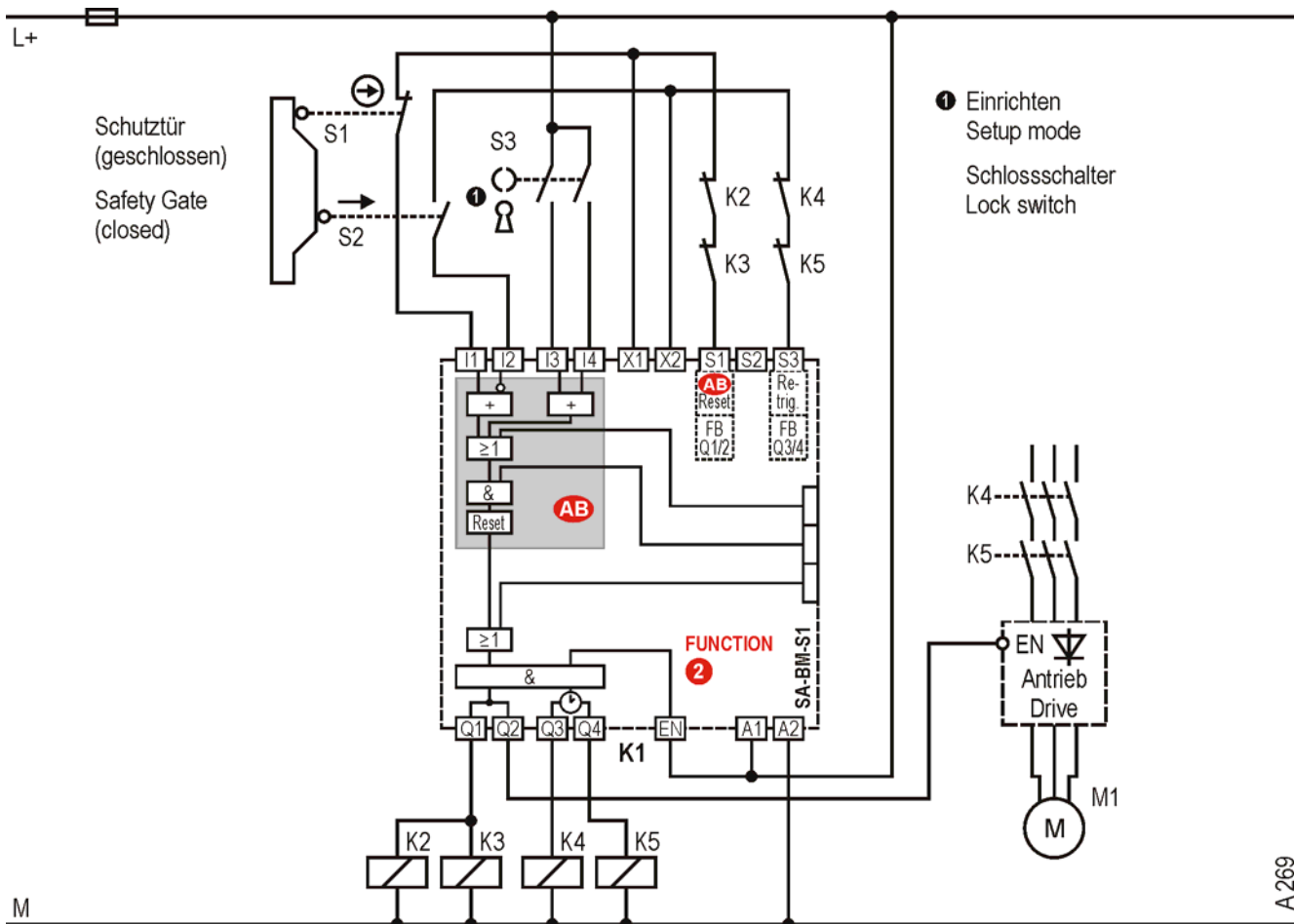

Bypassing safety gate monitoring for setup.

In automatic operation the key lock switch is not actuated and the safety door is monitored by S1 and S2. When the safety gate is closed, the monitoring contact of S1 is closed while the monitoring contact of S2 is open. When the gate is opened, the drive receives a stop signal from Q2. After the set OFF-delay has elapsed, K4 and K5 redundantly separate the drive from the power supply.

If the gate is closed before the OFF-delay time has elapsed, K4 and K5 do not interrupt the drive, since the "retriggering ON" function has been set via S3. This enables the production process to continue without major delays. Safety gate monitoring can be bypassed for setup using key lock switch S3. Reset is carried out automatically after power on and after safety events.

Two-Channel Safety Gate Monitor

Type of Device	SNA 4043K (all voltage versions)	
Category	Application (acc. to EN 954-1)	4
	Stop category (acc. to EN 60204-1)	0
Application Features	<ul style="list-style-type: none"> • 2-channel monitor • cross monitoring • ground-fault detection • automatic reset • monitoring of external contactors (EDM) • no synchrocheck available 	
Safety Sensors	Position switches	
Remarks/Notes	Refer to the Section "Terms" for information on connecting position switches in series.	

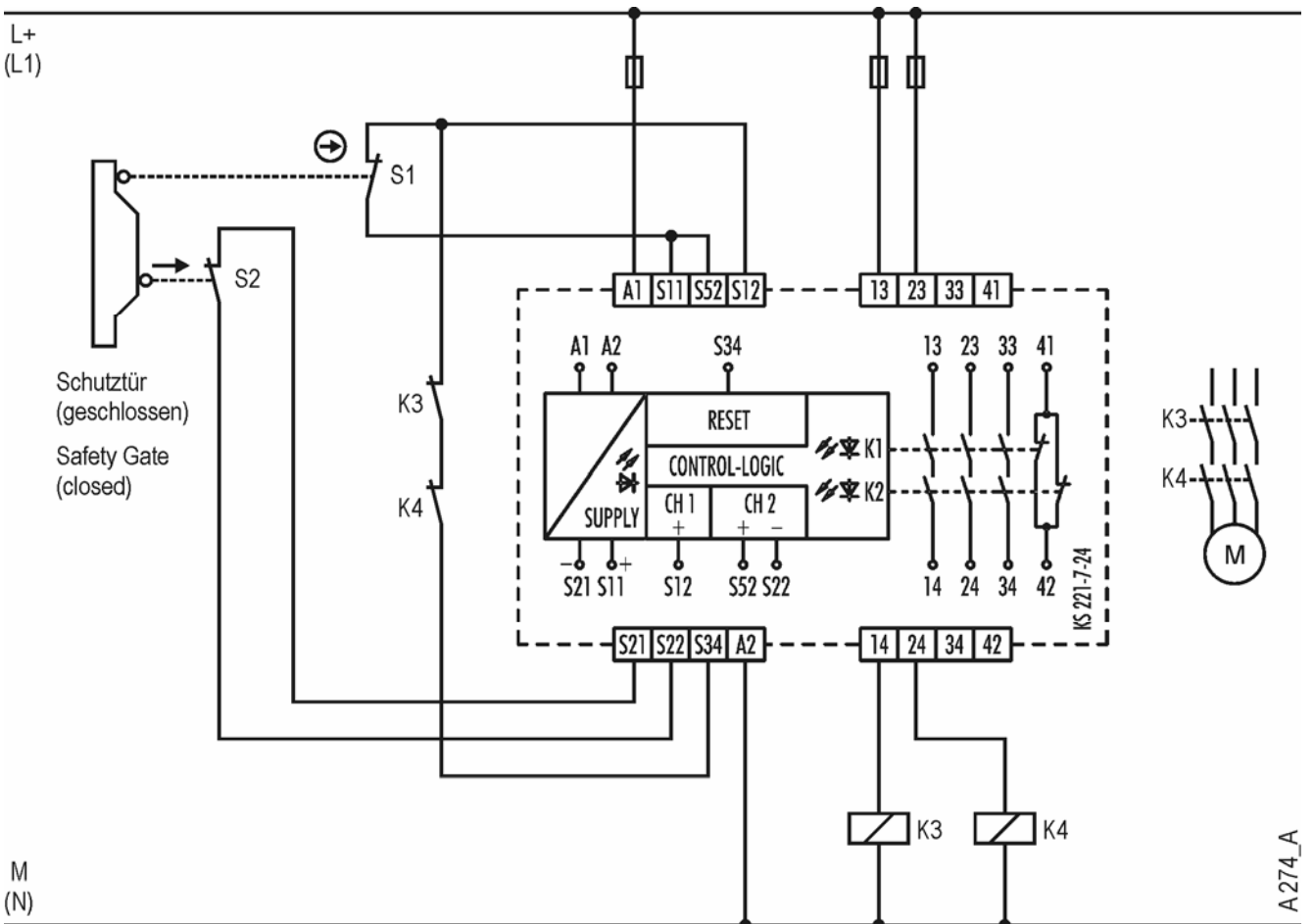

Two-channel safety gate monitoring (cross monitoring) with automatic reset.

The safety switching device and the contactors K3, K4 are switched on when the NC contact of position switch S1, the NO contact of position switch S2 and the feedback circuit (NC contacts K3, K4) are closed. If one of the contacts of either position switch is opened, the safety switching device and the contactors K3, K4 are switched off.

A failure of one of the position switches or a crossover in their supply lines does not lead to a failure of the safety gate monitoring. The problem is detected before the next switching on process.

Two-Channel Safety Gate Monitor

Type of Device	SNO 4062K	
Category	Application (acc. to EN 954-1)	4
	Stop category (acc. to EN 60204-1)	0
Application Features	<ul style="list-style-type: none"> • 2-channel monitor • cross monitoring • automatic reset • synchrocheck • monitoring of external contactors (EDM) 	
Safety Sensors	Position switches	
Remarks/Notes	<p>(1) Refer to the Section "Terms" for information on connecting position switches in series.</p> <p>(2) Synchronous monitoring time t_s: Closing sequence S1 before S2: $t_s = 0,5\text{ s}$ S2 before S1: $t_s = \infty$</p>	

2

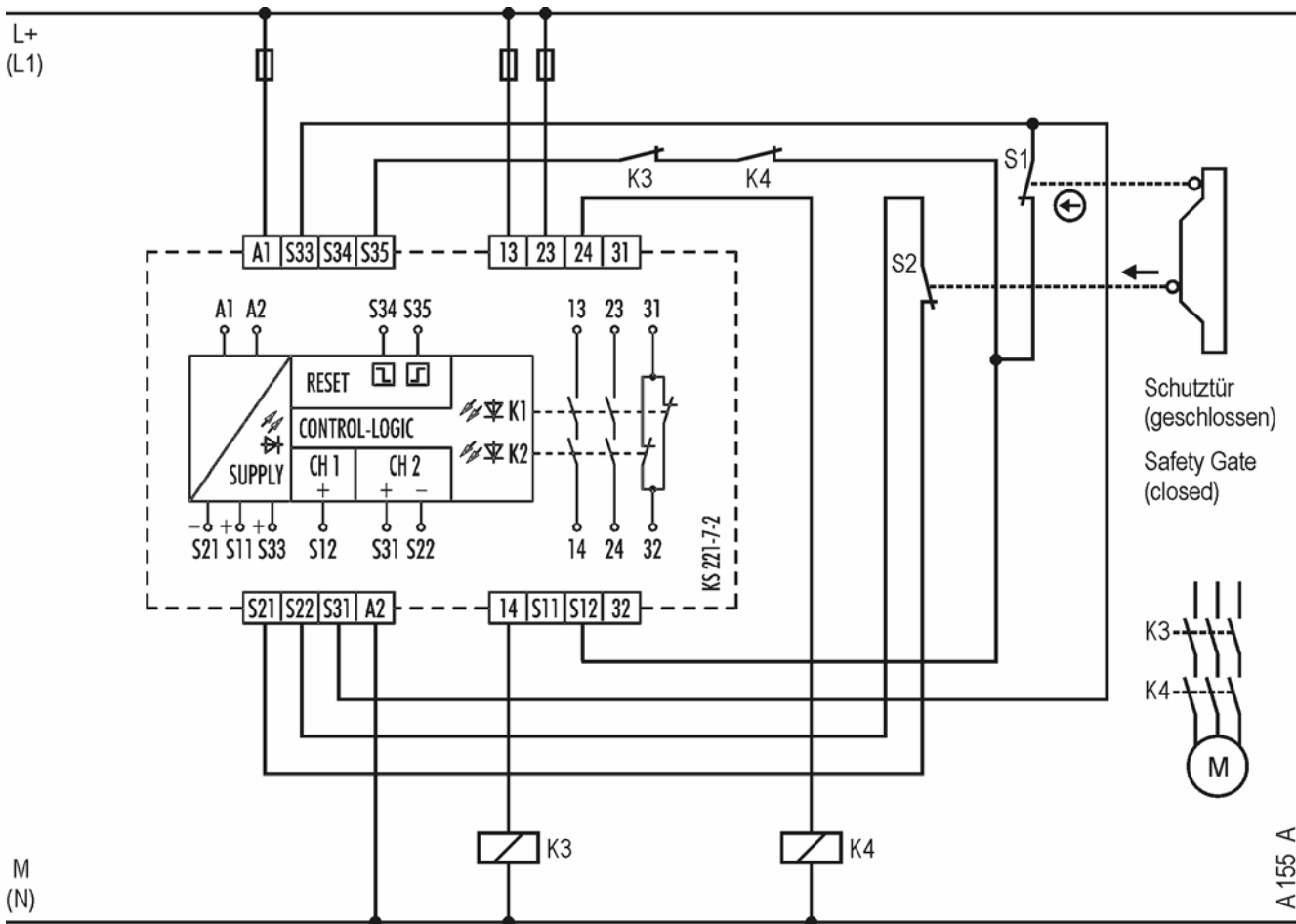

Two-channel safety gate monitoring (cross monitoring) with automatic reset.

The safety switching device and the contactors K3, K4 are switched on when the NC contact of position switch S1, the NO contact of position switch S2 and the feedback circuit (NC contacts K3, K4) are closed. If one of the contacts of either position switch is opened, the safety switching device and the contactors K3, K4 are switched off.

A failure of one of the position switches or a crossover in their supply lines does not lead to a failure of the safety gate monitoring. The problem is detected before the next switching on process.

Two-Channel Safety Gate Monitor

Type of Device	SNO 4062K
Category	Application (acc. to EN 954-1) Stop category (acc. to EN 60204-1)
Application Features	<ul style="list-style-type: none"> • 2-channel monitor • cross monitoring using the switches • ground-fault detection • automatic reset • monitoring of external contactors (EDM) • self test of command device • OSSD compatible
Safety Sensors	Electronic position switches, type LSE11, Moeller
Remarks/Notes	<p>(1) Refer to the Section "Terms" for information on connecting position switches in series.</p> <p>(2) OSSD has high level when the switch is in "OK" position.</p>

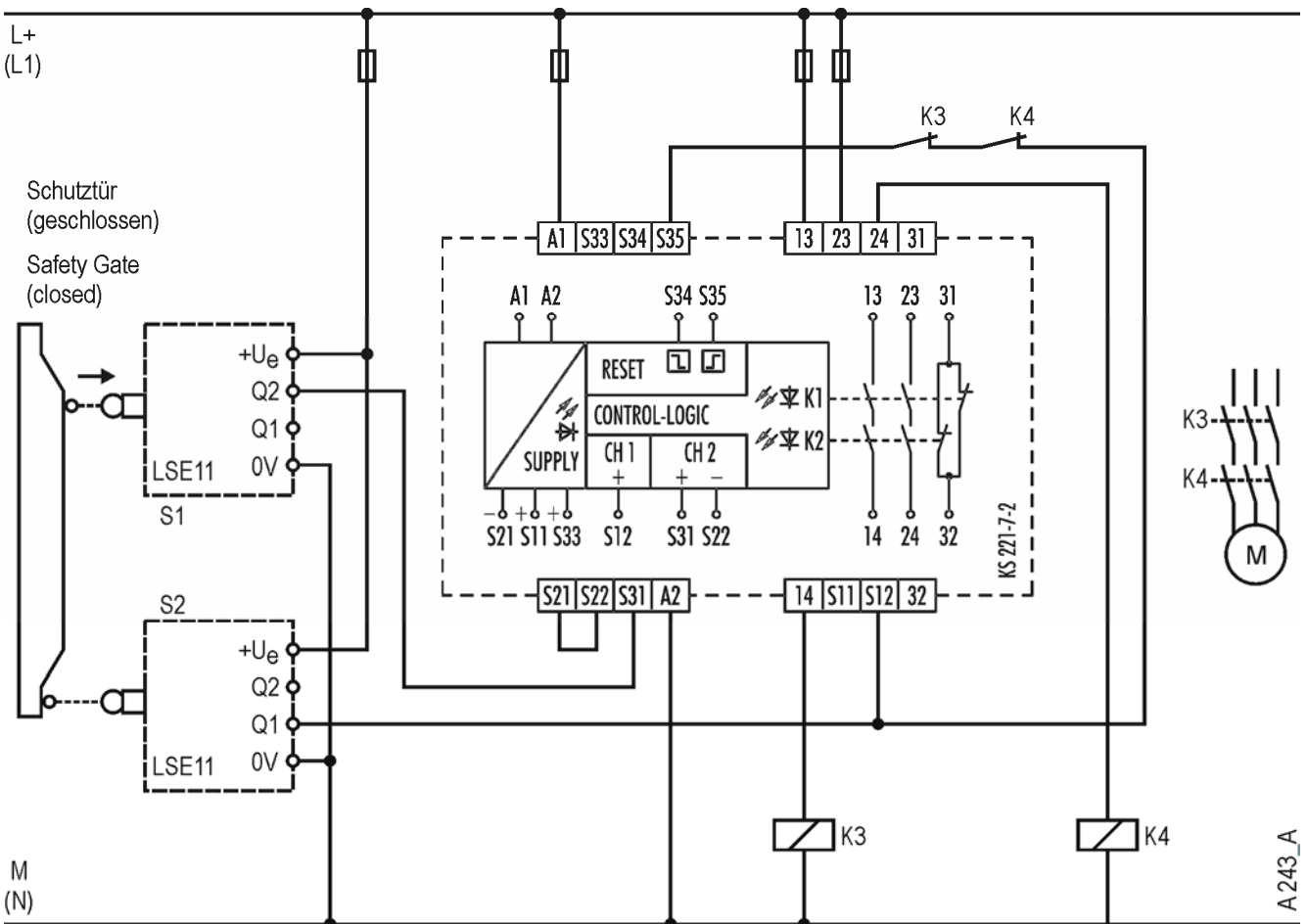

Two-channel safety gate monitoring (cross monitoring) with automatic reset.

The safety switching device and the contactors K3, K4 are switched on when the output Q2 of the actuated position switch S1 and the output Q1 of the non-actuated position switch S2 both issue a HIGH signal and the feedback circuit (NC contacts K3, K4) is closed. If either one or both of the outputs Q1 or Q2 of the position switch issue a

LOW signal, the safety switching device and the contactors K3, K4 switch off.

A failure of one of the position switches or a crossover in their supply lines does not lead to a failure of the safety gate monitoring. The problem is detected before the next switching on process.

Two-Channel Safety Gate Monitor

Type of Device	SNO 4063K (AC 230 V)	
Category	Application (acc. to EN 954-1)	4
	Stop category (acc. to EN 60204-1)	0
Application Features	<ul style="list-style-type: none"> • 2-channel monitor • cross monitoring • ground-fault detection • automatic reset • monitoring of external contactors (EDM) • synchrocheck 	
Safety Sensors	Position switches	
Remarks/Notes	<p>(1) Refer to the Section "Terms" for information on connecting position switches in series.</p> <p>(2) Synchronous monitoring time t_s: Closing sequence S1 before S2: $t_s = 0,5\text{ s}$ S2 before S1: $t_s = \infty$</p>	

2

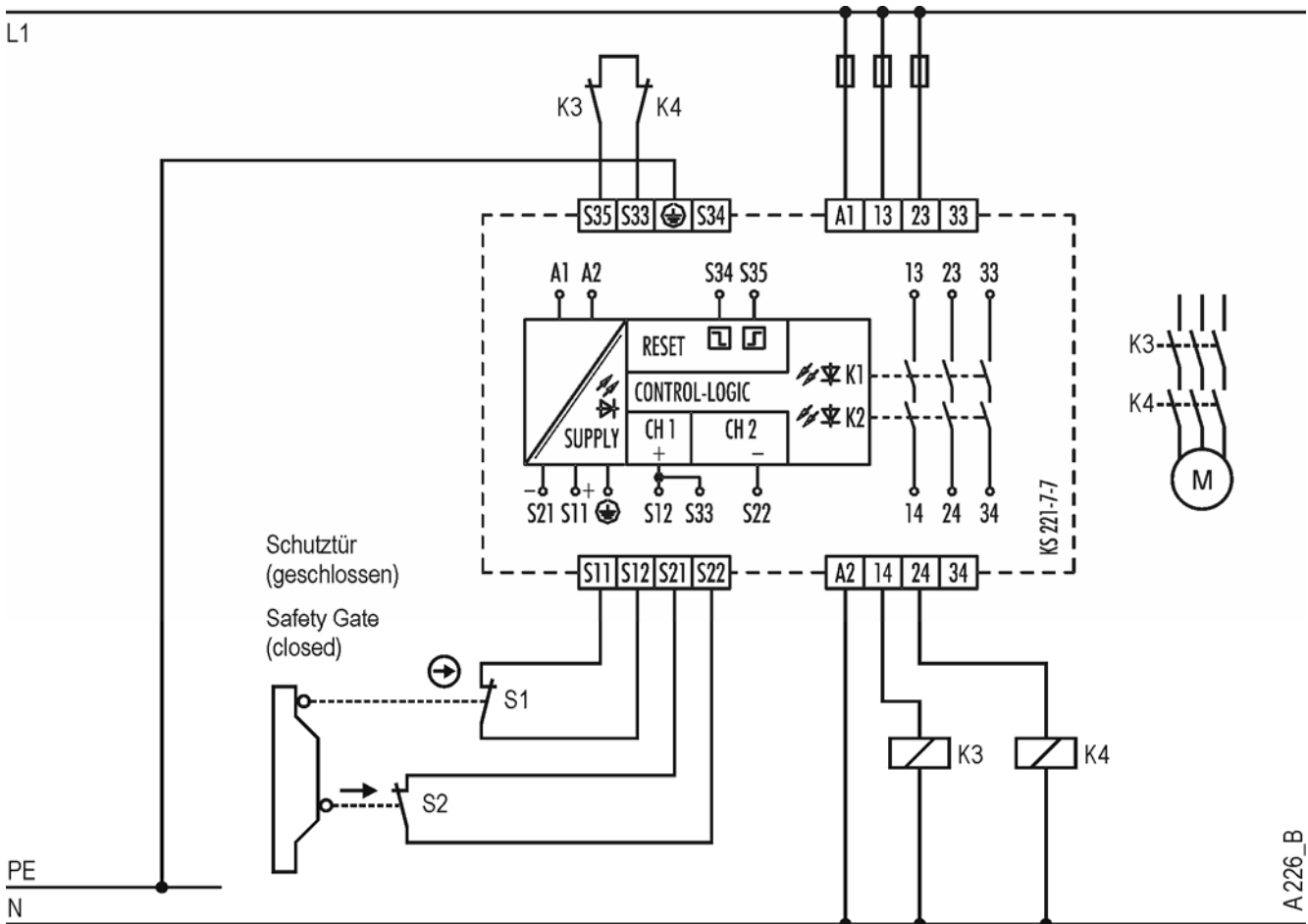

Two-channel safety gate monitoring (cross monitoring) with automatic reset.

The safety switching device and the contactors K3, K4 are switched on when the NC contact of position switch S1, the NO contact of position switch S2 and the feedback circuit (NC contacts K3, K4) are closed. If one of the contacts of either position switch is opened, the safety switching device and the contactors K3, K4 are switched off.

A failure of one of the position switches or a crossover in their supply lines does not lead to a failure of the safety gate monitoring. The problem is detected before the next switching on process.

Two-Channel Safety Gate Monitor

Type of Device	SNO 4063K (AC/DC 24 V)	
Category	Application (acc. to EN 954-1)	4
	Stop category (acc. to EN 60204-1)	0
Application Features	<ul style="list-style-type: none"> • 2-channel monitor • cross monitoring using the switches • ground-fault detection • automatic reset • monitoring of external contactors (EDM) • self test of command device • OSSD compatible 	
Safety Sensors	Electronic position switches, type LSE11, Moeller	
Remarks/Notes	(1) Refer to the Section "Terms" for information on connecting position switches in series. (2) OSSD has high level when the switch is in "OK" position.	

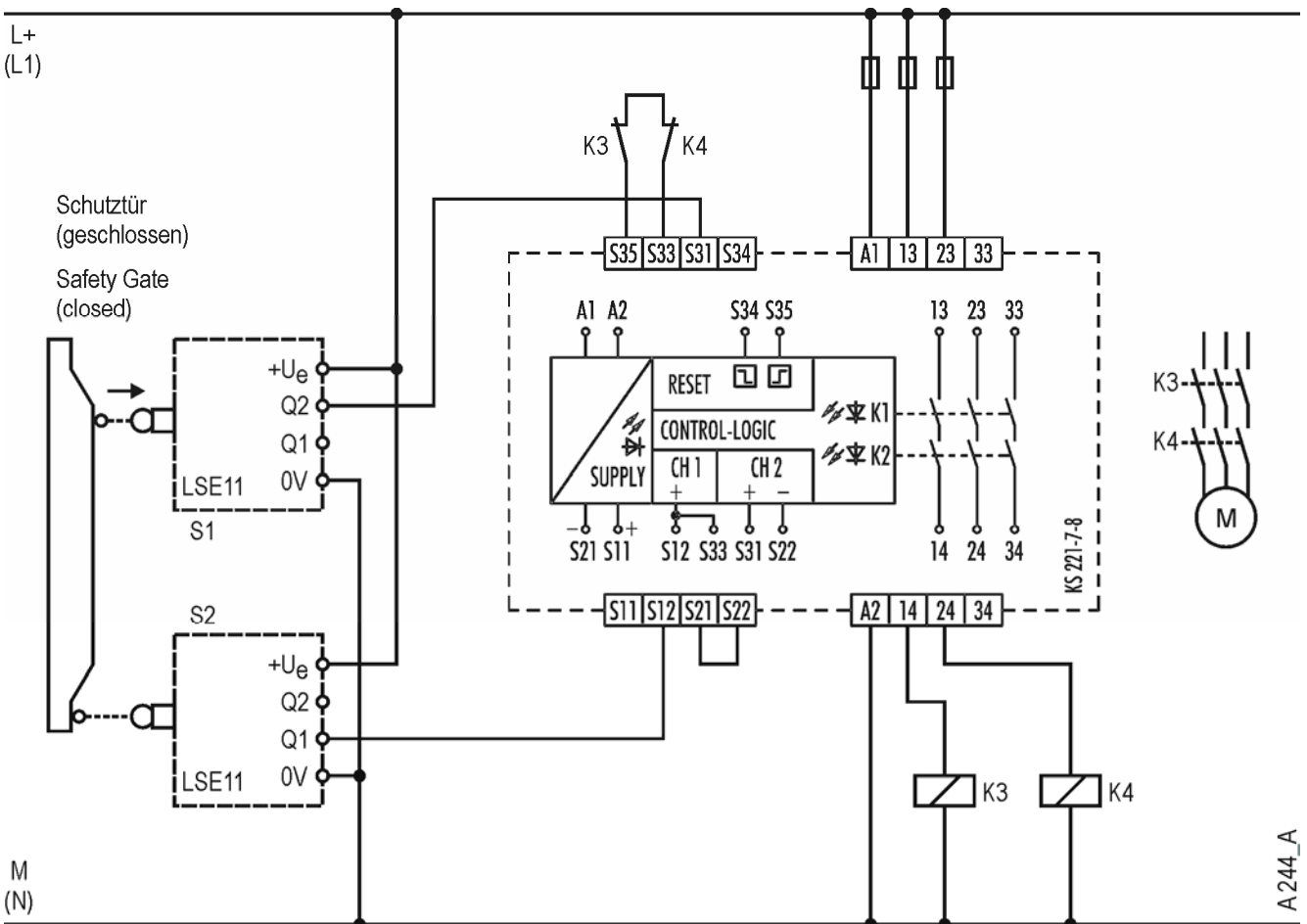

Two-channel safety gate monitoring (cross monitoring) with automatic reset.

The safety switching device and the contactors K3, K4 are switched on when the output Q2 of the actuated position switch S1 and the output Q1 of the non-actuated position switch S2 both issue a HIGH signal and the feedback circuit (NC contacts K3, K4) is closed. If either one or both of the outputs Q1 or Q2 of the position switch issue a

LOW signal, the safety switching device and the contactors K3, K4 switch off.

A failure of one of the position switches or a crossover in their supply lines does not lead to a failure of the safety gate monitoring. The problem is detected before the next switching on process.

Two-Channel Safety Gate Monitor

Type of Device	SNT 4M63K (AC/DC 24 V)	
Category	Application (acc. to EN 954-1)	4
	Stop category (acc. to EN 60204-1)	0
Application Features	<ul style="list-style-type: none"> • 2-channel monitor • cross monitoring • ground-fault detection • automatic reset • synchrocheck • monitoring of external contactors (EDM) 	
Safety Sensors	Position switches	
Remarks/Notes	<p>(1) Automatic reset only occurs when both position switches are actuated.</p> <p>(2) Refer to the Section "Terms" for information on connecting position switches in series.</p> <p>(3) Synchronous monitoring time t_s: Closing sequence S1 before S2: $t_s = 0,5\text{ s}$ S2 before S1: $t_s = \infty$</p>	

2

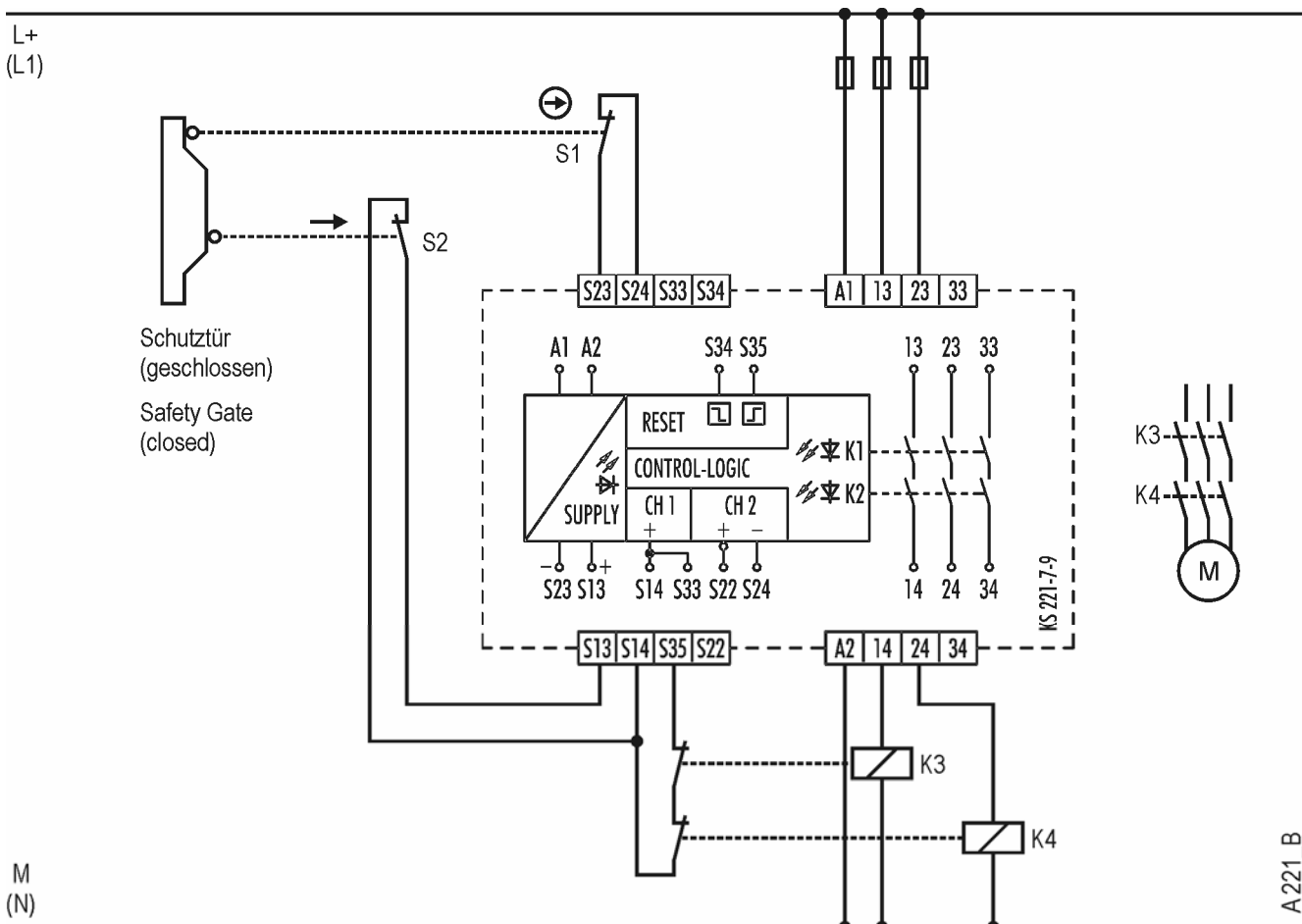

Two-channel safety gate monitoring (cross monitoring) with automatic reset.

The safety switching device and the contactors K3, K4 are switched on when the NC contact of position switch S1, the NO contact of position switch S2 and the feedback circuit (NC contacts K3, K4) are closed. If one of the contacts of either position switch is opened, the safety

switching device and the contactors K3, K4 are switched off.

A failure of one of the position switches or a crossover in their supply lines does not lead to a failure of the safety gate monitoring. The problem is detected before the next switching on process.

Two-Channel Safety Gate Monitor

Type of Device	SNT 4M63K (AC/DC 24 V)	
Category	Application (acc. to EN 954-1)	4
	Stop category (acc. to EN 60204-1)	0
Application Features	<ul style="list-style-type: none"> • 2-channel monitor • cross monitoring • ground-fault detection • automatic reset • synchrocheck • monitoring of external contactors (EDM) 	
Safety Sensors	Position switches	
Remarks/Notes	<p>(1) Automatic reset only occurs when both position switches are actuated.</p> <p>(2) Refer to the Section "Terms" for information on connecting position switches in series.</p> <p>(3) Synchronous monitoring time t_s: Closing sequence S1 before S2: $t_s = 0,5\text{ s}$ S2 before S1: $t_s = \infty$</p>	

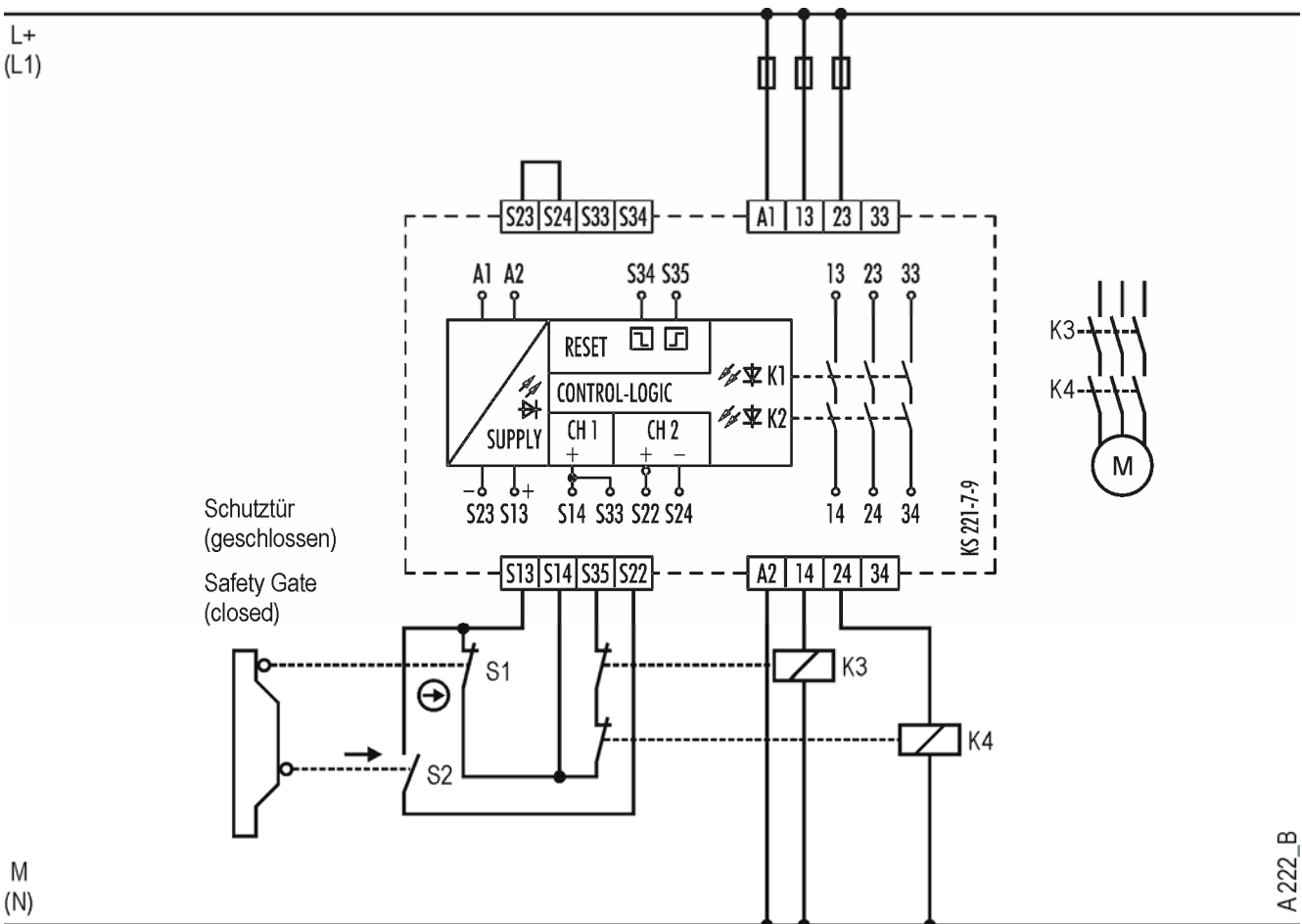

Two-channel safety gate monitoring (cross monitoring) with automatic reset.

The safety switching device and the contactors K3, K4 are switched on when the NC contact of position switch S1 is closed, the NC contact of position switch S2 is open and the feedback circuit (NC contacts K3, K4) is closed. If the NC contact of position switch 1 is open and/or the

NC contact of position switch S2 is closed, the safety switching device and the NC contactors K3, K4 are switched off.

A failure of one of the position switches or a crossover in their supply lines does not lead to a failure of the safety gate monitoring. The problem is detected before the next switching on process.

Two-Channel Safety Gate Monitor with Magnetic Switch

Type of Device	SNT 4M63K (AC/DC 24 V)	
Category	Application (acc. to EN 954-1)	4
	Stop category (acc. to EN 60204-1)	0
Application Features	<ul style="list-style-type: none"> • 2-channel monitor PDF-M (acc. to EN 60947-5-3) • cross monitoring • ground-fault detection • automatic reset • monitoring of external contactors (EDM) 	
Safety Sensors	Magnetic switch with coded magnet	
Remarks/Notes	Refer to the Section "Terms" for information on connecting position switches in series.	

2

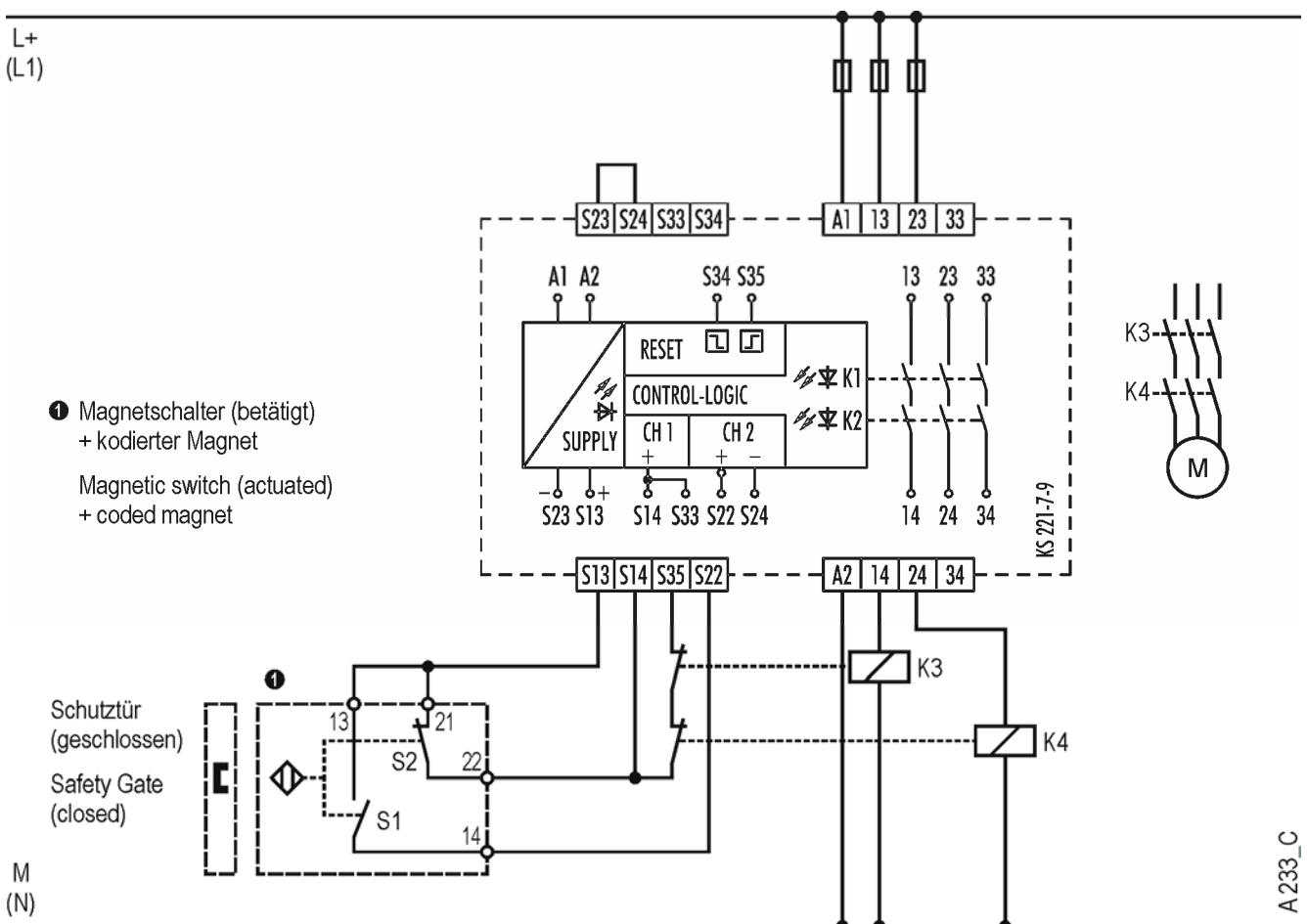

Two-channel safety gate monitoring (cross monitoring) with automatic reset.

The safety switching device and the contactors K3, K4 are switched on when the NC contact S2 of the magnetic switch is closed, the NO contact S1 of the magnetic switch is open and the feedback circuit (NC contacts K3, K4) is closed. If the NC contact S2 of the magnetic switch is opened and the NO contact S1 of the magnetic switch is closed, the safety switching device and the contactors K3, K4 are switched off.

A failure of one of the contacts of the magnetic switch or a crossover in its supply lines does not lead to a failure of the safety gate monitoring. The problem is detected before the next switching on process.

Two-Channel Safety Gate Monitor with Magnetic Switch

Type of Device	SNT 4M63K (AC/DC 24 V)	
Category	Application (acc. to EN 954-1)	4
	Stop category (acc. to EN 60204-1)	0
Application Features	<ul style="list-style-type: none"> • 2-channel monitor PDF-M (acc. to EN 60947-5-3) • cross monitoring • ground-fault detection • manual, monitored reset • monitoring of external contactors (EDM) 	
Safety Sensors	Magnetic switch with coded magnet	
Remarks/Notes	Refer to the Section "Terms" for information on connecting position switches in series.	

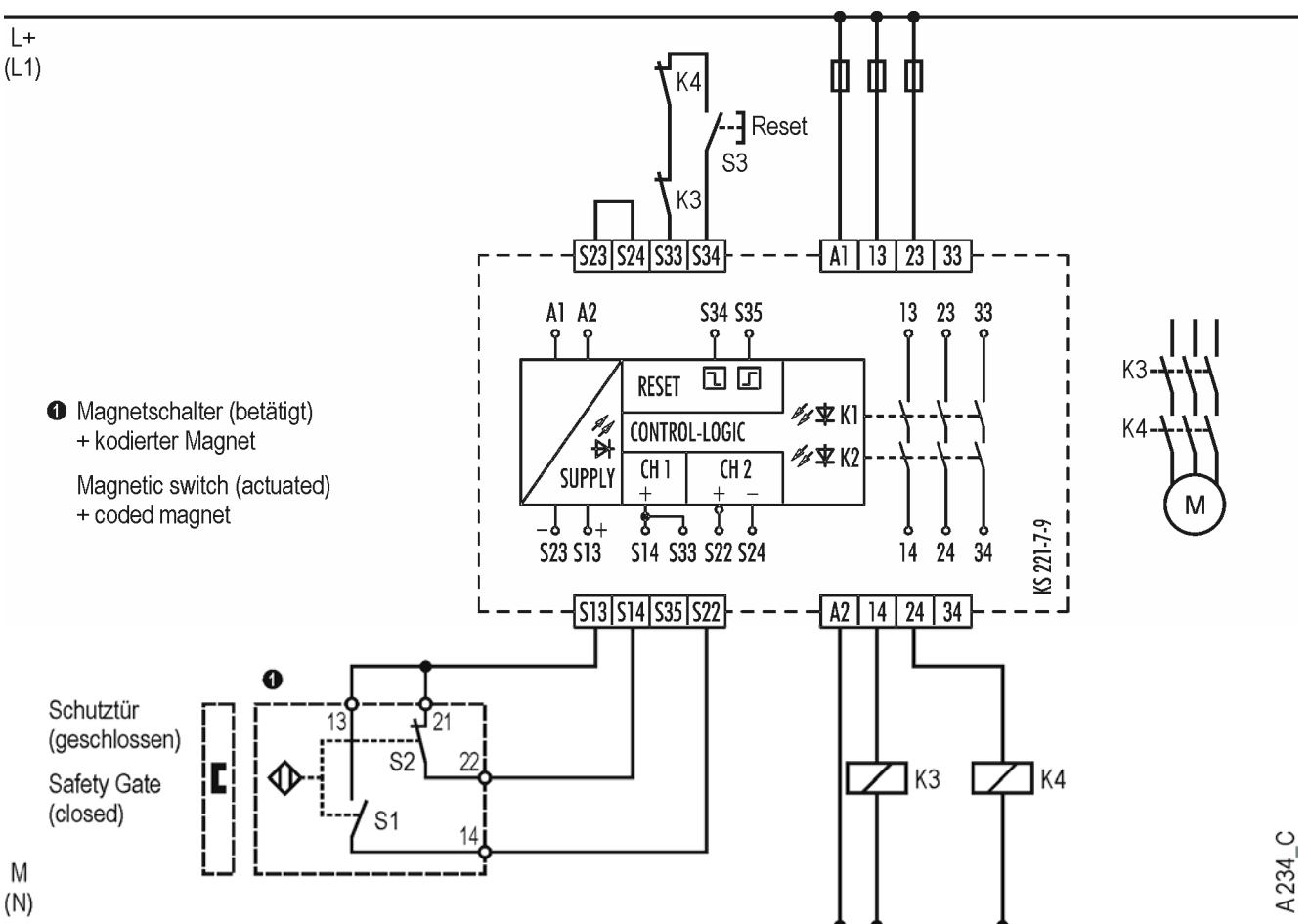

Two-channel safety gate monitoring (cross monitoring) with manual, monitored reset.

The safety switching device and the contactors K3, K4 are switched on when the NC contact S2 of the magnetic switch is closed, the NO contact S1 of the magnetic switch is open and the feedback circuit (NC contacts K3, K4) is closed. If the NC contact S2 of the magnetic switch is opened and the NO contact S1 of the magnetic switch is closed, the safety switching device and the contactors K3, K4 are switched off.

A failure of one of the contacts of the magnetic switch or a crossover in its supply lines does not lead to a failure of the safety gate monitoring. The problem is detected before the next switching on process.

Two-Channel Safety Gate Monitor, Controlled Stop

Type of Device	SNV 4063KL
Category	Application (acc. to EN 954-1) Stop category (acc. to EN 60204-1)
Application Features	<ul style="list-style-type: none"> • 2-channel monitor • cross monitoring, ground-fault detection • manual, monitored reset • OFF-delay • synchrocheck • monitoring of external contactors (EDM)
Safety Sensors	Position switches
Remarks/Notes	<p>(1) If the Safety devices are in the same control cabinet or protective wiring is used then 1-channel control of the contactors/expansion devices is acceptable.</p> <p>(2) Refer to the Section "Terms" for information on connecting position switches in series.</p> <p>(3) Synchronous monitoring time t_s: Closing sequence S1 before S2: $t_s = 0,5\text{ s}$ S2 before S1: $t_s = \infty$</p>

2

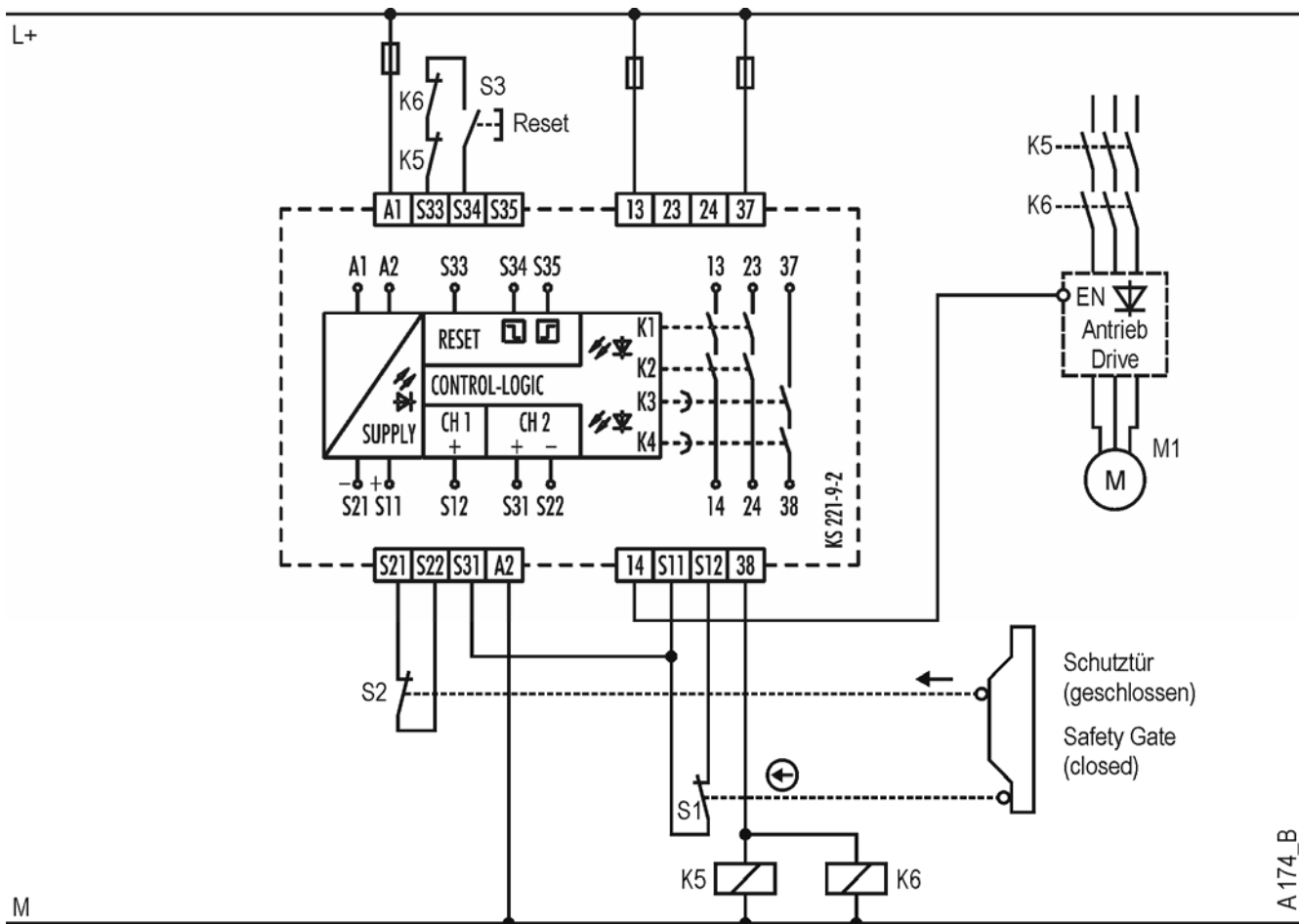

Two-channel safety gate monitoring (cross monitoring) with automatic reset.

The safety switching device and the contactors K5, K6 are switched on when the NC contact of position switch S1, the NO contact of position switch S2 and the feedback circuit (NC contact K3) are closed and the reset button is actuated and released again. If the NC contact of position switch S1 and/or the NO contact of position switch S2 are

opened, the drive control enabling input is switched off. After the OFF-delay time has elapsed, the contacts K5, K6 are switched off.

A failure of a position switch or a crossover in their supply lines does not lead to a failure of the safety gate monitoring. The problem is detected before the next switching on process.



3 Light Curtain

Cat-egory ¹⁾	Device	Safety sensors Features	Reset / start and restart inhibit	Stop category ²⁾	Applica-tion number	Page
2	SNL 4062K	ESPE type 2 (SC), emergency stop button	manual	0	A 241	3 • 2
3	<i>samos</i>	2 safety zones, emergency stop button, ESPE type 4 (SC)	manual, monitor	0	A 259	3 • 3
4	<i>samos</i>	ESPE type 4 (SC), muting sensors	manual, monitor	0	A 267	3 • 4
	<i>samos</i>	Emergency stop button, position switch, ESPE type 4 (SC), inductive sensor, OFF-delay	manual, monitor	1	A 268	2 • 15
	SNA 4064K	ESPE type 4 (SC)	manual, monitor	0	A 278	3 • 5
	SNE 4003K	ESPE type 4 (SC)	external	0	A 281	3 • 6
	SNO 4062K	ESPE type 4 (SC)	manual, monitor	0	A 229	3 • 7

¹⁾ acc. to EN 954-1 ²⁾ acc. to EN 60204-1

One-Channel Light Curtain Monitor (ESPE type 2) and Emergency Stop Monitor

Type of Device	SNL 4062K
Category	Application (acc. to EN 954-1) Stop category (acc. to EN 60204-1)
Application Features	<ul style="list-style-type: none"> • 1-channel monitor • ground-fault detection • manual reset • monitoring of external contactors (EDM)
Safety Sensors	ESPE type 2 (semiconductor)
Remarks/Notes	OSSD has high level when the switch is in "OK" position.

3

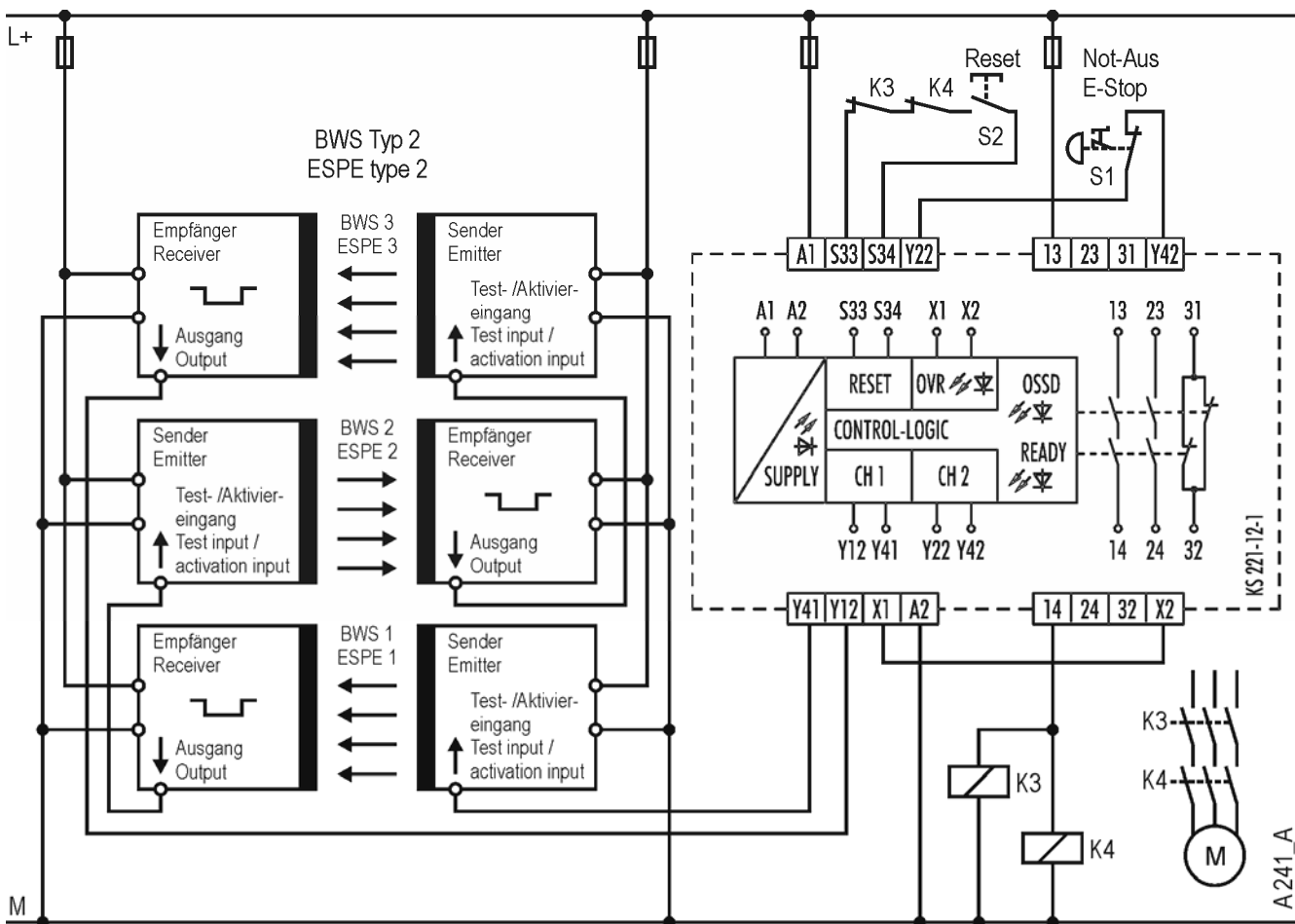

One-channel light curtain monitoring (ESPE type 2) and emergency stop monitoring with manual reset.

The safety switching device and the contactors K3, K4 are switched on when the emergency stop button is unlocked, the light barriers are uninterrupted, the feedback circuit (NC contacts K3, K4) is closed and the reset button is actuated. When one of the light barriers is interrupted or the emergency stop button is actuated, the safety relay and the contactors K3, K4 switch off.

The failure of one of the light barriers or a crossover either in their supply lines or of the emergency stop button does not lead to a failure in the safety functioning. The problem is detected before the next switching on process.

Caution: For the application depicted here, the function selector on the bottom of the device must be set as follows:

S1 = ON | S2 = OFF | S3 = ON

Two Safety Zones Monitor; Emergency Stop and Zone Monitor with Light Curtain; Output Expansion

Type of Device	SA-BM-S1 / SA-OR-S1
Category	Application (acc. to EN 954-1) 3 Stop category (acc. to EN 60204-1) 0
Application Features	<ul style="list-style-type: none"> • 2-channel monitor • cross monitoring using the light curtains • ground-fault detection • manual, monitored reset • monitoring of external contactors (EDM) • self test of OSSD
Safety Sensors	Emergency stop buttons, ESPE type 4 (semiconductor)
Remarks/Notes	(1) OSSD has high level when the switch is in "OK" position. (2) <i>samos</i> modules and contactors in the same enclosure.

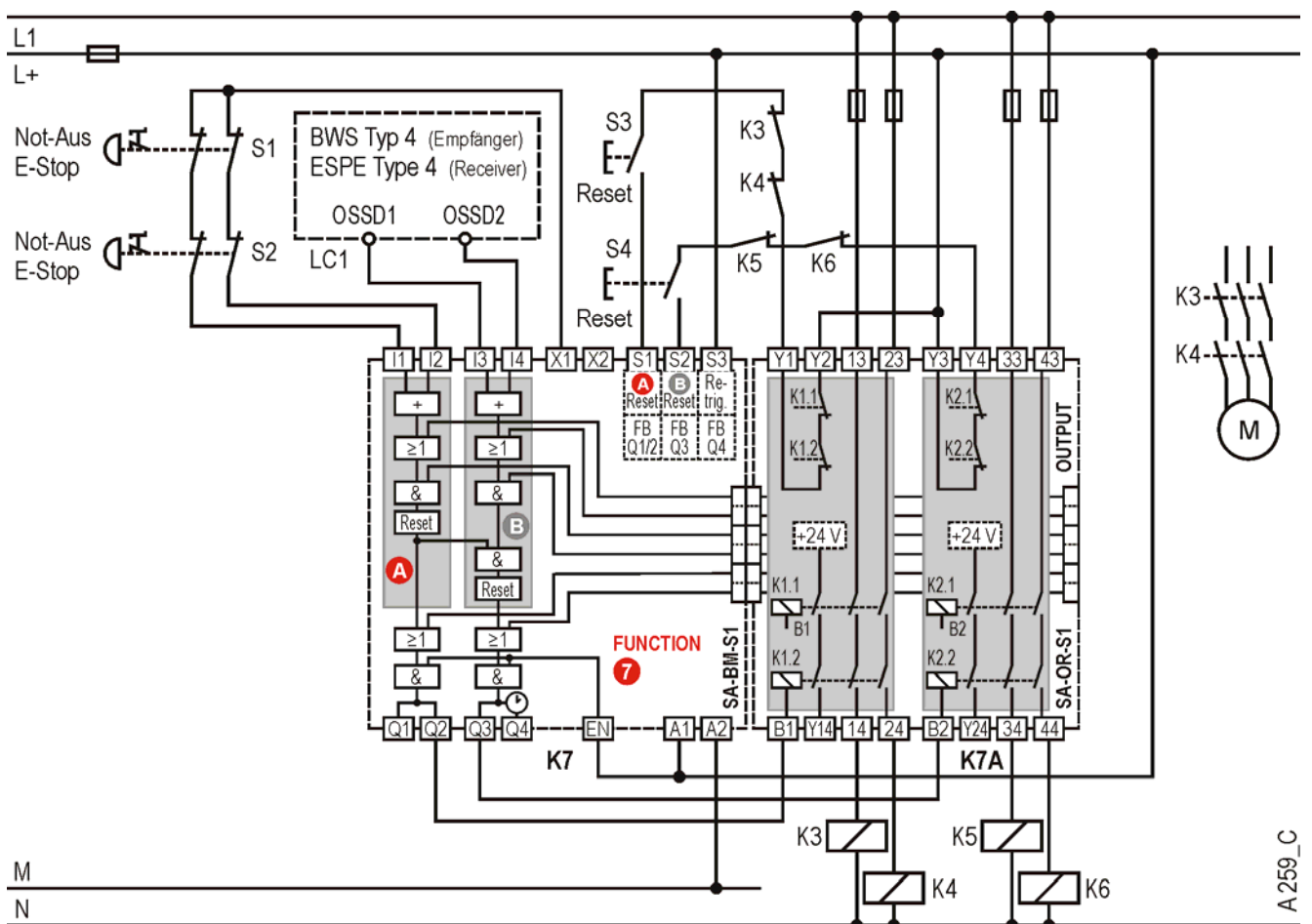

Two-channel emergency stop and zone monitoring with light curtain; emergency stop has priority over the light curtain function.

In case of emergency stop all contactors K3 to K6 switch off immediately. Start after emergency stop and after power on is with reset S3 and S4.

If light curtain LC1 (e.g. C4000, M4000, 30-FGS from Sick) is interrupted only K5 and K6 are switched off. After the light curtain is enabled and the feedback loop is successfully checked, group B can be reset via the reset S4.

Machine Zone Protection with Light Curtain and Muting Function

Type of Device	SA-BM-S1	
Category	Application (acc. to EN 954-1)	4
	Stop category (acc. to EN 60204-1)	0
Application Features	<ul style="list-style-type: none"> • 2-channel monitor • cross monitoring using the light curtains • ground-fault detection • manual, monitored reset • monitoring of external contactors (EDM) • self test of OSSD 	
Safety Sensors	ESPE type 4 (semiconductor, type C4000, Sick), muting sensors (semiconductor, type WS12, Sick)	
Remarks/Notes	<p>(1) Positive-switching muting sensors</p> <p>(2) OSSD has high level when the switch is in "OK" position.</p> <p>(3) <i>samos</i> modules and contactors in the same enclosure.</p>	

3

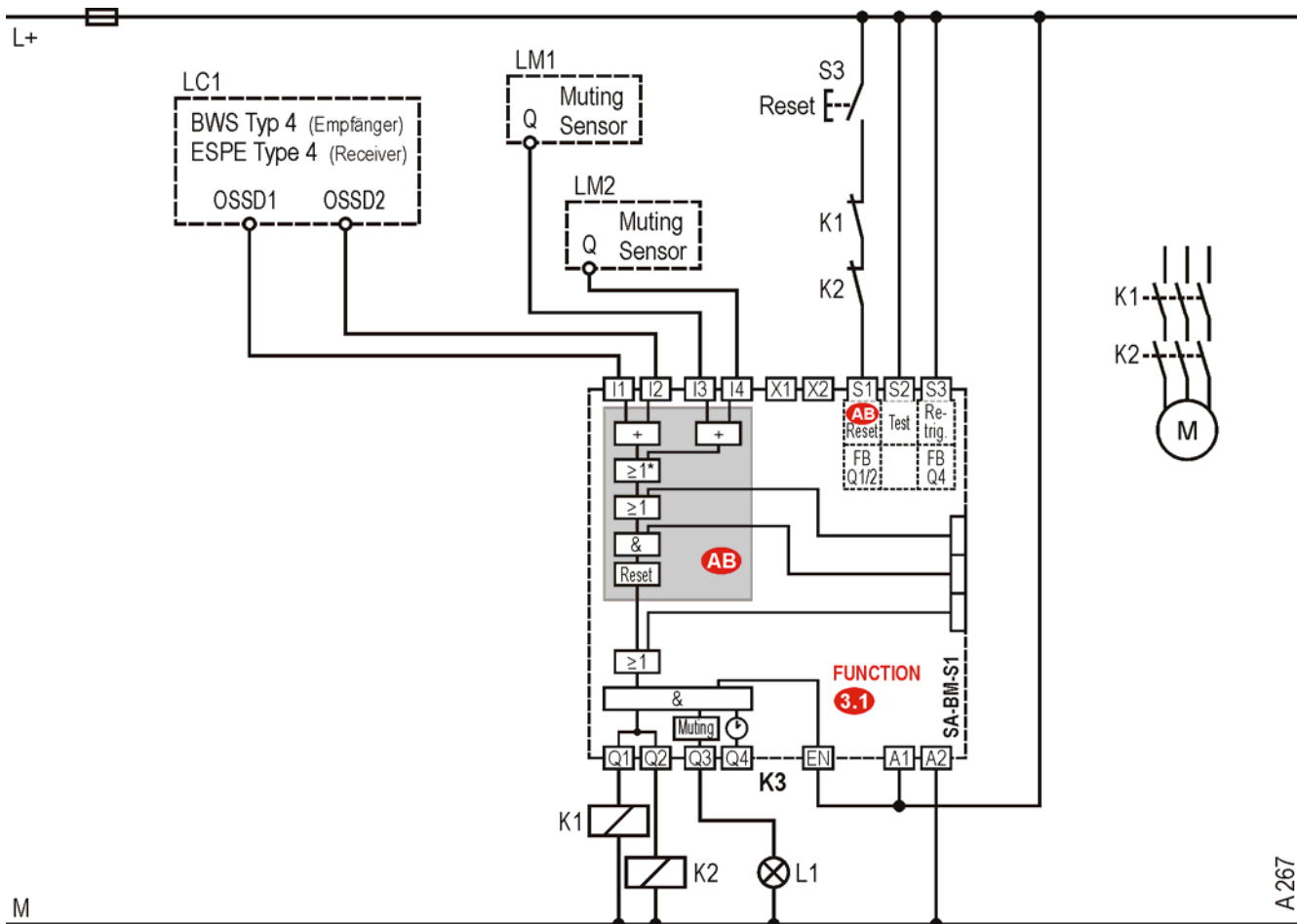

Machine zone protection with light curtain and muting function.

The safety light curtain LC1 monitors the access to the machine zone. The optical muting sensors LM1 and LM2 are OR-linked with light curtain LC1 (muting function). Both muting sensors must be activated to carry out the muting function (light curtain bypass). The muting function requires outputs Q1, Q2, Q4 to have previously been switched on.

This means that the flow sight section of LC1 has to be uninterrupted for power on. Lamp L1 indicates the active muting state (static on). The expected reset signal at S1 is indicated by blinking of L1. The lamp is monitored according to EN 60496-1. Restart is possible after exiting the danger zone and activating reset button S3.

Two-Channel Light Curtain Monitor (ESPE Type 4)

Type of Device	SNA 4064K (AC/DC 24 V)	
Category	Application (acc. to EN 954-1)	4
	Stop category (acc. to EN 60204-1)	0
Application Features	<ul style="list-style-type: none"> • 2-channel monitor • cross monitoring using the light curtains • ground-fault detection • manual, monitored reset • monitoring of external contactors (EDM) 	
Safety Sensors	ESPE type 4 (semiconductor, type C4000, Sick)	
Remarks/Notes	<p>(1) OSSD has high level when the switch is in "OK" position.</p> <p>(2) If the Safety devices are in the same control cabinet or protective wiring is used then 1-channel control of the contactors/expansion devices is acceptable.</p>	

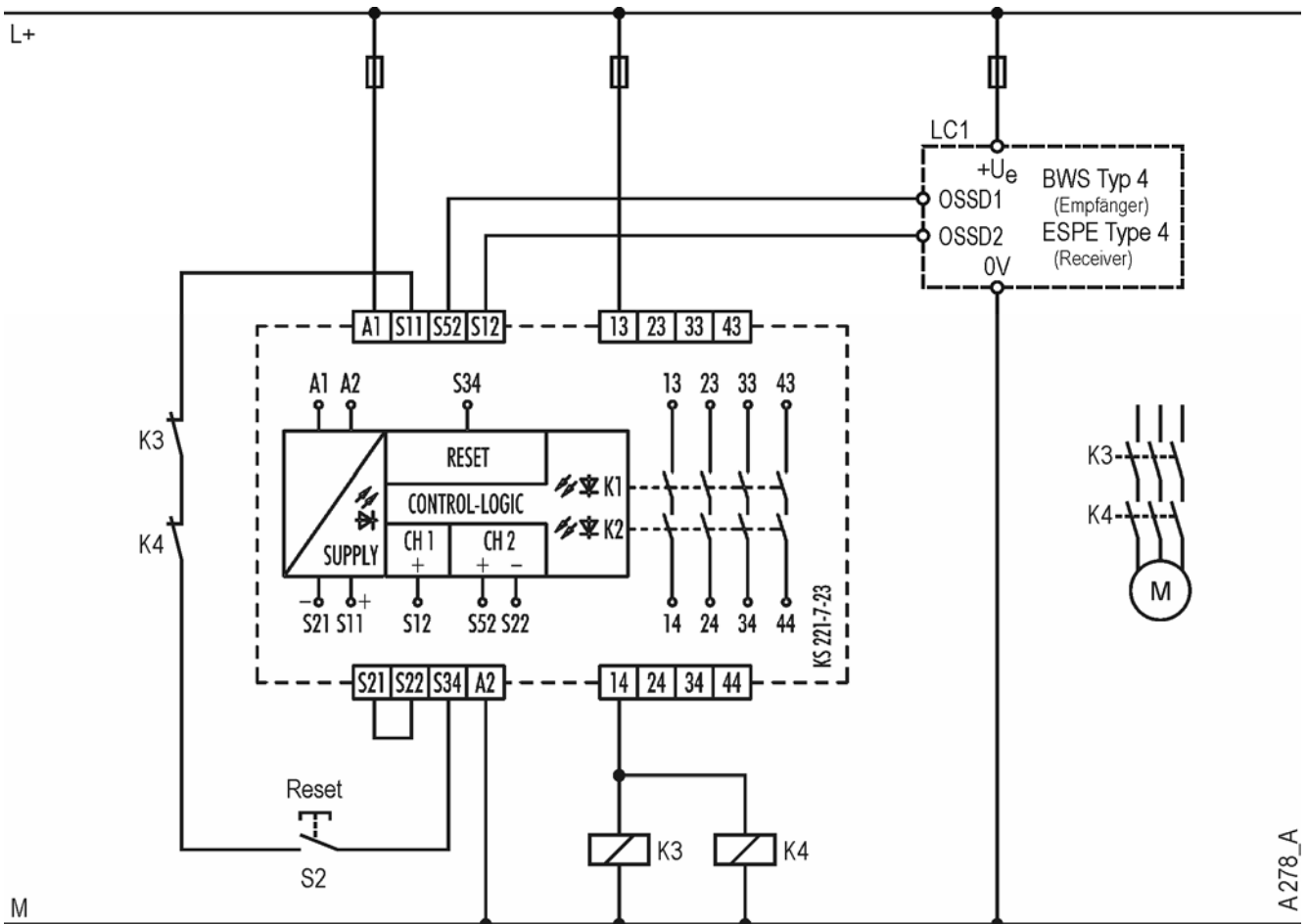

Two-channel light curtain monitoring (cross monitoring) with manual, monitored reset.

The safety switching device and the contactors K3, K4 are switched on when the light curtain's OSSD issues a HIGH signal, the feedback loop (NC contacts K3, K4) is closed and the reset button is actuated after the standby time has elapsed. If the light curtain's OSSD issues a LOW signal, the safety switching device and the contactors K3, K4 switch off.

Two-Channel Light Curtain Monitoring (ESPE Type 4)

Type of Device	SNE 4003K	
Category	Application (acc. to EN 954-1)	4
	Stop category (acc. to EN 60204-1)	0
Application Features	<ul style="list-style-type: none"> • 2-channel monitor • cross monitoring using the light curtains • external reset • monitoring of external contactors (EDM) • self test of OSSD 	
Safety Sensors	ESPE type 4 (semiconductor, type C4000, Sick)	
Remarks/Notes	OSSD has high level when the switch is in "OK" position.	

3

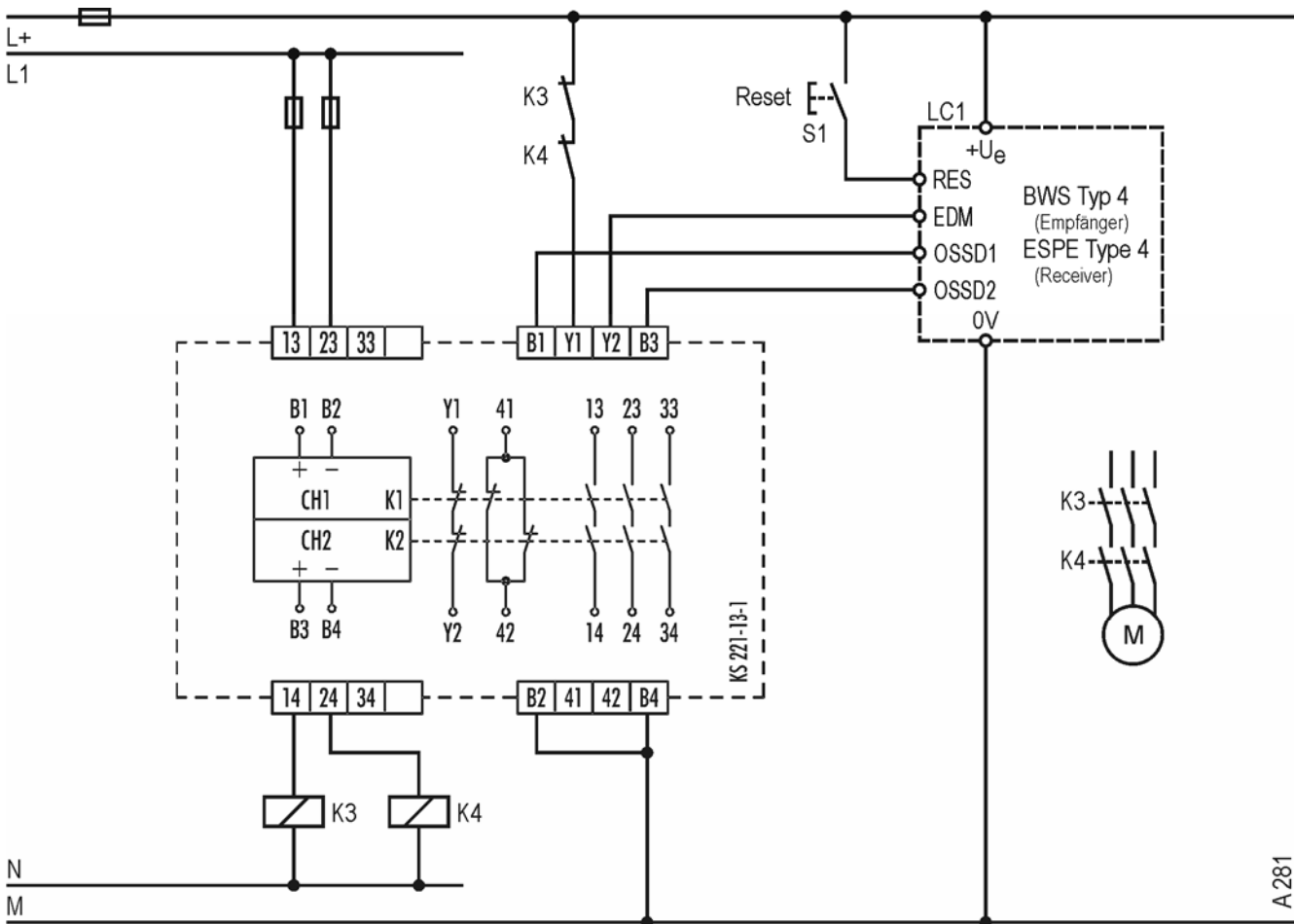

Two-channel light curtain monitoring (cross monitoring) with manual, monitored reset.

The safety switching device and the contactors K3, K4 are switched on when the light curtain's OSSD issues a HIGH signal and the feedback loop (NC contacts K3, K4) connected to the ESPE is closed and the external manual reset button of the ESPE is actuated. If the light curtain's OSSD issues a LOW signal, the safety switching device and the contactors K3, K4 switch off.

Two-Channel Light Curtain Monitoring (ESPE Type 4)

Type of Device	SNO 4062K	
Category	Application (acc. to EN 954-1)	4
	Stop category (acc. to EN 60204-1)	0
Application Features	<ul style="list-style-type: none"> • 2-channel monitor • cross monitoring using the light curtains • manual, monitored reset • monitoring of external contactors (EDM) • self test of OSSD 	
Safety Sensors	ESPE type 4 (semiconductor, type C4000, Sick)	
Remarks/Notes	OSSD has high level when the switch is in "OK" position.	

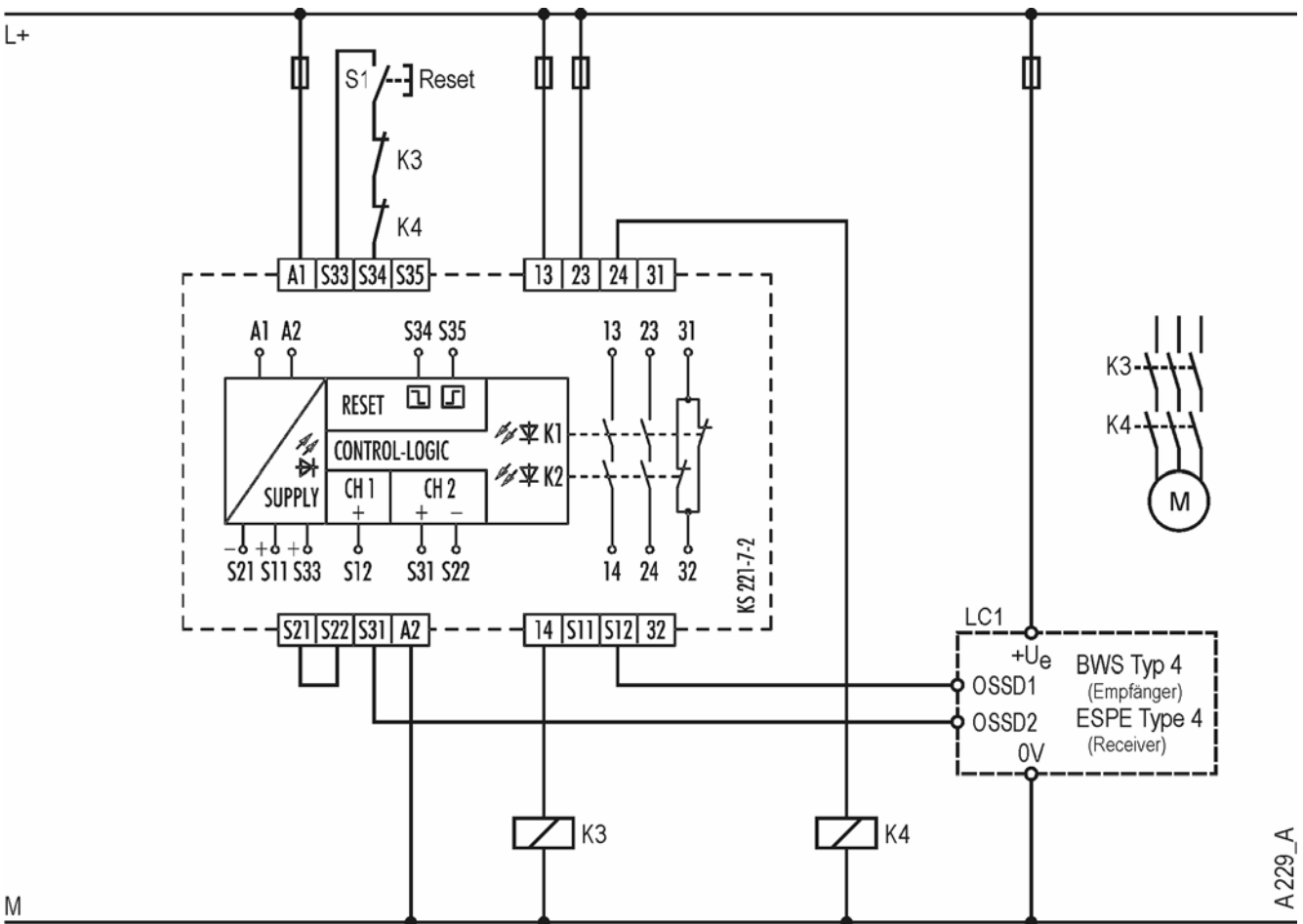

Two-channel light curtain monitoring (cross monitoring) with manual, monitored reset.

The safety switching device and the contactors K3, K4 are switched on when the light curtain's OSSD issues a HIGH signal, the feedback loop (NC contacts K3, K4) is closed and the reset button is actuated and released again. If the light curtain's OSSD issues a LOW signal, the safety switching device and the contactors K3, K4 switch off.

4 Two-Hand Control

Cat-egory ¹⁾	Device	Safety sensors Features	Reset / start and restart inhibit	Stop category ²⁾	Applica-tion number	Page
4	SNZ 4052K	Two-hand momentary contact switches	automatic	0	A 149	4 • 2

¹⁾ acc. to EN 954-1 ²⁾ acc. to EN 60204-1

Two-Channel Two-Hand Control Monitor

Type of Device	SNZ 4052K (AC/DC 24 V)	
Category	Application (acc. to EN 954-1)	4
	Stop category (acc. to EN 60204-1)	0
Application Features	<ul style="list-style-type: none"> • 2-channel monitor • ground-fault detection • automatic reset • monitoring of external contactors (EDM) • synchronous monitoring time 0.5 s 	
Safety Sensors	Two-hand momentary contact switches	
Remarks/Notes	Two-hand control according to type III C complying with EN 574-1	

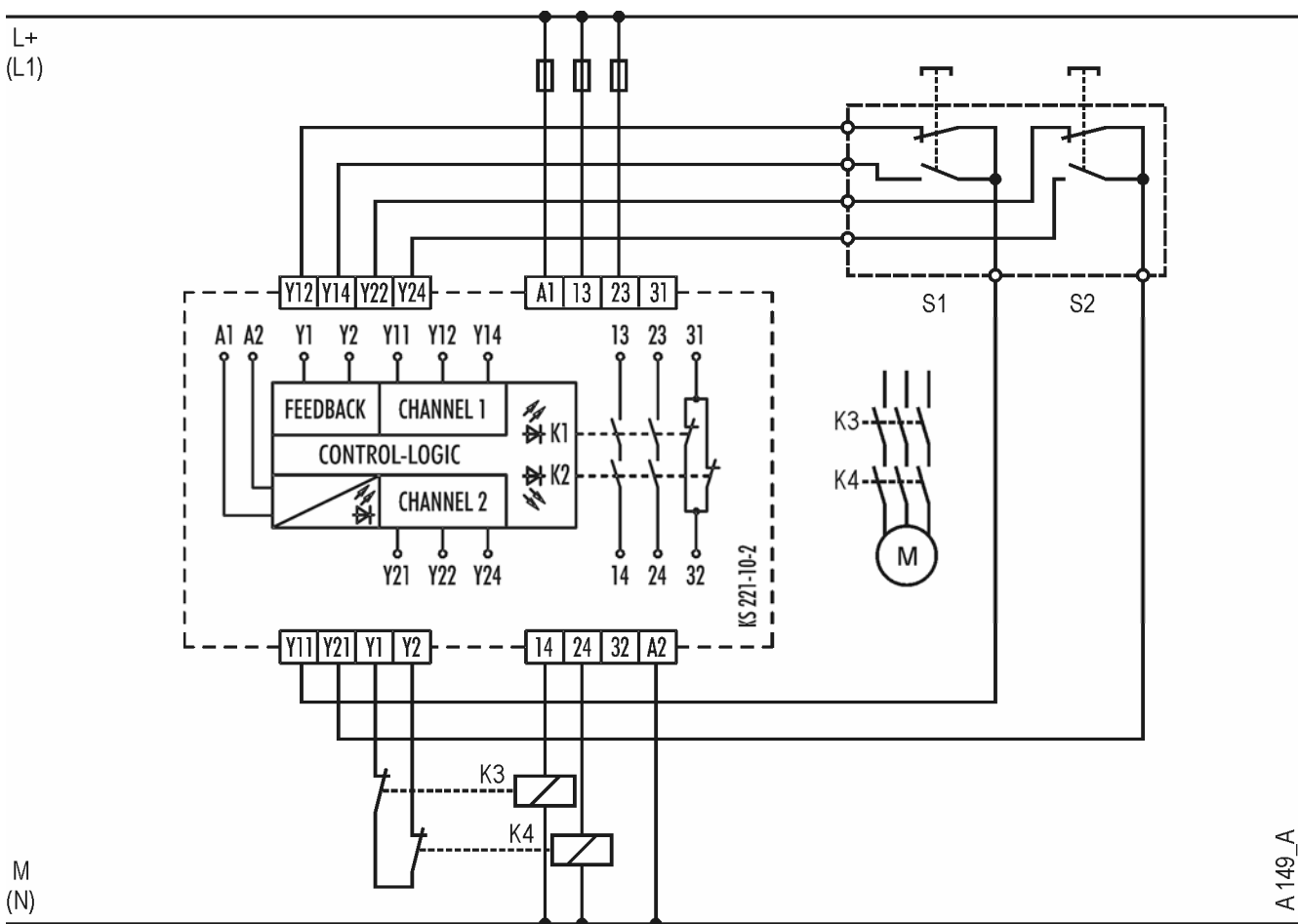

Two-hand control monitoring with automatic reset.

The safety switching device and the contactors K3, K4 are switched on when both two-hand buttons have not yet been actuated and both buttons are then activated within a timeframe of 0.5 seconds. The feedback circuit (NC contacts K3, K4) must also be closed. Should one or both buttons be released, the safety switching device and the contactors K3, K4 will switch off.

5 Safety Mat

Cat- egory ¹⁾	Device	Safety sensors Features	Reset / start and restart inhibit	Stop category ²⁾	Applica- tion number	Page
2	SNO 4062KM	Safety mat with NC contacts (interrupting)	manual, monitor	0	A 217	5 • 2
3	SNO 4062KM	Safety mat with NO contacts (short-circuiting)	manual, monitor	0	A 156	5 • 3

¹⁾ acc. to EN 954-1 ²⁾ acc. to EN 60204-1

Single-Channel Safety Mat Monitor

Type of Device	SNO 4062KM	
Category	Application (acc. to EN 954-1)	2
	Stop category (acc. to EN 60204-1)	0
Application Features	<ul style="list-style-type: none"> • 1-channel monitor • manual, monitored reset • monitoring of external contactors (EDM) 	
Safety Sensors	Safety mat with NC contacts (interrupting), type HSM, Haake	
Remarks/Notes	If the Safety devices are in the same control cabinet or protective wiring is used then 1-channel control of the contactors/expansion devices is acceptable.	

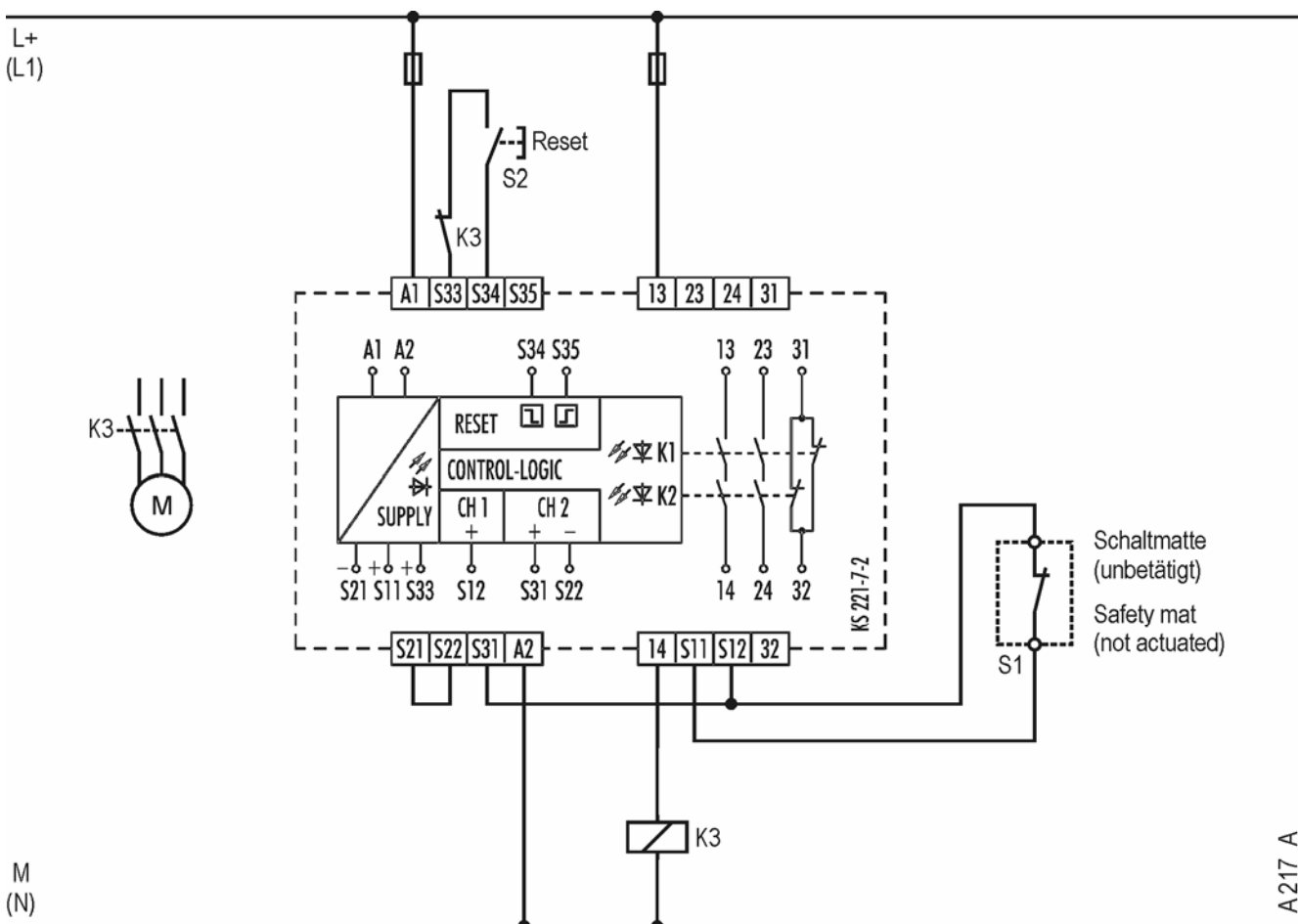

5

Single-channel safety mat monitoring with manual, monitored reset.

The safety switching device and the contactor K3 are switched on when the safety mat is not actuated, the feedback circuit (NC contact K3) is closed and the reset button is actuated and released again. Should the safety mat be stepped on, the safety switching device and the contactor K3 will switch off.

Caution: The protective devices must be tested regularly via machine control or manually (organizational measure). Category 2 according to EN 954-1 can only be attained when an automatic warning is issued on actuator failure or the machine control initiates a safe status. Otherwise, a second switch-off method is necessary.

Two-Channel Safety Mat Monitor

Type of Device	SNO 4062KM	
Category	Application (acc. to EN 954-1)	3
	Stop category (acc. to EN 60204-1)	0
Application Features	<ul style="list-style-type: none"> • 2-channel monitor • cross monitoring • manual, monitored reset • monitoring of external contactors (EDM) 	
Safety Sensors	Safety mat with NO contacts (short-circuiting)	
Remarks/Notes	If the Safety devices are in the same control cabinet or protective wiring is used then 1-channel control of the contactors/expansion devices is acceptable.	

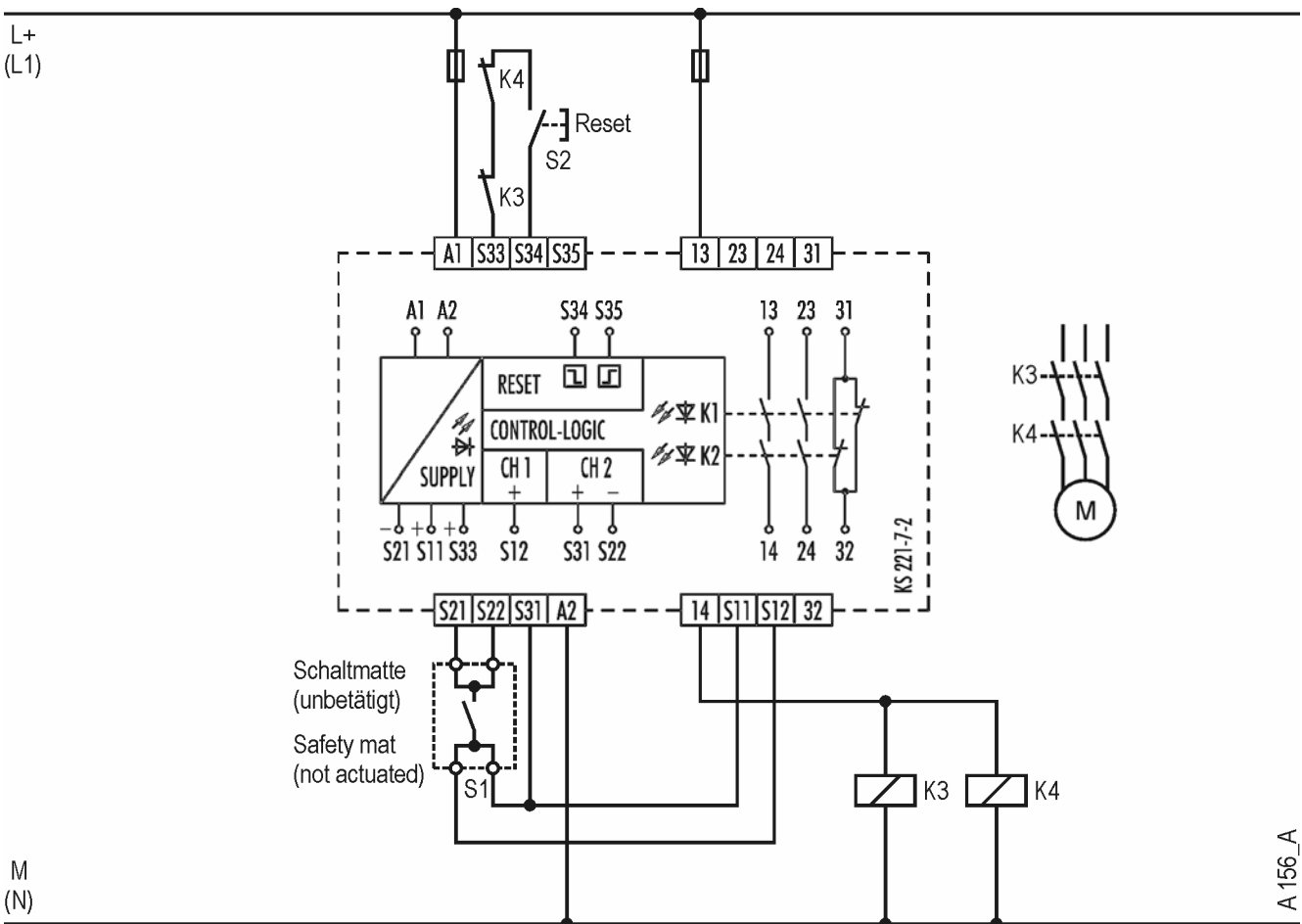

Two-channel safety mat monitoring (cross monitoring) with manual, monitored reset.

The safety switching device and the contactors K3, K4 are switched on when the safety mat is not actuated, the feedback circuit (NC contacts K3, K4) is closed and the reset button is actuated and released again. Should the safety mat be stepped on, the safety switching device and the contactors K3, K4 will switch off.

6 Lift

Cat- egory ¹⁾	Device	Safety sensors Features	Reset / start and restart inhibit	Stop category ²⁾	Applica- tion number	Page
– ³⁾	SNA 4043K	Position switches	external	– ³⁾	A 275	6 • 2

¹⁾ acc. to EN 954-1 ²⁾ acc. to EN 60204-1 ³⁾ not applicable

Position Monitor of Lift Cage in Elevator System

Type of Device	SNA 4043K (all voltage versions)	
Category	Application (acc. to EN 954-1)	– (not applicable)
	Stop category (acc. to EN 60204-1)	– (not applicable)
Application Features	<ul style="list-style-type: none"> • Device according to EN 81-1/-2 • 2-channel monitor • cross monitoring • ground-fault detection • External reset using the lift control 	
Safety Sensors	Position switches	
Remarks/Notes	Position switches cannot be connected in series because fault detection cannot be ensured.	

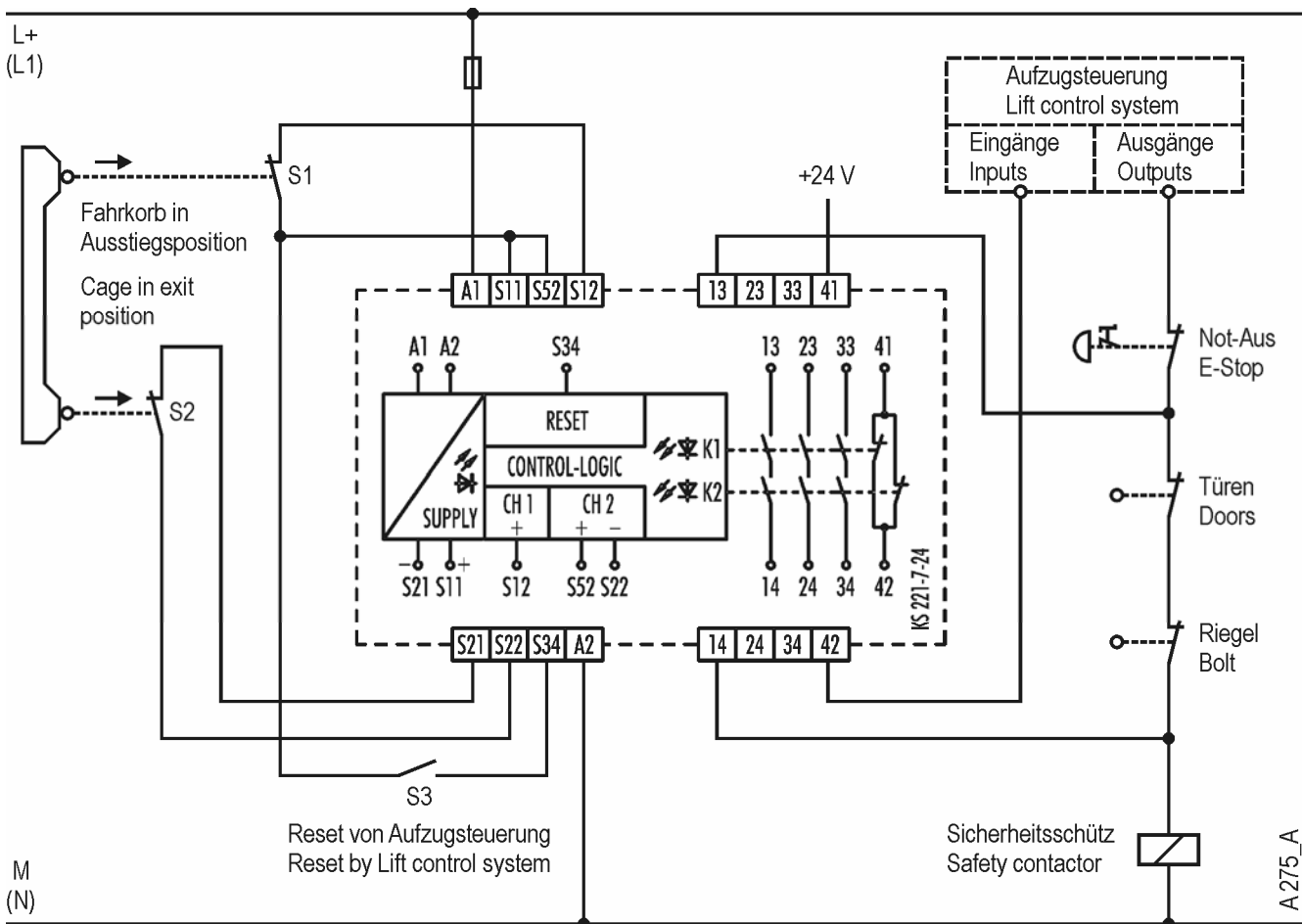

Two-channel position detection (cross monitoring) of elevator system lift cage.

The safety switching device and the safety contactor are switched on when the NC contacts of position switches S1 and S2 are closed (the lift cage must be within the maximum permissible limits of ± 20 cm from the point of exit) and the elevator control issues the signal for switching on the safety switching device. If one of the contactors of either position switch is opened, the safety switching device and the contactors K3, K4 are switched off.

7 Combustion Plant

Cat-egory ¹⁾	Device	Safety sensors Features	Reset / start and restart inhibit	Stop category ²⁾	Applica-tion number	Page
– ³⁾	SNA 4063K	Temperature monitoring equipment contact expansion	external, monitor	– ³⁾	A 280	7 • 2

¹⁾ acc. to EN 954-1 ²⁾ acc. to EN 60204-1 ³⁾ not applicable

Temperature Monitoring Equipment Contact Expansion

Type of Device	SNA 4063K (all voltage versions)	
Category	Application (acc. to EN 954-1)	4
	Stop category (acc. to EN 60204-1)	0
Application Features	<ul style="list-style-type: none"> • Device according to EN 50156-1 • 1-channel monitor • ground-fault detection • external monitored reset 	
Safety Sensors	Safety temperature monitor	
Remarks/Notes	-	

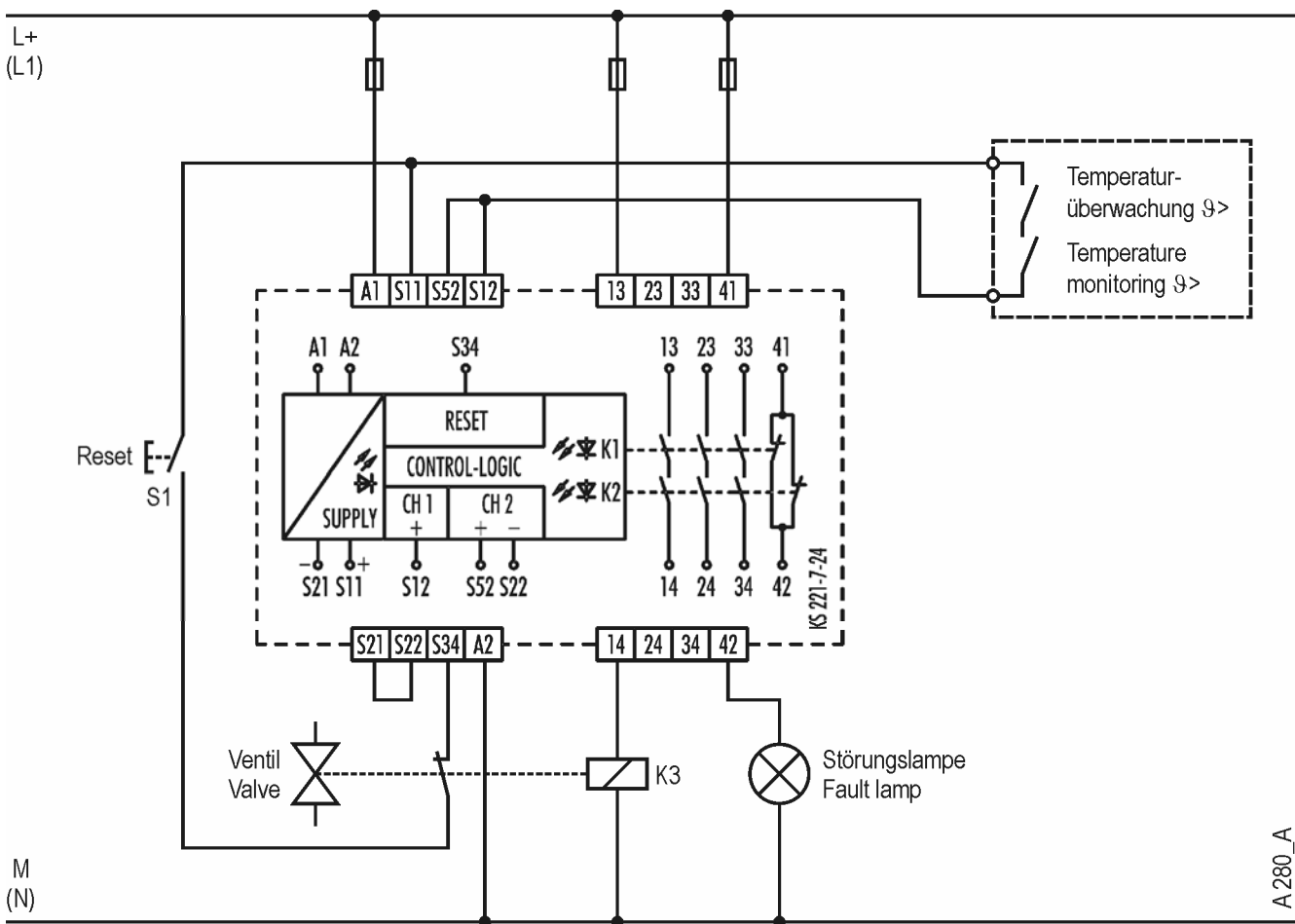

7

Temperature monitoring contact extension with manual, monitored start.

The safety switching device is switched on when the temperature monitoring contacts are closed, the valve adjuster contact is closed and the reset button is actuated after the standby time has elapsed. When the temperature monitoring contacts open, the safety switching device and the valve K3 are switched off and the fault lamp blinks.

A 280_A



A Appendix

Standards

Type A standards: basic safety standards

Contain basic concepts, principles for design and general aspects that can be applied to all machines, devices and installations, such as EN 1050 Safety of Machines – Risk evaluation.

Type B standards: group safety standards

Dealing with one safety aspect or one type of safety related equipment that can be used across a wide range of machines, devices and installations.

Type B1 standards relate to special safety aspects (for example, safety distances, surface temperature, noise).

Type B2 standards relate to safety related devices (for example, two-hand controls, locking devices, contact mats, isolating protective equipment).

Type C standards: machine safety standards

(Specific standards) contain all detailed safety requirements for a particular machine or group of machines. Specific standards include also specific safety characteristics of single machines or machine groups (about 400 C standards exist).

→ For the manufacturer of machines and installations the C standards are the basic guidelines.

Important Standards

- **EN 292 (EN ISO 12100)**
Machine Safety – basic terms, general design principles
- **EN 418**
Machine Safety – emergency stop equipment, functional aspects, general design principles
- **EN 574**
Machine Safety – two-hand control stations, functional aspects, general design principles
- **EN 954-1**
Machine Safety – safety related parts of control;
Part 1: General Design Principles
- **EN 1050 (EN ISO 14121)**
Machine Safety – principles for risk assessment
- **EN 1088**
Machine Safety – interlocking devices associated with guards
- **EN 60204-1**
Machine Safety – electrical equipment of machines;
Part 1: General Requirements
- **EN 61496-1**
Machine Safety – electrosensitive protective equipment;
Part 1: General Requirements and Inspection
- **EN 62061**
Machine Safety – functional safety of safety-related electrical, electronic and programmable electronic control systems
- **EN 13849-1**
Machine Safety – safety related parts of control;
Part 1: General Design Principles
- **EN ISO 13849-2**
Machine Safety – safety related parts of control;
Part 2: Validation
- **EN 81-1**
Safety rules for the construction and installation of elevators;
Part 1: Electrically-operated passenger and freight elevators
- **EN 50156-1**
Electrical equipment for furnaces
Part 1: Requirements for application design and installation

Standards and Regulations

Categories according to EN 954-1

Selection of the safety category

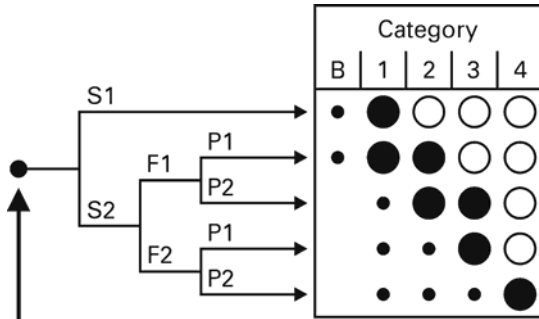

Basis for a risk estimate of the control's safety-related part

S – Seriousness of harm

- S1 Slightly harmed (normally reversible)
- S2 Seriously harmed (normally irreversible); including death

F – Frequency and/or duration of exposure to hazard

- F1 Rare to more frequently and/or short duration of exposure
- F2 Frequent to continuous and/or long duration of exposure

P – Possibility of avoiding hazard

- P1 Possible under certain conditions
- P2 Hardly possible

Selection of the category

B, 1-4 Categories for safety-related parts of controls

- Preferred category for reference points
- Possible category that requires additional measures
- Measures that can be overdimensioned with regard to the relevant risk

Example of fault detection in the safety switching device:

Fault detection in the safety switching devices means for category 3 that as many faults as possible are detected in the safety switching device. The consideration refers only to the unit, that is from the input through the internal processing to the output.

In addition, category 4 includes detection of all faults in the device and self-monitoring. External wiring plays a major role for fault detection. When a safety switching device with internal fault detection as per category 4 and a two-channel wiring with cross monitoring is used, the wiring also meets the requirements of category 4.

An application with single-channel wiring of a category 4 device does no longer fulfill the requirements of category 4.

Actuation of safety switching devices

on the basis of EN 954-1, EN 1088, EN 292-2. Examples:

Category B, 1, 2:

Use of one switching element, single-channel actuation



Not-Aus E-Stop

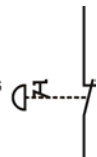

Category 3:

Use of two switching elements, two-channel actuation without cross monitoring



Not-Aus E-Stop

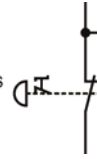

Category 4:

Use of two switching elements, two-channel actuation with cross monitoring



Not-Aus E-Stop

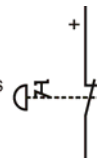

Categories of safety-related parts of controls

according to EN 954-1 "Safety of machines; safety-related parts of controls; section 1: General design guidelines"

Category	Brief description of the requirements	System behavior ¹⁾	Principles for achieving safety
B	The safety-related parts of controls and/or their protective equipment as well as their components must be designed, constructed, selected, arranged and combined as per the appropriate standards, so that they can withstand the expected influences.	Occurrence of a fault may cause failure of the safety functions.	Mainly characterized by the selection of components
1	The requirements of B must be fulfilled. Proven components and proven safety principles must be applied.	Occurrence of a fault may cause failure of the safety functions, but the probability for this occurrence is lower than under category B.	
2	The requirements of B and application of the proven safety principles must be fulfilled. The safety functions must be tested by the machine control within appropriate time intervals.	Occurrence of a fault may cause failure of the safety functions between the testing intervals. Failure of the safety function is detected during this test.	Mainly characterized by the structure
3	The requirements of B and application of the proven safety principles must be fulfilled. Safety-related parts must be designed in a way that a single fault in any of these parts does not cause failure of the safety functions, and that this single fault is detected whenever it is reasonably possible.	When the individual fault occurs, the safety function is always maintained. Some, but not all faults are detected. An accumulation of undetected faults may cause failure of the safety functions.	
4	The requirements of B and application of the proven safety principles must be fulfilled. Safety-related parts must be designed in a way that: a single fault in any of these parts does not cause failure of the safety functions, and that this single fault is detected during or prior to the demand for the safety functions; or, if this is not possible, an accumulation of errors shall not cause failure of the safety functions.	When faults occur, the safety function is always maintained. The faults are detected in time, in order to prevent failure of the safety functions.	

¹⁾ Risk evaluation will determine whether an entire or partial failure of the safety function(s) caused by faults is acceptable.

Standards and Regulations

Summary Analysis

Risk assessment and risk minimization for plant and machines

This simplified description outlines the basics of risk analysis for planners and designers. For more detailed information please consult the relevant norms.



*) Risk analysis e.g. as per EN 292 (new EN ISO 12100)

**) Risk assessment and minimization e.g. as per EN 1050 (new EN ISO 14121)

Legal requirements and standards for machines and their safety areas in the USA

This brief overview does not provide a complete collection of the requirements applicable in the USA. The owner of the machine is obliged to obtain the valid regional rules. Other than in Europe there are no uniform national laws in the USA for manufacturers/suppliers of machines and systems regarding the safety of machines. However, employers must generally provide workstations free of risk of accident or other impact to health. These key requirements are stipulated by OSHA (Occupational Safety and Health Act) 1970.

OSHA

OSHA employs regional inspectors who verify that the valid rules are followed. The OSHA rules applicable for occupational safety are available in OSHA 29 CFR 1910.xxx (CFR:Code of Federal Regulations). See www.osha.gov. Similar to Europe, product-specific standards take priority of general standards. For the industrial area the following OSHA safety standards currently apply:

- 1910.211, Definitions
- 1910.212, General requirements for all machines
- 1910.213, Woodworking machinery requirement
- 1910.214, Cooperage machinery [Reserved]
- 1910.215, Abrasive wheel machinery
- 1910.216, Mills and calendars in the rubber and plastics industries.
- 1910.217, Mechanical power presses
- 1910.218, Forging machines
- 1910.219, Mechanical power-transmission apparatus

The OSHA rules describe minimum requirements to guarantee safe workstations. However, they are not restrictive, but provide room for new technologies that guarantee safety in a different way. For certain applications it is required that all electrical devices used to protect the employees are approved by a Nationally Recognized Testing Laboratory (NRTL) authorized by OSHA.

Concepts and technologies for the safety of machines are also available under:
http://www.osha.gov/Publications/Mach_SafeGuard/toc.html

CONCEPTS AND TECHNIQUES OF MACHINE SAFEGUARDING

U.S. Department of Labor Occupational Safety and Health Administration OSHA 3067, 1992 (Revised)

Table of Contents

Introduction

Chapter 1 – Basics of Machine Safeguarding

Chapter 2 – Methods of Machine Safeguarding

Chapter 3 – Guard Construction

Chapter 4 – Machinery Maintenance and Repair

Chapter 5 – Utilization of Industry Consensus Standards

Chapter 6 – Robotics in the Workplace

Chapter 7 – Cellular Manufacturing Systems

Chapter 8 – Ergonomic Considerations of Machine Safeguarding

Chapter 9 – Cooperation and Assistance Machine Guarding Checklist

Product liability, NFPA, ANSI

The current standards of NFPA and ANSI as well as the rules for product liability in the USA must be followed also. Through product liability the manufacturers and owners are “forced” for their own benefit to carefully follow the regulations and fulfill the state-of-the-art. In case of an accident, the companies have to prove that the generally accepted safety principles were used.

Two particularly important standards for safety in the industry are NFPA 70 and NFPA 79 (Electrical Standard for Industrial Machinery). They describe the basic requirements of the properties and design of electrical equipment.

The regulations in NFPA 70 mainly apply for buildings, but also for electrical connections of machines and machine sections. NFPA 79 applies for electrical equipment in industrial machines with rated voltages smaller than 600 V, whereas both standards are to be used for large conveyor systems, for example.

Groups of machines that work together in coordination (= systems) are also considered as a machine. NFPA 79-2002 includes basic requirements for programmable electronics and buses that are used to perform safety-related functions (among others also emergency stop functions of stop category 0 or 1). For emergency stop functions, NFPA 79 requires isolation of electrical power through electromechanical equipment. A protection comparable to the protection of permanently wired controls must be achieved.

IEC 61508 is indicated as the appropriate standard for the requirements of such systems. Software-based and firmwarebased controllers that are used in safety-related functions must be listed (and certified by NRTL) for these applications.

Under ANSI B11 there are various other standards for safety in the industry that provide additional instructions on how to achieve the required safety. For example:

- ANSI B11.19-2003: “Performance Criteria for Safeguarding”
- ANSI/RIA R 15.06-1999: “Industrial Robots and Robot Systems – Safety Requirements”
- ANSI B11 TR3-2000: “Risk Assessment and Risk Reduction – A guide to Estimate, Evaluate, and Reduce Risks Associated with Machine Tools”.

See www.ansi.org

Terms

Terms and Definitions (in alphabetical order)

1-channel monitor

→ Control, safety-related

2-channel monitor

→ Control, safety-related

Base device

Evaluation unit that includes all basic functions which must be available in safety equipment at a minimum in order to create a safety-related output signal. The requirements for electric/ electronic/programmable electronic systems (E/E/PES) are stipulated in EN 61508-2.

→ Expansion device

Cable Length

In large plants, long cable lines to the Transducers are the norm. In the case of safety switching devices, the line resistance of the Transducers circuit cannot be exceeded. A 2.5-km long copper line with a cross section of 2 to 1.5 mm² has an ohmic resistance of 70 Ohms (a 2-core copper line has an ohmic resistance of 28 Ohm/km at 25 °C).

In some safety switching devices, the safety sensors are located in the AC supply lines of the devices. Independent of the cable routing, the capacitive coupling – which could negatively influence the switch-off response – must also be taken into consideration. For details on maximum cable lengths, refer to the technical data sheets or the operating instructions of the respective devices.

Cable-operated switch

→ Transducers

Category (acc. to EN 954-1)

→ Safety category

Contact expansion

→ Expansion device

Controlled stop

→ Safe stopping process, → Stop category

Control, safety-related

Single-channel control:

Control via one transducer output.

Two-channel control:

Control via two transducer outputs.

Cross monitoring

Capability of an → SD to detect shunt faults immediately after fault detection or during a cyclic monitoring (→ Testing) and switching into the defined safe state.

Cyclic test

→ Testing

E/E/PES

Electrical/Electronic/Programmable Electronic Systems.

[EN 61508-2]

EDM

External Device Monitoring. Monitoring with controlled devices.

Note: the → SD can only be activated when the feedback circuit is closed. In the case of relays and contactors, positively driven contacts provide the safe feedback. The NC contacts of the monitored relay, which are connected in series, are integrated into the feedback circuit of the safety switching device. If a contact bonds in the enabling current path, then a new activation of the SD is no longer possible since the feedback circuit remains open.

Emergency stop

An action performed in case of emergency that is intended to stop a process or movement that would be dangerous.

[EN 60204-1, appendix D]

Emergency stop button

→ Transducers

Emergency stop equipment

Formation of components that is intended to realize the emergency stop function.

[EN 418 / EN 60947 5 5 / EN 60204 1]

Enabling current path

Generates a safety-related output signal.

Note: The enabling current paths are implemented primarily as NO contacts.

Enabling switches

→ Transducers

Equivalent Control

Control with equivalent contacts, for example NC/NC contacts.

ESPE

Electro-Sensitive Protective Equipment. Basically a sensor function and its corresponding control/monitoring function with output switching element.

Expansion device

An expansion device is an → SD that can only be used together with a → base device for the purpose of multiplying the contacts.

Difference:

Output expansion device for the purpose of multiplying the safety outputs; they are then included in the cyclic self-monitoring (→ Testing).

Input expansion device for the purpose of multiplying the safety inputs.

Feedback Loop

→ EDM

Feedback Path

→ EDM

Ground-fault detection

Capability of a → SD to detect ground faults immediately or within the context of cyclic monitoring (→ Testing) and initiate the appropriate safe status.

Isolating safety equipment

Mechanical isolation between the hazardous area and the environment of operation.

Note: Isolation can be achieved through safety gates, housings, covers, sheetings, canopies, fences, screens, etc. Isolation can be independent or part of the machine.

Laser scanners

→ Transducers

Light barrier

→ Transducers

Light curtain

→ Transducers

Light gate

→ Transducers

Locking mechanism

→ Safety gate monitor

Magnetic switch

→ Transducers

Muting

Time-limited proper cancellation (shunting function) of the safety function with additional sensor system.

[IEC / DIN EN 61496 1]

Note: This sensor system helps to distinguish persons and objects.

Muting sensors

→ Transducers

Non-equivalent Control

Control with non-equivalent contacts, for example NC/NO contacts.

OSSD

Output Switching Signal Device. [IEC / DIN EN 61496]

Part of the → ESPE / → PDF, which switches into the OFF position if the → SD or the monitoring equipment responds.

PDF

→ Transducers

Performance Level (PL)

Term from prEN ISO 13849-1 as classification of machine safety.

Periodic test

→ Transducers

Position switch

→ Transducers

Positively Opening Contacts

Contact separation as the direct result of a defined movement of a switch's operating component through non-springing parts. [IEC/DIN EN 60204-1]

Note 1: For electrical machine equipment the safe opening of NC contacts in all safety circuits is mandatory.

Note 2: Positive opening is identified according to IEC/DIN EN 60947-5-1 by the sign  (arrow inside a circle; function for operator protection).

Proximity switch

→ Transducers

Redundancy

Availability of more measures than required for the function.

Note: Several function groups are used for the same function (for example multi-channel design). In safety technology especially "Doubling of critical components". [EN 292 2]

Reset

Resetting/returning the → SD to the position in which the safety-oriented current paths are closed.

Automatic reset (without restart inhibit):

With the input image checked and a positive test performed by the → SD, an enable signal is generated without manual confirmation.

Note: This function is also called dynamic operation; it is not permissible for emergency stop equipment.

Manual reset (with restart inhibit):

By pressing the reset button (→ Transducers), and with the input image checked and a positive test performed by the → SD, an enabling signal is generated.

Note: This function is also known as static operation and is stipulated for emergency stop equipment (→ Stop category). [IEC / DIN EN 60204 1]

Manual monitored reset (with restart inhibit)

Similar to a → manual reset, with the addition of a monitoring device that prevents not only permanent actuation (i.e., manipulation) of the reset button (→ Transducers) but also automatic switch-on of the → SD.

Reset button

→ Transducers

Restart inhibit

Prevents the enable of an → SD after switch-off, after change of the machine's operating mode or after a change of the type of operation.

Note: Restart inhibit is only released by an external command (such as → Transducers/Reset button).

Terms

Transducers

Laser scanners

are optical scanners that work without contact and with periodically emitted light pulses that are diffused into the work area by integrated rotary mirrors. Objects that penetrate the defined protective field are detected through reflection of these light pulses. The coordinates of these "obstacles" are then calculated from the light duration. If the "obstacle" is found to be within the defined protective field, the safety-related outputs cause a switch-off (→ emergency stop).

Safety gates or protective light curtains

change their switching state when one or more light beam(s) is (are) interrupted.

Protective light barriers

change their switching state when their light beam is interrupted.

Magnetic switches

consisting of one or more reed contacts, change their switching state under the influence of a magnetic field.

Muting sensors

are used during muting operation (→ Muting) in order to recognize bodies for which → ESPE shall not switch off.

Proximity switches

(inductive, optical or capacitive) change their switching state when bodies or fluids approach. They are mainly equipped with semiconductor outputs.

Emergency stop buttons

for activation in hazardous situations are used to switch off processes, machines or systems. It must be equipped with positively opening contacts, should be easily accessible and protected against circumvention. [EN 418]

Note: Emergency stop buttons can be connected in series for all categories, since the possibility of both failure and simultaneous operation of several emergency stop buttons can be excluded for all practical purposes. Connecting in series does not impair fault detection.

PDF

(Proximity Devices with defined behavior under Fault conditions) are proximity switches for safety functions that trigger a certain switching operation due to a change in optical, magnetic, electrostatic, acoustic or other fields. The switching signal created during this operation may be used for safetyrelevant controls of machines.

Note: Proximity switches for safety functions consist of the components: *sensor* (active part), *evaluation device* including the safety outputs, and *operating device* (defined object).

Position switch

is part of a locking unit within → isolating protective equipment. It changes a switching state dependent on a mechanically triggered control command. There are position switches with or without locking mechanism (→ Safety gate monitor).

Note: Position switches belong to the safety-related control functions. They can only be series connected when it is certain that no safety gates are simultaneously opened or regular inspection is guaranteed! Otherwise, faults could be masked, leading in an increase in faults reducing safety functionality. As this is difficult to identify in practice, all safety gates need to be monitored simultaneously.

Reset buttons

within → SDs function as → restart inhibit that is only released by pressing.

Safety mats, safety plates, safety strips, safety edges change their switching state when being stepped on (safety mat) or deformed (switching strips, switching edges). [EN 1760 1/ 2]

Cable-operated switches

cause a stop category 0, if an emergency trip wire is pulled or the cable tears apart.

→ Stop category

Enable switches

must be actuated manually in order to release the protective effect of protective equipment. With this switch alone, no hazardous states may be enabled; a "second, deliberate" command is required for that.

Safe stopping process

Stopping of the drive appropriate for the hazardous situation (→ Stop category).

Note: Any electrical, electronic and electromechanical equipment required for the deceleration of the drive must be considered for safety matters. Relevant measures are, for example:

- Controlled stop with safely monitored delay time
- Controlled stop with safe monitoring of the deceleration ramp
- Uncontrolled stop with mechanical deceleration

Safety category

[EN 954 1]. Classification of the safety-related parts of a control in view of its resistance (SK B, 1, 2, 3, and 4) to faults and its behavior in case of a fault that is achieved by the structural arrangement of these parts and/or their reliability.

Safety device

Abbreviation used here for safety-relevant evaluation device, such as safety control, → safety switching device, evaluation unit.

Safety gate monitor

Monitors the position of position switches on → isolating protective equipment. It generates a safety-related output signal when this safety gate is closed. Safety gates can be implemented with or without a tumbler (latching). The tumbler (locking mechanism) locks the safety gate in its closed position. It is connected to the controls in such a way that the machine cannot operate as long as the safety gate is not closed and locked. The safety gate remains locked until the risk of injury has been eliminated. [EN 1088]

→ Transducers/Position switch

Safety Integrity Level (SIL)

Term from EN 62061 as classification of machine safety.

Safety mats, safety plates, safety strips, safety edges

→ Transducers

Safety sensors

→ Transducers

Safety switching device

Device used to evaluate safety-related input signals and to generate safe output switching signals.

SC

Abbreviation used here for semiconductor.

SD

→ Safety device

Shunt fault

Electrically conducting connection / short circuit between the safety-relevant input channels of an → SD.

Note: A shunt fault can only occur with multi-channel device control.

Signaling current path

Generates a non-safety-related output signal.

Start

→ Reset

Start inhibit

Function that prevents automatic machine start when the power supply of the → SD is switched on or interrupted and switched on again.

Stop category

[EN 60204 -1]. Electrical machine shutdown is classified in categories 0, 1 and 2.

Stop category 0

Uncontrolled stop through immediate switch-off of the power to the machine's drive components.

Stop category 1

Controlled stop with interruption of the power supply upon arrival at the standstill position.

Stop category 2

Controlled stop with the power supply maintained in the standstill position.

→ Safe stopping process

Synchrocheck

→ Synchronous time monitoring

Synchronous monitoring time

Period of time during which a simultaneous operation must be performed in order to create an output signal.

→ Two-hand control

Synchronous time monitoring

Synchronous time monitoring of transducers via the safety-relevant evaluation unit is used to increase the functional safety of the protective equipment. Monitoring is carried out by monitoring the signal change of the Transducers within a specified period of time. This is referred to as the so-called → synchronous monitoring time. If this time is exceeded, no enabling signal will be output. Synchronous time monitoring is required by regulation for some safety switching devices (→ Two-hand control).

Testing

Periodic test

The periodic test for → ESPE type 2 simulates activation of the sensor element in order to detect a hazardous failure. It is mandatory for proving proper functioning of ESPE type 2 according to EN 61496 1 and is performed by the → SD connected to the sensor.

Cyclic test

Before or during the next request of the safety function, an error is detected, i.e. at every switch-on cycle of the → SD at the latest.

Tumbler

→ Safety gate monitor

Two-hand control

Equipment that requires simultaneous operation of both hands in order to trigger and maintain machine operation as long as there is danger and in order to achieve protection of the operating personnel only. [EN 574]

Note: In order to trigger the hazardous operation step, both operating components must be operated simultaneously (→ Synchronous monitoring time). If only one of the two actuators is released during this hazardous movement, the enable is released immediately. Continuation of the hazardous operation step can only be achieved, if both operating components have returned to their initial state and are operated again.

Uncontrolled stop

→ Safe stopping process, → Stop category

Wiring

By taking special measures while wiring (for example, separate wiring of 2-channel applications or protected wiring), users can exclude faults due to short circuits in the sensor wiring (for example, cross monitoring).

Part Numbers

Type	Rated voltage	Brief description	Terminals	Part number
samos				
SA-BM-S1-4EKL-A, 0-5s	DC 24 V	Master base module, programming via switches	Pluggable screw connection	R1.180.0010.0
SA-BM-S1-4EKL-A, 0-50s	DC 24 V	Master base module, programming via switches	Pluggable screw connection	R1.180.0020.0
SA-BM-S1-4EKL-A, 0-5min	DC 24 V	Master base module, programming via switches	Pluggable screw connection	R1.180.0030.0
SA-BM-S1-4EKL-C, 0-5s	DC 24 V	Master base module, programming via switches	Pluggable spring tech. connection	R1.180.0360.0
SA-BM-S1-4EKL-C, 0-50s	DC 24 V	Master base module, programming via switches	Pluggable spring tech. connection	R1.180.0370.0
SA-BM-S1-4EKL-C, 0-5min	DC 24 V	Master base module, programming via switches	Pluggable spring tech. connection	R1.180.0380.0
SA-BS-S1-4EKL-A, 0-5s	DC 24 V	Slave base module, programming via switches	Pluggable screw connection	R1.180.0040.0
SA-BS-S1-4EKL-A, 0-50s	DC 24 V	Slave base module, programming via switches	Pluggable screw connection	R1.180.0050.0
SA-BS-S1-4EKL-A, 0-5min	DC 24 V	Slave base module, programming via switches	Pluggable screw connection	R1.180.0060.0
SA-BS-S1-4EKL-C, 0-5s	DC 24 V	Slave base module, programming via switches	Pluggable spring tech. connection	R1.180.0390.0
SA-BS-S1-4EKL-C, 0-50s	DC 24 V	Slave base module, programming via switches	Pluggable spring tech. connection	R1.180.0400.0
SA-BS-S1-4EKL-C, 0-5min	DC 24 V	Slave base module, programming via switches	Pluggable spring tech. connection	R1.180.0410.0
SA-IN-S1-K-A	DC 24 V	Input module, programming via switches	Pluggable screw connection	R1.180.0070.0
SA-IN-S1-K-C	DC 24 V	Input module, programming via switches	Pluggable spring tech. connection	R1.180.0420.0
SA-OR-S1-4RK-A	DC 24 V	Relay output module	Pluggable screw connection	R1.180.0080.0
SA-OR-S2-2RK-A	DC 24 V	Relay output module	Pluggable screw connection	R1.180.0320.0
SA-OR-S1-4RK-C	DC 24 V	Relay output module	Pluggable spring tech. connection	R1.180.0430.0
SA-OR-S2-2RK-C	DC 24 V	Relay output module	Pluggable spring tech. connection	R1.180.0440.0
SA-PROFIBUS-DP-A	DC 24 V	Bus coupling module Profibus DP	Pluggable screw connection	R1.180.0090.0
SA-PROFIBUS-DP-C	DC 24 V	Bus coupling module Profibus DP	Pluggable spring tech. connection	R1.180.0450.0
SA-CANopen-A	DC 24 V	Bus coupling module CANopen	Pluggable screw connection	R1.180.0100.0
SA-CANopen-C	DC 24 V	Bus coupling module CANopen	Pluggable spring tech. connection	R1.180.0460.0
SA-DeviceNet-A	DC 24 V	Bus coupling module DeviceNet	Pluggable screw connection	R1.180.0350.0
SA-DeviceNet-C	DC 24 V	Bus coupling module DeviceNet	Pluggable spring tech. connection	R1.180.0470.0
SAMOS-HANDBUCH-D		Manual		R1.180.0280.0
SAMOS-MANUAL-GB		Manual		R1.180.0290.0
SAMOS-HANDBUCH-Buskoppler-D		Manual		R1.180.0330.0
SAMOS-MANUAL-Buscoupling-GB		Manual		R1.180.0340.0
SNA 4043K	AC/DC 24 V	Emergency stop and safety gate monitor	Fixed screw connection	R1.188.1680.0
SNA 4043K	AC 42-48 V	Emergency stop and safety gate monitor	Fixed screw connection	R1.188.1690.0
SNA 4043K	AC 115-120 V	Emergency stop and safety gate monitor	Fixed screw connection	R1.188.1700.0
SNA 4043K	AC 230 V	Emergency stop and safety gate monitor	Fixed screw connection	R1.188.1710.0
SNA 4043K-A	AC/DC 24 V	Emergency stop and safety gate monitor	Pluggable screw connection	R1.188.1810.0
SNA 4043K-C	AC/DC 24 V	Emergency stop and safety gate monitor	Pluggable spring tech. connection	R1.188.1940.0
SNA 4044K	AC/DC 24 V	Emergency stop and safety gate monitor	Fixed screw connection	R1.188.1730.0
SNA 4044K	AC 42-48 V	Emergency stop and safety gate monitor	Fixed screw connection	R1.188.1740.0
SNA 4044K	AC 115-120 V	Emergency stop and safety gate monitor	Fixed screw connection	R1.188.1750.0
SNA 4044K	AC 230 V	Emergency stop and safety gate monitor	Fixed screw connection	R1.188.1760.0
SNA 4044K-A	AC/DC 24 V	Emergency stop and safety gate monitor	Pluggable screw connection	R1.188.1860.0
SNA 4044K-C	AC/DC 24 V	Emergency stop and safety gate monitor	Pluggable spring tech. connection	R1.188.1960.0
SNA 4063K	AC/DC 24 V	Emergency stop and safety gate monitor	Fixed screw connection	R1.188.1620.0
SNA 4063K	AC 42-48 V	Emergency stop and safety gate monitor	Fixed screw connection	R1.188.1720.0
SNA 4063K	AC 115-120 V	Emergency stop and safety gate monitor	Fixed screw connection	R1.188.1420.0
SNA 4063K	AC 230 V	Emergency stop and safety gate monitor	Fixed screw connection	R1.188.1430.0
SNA 4063K-A	AC/DC 24 V	Emergency stop and safety gate monitor	Pluggable screw connection	R1.188.1440.0
SNA 4063K-C	AC/DC 24 V	Emergency stop and safety gate monitor	Pluggable spring tech. connection	R1.188.1950.0
SNA 4064K	AC/DC 24 V	Emergency stop and safety gate monitor	Fixed screw connection	R1.188.1770.0
SNA 4064K	AC 42-48 V	Emergency stop and safety gate monitor	Fixed screw connection	R1.188.1780.0
SNA 4064K	AC 115-120 V	Emergency stop and safety gate monitor	Fixed screw connection	R1.188.1790.0
SNA 4064K	AC 230 V	Emergency stop and safety gate monitor	Fixed screw connection	R1.188.1800.0
SNA 4064K-A	AC/DC 24 V	Emergency stop and safety gate monitor	Pluggable screw connection	R1.188.1900.0
SNA 4064K-C	AC/DC 24 V	Emergency stop and safety gate monitor	Pluggable spring tech. connection	R1.188.1970.0

A

Type	Rated voltage	Brief description	Terminals	Part number
SNE 4003K	DC 24 V	Contact expansion device	Fixed screw connection	R1.188.1330.0
SNE 4003K-A	DC 24 V	Contact expansion device	Pluggable screw connection	R1.188.1340.0
SNE 4004K	AC/DC 24 V	Contact expansion device	Fixed screw connection	R1.188.0520.0
SNE 4004K-A	AC/DC 24 V	Contact expansion device	Pluggable screw connection	R1.188.0590.0
SNE 4004K-C	AC/DC 24 V	Contact expansion device	Pluggable spring tech. connection	R1.188.1980.0
SNE 4004KV, 0,5s	DC 24 V	Contact expansion device, OFF	Fixed screw connection	R1.188.0550.0
SNE 4004KV, 1s	DC 24 V	Contact expansion device, OFF	Fixed screw connection	R1.188.0560.0
SNE 4004KV, 2s	DC 24 V	Contact expansion device, OFF	Fixed screw connection	R1.188.0570.0
SNE 4004KV, 3s	DC 24 V	Contact expansion device, OFF	Fixed screw connection	R1.188.0580.0
SNE 4004KV-A, 0,5s	DC 24 V	Contact expansion device, OFF	Pluggable screw connection	R1.188.0460.0
SNE 4004KV-A, 1s	DC 24 V	Contact expansion device, OFF	Pluggable screw connection	R1.188.0470.0
SNE 4004KV-A, 2s	DC 24 V	Contact expansion device, OFF	Pluggable screw connection	R1.188.0480.0
SNE 4004KV-A, 3s	DC 24 V	Contact expansion device, OFF	Pluggable screw connection	R1.188.0490.0
SNE 4008S	AC/DC 24 V	Contact expansion device	Fixed screw connection	R1.188.1290.0
SNE 4008S-A	AC/DC 24 V	Contact expansion device	Pluggable screw connection	R1.188.1300.0
SNL 4062K	DC 24 V	Light curtain monitor	Fixed screw connection	R1.188.0750.1
SNL 4062K-A	DC 24 V	Light curtain monitor	Pluggable screw connection	R1.188.0830.1
SNO 2004K	AC/DC 24 V	Emergency stop and safety gate monitor	Fixed screw connection	R1.188.0410.3
SNO 2012	DC 24 V	Emergency stop and safety gate monitor	Fixed screw connection	R1.188.1090.1
SNO 2012	AC 120 V	Emergency stop and safety gate monitor	Fixed screw connection	R1.188.1080.1
SNO 2012	AC 230 V	Emergency stop and safety gate monitor	Fixed screw connection	R1.188.1100.1
SNO 4003K	AC/DC 24 V	Emergency stop and safety gate monitor	Fixed screw connection	R1.188.0400.1
SNO 4003K	AC 115-120 V	Emergency stop and safety gate monitor	Fixed screw connection	R1.188.0880.1
SNO 4003K	AC 230 V	Emergency stop and safety gate monitor	Fixed screw connection	R1.188.0890.1
SNO 4003K-A	AC/DC 24 V	Emergency stop and safety gate monitor	Pluggable screw connection	R1.188.0500.1
SNO 4003K-C	AC/DC 24 V	Emergency stop and safety gate monitor	Pluggable spring tech. connection	R1.188.1990.0
SNO 4062K	AC/DC 24 V	Emergency stop and safety gate monitor	Fixed screw connection	R1.188.0690.2
SNO 4062K-A	AC/DC 24 V	Emergency stop and safety gate monitor	Pluggable screw connection	R1.188.0700.2
SNO 4062K-C	AC/DC 24 V	Emergency stop and safety gate monitor	Pluggable spring tech. connection	R1.188.2000.0
SNO 4062KM	AC/DC 24 V	Emergency stop and safety gate monitor	Fixed screw connection	R1.188.0710.2
SNO 4062KM-A	AC/DC 24 V	Emergency stop and safety gate monitor	Pluggable screw connection	R1.188.0720.2
SNO 4063K	AC/DC 24 V	Emergency stop and safety gate monitor	Fixed screw connection	R1.188.0960.0
SNO 4063K	AC 115-120 V	Emergency stop and safety gate monitor	Fixed screw connection	R1.188.0970.0
SNO 4063K	AC 230 V	Emergency stop and safety gate monitor	Fixed screw connection	R1.188.0980.0
SNO 4063K	DC 12 V	Emergency stop and safety gate monitor	Fixed screw connection	R1.188.1110.0
SNO 4063K-A	AC/DC 24 V	Emergency stop and safety gate monitor	Pluggable screw connection	R1.188.0990.0
SNO 4063KM	AC/DC 24 V	Emergency stop and safety gate monitor	Fixed screw connection	R1.188.1270.0
SNO 4063KM-A	AC/DC 24 V	Emergency stop and safety gate monitor	Pluggable screw connection	R1.188.1280.0
SNO 5002K	DC 12 V	Emergency stop and safety gate monitor	Fixed screw connection	R1.188.1650.0
SNO 5002K	DC 24 V	Emergency stop and safety gate monitor	Fixed screw connection	R1.188.1360.0
SNO 5002K	AC 115-120 V	Emergency stop and safety gate monitor	Fixed screw connection	R1.188.1370.0
SNO 5002K	AC 230 V	Emergency stop and safety gate monitor	Fixed screw connection	R1.188.1350.0
SNT 4M63K	AC/DC 24 V	Emergency stop and safety gate monitor	Fixed screw connection	R1.188.1020.0
SNT 4M63K	AC 115-120 V	Emergency stop and safety gate monitor	Fixed screw connection	R1.188.1030.0
SNT 4M63K	AC 230 V	Emergency stop and safety gate monitor	Fixed screw connection	R1.188.1040.0
SNT 4M63K-A	AC/DC 24 V	Emergency stop and safety gate monitor	Pluggable screw connection	R1.188.1050.0



Part Numbers

Type	Rated voltage	Brief description	Terminals	Part number
SNV 4063KL, 0,15-3s	DC 24 V	Emergency stop and safety gate monitor, OFF	Fixed screw connection	R1.188.0610.0
SNV 4063KL, 1,5-30s	DC 24 V	Emergency stop and safety gate monitor, OFF	Fixed screw connection	R1.188.0630.0
SNV 4063KL-A, 0,15-3s	DC 24 V	Emergency stop and safety gate monitor, OFF	Pluggable screw connection	R1.188.0620.0
SNV 4063KL-A, 1,5-30s	DC 24 V	Emergency stop and safety gate monitor, OFF	Pluggable screw connection	R1.188.0640.0
SNV 4063KL-C, 0,15-3s	DC 24 V	Emergency stop and safety gate monitor, OFF	Pluggable spring tech. connection	R1.188.2010.0
SNV 4063KP, 0,15-3s	DC 24 V	Emergency stop and safety gate monitor, ON	Fixed screw connection	R1.188.0650.0
SNV 4063KP, 1,5-30s	DC 24 V	Emergency stop and safety gate monitor, ON	Fixed screw connection	R1.188.0670.0
SNV 4063KP-A, 0,15-3s	DC 24 V	Emergency stop and safety gate monitor, ON	Pluggable screw connection	R1.188.0660.0
SNV 4063KP-A, 1,5-30s	DC 24 V	Emergency stop and safety gate monitor, ON	Pluggable screw connection	R1.188.0680.0
SNV 4074SL, 3s	DC 24 V	Emergency stop and safety gate monitor, OFF	Fixed screw connection	R1.188.2120.0
SNV 4074SL, 3s	AC 115-230 V	Emergency stop and safety gate monitor, OFF	Fixed screw connection	R1.188.2300.0
SNV 4074SL, 30s	DC 24 V	Emergency stop and safety gate monitor, OFF	Fixed screw connection	R1.188.2150.0
SNV 4074SL, 30s	AC 115-230 V	Emergency stop and safety gate monitor, OFF	Fixed screw connection	R1.188.2330.0
SNV 4074SL, 300s	DC 24 V	Emergency stop and safety gate monitor, OFF	Fixed screw connection	R1.188.2180.0
SNV 4074SL, 300s	AC 115-230 V	Emergency stop and safety gate monitor, OFF	Fixed screw connection	R1.188.2360.0
SNV 4074SL-A, 3s	DC 24 V	Emergency stop and safety gate monitor, OFF	Pluggable screw connection	R1.188.2130.0
SNV 4074SL-A, 3s	AC 115-230 V	Emergency stop and safety gate monitor, OFF	Pluggable screw connection	R1.188.2310.0
SNV 4074SL-A, 30s	DC 24 V	Emergency stop and safety gate monitor, OFF	Pluggable screw connection	R1.188.2160.0
SNV 4074SL-A, 30s	AC 115-230 V	Emergency stop and safety gate monitor, OFF	Pluggable screw connection	R1.188.2340.0
SNV 4074SL-A, 300s	DC 24 V	Emergency stop and safety gate monitor, OFF	Pluggable screw connection	R1.188.2190.0
SNV 4074SL-A, 300s	AC 115-230 V	Emergency stop and safety gate monitor, OFF	Pluggable screw connection	R1.188.2370.0
SNV 4074SL-C, 3s	DC 24 V	Emergency stop and safety gate monitor, OFF	Pluggable spring tech. connection	R1.188.2140.0
SNV 4074SL-C, 3s	AC 115-230 V	Emergency stop and safety gate monitor, OFF	Pluggable spring tech. connection	R1.188.2320.0
SNV 4074SL-C, 30s	DC 24 V	Emergency stop and safety gate monitor, OFF	Pluggable spring tech. connection	R1.188.2170.0
SNV 4074SL-C, 30s	AC 115-230 V	Emergency stop and safety gate monitor, OFF	Pluggable spring tech. connection	R1.188.2350.0
SNV 4074SL-C, 300s	DC 24 V	Emergency stop and safety gate monitor, OFF	Pluggable spring tech. connection	R1.188.2200.0
SNV 4074SL-C, 300s	AC 115-230 V	Emergency stop and safety gate monitor, OFF	Pluggable spring tech. connection	R1.188.2380.0
SNV 4074ST, 3s	DC 24 V	Safe time delay relay, ON	Fixed screw connection	R1.188.2550.0
SNV 4074ST, 3s	AC 115-230 V	Safe time delay relay, ON	Fixed screw connection	R1.188.2730.0
SNV 4074ST, 30s	DC 24 V	Safe time delay relay, ON	Fixed screw connection	R1.188.2580.0
SNV 4074ST, 30s	AC 115-230 V	Safe time delay relay, ON	Fixed screw connection	R1.188.2760.0
SNV 4074ST, 300s	DC 24 V	Safe time delay relay, ON	Fixed screw connection	R1.188.2610.0
SNV 4074ST, 300s	AC 115-230 V	Safe time delay relay, ON	Fixed screw connection	R1.188.2790.0
SNV 4074ST -A, 3s	DC 24 V	Safe time delay relay, ON	Pluggable screw connection	R1.188.2560.0
SNV 4074ST -A, 3s	AC 115-230 V	Safe time delay relay, ON	Pluggable screw connection	R1.188.2740.0
SNV 4074ST -A, 30s	DC 24 V	Safe time delay relay, ON	Pluggable screw connection	R1.188.2590.0
SNV 4074ST -A, 30s	AC 115-230 V	Safe time delay relay, ON	Pluggable screw connection	R1.188.2770.0
SNV 4074ST -A, 300s	DC 24 V	Safe time delay relay, ON	Pluggable screw connection	R1.188.2620.0
SNV 4074ST -A, 300s	AC 115-230 V	Safe time delay relay, ON	Pluggable screw connection	R1.188.2800.0
SNV 4074ST -C, 3s	DC 24 V	Safe time delay relay, ON	Pluggable spring tech. connection	R1.188.2570.0
SNV 4074ST -C, 3s	AC 115-230 V	Safe time delay relay, ON	Pluggable spring tech. connection	R1.188.2750.0
SNV 4074ST -C, 30s	DC 24 V	Safe time delay relay, ON	Pluggable spring tech. connection	R1.188.2600.0
SNV 4074ST -C, 30s	AC 115-230 V	Safe time delay relay, ON	Pluggable spring tech. connection	R1.188.2780.0
SNV 4074ST -C, 300s	DC 24 V	Safe time delay relay, ON	Pluggable spring tech. connection	R1.188.2630.0
SNV 4074ST -C, 300s	AC 115-230 V	Safe time delay relay, ON	Pluggable spring tech. connection	R1.188.2810.0

OFF: OFF-delay
ON: ON-delay

Type	Rated voltage	Brief description	Terminals	Part number
SNV 4076SL, 3s	DC 24 V	Emergency stop and safety gate monitor, OFF	Fixed screw connection	R1.188.2030.0
SNV 4076SL, 3s	AC 115-230 V	Emergency stop and safety gate monitor, OFF	Fixed screw connection	R1.188.2210.0
SNV 4076SL, 30s	DC 24 V	Emergency stop and safety gate monitor, OFF	Fixed screw connection	R1.188.2060.0
SNV 4076SL, 30s	AC 115-230 V	Emergency stop and safety gate monitor, OFF	Fixed screw connection	R1.188.2240.0
SNV 4076SL, 300s	DC 24 V	Emergency stop and safety gate monitor, OFF	Fixed screw connection	R1.188.2090.0
SNV 4076SL, 300s	AC 115-230 V	Emergency stop and safety gate monitor, OFF	Fixed screw connection	R1.188.2270.0
SNV 4076SL-A, 3s	DC 24 V	Emergency stop and safety gate monitor, OFF	Pluggable screw connection	R1.188.2040.0
SNV 4076SL-A, 3s	AC 115-230 V	Emergency stop and safety gate monitor, OFF	Pluggable screw connection	R1.188.2220.0
SNV 4076SL-A, 30s	DC 24 V	Emergency stop and safety gate monitor, OFF	Pluggable screw connection	R1.188.2070.0
SNV 4076SL-A, 30s	AC 115-230 V	Emergency stop and safety gate monitor, OFF	Pluggable screw connection	R1.188.2250.0
SNV 4076SL-A, 300s	DC 24 V	Emergency stop and safety gate monitor, OFF	Pluggable screw connection	R1.188.2100.0
SNV 4076SL-A, 300s	AC 115-230 V	Emergency stop and safety gate monitor, OFF	Pluggable screw connection	R1.188.2280.0
SNV 4076SL-C, 3s	DC 24 V	Emergency stop and safety gate monitor, OFF	Pluggable spring tech. connection	R1.188.2050.0
SNV 4076SL-C, 3s	AC 115-230 V	Emergency stop and safety gate monitor, OFF	Pluggable spring tech. connection	R1.188.2230.0
SNV 4076SL-C, 30s	DC 24 V	Emergency stop and safety gate monitor, OFF	Pluggable spring tech. connection	R1.188.2080.0
SNV 4076SL-C, 30s	AC 115-230 V	Emergency stop and safety gate monitor, OFF	Pluggable spring tech. connection	R1.188.2260.0
SNV 4076SL-C, 300s	DC 24 V	Emergency stop and safety gate monitor, OFF	Pluggable spring tech. connection	R1.188.2110.0
SNV 4076SL-C, 300s	AC 115-230 V	Emergency stop and safety gate monitor, OFF	Pluggable spring tech. connection	R1.188.2290.0
SNV 4274SL, 3s	DC 24 V	Safe time delay relay, OFF	Fixed screw connection	R1.188.2460.0
SNV 4274SL, 3s	AC 115-230 V	Safe time delay relay, OFF	Fixed screw connection	R1.188.2640.0
SNV 4274SL, 30s	DC 24 V	Safe time delay relay, OFF	Fixed screw connection	R1.188.2490.0
SNV 4274SL, 30s	AC 115-230 V	Safe time delay relay, OFF	Fixed screw connection	R1.188.2670.0
SNV 4274SL, 300s	DC 24 V	Safe time delay relay, OFF	Fixed screw connection	R1.188.2520.0
SNV 4274SL, 300s	AC 115-230 V	Safe time delay relay, OFF	Fixed screw connection	R1.188.2700.0
SNV 4274SL -A, 3s	DC 24 V	Safe time delay relay, OFF	Pluggable screw connection	R1.188.2470.0
SNV 4274SL -A, 3s	AC 115-230 V	Safe time delay relay, OFF	Pluggable screw connection	R1.188.2650.0
SNV 4274SL -A, 30s	DC 24 V	Safe time delay relay, OFF	Pluggable screw connection	R1.188.2500.0
SNV 4274SL -A, 30s	AC 115-230 V	Safe time delay relay, OFF	Pluggable screw connection	R1.188.2680.0
SNV 4274SL -A, 300s	DC 24 V	Safe time delay relay, OFF	Pluggable screw connection	R1.188.2530.0
SNV 4274SL -A, 300s	AC 115-230 V	Safe time delay relay, OFF	Pluggable screw connection	R1.188.2710.0
SNV 4274SL -C, 3s	DC 24 V	Safe time delay relay, OFF	Pluggable spring tech. connection	R1.188.2480.0
SNV 4274SL -C, 3s	AC 115-230 V	Safe time delay relay, OFF	Pluggable spring tech. connection	R1.188.2660.0
SNV 4274SL -C, 30s	DC 24 V	Safe time delay relay, OFF	Pluggable spring tech. connection	R1.188.2510.0
SNV 4274SL -C, 30s	AC 115-230 V	Safe time delay relay, OFF	Pluggable spring tech. connection	R1.188.2690.0
SNV 4274SL -C, 300s	DC 24 V	Safe time delay relay, OFF	Pluggable spring tech. connection	R1.188.2540.0
SNV 4274SL -C, 300s	AC 115-230 V	Safe time delay relay, OFF	Pluggable spring tech. connection	R1.188.2720.0
SNZ 4052K	AC/DC 24 V	Two-hand control	Fixed screw connection	R1.188.0450.1
SNZ 4052K	AC 115-120 V	Two-hand control	Fixed screw connection	R1.188.0920.1
SNZ 4052K	AC 230 V	Two-hand control	Fixed screw connection	R1.188.0930.1
SNZ 4052K-A	AC/DC 24 V	Two-hand control	Pluggable screw connection	R1.188.0530.1
SNZ 4052K-C	AC/DC 24 V	Two-hand control	Pluggable spring tech. connection	R1.188.2020.0

OFF: OFF-delay

ON: ON-delay



Overview of Devices

APPLICATION	Emergency stop
	Safety gate
	Safety mats, strips, edges; bumper
	Light curtains, inductive sensors
	Controlled stop
	Safe time delay relay, off-delay
	Safe time delay relay, on-delay
	Locking mechanism
	Magnetic switches, valve position monitoring
	Two-hand control type III C
	Light barrier monitoring ESPE type 2
	Output expansion contact
SAFETY CATEGORY	acc. to EN 954-1 Usage up to Device(s)
SAFETY INTEGRITY LEVEL	SILcl acc. to IEC 62061 up to
PERFORMANCE LEVEL	PL, EN ISO 13849-1 up to
STOP CATEGORY	acc. to EN 60204-1
CONTROL	Single-channel Contacts
	Semiconductors
	Two-channel Contacts
	Semiconductors
Two-channel, non-equivalent	
SAFE ENABLES	NO-contact, undelayed
	NO-contact, off-delayed
	NO-contact, on-delayed
INDICATOR	NC-contact, undelayed
	NC-contact, off-delayed
	NC-contact, on-delayed
RESETFUNCTION	Manual
	Automatic
RATED VOLTAGE	DC 12 V
	DC 24 V
	AC 24 V
	AC/DC 24 V
	AC 42-48 V
	AC 115 V
	AC 120 V
	AC 230 V
FEATURE	compatible with semiconductors
	Reset button monitoring
	Cross monitoring
	Synchro check
	ON-delay
	OFF-delay
Increased insulation	
HOUSING	Surface mounting 22.5 mm
	45 mm
	90 mm
	modular





wieland

**Electrical
Connections**

Headquarters:
Wieland Electric GmbH
Brennerstraße 10 – 14
D-96052 Bamberg

Sales and Marketing Center:
Wieland Electric GmbH
Benzstraße 9
D-96052 Bamberg

Phone +49 (951) 9324-0
Fax +49 (951) 9324-198
www.wieland-electric.com
info@wieland-electric.com

**Technical Hotline:
0951/9324-999**

Product Range

AT Wieland

Components and system components for the control cabinet

- DIN rail terminal blocks
 - with screw connection
 - with spring clamp connection
 - with IDC connection
- Safety
 - Safety relays
 - Modular safety systems
- Fieldbus components
- Interface
 - Power supplies
 - Overvoltage protection
 - Measuring and monitoring relays
 - Time and switching relays
 - Coupling relays/solid state relays
 - Analog modules
 - Passive interfaces

Components and system components for field applications

- Remote automation
 - Remote power distribution
 - Remote fieldbus interface
- Industrial multipole connectors
 - Modular multipole connectors
 - High-density multipole connectors
 - High-current multipole connectors
 - Multipole connectors for hazardous areas
 - Bushings for control cabinets
 - D-Sub connectors
- Round connectors

Empty housings and appliance connectors/terminal strips

AT Schleicher

PLC systems and CNC based control systems

- Operator panels
- Application engineering & system solutions
- Customized products

BIT Wieland

Building installation systems

- Mains connectors IP20/IP65...IP68
- Bus connectors
- Combined connectors
- Low-voltage connectors
- Flexible flat cable systems
- Distribution systems
- Switching devices for EIB/KNX, LON, Ethernet, radio control
- DIN rail terminal blocks for electrical installations
- Overvoltage protection

PCB connectors Wieland

PC board connectors

- PC board connectors
 - with screw connection
 - with spring clamp connection
 - with TOP connection

