

**Manual geral de instalação, operação e manutenção
de motores elétricos**

PT

**Installation, operation and maintenance manual of
electric motors**

EN

**Manual general de instalación, operación y
mantenimiento de motores eléctricos**

ES

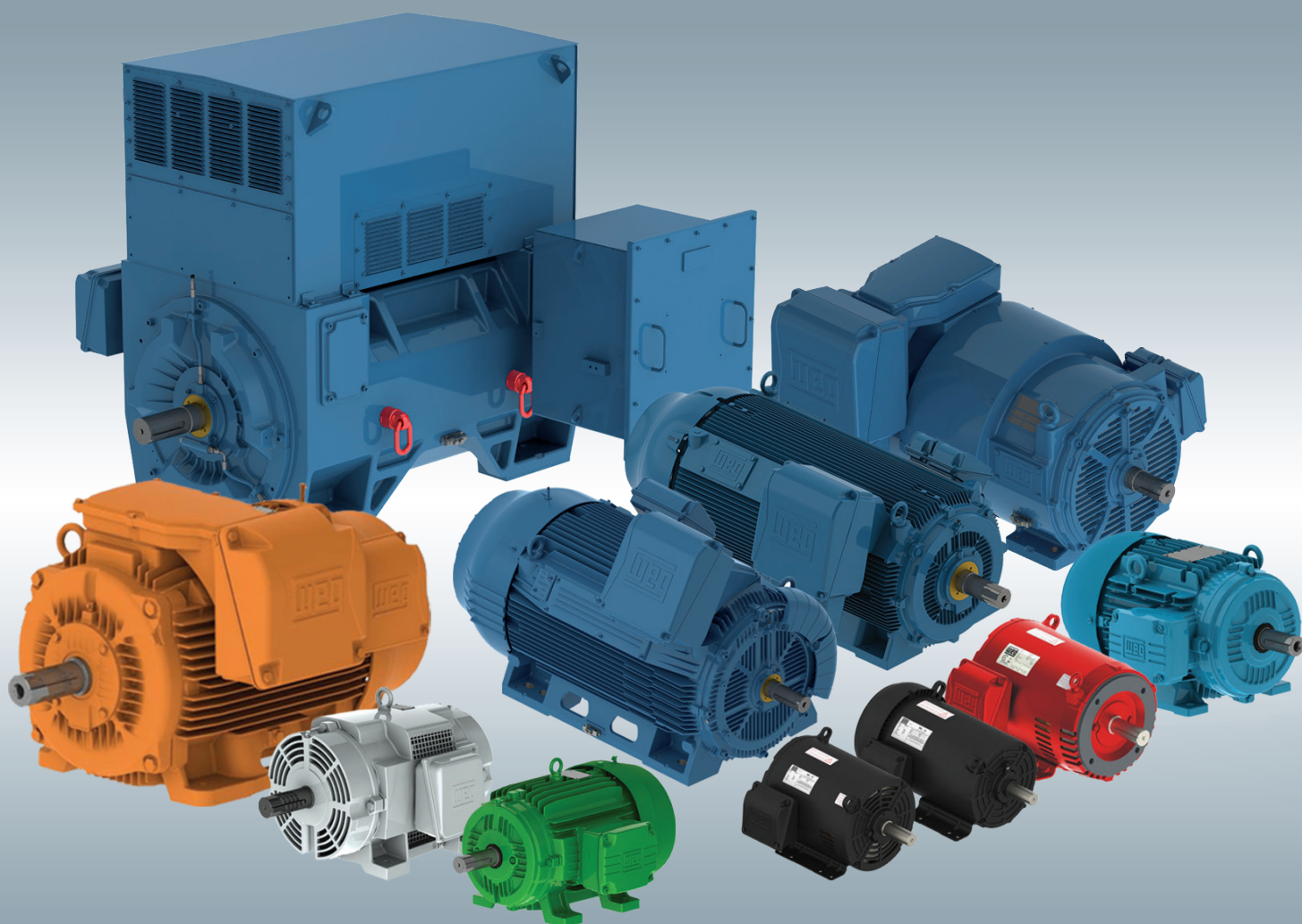

Motors | Automation | Energy | Transmission & Distribution | Coatings

Português PT

2

English EN

57

Español ES

112

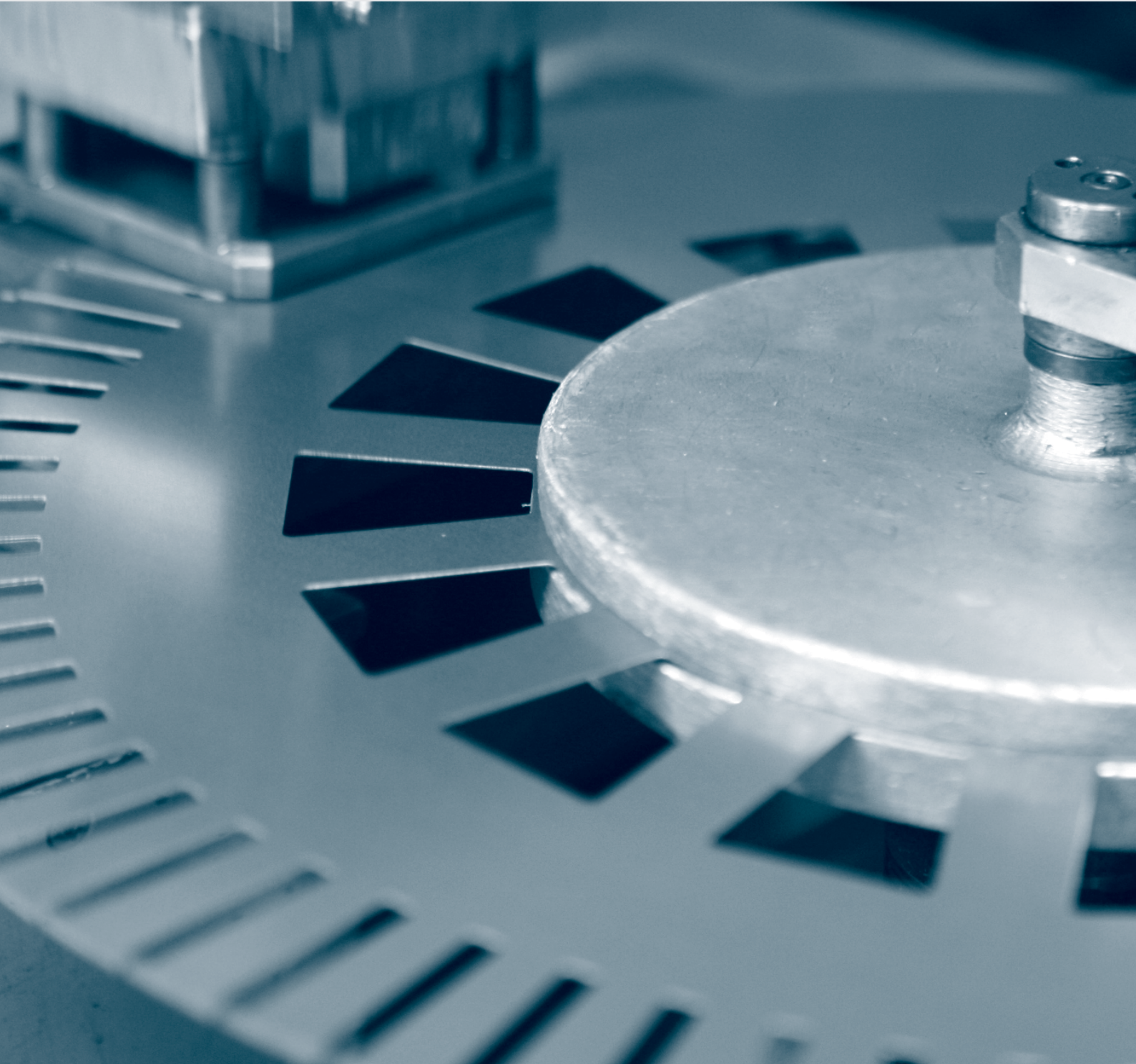

INSTALLATION, OPERATION AND MAINTENANCE MANUAL OF ELECTRIC MOTORS

This manual provides information about WEG induction motors fitted with squirrel cage, permanent magnet or hybrid rotors, low, medium and high voltage, in frame sizes IEC 56 to 630 and NEMA 42 to 9606/10.

The motor lines indicated below have additional information that can be checked in their respective manuals:

- Smoke Extraction Motors;
- Electromagnetic Brake Motors;
- Hazardous Area Motors.

These motors meet the following standards, if applicable:

- NBR 17094-1: Máquinas Elétricas Girantes - Motores de Indução - Parte 1: trifásicos.
- NBR 17094-2: Máquinas Elétricas Girantes - Motores de Indução - Parte 2: monofásicos.
- IEC 60034-1: Rotating Electrical Machines - Part 1: Rating and Performance.
- NEMA MG 1: Motors and Generators.
- CSA C 22.2 N°100: Motors and Generators.
- UL 1004-1: Rotating Electrical Machines - General Requirements.

If you have any questions regarding this manual please contact your local WEG branch, contact details can be found at www.weg.net.

TABLE OF CONTENTS

1. TERMINOLOGY	61
2. INITIAL RECOMMENDATIONS	62
2.1. WARNING SYMBOL	62
2.2. RECEIVING INSPECTION.....	62
2.3. NAMEPLATES	63
3. SAFETY INSTRUCTIONS	66
4. HANDLING AND TRANSPORT	67
4.1. LIFTING.....	67
4.1.1. Horizontal motors with one eyebolt.....	67
4.1.2. Horizontal motor with two eyebolts.....	68
4.1.3. Vertical motors	69
4.1.3.1. Procedures to place W22 motors in the vertical position	69
4.1.3.2. Procedures to place HGF and W50 motors in the vertical position.....	70
4.2 PROCEDURES TO PLACE W22 VERTICAL MOUNT MOTORS IN HORIZONTAL POSITION....	71
5. STORAGE	73
5.1. EXPOSED MACHINED SURFACES	73
5.2. STORAGE.....	73
5.3 BEARINGS	74
5.3.1 Grease lubricated bearings	74
5.3.2 Oil lubricated bearings	74
5.3.3 Oil Mist lubricated bearings	75
5.3.4 Sleeve bearing	75
5.4. INSULATION RESISTANCE.....	75
5.4.1. Insulation resistance measurement	75
6. INSTALLATION	78
6.1. FOUNDATIONS	79
6.2. MOTOR MOUNTING	81
6.2.1. Foot mounted motors.....	81
6.2.2. Flange mounted motors	81
6.2.3. Pad mounted motors	82
6.3. BALANCING	82
6.4. COUPLINGS.....	83
6.4.1. Direct coupling.....	83
6.4.2. Gearbox coupling.....	83
6.4.3. Pulley and belt coupling	83
6.4.4. Coupling of sleeve bearing motors	83
6.5. LEVELING	84
6.6. ALIGNMENT.....	84
6.7. CONNECTION OF OIL LUBRICATED OR OIL MIST LUBRICATED MOTORS	85
6.8. CONNECTION OF THE COOLING WATER SYSTEM.....	85
6.9. ELECTRICAL CONNECTION.....	85
6.10. CONNECTION OF THE THERMAL PROTECTION DEVICES.....	90
6.11. RESISTANCE TEMPERATURE DETECTORS (PT-100)	90
6.12. CONNECTION OF THE SPACE HEATERS	92

6.13. STARTING METHODS.....	93
6.14. MOTORS DRIVEN BY FREQUENCY INVERTER	94
6.14.1. Use of dV/dt filter.....	94
6.14.1.1. Motor with enameled round wire	94
6.14.1.2. Motor with prewound coils	94
6.14.2. Bearing insulation	95
6.14.3. Switching frequency.....	95
6.14.4. Mechanical speed limitation.....	96
 7. COMMISSIONING	 96
7.1. INITIAL START-UP	96
7.2. OPERATING CONDITIONS	98
7.2.1.Limits of vibration	99
 8. MAINTENANCE	 100
8.1. GENERAL INSPECTION.....	100
8.2. LUBRICATION	100
8.2.1. Grease lubricated rolling bearings	101
8.2.1.1. Motor without grease fitting	104
8.2.1.2. Motor with grease fitting.....	104
8.2.1.3. Compatibility of the Mobil Polyrex EM grease with other greases	105
8.2.2. Oil lubricated bearings	105
8.2.3. Oil mist lubricated bearings.....	106
8.2.4. Sleeve bearings	106
8.3. MOTOR ASSEMBLY AND DISASSEMBLY	107
8.3.1. Terminal box	108
8.4. DRYING THE STATOR WINDING INSULATION	108
8.5. SPARE PARTS.....	109
 9. ENVIRONMENTAL INFORMATION	 110
9.1. PACKAGING.....	110
9.2. PRODUCT.....	110
 10. TROUBLESHOOTING CHART X SOLUTIONS	 111

1. TERMINOLOGY

Balancing: the procedure by which the mass distribution of a rotor is checked and, if necessary, adjusted to ensure that the residual unbalance or the vibration of the journals and/or forces on the bearings at a frequency corresponding to service speed are within specified limits in International Standards.
[ISO 1925:2001, definition 4.1]

Balance quality grade: indicates the peak velocity amplitude of vibration, given in mm/s, of a rotor running free-in-space and it is the product of a specific unbalance and the angular velocity of the rotor at maximum operating speed.

Grounded Part: metallic part connected to the grounding system.

Live Part: conductor or conductive part intended to be energized in normal operation, including a neutral conductor.

Authorized personnel: employee who has formal approval of the company.

Qualified personnel: employee who meets the following conditions simultaneously:

- Receives training under the guidance and responsibility of a qualified and authorized professional;
- Works under the responsibility of a qualified and approved professional.

Note: *The qualification is only valid for the company that trained the employee in the conditions set out by the authorized and qualified professional responsible for training.*



2. INITIAL RECOMMENDATIONS



Electric motors have energized circuits, exposed rotating parts and hot surfaces that may cause serious injury to people during normal operation. Therefore, it is recommended that transportation, storage, installation, operation and maintenance services are always performed by qualified personnel.

Also the applicable procedures and relevant standards of the country where the machine will be installed must be considered.

Noncompliance with the recommended procedures in this manual and other references on the WEG website may cause severe personal injuries and/or substantial property damage and may void the product warranty.

For practical reasons, it is not possible to include in this Manual detailed information that covers all construction variables nor covering all possible assembly, operation or maintenance alternatives.

This Manual contains only the required information that allows qualified and trained personnel to carry out their services. The product images are shown for illustrative purpose only.

For *Smoke Extraction Motors*, please refer to the additional instruction manual 50026367 available on the website www.weg.net.

For brake motors, please refer to the information contained in WEG 50021973 brake motor manual available on the website www.weg.net.

For information about permissible radial and axial shaft loads, please check the product technical catalogue.



The user is responsible for the correct definition of the installation environment and application characteristics.



During the warranty period, all repair, overhaul and reclamation services must be carried out by WEG authorized Service Centers to maintain validity of the warranty.

2.1. WARNING SYMBOL



Warning about safety and warranty.

2.2. RECEIVING INSPECTION

All motors are tested during the manufacturing process.

The motor must be checked when received for any damage that may have occurred during the transportation.

All damages must be reported in writing to the transportation company, to the insurance company and to WEG. Failure to comply with such procedures will void the product warranty.

You must inspect the product:

- Check if nameplate data complies with the purchase order;
- Remove the shaft locking device (if any) and rotate the shaft by hand to ensure that it rotates freely. The shaft might not rotate freely in WMagnet and WQuattro motors, due to alignment torque from the magnets. It might be necessary to use a lever;



When rotating the shaft, it is necessary to certify that the terminals are insulated to eliminate the risk of electric shock from induced voltage.

- Check that the motor has not been exposed to excessive dust and moisture during the transportation. Do not remove the protective grease from the shaft, or the plugs from the cable entries. These protections must remain in place until the installation has been completed.

2.3. NAMEPLATES

The nameplate contains information that describes the construction characteristics and the performance of the motor. Figure 2.1 and Figure 2.2 show nameplate layout examples.

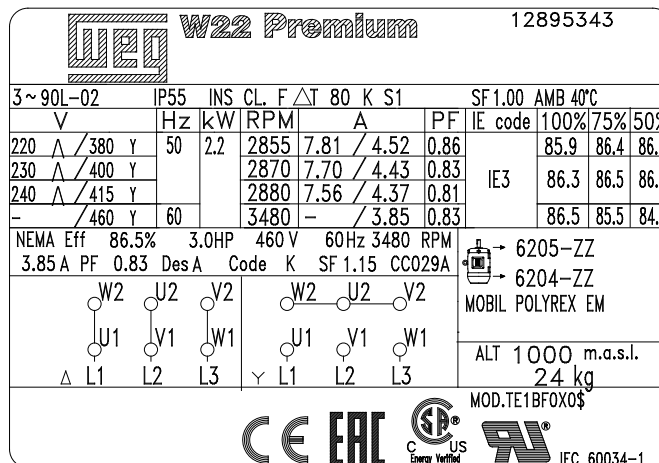
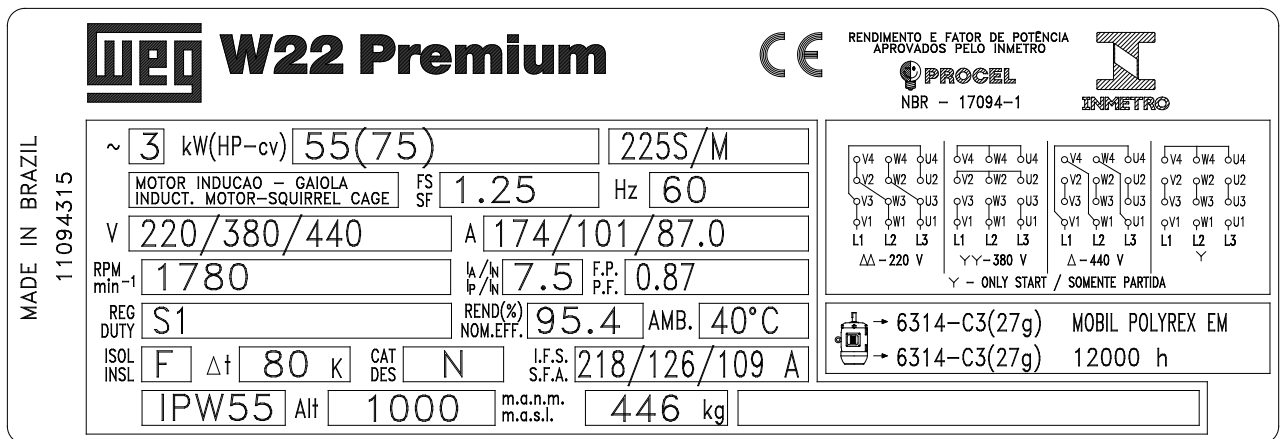
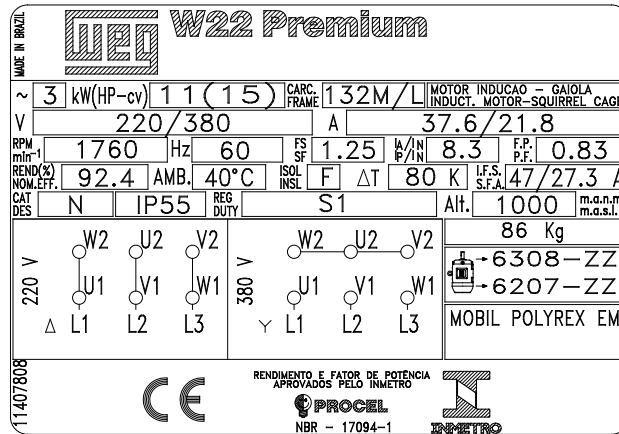

Figure 2.1 - IEC motor nameplate

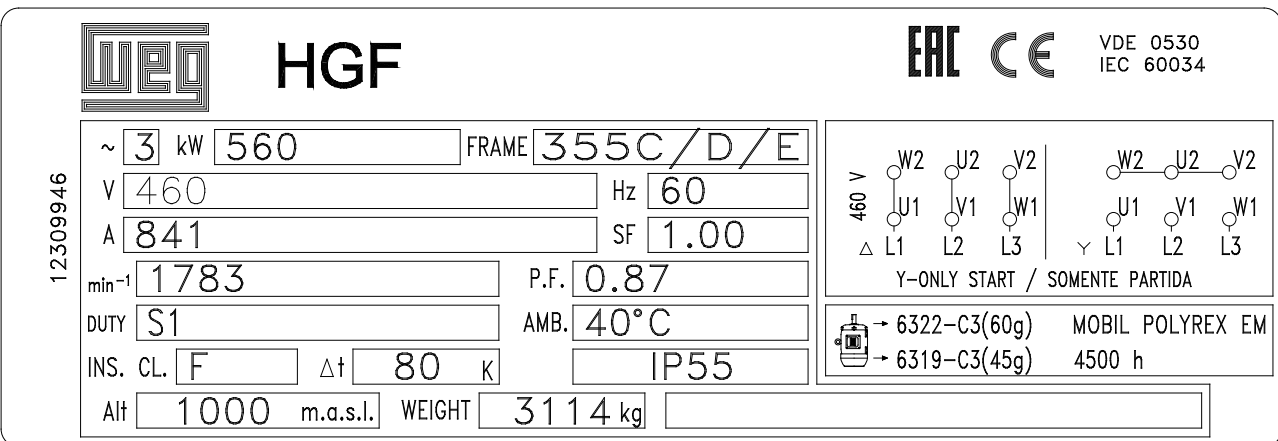
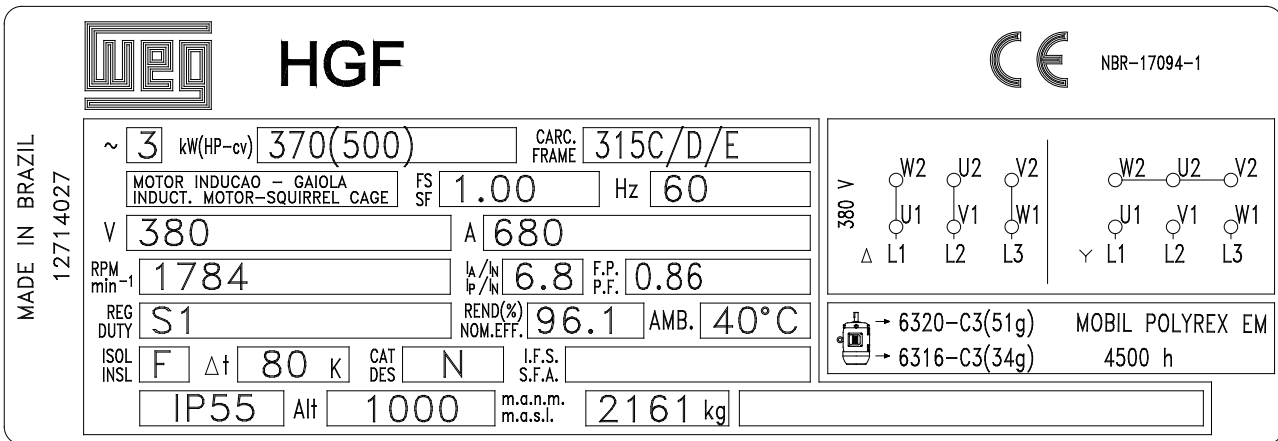
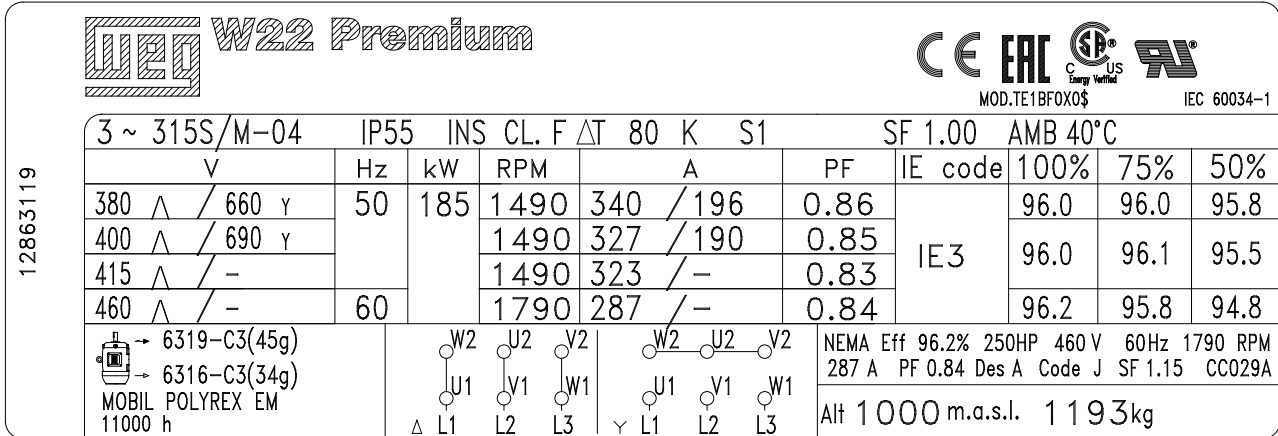

Figure 2.1 - IEC motor nameplate

W22 NEMA Premium Inverter Duty Motor Severe Duty
 MODEL:01018ET3E215T-W22

PH 3 HP(kw) 10(7.5) FRAME 213/5T RPM 1760
 V 208-230/460 Hz 60 SF 1.25 NEMA NOM. EFF. 91.7 %
 A 24.8/12.4 INS. CL. F Δt 80 k P.F. 0.83 DUTY CONT.
 SFA 31/15.5 A ENCL. TEFC IP55 AMB. 40°C ALT. 1000 m.a.s.l.
 50Hz 1 OHP 380V 15.0A 1445RPM SF1.0 CODE H DES B

11437961

USABLE AT 208V 27.4 A FOR USE ON VPWM VFD 1000:1VT, 20:1CT, 1.0SF,T3.
 Class I, Div. 2, Gr. A, B, C & D - T3
 Class I, Zone 2, IIC - T3
 Class II, Div. 2, Gr. F and G - T4

CC029A

CSA SP RUL CE

RUN CONNECTION

→ 6308-ZZ
 → 6207-ZZ
 MOBIL POLYREX EM
 MOD.TE1BFOXON 1182Lbs

W22 NEMA Premium Inverter Duty Motor Severe Duty
 CC029A FOR SAFE AREA MOD.TE1BFOXON

MADE IN BRAZIL 11166657

PH 3 HP(kw) 75(55) FRAME 364/5T
 V 208-230/460 Hz 60
 A 186-168/84.1 SF 1.25
 RPM 1775 SFA 210/105 A INS. CL. F Δt 80 k
 NEMA NOM. EFF. 95.4 % P.F. 0.86
 CODE G DES B AMB. 40°C DUTY CONT.
 ENCL. TEFC IP55 WEIGHT 923 Lbs
 USABLE AT 208V 186 A 50Hz 75HP 380V 103A 1465RPM SF1.0

Class I, Div. 2, Gr. A, B, C & D - T3
 Class I, Zone 2, IIC - T3
 Class II, Div. 2, Gr. F and G - T4

CAUTION: USE SUPPLY WIRES SUITABLE FOR 110°C

LR 110298

RUN CONNECTION

→ 6314-C3(27g) MOBIL POLYREX EM
 → 6314-C3(27g) 12000 h
 FOR USE ON VPWM VFD 1000:1VT, 20:1CT, 1.0SF,T3.
 ALT. 1000 m.a.s.l.

HGF

MADE IN BRAZIL 12774002

PH 3 HP 700 FRAME 6806/7/8T
 V 480 Hz 60
 A 755 SF 1.00
 RPM 1192 SFA INS. CL. F
 NEMA NOM. EFF. 96.5 % P.F. 0.85
 CODE G DES AMB. 40°C DUTY CONT.
 ENCL. TEFC TYPE ET WEIGHT 8339 Lbs
 Alt. 1000 m.a.s.l.

LR 110298

480 V

→ 6324-C3(72g) MOBIL POLYREX EM
 → 6319-C3(45g) 4500 h

Figure 2.2 - NEMA motor nameplate

3. SAFETY INSTRUCTIONS



The motor must be disconnected from the power supply and be completely stopped before conducting any installation or maintenance procedures. Additional measures should be taken to avoid accidental motor starting.



Professionals working with electrical installations, either in the assembly, operation or maintenance, should use proper tools and be instructed on the application of standards and safety requirements, including the use of Personal Protective Equipment (PPE) that must be carefully observed in order to reduce risk of personal injury during these services.



Electric motors have energized circuits, exposed rotating parts and hot surfaces that may cause serious injury to people during normal operation. It is recommended that transportation, storage, installation, operation and maintenance services are always performed by qualified personnel.



Pacemaker users and unqualified personnel shall not open WMagnet and WQuattro motors, because high energy magnets are used.

Always follow the safety, installation, maintenance and inspection instructions in accordance with the applicable standards in each country.

4. HANDLING AND TRANSPORT

Individually packaged motors should never be lifted by the shaft or by the packaging. They must be lifted only by means of the eyebolts, when supplied. Use always suitable lifting devices to lift the motor. Eyebolts on the frame are designed for lifting the machine weight only as indicated on the motor nameplate. Motors supplied on pallets must be lifted by the pallet base with lifting devices fully supporting the motor weight. The package should never be dropped. Handle it carefully to avoid bearing damage.



Eyebolts provided on the frame are designed for lifting the machine only. Do not use these eyebolts for lifting the motor with coupled equipment such as bases, pulleys, pumps, reducers, etc..

Never use damaged, bent or cracked eyebolts. Always check the eyebolt condition before lifting the motor.

Eyebolts mounted on components, such as on end shields, forced ventilation kits, etc. must be used for lifting these components only. Do not use them for lifting the complete machine set.

Handle the motor carefully without sudden impacts to avoid bearing damage and prevent excessive mechanical stresses on the eyebolts resulting in its rupture.



Do not handle the motors by the polymeric components: fan cover, terminal box and / or terminal box cover.



To move or transport motors with cylindrical roller bearings or angular contact ball bearings, use always the shaft locking device provided with the motor.

All HGF, W50 and W60 motors, regardless of bearing type, must be transported with shaft locking device fitted.

Vertical mounted motors with oil-lubricated bearings must be transported in the vertical position. If necessary to move or transport the motor in the horizontal position, install the shaft locking device on both sides (drive end and non-drive end) of the motor.

4.1. LIFTING



Before lifting the motor ensure that all eyebolts are tightened properly and the eyebolt shoulders are in contact with the base to be lifted, as shown in Figure 4.1. Figure 4.2 shows an incorrect tightening of the eyebolt.

Ensure that lifting machine has the required lifting capacity for the weight indicated on the motor nameplate.



Figure 4.1 - Correct tightening of the eyebolt

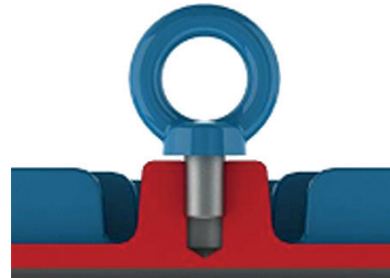

Figure 4.2 - Incorrect tightening of the eyebolt



The center-of-gravity may change depending on motor design and accessories. During the lifting procedures the maximum allowed angle of inclination should never be exceeded as specified below.

4.1.1. Horizontal motors with one eyebolt

For horizontal motors fitted with only one eyebolt, the maximum allowed angle-of-inclination during the lifting process should not exceed 30° in relation to the vertical axis, as shown in Figure 4.3.

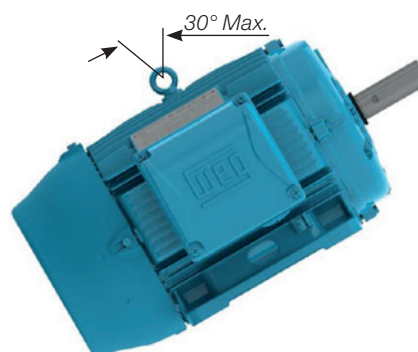

Figure 4.3 - Maximum allowed angle-of-inclination for motor with one eyebolt

4.1.2. Horizontal motor with two eyebolts

When motors are fitted with two or more eyebolts, all supplied eyebolts must be used simultaneously for the lifting procedure.

There are two possible eyebolt arrangements (vertical and inclined), as shown below:

- For motors with vertical lifting eyebolts, as shown in Figure 4.4, the maximum allowed lifting angle should not exceed 45° in relation to the vertical axis. We recommend to use a spreader beam for maintaining the lifting elements (chain or rope) in vertical position and thus preventing damage to the motor surface;



Figure 4.4 - Maximum resulting angle for motors with two or more lifting eyebolts

- For HGF, W40 and W50 motors, as shown in Figure 4.5, the maximum resulting angle should not exceed 30° in relation to the vertical axis;

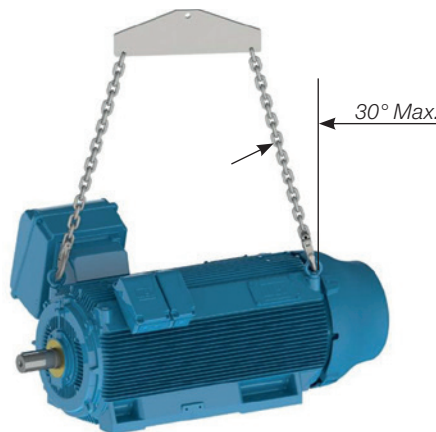

Figure 4.5 - Maximum resulting angle for horizontal HGF, W40 and W50 motors

For W60 motors, as shown in Figure 4.6, the use of a spreader beam is required for maintaining the lifting elements (chain or rope) in vertical position and thus preventing damage to the motor surface.

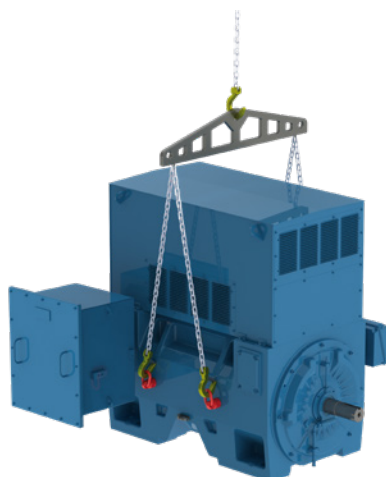

Figure 4.6 - Lifting for W60 motors with paralel chains

- For motors fitted with inclined eyebolts, as shown in Figure 4.7, the use of a spreader beam is required for maintaining the lifting elements (chain or rope) in vertical position and thus preventing damage to the motor surface.



Figure 4.7 - Use of a spreader beam for lifting

4.1.3. Vertical motors

For vertical mounted motors, as shown in Figure 4.8, the use of a spreader beam is required for maintaining the lifting element (chain or rope) in vertical position and thus preventing damage to the motor surface.



Figure 4.8 - Lifting of vertical mounted motors



Always use the eyebolts mounted on the top side of the motor, diametrically opposite, considering the mounting position. See Figure 4.9.



Figure 4.9 - Lifting of HGF and W50 motors.

4.1.3.1. Procedures to place W22 motors in the vertical position

For safety reasons during the transport, vertical mounted Motors are usually packed and supplied in horizontal position.

To place W22 motors fitted with eyebolts (see Figure 4.7), to the vertical position, proceed as follows:

1. Ensure that the eyebolts are tightened properly, as shown in Figure 4.1;
2. Remove the motor from the packaging, using the top mounted eyebolts, as shown in Figure 4.10;



Figure 4.10 - Removing the motor from the packaging

3. Install a second pair of eyebolts, as shown in Figure 4.11;



Figure 4.11 - Installation of the second pair of eyebolts

4. Reduce the load on the first pair of eyebolts to start the motor rotation, as shown in Figure 4.12. This procedure must be carried out slowly and carefully.



Figure 4.12 - End result: motor placed in vertical position

These procedures will help you to move motors designed for vertical mounting. These procedures are also used to place the motor from the horizontal position into the vertical position and vertical to horizontal.

4.1.3.2. Procedures to place HGF and W50 motors in the vertical position

HGF motors are fitted with eight lifting points: four at drive end and four at non-drive end. W50 motors are fitted with nine lifting points: four at drive end, one in the central part and four at non-drive end. The motors are usually transported in horizontal position, however for the installation they must be placed in the vertical position.

To place an these motors in the vertical position, proceed as follows:

1. Lift the motor by using the four lateral eyebolts and two hoists, see Figure 4.13;



Figure 4.13 - Lifting of HGF and W50 motors with two hoists

2. Lower the hoist fixed to motor drive end while lifting the hoist fixed to motor non-drive end until the motor reaches its equilibrium, see Figure 4.14;



Figure 4.14 - Placing HGF and W50 motors in vertical position

3. Remove the hoist hooks from the drive end eyebolts and rotate the motor 180° to fix the removed hooks into the two eyebolts at the motor non-drive end, see Figure 4.15;



Figure 4.15 - Lifting HGF and W50 motors by the eyebolts at the non-drive end

4. Fix the removed hoist hooks in the other two eyebolts at the non-drive end and lift the motor until the vertical position is reached, see Figure 4.16.



Figure 4.16 - HGF and W50 motors in the vertical position

These procedures will help you to move motors designed for vertical mounting. These procedures are also used to place the motor from the horizontal position into the vertical position and vertical to horizontal.

4.2 Procedures to place W22 vertical mount motors in horizontal position

To place W22 vertical mount motor in horizontal position, proceed as follows:

1. Ensure that all eyebolts are tightened properly, as shown in Figure 4.1;
2. Install the first pair of eyebolts and lift the motor as shown in Figure 4.17;



Figure 4.17 - Install the first pair of eyebolts

3. Install the second pair of eyebolts, as shown in Figure 4.18;



Figure 4.18 - Install the second pair of eyebolts

4. Reduce the load on the first pair of eyebolts for rotating the motor, as shown in Figure 4.19. This procedure must be carried out slowly and carefully;



Figure 4.19 - Motor is being rotated to horizontal position

5. Remove the first pair of eyebolts, as shown in Figure 4.20.



Figure 4.20 - Final result: motor placed in horizontal position

5. STORAGE

If the motor is not installed immediately, it must be stored in a dry and clean environment, with relative humidity not exceeding 60%, with an ambient temperature between 5 °C and 40 °C, without sudden temperature changes, free of dust, vibrations, gases or corrosive agents. The motor must be stored in horizontal position, unless specifically designed for vertical operation, without placing objects on it. Do not remove the protection grease from shaft end to prevent rust.

If the motor are fitted with space heaters, they must always be turned on during the storage period or when the installed motor is out of operation. Space heaters will prevent water condensation inside the motor and keep the winding insulation resistance within acceptable levels. Store the motor in such position that the condensed water can be easily drained. If fitted, remove pulleys or couplings from the shaft end (more information are given on item 6).



The space heaters should never be energized when the motor is in operation.

5.1. EXPOSED MACHINED SURFACES

All exposed machined surfaces (like shaft end and flange) are factory-protected with temporary rust inhibitor. A protective film must be reapplied periodically (at least every six months), or when it has been removed and/or damaged.

5.2. STORAGE

The stacking height of the motor packaging during the storage period should not exceed 5 m, always considering the criteria indicated in Table 5.1:

Table 5.1 - Max. recommended stacking height

Packaging type	Frame sizes	Maximum stacking quantity
Cardboard box	IEC 56 to 132 NEMA 143 to 215	Indicated on the top side of the cardboard box
Wood crate	IEC 56 to 315 NEMA 48 to 504/5	06
	IEC 355 NEMA 586/7 and 588/9	03
	W40 / W50 / W60 / HGF IEC 315 to 630 W40 / W50 / HGF NEMA 5000 to 9600	Indicated on the packaging

Notes:

- 1) Never stack larger packaging onto smaller packaging;
- 2) Align the packaging correctly (see Figure 5.1 and Figure 5.2);

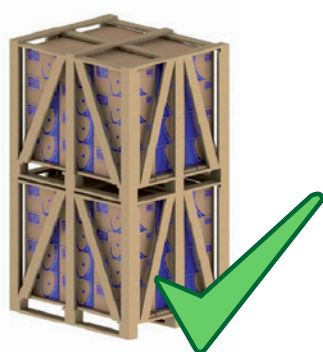

Figure 5.1 - Correct stacking

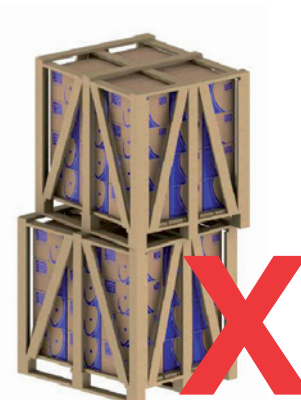

Figure 5.2 - Incorrect stacking

3) The feet of the crates above should always be supported by suitable wood battens (Figure 5.3) and never stand on the steel tape or without support (Figure 5.4);

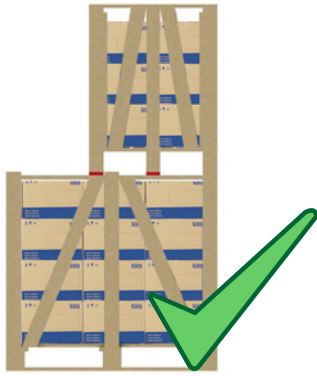

Figure 5.3 - Correct stacking



Figure 5.4 - Incorrect stacking

4) When stacking smaller crates onto longer crates, always ensure that suitable wooden supports are provided to withstand the weight (see Figure 5.5). This condition usually occurs with motor packaging above IEC 225S/M (NEMA 364/5T) frame sizes.



Figure 5.5 - Use of additional battens for stacking

5.3 BEARINGS

5.3.1 Grease lubricated bearings

We recommend rotating the motor shaft at least once a month (by hand, at least five revolutions, stopping the shaft at a different position from the original one). The shaft might not rotate freely in WMagnet and WQuattro motors, due to alignment torque from the magnets. It might be necessary to use a lever.



When rotating the shaft, it is necessary to certify that the terminals are insulated to eliminate the risk of electric shock from induced voltage.

If the motor is fitted with shaft locking device, remove it before rotating the shaft and install it again before performing any handling procedure.

Vertical motors may be stored in the vertical or in horizontal position. If motors with open bearings are stored longer than six months, the bearings must be relubricated according to item 8.2 before commissioning of the motor.

If the motor is stored for longer than 2 years, the bearings must be replaced or removed, washed, inspected and relubricated according to item 8.2.

5.3.2 Oil lubricated bearings

The motor must be stored in its original operating position and with oil in the bearings. Correct oil level must be ensured. It should be in the center of the sight glass.

During the storage period, remove the shaft locking device and rotate the shaft by hand every month, at least five revolutions, thus achieving an even oil distribution inside the bearing and maintaining the bearing in good operating conditions. Reinstall the shaft locking device every time the motor has to be moved.

If the motor is stored for a period equal or longer than the oil change interval, the oil must be replaced according to Item 8.2, before starting the operation. If the motor is stored for a period of over two years, the bearings must be replaced or removed, washed according to manufacturer instructions, checked and relubricated according to Item 8.2. The oil of vertical mounted motors is removed to prevent oils leaks during the transport. After receiving the motor the bearings must be lubricated.

5.3.3 Oil Mist lubricated bearings

The motor must be stored in horizontal position. Lubricate the bearings with ISO VG 68 mineral oil in the amount indicated in the Table 5.2 (this is also valid for bearings with equivalent dimensions). After filling with oil, rotate the shaft by hand, at least five revolutions)

During the storage period, remove the shaft locking device (if any) and rotate the shaft by hand every week, at least five revolutions, stopping it at a different position from the original one. Reinstall the shaft locking device every time the motor has to be moved. If the motor is stored for a period of over two years, the bearings must be replaced or removed, washed according to manufacturer instructions, checked and relubricated according to item 8.2.

Table 5.2 - Amount of oil per bearing

Bearing size	Amount of oil (ml)	Bearing size	Amount of oil (ml)
6201	15	6309	65
6202	15	6311	90
6203	15	6312	105
6204	25	6314	150
6205	25	6315	200
6206	35	6316	250
6207	35	6317	300
6208	40	6319	350
6209	40	6320	400
6211	45	6322	550
6212	50	6324	600
6307	45	6326	650
6308	55	6328	700

The oil must always be removed when the motor has to be handled. If the oil mist system is not operating after installation, fill the bearings with oil to prevent bearing rusting. During the storage period, rotate the shaft by hand, at least five revolutions, stopping it at a different position from the original one. Before starting the motor, all bearing protection oil must be drained from the bearing and the oil mist system must be switched ON.

5.3.4 Sleeve bearing

The motor must be stored in its original operating position and with oil in the bearings. Correct oil level must be ensured. It should be in the middle of the sight glass. During the storage period, remove the shaft locking device and rotate the shaft by hand every month, at least five revolutions, and at 30 rpm, thus achieving an even oil distribution inside the bearing and maintaining the bearing in good operating conditions. Reinstall the shaft locking device every time the motor has to be moved.

If the motor is stored for a period equal or longer than the oil change interval, the oil must be replaced, according to Item 8.2, before starting the operation.

If the motor is stored for a period longer than the oil change interval, or if it is not possible to rotate the motor shaft by hand, the oil must be drained and a corrosion protection and dehumidifiers must be applied.

5.4. INSULATION RESISTANCE

We recommend measuring the winding insulation resistance at regular intervals to follow-up and evaluate its electrical operating conditions. If any reduction in the insulation resistance values are recorded, the storage conditions should be evaluated and corrected, where necessary.

5.4.1. Insulation resistance measurement

We recommend measuring the winding insulation resistance at regular intervals to follow-up and evaluate its electrical operating conditions. If any reduction in the insulation resistance values are recorded, the storage conditions should be evaluated and corrected, where necessary.



The insulation resistance must be measured in a safe environment.

The insulation resistance must be measured with a megohmmeter. The machine must be in cold state and disconnected from the power supply.



To prevent the risk of an electrical shock, ground the terminals before and after each measurement. Ground the capacitor (if any) to ensure that it is fully discharged before the measurement is taken.

It is recommended to insulate and test each phase separately. This procedure allows the comparison of the insulation resistance between each phase. During the test of one phase, the other phases must be grounded. The test of all phases simultaneously evaluates the insulation resistance to ground only but does not evaluate the insulation resistance between the phases.

The power supply cables, switches, capacitors and other external devices connected to the motor may considerably influence the insulation resistance measurement. Thus all external devices must be disconnected and grounded during the insulation resistance measurement.

Measure the insulation resistance one minute after the voltage has been applied to the winding. The applied voltage should be as shown in Table 5.3.

Table 5.3 - Voltage for the insulation resistance

Winding rated voltage (V)	Testing voltage for measuring the insulation resistance (V)
< 1000	500
1000 - 2500	500 - 1000
2501 - 5000	1000 - 2500
5001 - 12000	2500 - 5000
> 12000	5000 - 10000

The reading of the insulation resistance must be corrected to 40 °C as shown in the Table 5.4.

Table 5.4 - Correction factor for the insulation resistance corrected to 40 °C

Measuring temperature of the insulation resistance (°C)	Correction factor of the insulation resistance corrected to 40 °C	Measuring temperature of the insulation resistance (°C)	Correction factor of the insulation resistance corrected to 40 °C
10	0.125	30	0.500
11	0.134	31	0.536
12	0.144	32	0.574
13	0.154	33	0.616
14	0.165	34	0.660
15	0.177	35	0.707
16	0.189	36	0.758
17	0.203	37	0.812
18	0.218	38	0.871
19	0.233	39	0.933
20	0.250	40	1.000
21	0.268	41	1.072
22	0.287	42	1.149
23	0.308	43	1.231
24	0.330	44	1.320
25	0.354	45	1.414
26	0.379	46	1.516
27	0.406	47	1.625
28	0.435	48	1.741
29	0.467	49	1.866
30	0.500	50	2.000

The motor insulation condition must be evaluated by comparing the measured value with the values indicated in Table 5.5 (corrected to 40 °C):

Table 5.5 - Evaluation of the insulation system

Limit value for rated voltage up to 1.1 kV (MΩ)	Limit value for rated voltage above 1.1 kV (MΩ)	Situation
Up to 5	Up to 100	Dangerous. The motor can not be operated in this condition
5 to 100	100 to 500	Regular
100 to 500	Higher than 500	Good
Higher than 500	Higher than 1000	Excellent

The values indicated in the table should be considered only as reference values. It is advisable to log all measured values to provide a quick and easy overview on the machine insulation resistance.

If the insulation resistance is low, moisture may be present in the stator windings. In this case the motor should be removed and transported to a WEG authorized Service Center for proper evaluation and repair (This service is not covered by the warranty). To improve the insulation resistance through the drying process, see section 8.4.



6. INSTALLATION



The insulation resistance must be measured in a safe environment.

Check some aspects before proceeding with the installation:

1. Insulation resistance: must be within the acceptable limits. See item 5.4.
2. Bearings:
If the motor is installed without running immediately, proceed as described in item 5.3.
3. Operating conditions of the start capacitors: If single-phase motors are stored for a period of over two years, it is recommended to change the start capacitors before motor starting since they lose their operating characteristics.
4. Terminal box:
 - a. the inside of the terminal box must be clean and dry;
 - b. the contacts must be correctly connected and corrosion free. See 6.9 and 6.10;
 - c. the cable entries must be correctly sealed and the terminal box cover properly mounted in order to ensure the degree of protection indicated on the motor nameplate.
5. Cooling: the cooling fins, air inlet and outlet openings must be clean and unobstructed. The distance between the air inlet openings and the wall should not be shorter than $\frac{1}{4}$ (one quarter) of the diameter of the air inlet. Ensure sufficient space to perform the cleaning services. See item 7.
6. Coupling: remove the shaft locking device (where fitted) and the corrosion protection grease from the shaft end, including the grounding brush area, and flange immediately before installing the motor. See item 6.4.
7. Drain hole: the motor must always be positioned so the drain hole is at the lowest position (If there is any indication arrow on the drain, the drain must be so installed that the arrow points downwards).
Motors supplied with rubber drain, threaded drain or any other open/close drain plugs must be opened periodically to allow the exit of condensed water. For environments with high water condensation levels and motor with degree of protection IP55, the drain plugs can be mounted in open position (see Figure 6.1). For motors with degree of protection IP56, IP65 or IP66, the drain plugs must remain at closed position (see Figure 6.1), being opened only during the motor maintenance procedures.
The drain system of motors with Oil Mist lubrication system must be connected to a specific collection system (see Figure 6.12).

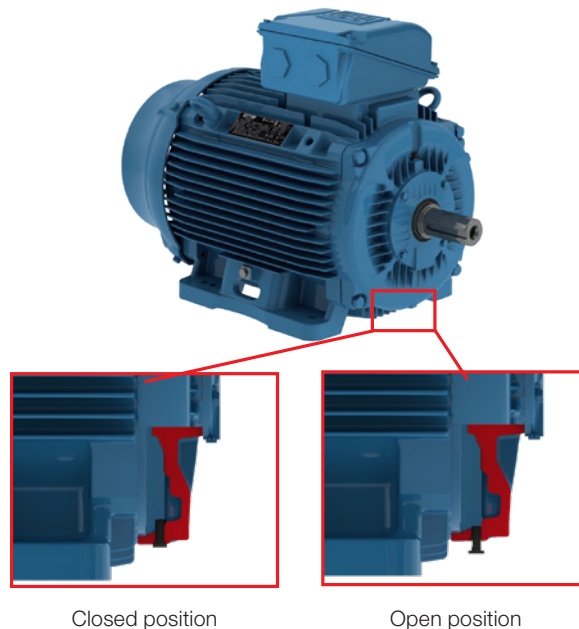

Figure 6.1 - Detail of the rubber drain plug mounted in closed and open position

8. Additional recommendations:

- a. Check the direction of motor rotation, starting the motor at no-load before coupling it to the load;
- b. Vertical mounted motors with shaft end down must be fitted with drip cover to protect them from liquids or solids that may drop onto the motors;
- c. Vertical mounted motors with shaft end up should be fitted with water slinger ring to prevent water ingress inside the motor.
- d. The fixing elements mounted in the threaded through holes in the motor enclosure (for example, the flange) must be properly sealed.



Remove or fix the shaft key before starting the motor.



Changes on the motor construction (features), such as installation of extended grease fittings or modification of the lubrication system, installation of accessories at alternative locations, etc., can be carried out only after prior written consent from WEG.

6.1. FOUNDATIONS

The foundation is the structure, structural element, natural or prepared base, designed to withstand the stresses produced by the installed equipment, ensuring safe and stable performance during operation. The foundation design should consider the adjacent structures to avoid the influences of other installed equipment and no vibration is transferred through the structure

The foundation must be flat and its selection and design must consider the following characteristics:

- a) The features of the machine to be installed on the foundation, the driven loads, application, maximum allowed deformations and vibration levels (for instance, motors with reduced vibration levels, foot flatness, flange concentricity, axial and radial loads, etc. lower than the values specified for standard motors).
- b) Adjacent buildings, conservation status, maximum applied load estimation, type of foundation and fixation and vibrations transmitted by these constructions.

If the motor is supplied with leveling/alignment bolts, this must be considered in the base design.



Please consider for the foundation dimensioning all stresses that are generated during the operation of the driven load.

The user is responsible for the foundation designing and construction.

The foundation stresses can be calculated by using the following equations (see Figure 6.2):

$$F_1 = 0,5 * g * m - (4 * T_b / A)$$

$$F_2 = 0,5 * g * m + (4 * T_b / A)$$

Where:

F_1 and F_2 = lateral stresses (N);

g = gravitational acceleration (9,8 m/s²);

m = motor weight (kg);

T_b = breakdown torque (Nm);

A = distance between centerlines of mounting holes in feet or base of the machine (end view) (m).



The motors may be mounted on:

- Concrete bases: are most used for large-size motors (see Figure 6.2);
- Metallic bases: are generally used for small-size motors (see Figure 6.3).

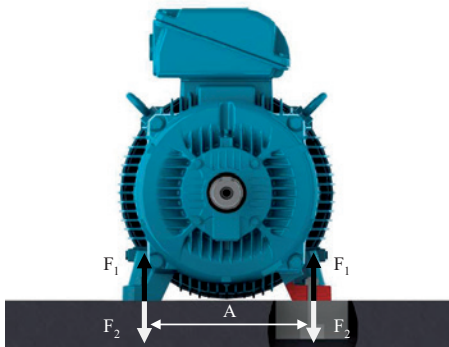

Figure 6.2 - Motor installed on concrete base

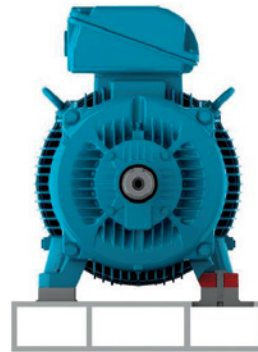

Figure 6.3 - Motor installed on metallic base

The metallic and concrete bases may be fitted with sliding system. These types of foundations are generally used where the power transmission is achieved by belts and pulleys. This power transmission system is easier to assemble/disassemble and allows the belt tension adjustment. Other important aspect of this foundation type is the location of the base locking screws that must be diagonally opposite. The rail nearest the drive pulley is placed in such a way that the positioning bolt is between the motor and the driven machine. The other rail must be placed with the bolt on the opposite side (diagonally opposite), as shown in Figure 6.4 .

To facilitate assembly, the bases may have the following features:

- Shoulders and/or recesses;
- Anchor bolts with loose plates;
- Bolts cast in the concrete;
- Leveling screws;
- Positioning screws;
- Steel & cast iron blocks, plates with flat surfaces.

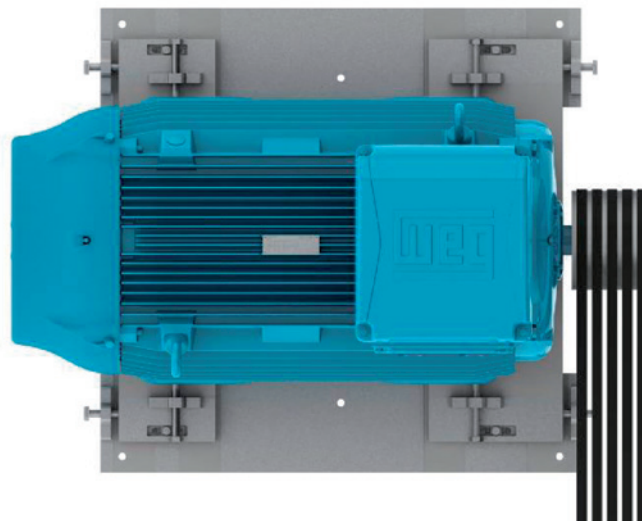



Figure 6.4 - Motor installed on sliding base

After completing the installation, it is recommended that all exposed machined surfaces are coated with suitable rust inhibitor.

6.2. MOTOR MOUNTING

 Footless motors supplied with transportation devices, according to Figure 6.5, must have their devices removed before starting the motor installation.

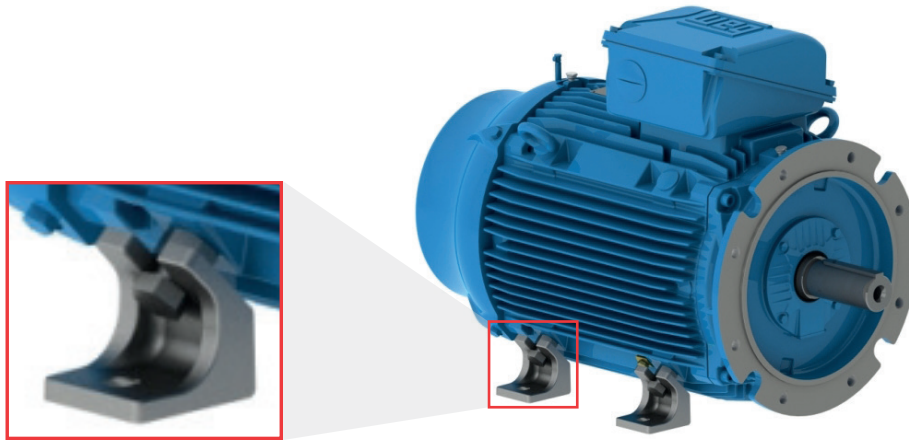

Figure 6.5 - Detail of the transportation devices for footless motors

6.2.1. Foot mounted motors

The drawings of the mounting hole dimensions for NEMA or IEC motors can be checked in the respective technical catalogue.

The motor must be correctly aligned and leveled with the driven machine. Incorrect alignment and leveling may result in bearing damage, generate excessive vibration and even shaft distortion/breakage.

For more details, see section 6.3 and 6.6. The thread engagement length of the mounting bolt should be at least 1.5 times the bolt diameter. This thread engagement length should be evaluated in more severe applications and increased accordingly.

Figure 6.6 shows the mounting system of a foot mounted motor indicating the minimum required thread engagement length.

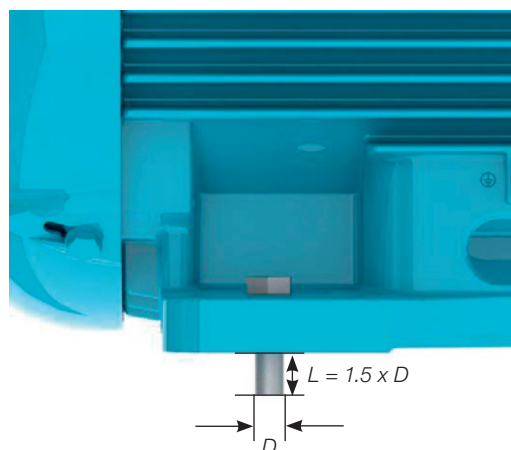

Figure 6.6 - Mounting system of a foot mounted motor

6.2.2. Flange mounted motors

The drawings of the flange mounting dimensions, IEC and NEMA flanges, can be checked in the technical catalogue.

The coupling of the driven equipment to the motor flange must be properly dimensioned to ensure the required concentricity of the assembly.

Depending on the flange type, the mounting can be performed from the motor to the driven equipment flange (flange FF (IEC) or D (NEMA)) or from the driven equipment flange to the motor (flange C (DIN or NEMA)).

For the mounting process from the driven equipment flange to the motor, you must consider the bolt length, flange thickness and the thread depth of the motor flange.

 In cases that use polymer flanges with a built-in nut or the aluminum flange with hexagonal hole, the length of the motor fixing screw must not exceed the length of the hole, thus avoiding misalignment and clearance of the coupling.



If the motor flange has tapped through-holes, the length of the mounting bolts must not exceed the tapped through-hole length of the motor flange, thus preventing damage to the winding head.

For flange mounting the thread engagement length of the mounting bolt should be at least 1.5 times the bolt diameter. In severe applications, longer thread engagement length may be required.

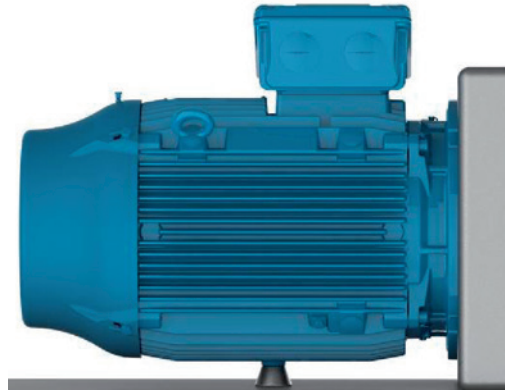

Figure 6.7 - Mounting method of flange mounted motors with frame base support

In severe applications or if large motors are flange mounted, a foot or pad mounting may be required in addition to the flange mounting (Figure 6.7). The motor must never be supported on its cooling fins.

For W12 motors, do not exceed the maximum tightening torque of 8 Nm when fixing the foot and/or polymeric flange on the equipment.

When the motor is used in vertical shaft up position, fixed by foot, the foot must be locked axially by the fixing of a flat socket head screw M5x0.8 measuring 16mm length (W63 and W71) or 12mm length (IEC56).

The hexagonal holes of the C-80 and C-105 flanges of W12 motors are suitable for M5 (maximum torque 5 Nm) and M6 (maximum torque 8 Nm) screws, respectively.

Note:

When liquid (for example oil) is likely to come into contact with the shaft seal, please contact your local WEG representative.

6.2.3. Pad mounted motors

Typically, this method of mounting is used in axial fans. The motor is fixed by tapped holes in the frame. The dimensions of these tapped holes can be checked in the respective product catalogue. The selection of the motor mounting rods/bolts must consider the dimensions of the fan case, the installation base and the thread depth in the motor frame.

The mounting rods and the fan case wall must be sufficiently stiff to prevent the transmission of excessive vibration to the machine set (motor & fan). Figure 6.8 shows the pad mounting system.

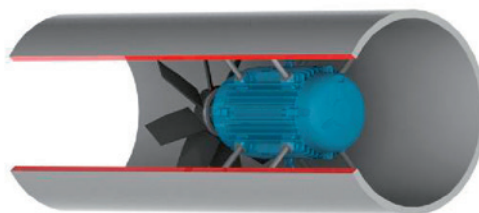

Figure 6.8 - Mounting of the motor inside the cooling duct

6.3. BALANCING

Unbalanced machines generate vibration which can result in damage to the motor. WEG motors are dynamically balanced with “half key” and without load (uncoupled). Special balancing quality level must be stated in the Purchase Order.



The transmission elements, such as pulleys, couplings, etc., must be balanced with “half key” before they are mounted on the motor shaft.

The balance quality grade meets the applicable standards for each product line.

The maximum balancing deviation must be recorded in the installation report.

6.4. COUPLINGS

Couplings are used to transmit the torque from the motor shaft to the shaft of the driven machine. The following aspects must be considered when couplings are installed:

- Use proper tools for coupling assembly & disassembly to avoid damages to the motor and bearings;
- Whenever possible, use flexible couplings, since they can absorb eventual residual misalignments during the machine operation;
- The maximum loads and speed limits informed in the coupling and motor manufacturer catalogues cannot be exceeded;
- Level and align the motor as specified in sections 6.5 and 6.6, respectively.



Remove or fix the shaft key firmly when the motor is operated without coupling in order to prevent accidents.

6.4.1. Direct coupling

Direct coupling is characterized when the Motor shaft is directly coupled to the shaft of the driven machine without transmission elements. Whenever possible, use direct coupling due to lower cost, less space required for installation and more safety against accidents.



Do not use roller bearings for direct coupling, unless sufficient radial load is expected.

6.4.2. Gearbox coupling

Gearbox coupling is typically used where speed reduction is required.

Make sure that shafts are perfectly aligned and strictly parallel (in case of straight spur gears) and in the right meshing angle (in case of bevel and helical gears).

6.4.3. Pulley and belt coupling

Pulleys and belts are used when speed increase or reduction between motor shaft and driven load is required.



Excessive belt tension will damage the bearings and cause unexpected accidents such as breakage of the motor shaft.

6.4.4. Coupling of sleeve bearing motors



Motors designed with sleeve bearings must be operated with direct coupling to the driven machine or a gearbox. Pulley and belts can not be applied for sleeve bearing motors.

Motors designed with sleeve bearings have 3 (three) marks on the shaft end. The center mark is the indication of the magnetic center and the 2 (two) outside marks indicate the allowed limits of the rotor axial movement, as shown in Figure 6.9.

The motor must be so coupled that during operation the arrow on the frame is placed over the central mark indicating the rotor magnetic center. During start-up, or even during operation, the rotor may freely move between the two outside marks when the driven machine exerts an axial load on the motor shaft. However, under no circumstance, the motor can operate continuously with axial forces on the bearing.

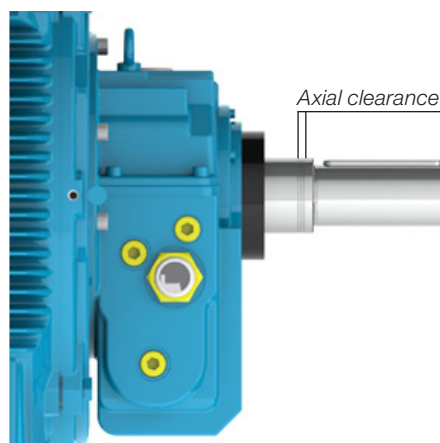

Figure 6.9 - Axial clearance of motor designed with sleeve bearing



For coupling evaluation consider the maximum axial bearing clearance as shown in Table 6.1. The axial clearance of the driven machine and coupling influence the maximum bearing clearance.

Table 6.1 - Clearance used for sleeve bearings

Bearing size	Total axial clearance (mm)
9*	3 + 3 = 6
11*	4 + 4 = 8
14*	5 + 5 = 10
18	7,5 + 7,5 = 15

* For Motors in accordance with API 541, the total axial clearance is 12.7 mm

The sleeve bearings used by WEG were not designed to support axial load continuously. Under no circumstance must the motor be operated continuously at its axial clearance limits.

6.5. LEVELING

The motor must be leveled to correct any deviations in flatness arising from the manufacturing process and the material structure rearrangement. The leveling can be carried out by a leveling screw fixed on the motor foot or on the flange or by means of thin compensation shims. After the leveling process, the leveling height between the motor mounting base and the motor cannot exceed 0.1 mm.

If a metallic base is used to level the height of the motor shaft end and the shaft end of the driven machine, level only the metallic base relating to the concrete base.

Record the maximum leveling deviations in the installation report.

6.6. ALIGNMENT

The correct alignment between the motor and the driven machine is one of the most important variables that extends the useful service life of the motor. Incorrect coupling alignment generates high loads and vibrations reducing the useful life of the bearings and even resulting in shaft breakages. Figure 6.10 illustrates the misalignment between the motor and the driven machine.

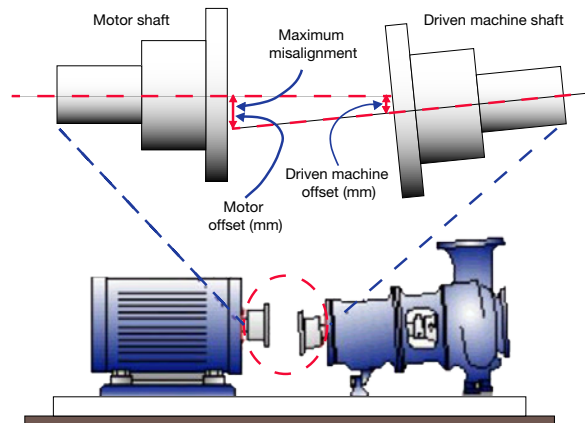

Figure 6.10 - Typical misalignment condition

Alignment procedures must be carried out using suitable tools and devices, such as dial gauge, laser alignment instruments, etc.. The motor shaft must be aligned axially and radially with the driven machine shaft.

The maximum allowed eccentricity for a complete shaft turn should not exceed 0.03 mm, when alignment is made with dial gauges, as shown in Figure 6.11. Ensure a gap between couplings to compensate the thermal expansion between the shafts as specified by the coupling manufacturer.

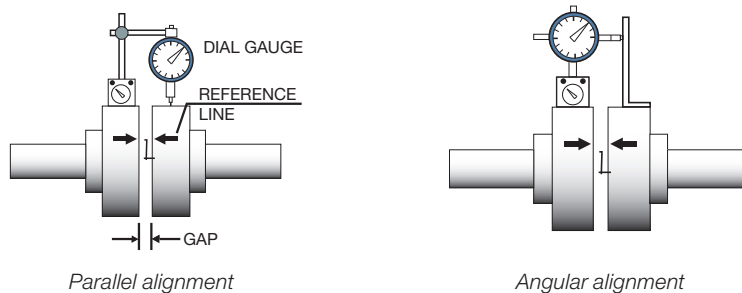

Figure 6.11 - Alignment with dial gauge

If alignment is made by a laser instrument, please consider the instructions and recommendations provided by the laser instrument manufacturer.

The alignment should be checked at ambient temperature with machine at operating temperature.



The coupling alignment must be checked periodically.

Pulley and belt couplings must be so aligned that the driver pulley center lies in the same plane of the driven pulley center and the motor shaft and the shaft of the driven machine are perfectly parallel.

After completing the alignment procedures, ensure that mounting devices do not change the motor and machine alignment and leveling resulting into machine damage during operation.

It is recommended to record the maximum alignment deviation in the Installation Report.

6.7. CONNECTION OF OIL LUBRICATED OR OIL MIST LUBRICATED MOTORS

When oil lubricated or oil mist lubricated motors are installed, connect the existing lubricant tubes (oil inlet and oil outlet tubes and motor drain tube), as shown in Figure 6.12. The lubrication system must ensure continuous oil flow through the bearings as specified by the manufacturer of the installed lubrication system.

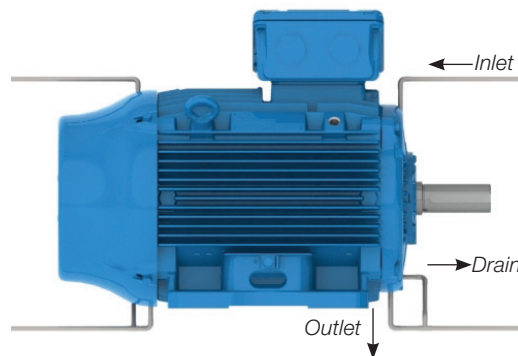

Figure 6.12 - Oil supply and drain system of oil lubricated or oil mist lubricated motors

6.8. CONNECTION OF THE COOLING WATER SYSTEM

When water cooled motors are installed, connect the water inlet and outlet tubes to ensure proper motor cooling. According to item 7.2, ensure correct cooling water flow rate and water temperature in the motor cooling system.

6.9. ELECTRICAL CONNECTION

Consider the rated motor current, service factor, starting current, environmental and installation conditions, maximum voltage drop, etc. to select appropriate power supply cables and switching and protection devices. All motors must be installed with overload protection systems. Three-phase motors should be fitted with phase fault protection systems.



Before connecting the motor, check if the power supply voltage and the frequency comply with the motor nameplate data. All wiring must be made according to the connection diagram on the motor nameplate. Please consider the connection diagrams in the Tables 6.2 and 6.3 as reference value.

To prevent accidents, check if motor has been solidly grounded in accordance with the applicable standards.



Table 6.2 - Typical connection diagram for three-phase motors.

Configuration	Quantity of leads	Type of connection	Connection diagram																							
Single speed	3	-																								
	6	Δ - Y																								
	9	YY - Y																								
		$\Delta\Delta$ - Δ																								
	12	$\Delta\Delta$ - YY - Δ - Y																								
	Δ - PWS Part-winding start	<table border="0"> <tr> <td colspan="3">PART-WINDING</td> <td colspan="3">WYE-DELTA</td> </tr> <tr> <td>START</td> <td>RUN</td> <td></td> <td>START</td> <td>RUN</td> <td></td> </tr> <tr> <td></td> <td></td> <td></td> <td></td> <td></td> <td></td> </tr> <tr> <td>L1 L2 L3</td> <td>L1 L2 L3</td> <td></td> <td>L1 L2 L3</td> <td>L1 L2 L3</td> <td></td> </tr> </table>	PART-WINDING			WYE-DELTA			START	RUN		START	RUN								L1 L2 L3	L1 L2 L3		L1 L2 L3	L1 L2 L3	
PART-WINDING			WYE-DELTA																							
START	RUN		START	RUN																						
L1 L2 L3	L1 L2 L3		L1 L2 L3	L1 L2 L3																						
Double speed Dahlander	6	YY - Y Variable Torque																								
		Δ - YY Constant Torque																								
		YY - Δ Constant Output																								
	9	Δ - Y - YY																								
Double speed Double winding	6	-																								

Equivalent table for lead identification

Lead identification on the wiring diagram		1	2	3	4	5	6	7	8	9	10	11	12
Single speed	NEMA MG 1 Part 2	T1	T2	T3	T4	T5	T6	T7	T8	T9	T10	T11	T12
	IEC 60034-8	U1	V1	W1	U2	V2	W2	U3	V3	W3	U4	V4	W4
Double speed (Dahlander / Double winding)	NEMA MG 1 Part 2 ¹⁾	1U	1V	1W	2U	2V	2W	3U	3V	3W	4U	4V	4W
	IEC 60034-8	1U	1V	1W	2U	2V	2W	3U	3V	3W	4U	4V	4W

1) NEMA MG 1 Part 2 defines T1 to T12 for two or more winding, however WEG adopts 1U to 4W.

Table 6.3 - Typical connection diagram for single-phase motors.

Voltage	Direction of Rotation	Thermal Protection	Type	Connection diagram	
Single	CW or CCW	With or Without	Run / Permanent Capacitors Two values		
				Without	
	Phenolic Thermal Protector				
	Thermostat				
Double	CW or CCW	Without	Run / Permanent Capacitors Two values or Split Phase		
		Phenolic Thermal Protector			
		Thermostat			
	Both	Without	Split Phase (without capacitor)	Run / Permanent Capacitors Two values	
			Run / Permanent Capacitors Two values		
		Phenolic Thermal Protector	Split Phase (without capacitor)	Run / Permanent Capacitors Two values	
			Run / Permanent Capacitors Two values		
			Split Phase (without capacitor)		
		Thermostat	Split Phase (without capacitor)	Run / Permanent Capacitors Two values	
			Run / Permanent Capacitors Two values		

ENGLISH



W12 platform motors with polymeric terminal box cover have the connection diagram printed on its interior. To connect the cables, check on the nameplate the diagram code that must be used.



WARNING - Local Standards have priority on the definition of the connection standards.

The connections presented below are a reference for the connection of the customer's power cables on low voltage motors with terminal block. The terminal blocks presented below are the standard for each product line, however variations may occur. It is recommended the use of terminals made of electrolytic copper or brass, similar to the terminals used on the motors cables.

W21 and W22

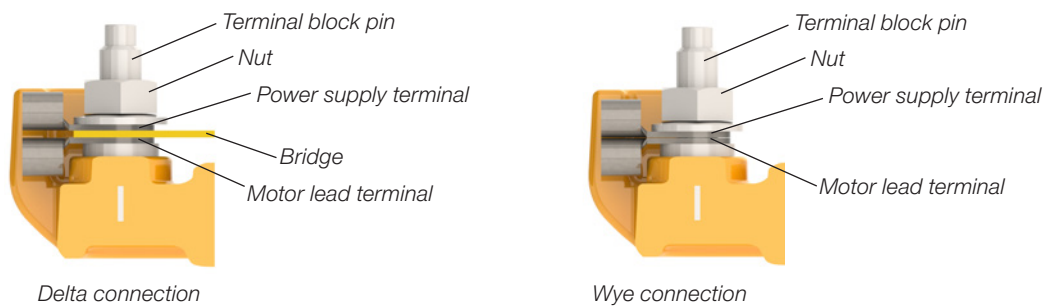

Figure 6.13 - Connection for W21 and W22 motors with terminal block

HGF, W40, W50 and W60

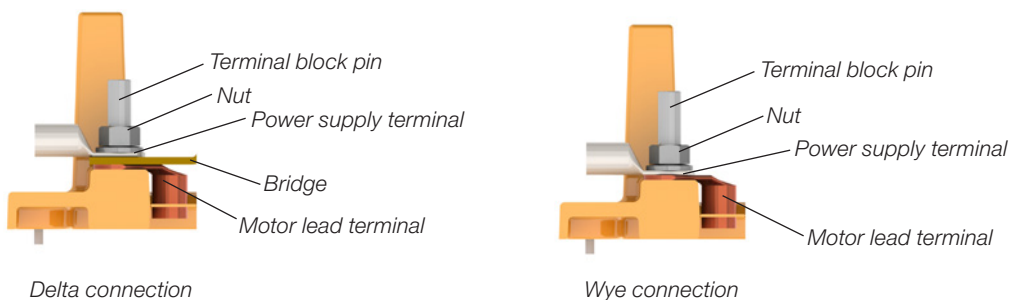

Figure 6.14 - Connection for HGF, W40, W50 and W60 motors with terminal block

If motors are supplied without terminal blocks, insulate the cable terminals with suitable insulation material that meets the power supply voltage and the insulation class indicated on the motor nameplate.

Ensure correct tightening torque for the power cable and grounding connections as specified in Table 8.12.

The clearance distance (see Figure 6.15) between non-insulated live parts with each other and between grounded parts must be as indicated in Table 6.4.

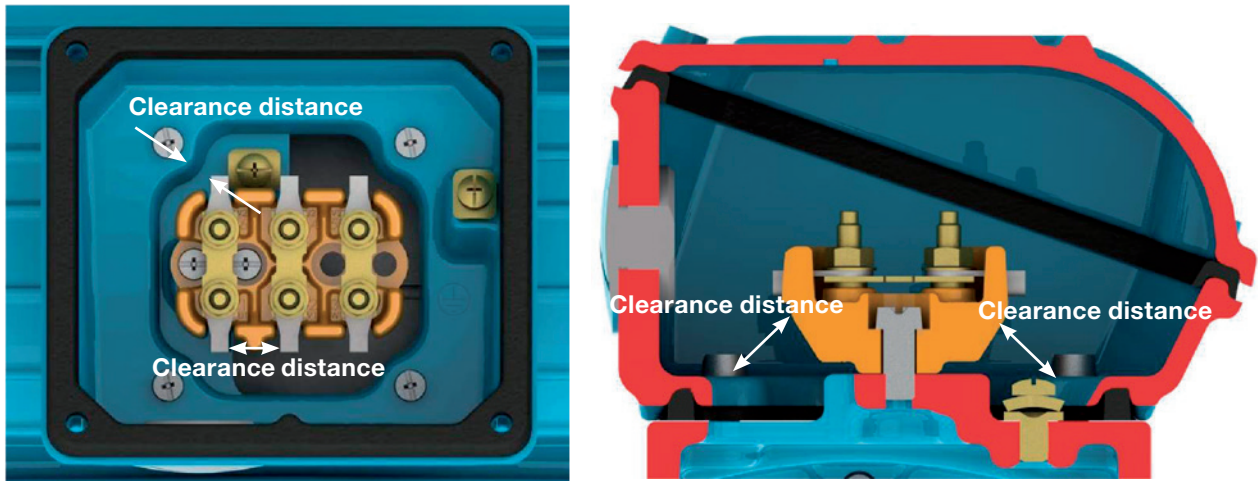

Figure 6.15 - Clearance distance representation

Table 6.4 - Minimum clearance distance (mm) x supply voltage

Voltage	Minimum clearance distance (mm)
$U \leq 440 \text{ V}$	4
$440 < U \leq 690 \text{ V}$	5.5
$690 < U \leq 1000 \text{ V}$	8
$1000 < U \leq 6900 \text{ V}$	45
$6900 < U \leq 11000 \text{ V}$	70
$11000 < U \leq 16500 \text{ V}$	105



Even when the motor is off, dangerous voltages may be present inside the terminal box used for the space heater supply or winding energization when the winding is used as heating element. Motor capacitors will hold a charge even after the power has been cut off. Do not touch the capacitors and/or motor terminals, before discharging the capacitors completely. For WMagnet and WQuattro motors, even when the motor is disconnected from the power supply, there may be voltage in the motor's terminals if the rotor moves.



After the motor connection has been completed, ensure that no tool or foreign body has been left inside the terminal box.



Take the required measures in order to ensure the degree of protection indicated on the motor nameplate:

- unused cable inlet holes in the terminal boxes must be properly closed with threaded blanking plugs;
- components supplied loose (for example, terminal boxes mounted separately) must be properly closed and sealed.

The cable inlets used for power supply and control must be fitted with components (for example, cable-glands and conduits) that meet the applicable standards and regulations in each country.



If the motor is fitted with accessories, such as brakes and forced cooling systems, these devices must be connected to the power supply according to the information provided on their nameplates and with special care as indicated above.



In motors with polymeric terminal box and/or its cover, ensure that the fittings and locks of these components are correctly assembled after performing the cable connection.

All protection devices, including overcurrent protection, must be set according to the rated machine conditions. These protection devices must protect the machine against short circuit, phase fault or locked rotor condition. The motor protection devices must be set according to the applicable standards.

Check the direction of rotation of the motor shaft. If there is no limitation for the use of unidirectional fans, the shaft rotation direction can be changed by reversing any two of the phase connections. For single-phase motor, check the connection diagram indicated on the motor nameplate.

6.10. CONNECTION OF THE THERMAL PROTECTION DEVICES

If the motor is supplied with temperature monitoring devices, such as, thermostat, thermistors, automatic thermal protectors, Pt-100 (RTD), etc., they must be connected to the corresponding control devices as specified on the accessory nameplates. The non-compliance with this procedure may void the product warranty and cause serious material damages.



Do not apply test voltage above 2.5 V on thermistors and current above 1 mA on RTDs (Pt-100) according to IEC 60751 standard.

Figure 6.16 and Figure 6.17 show the connection diagram of the bimetal thermal protector (thermostats) and thermistors, respectively.

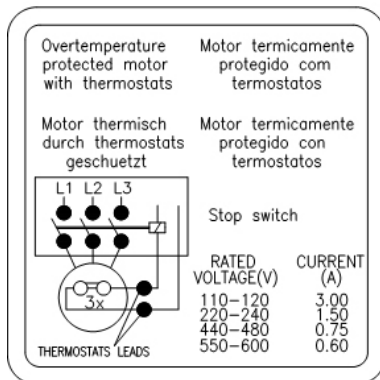

Figure 6.16 - Connection of the bimetal thermal protectors (thermostats)

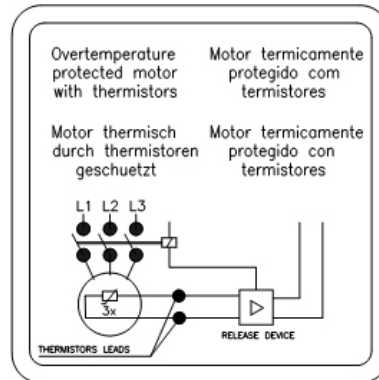

Figure 6.17 - Thermistor connection

The alarm temperature limits and thermal protection shutdowns can be defined according to the application; however these temperature limits can not exceed the values in Table 6.5.

Table 6.5 - Maximum activation temperature of the thermal protections

Component	Insulation class	Maximum temperature of the protection setting (°C)	
		Alarm	Tripping
Winding	B	-	130
	F	130	155
	H	155	180
Bearing	All	110	120

Notes:

- 1) The number and type of the installed protection devices are stated on the accessory nameplate of the motor.
- 2) If the motor is supplied with calibrated resistance, (for example, Pt-100), the motor protection system must be set according to the operating temperatures indicated in Table 6.5.

6.11. RESISTANCE TEMPERATURE DETECTORS (PT-100)

The thermocouples Pt-100 are made of materials, whose resistance depends on the temperature variation, intrinsic property of some materials (usually platinum, nickel or copper), calibrated resistance. Its operation is based on the principle that the electric resistance of a metallic conductor varies linearly with the temperature, thus allowing a continuous monitoring of the motor warm-up through the controller display ensuring a high level of precision and answer stability. These devices are widely used for measuring temperatures in various industry sectors.

In general these devices are used in installations where precise temperature control is required, for example, in installation for irregular or intermittent duty. The same detector may be used for alarm and tripping purposes. Table 6.6 and Figure 6.19 show the equivalence between the Pt-100 resistance and the temperature. The Figure 6.18 shows the connection of a winding Pt-100.

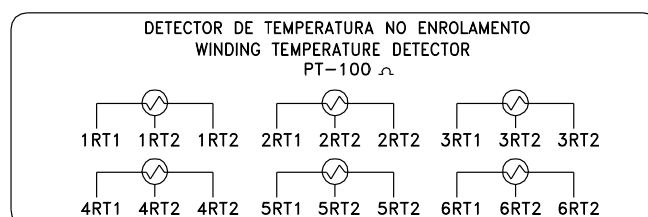

Figure 6.18 - Connection of winding Pt-100

Table 6.6 - Equivalence between the Pt-100 resistance and the temperature

°C	Ω	°C	Ω	°C	Ω	°C	Ω	°C	Ω
-29	88.617	17	106.627	63	124.390	109	141.908	155	159.180
-28	89.011	18	107.016	64	124.774	110	142.286	156	159.553
-27	89.405	19	107.404	65	125.157	111	142.664	157	159.926
-26	89.799	20	107.793	66	125.540	112	143.042	158	160.298
-25	90.193	21	108.181	67	125.923	113	143.420	159	160.671
-24	90.587	22	108.570	68	126.306	114	143.797	160	161.043
-23	90.980	23	108.958	69	126.689	115	144.175	161	161.415
-22	91.374	24	109.346	70	127.072	116	144.552	162	161.787
-21	91.767	25	109.734	71	127.454	117	144.930	163	162.159
-20	92.160	26	110.122	72	127.837	118	145.307	164	162.531
-19	92.553	27	110.509	73	128.219	119	145.684	165	162.903
-18	92.946	28	110.897	74	128.602	120	146.061	166	163.274
-17	93.339	29	111.284	75	128.984	121	146.438	167	163.646
-16	93.732	30	111.672	76	129.366	122	146.814	168	164.017
-15	94.125	31	112.059	77	129.748	123	147.191	169	164.388
-14	94.517	32	112.446	78	130.130	124	147.567	170	164.760
-13	94.910	33	112.833	79	130.511	125	147.944	171	165.131
-12	95.302	34	113.220	80	130.893	126	148.320	172	165.501
-11	95.694	35	113.607	81	131.274	127	148.696	173	165.872
-10	96.086	36	113.994	82	131.656	128	149.072	174	166.243
-9	96.478	37	114.380	83	132.037	129	149.448	175	166.613
-8	96.870	38	114.767	84	132.418	130	149.824	176	166.984
-7	97.262	39	115.153	85	132.799	131	150.199	177	167.354
-6	97.653	40	115.539	86	133.180	132	150.575	178	167.724
-5	98.045	41	115.925	87	133.561	133	150.950	179	168.095
-4	98.436	42	116.311	88	133.941	134	151.326	180	168.465
-3	98.827	43	116.697	89	134.322	135	151.701	181	168.834
-2	99.218	44	117.083	90	134.702	136	152.076	182	169.204
-1	99.609	45	117.469	91	135.083	137	152.451	183	169.574
0	100.000	46	117.854	92	135.463	138	152.826	184	169.943
1	100.391	47	118.240	93	135.843	139	153.200	185	170.313
2	100.781	48	118.625	94	136.223	140	153.575	186	170.682
3	101.172	49	119.010	95	136.603	141	153.950	187	171.051
4	101.562	50	119.395	96	136.982	142	154.324	188	171.420
5	101.953	51	119.780	97	137.362	143	154.698	189	171.789
6	102.343	52	120.165	98	137.741	144	155.072	190	172.158
7	102.733	53	120.550	99	138.121	145	155.446	191	172.527
8	103.123	54	120.934	100	138.500	146	155.820	192	172.895
9	103.513	55	121.319	101	138.879	147	156.194	193	173.264
10	103.902	56	121.703	102	139.258	148	156.568	194	173.632
11	104.292	57	122.087	103	139.637	149	156.941	195	174.000
12	104.681	58	122.471	104	140.016	150	157.315	196	174.368
13	105.071	59	122.855	105	140.395	151	157.688	197	174.736
14	105.460	60	123.239	106	140.773	152	158.061	198	175.104
15	105.849	61	123.623	107	141.152	153	158.435	199	175.472
16	106.238	62	124.007	108	141.530	154	158.808	200	175.840

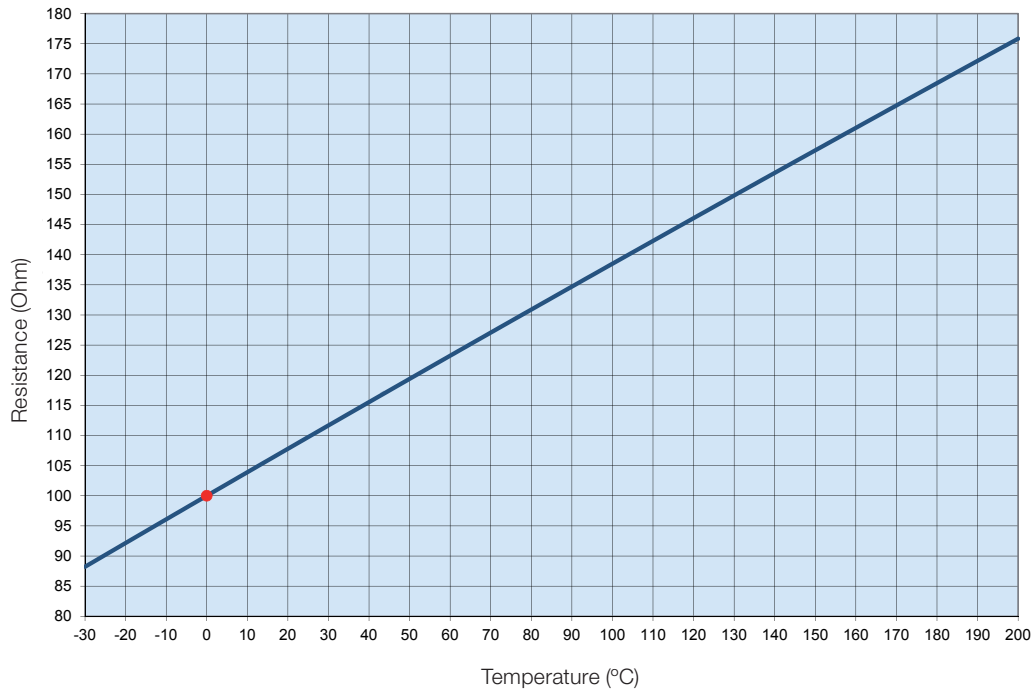

Figure 6.19 - Ohmic resistance of the Pt-100 x temperature

6.12. CONNECTION OF THE SPACE HEATERS

Before switching ON the space heaters, check if the space heaters connection have been made according to the connection diagram shown on the space heater nameplate. For motors supplied with dual voltage space heaters (110-127/220-240 V), see Figure 6.20.

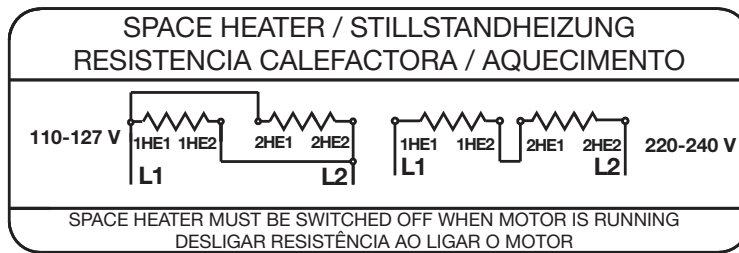

Figure 6.20 - Dual voltage space heater connection



The space heaters should never be energized when the motor is in operation.

6.13. STARTING METHODS

Whenever possible, the motor starting must be Direct On Line (DOL) at rated voltage. This is the most simple and feasible starting method. However, it must only be applied when the starting current does not affect the power supply. Please consider the local electric utility regulations when installing a motor.

High inrush current may result in:

- a) high voltage drop in the power supply line creating unacceptable line disturbance on the distribution system;
- b) requiring oversized protection system (cables and contactor) increasing the installation costs.

If DOL starting is not allowed due to the reasons mentioned above, an indirect starting method compatible with the load and motor voltage to reduce the starting current may be used.

If reduced voltage starters are used for starting, the motor starting torque will also be reduced.

Table 6.7 shows the possible indirect starting methods that can be used depending on the number of the motor leads.

Table 6.7 - Starting method x number of motor leads

Number of leads	Possible starting methods
3 leads	Autotransformer Soft-starter
6 leads	Star-Delta Autotransformer Soft-starter
9 leads	Series/Parallel Part winding Autotransformer Soft-starter
12 leads	Star-Delta Series/Parallel Part winding Autotransformer Soft-starter

Table 6.8 shows examples of possible indirect starting methods to be used according to the voltage indicated on the motor nameplate and the power supply voltage.

Table 6.8 - Starting methods x voltage

Nameplate voltage	Operating voltage	Star-delta	Autotransformer starting	Starting by series/parallel switch	Part-winding starting	Starting by Soft-starter
220/380 V	220 V	YES	YES	NO	NO	YES
	380 V	NO	YES	NO	NO	YES
220/440 V	220 V	NO	YES	YES	YES	YES
	440 V	NO	YES	NO	NO	YES
230/460 V	230 V	NO	YES	YES	YES	YES
	460 V	NO	YES	NO	NO	YES
380/660 V	380 V	YES	YES	NO	NO	YES
220/380/440 V	220 V	YES	YES	YES	YES	YES
	380 V	NO	YES	YES	YES	YES
	440 V	YES	YES	NO	NO	YES

6.14. MOTORS DRIVEN BY FREQUENCY INVERTER



The operation with frequency inverter must be stated in the Purchase Order since this drive type may require some changes of the motor design.



WMagnet Motors must only be driven by frequency inverter. The WQuattro line motors must be started direct on-line (DOL) or driven by a frequency inverter in scalar mode.

The frequency inverter used to drive motors up to 690 V must be fitted with Pulse With Modulation (PWM) with vector control.

When a motor is driven by a frequency inverter at lower frequencies than the rated frequency, you must reduce the motor torque to prevent motor overheating. The torque reduction (derating torque) can be found in the item 6.4 of the “Technical Guidelines for Induction Motors driven by PWM Frequency inverters” available on the site www.weg.net.

If the motor is operated above the rated frequency, please note:

- That the motor must be operated at constant output;
- That the motor can supply max. 95% of its rated output;
- Do not exceed the maximum speed and please consider:
 - max. operating frequency stated on the additional nameplate;
 - mechanical speed limitation of the motor.

For WMagnet motors driven by non-WEG inverters, in addition to the speed limit stated in the motor data sheet, the maximum permitted speed limit must be checked to avoid burning the inverter in the event of a power failure. It should be considered according to the equation below:

$$RPM_{max} = \frac{0.9 * V_{rmsMax} * 1000}{ke}$$

Being,

RPM_{max} – Maximum speed allowed to avoid burning the inverter in the event of a power failure in [RPM].

V_{rmsMax} – Maximum input rms voltage of the inverter, as informed by the inverter manufacturer in [V].

ke – Parameter informed on the nameplate and in the motor data sheet in [V / kRPM].

Information on the selection of the power cables between the frequency inverter and the motor can be found in the item 6.4 of the “Technical Guidelines for Induction Motors driven by PWM Frequency inverters” available at www.weg.net.

6.14.1. Use of dV/dt filter

6.14.1.1. Motor with enameled round wire

Motors designed for rated voltages up to 690 V, when driven by frequency inverter, do not require the use of dV/dT filters, provided they comply with the criteria in Table 6.9.

Table 6.9 - Criteria for the selection of motors with round enameled wire when driven by frequency inverter

Motor rated voltage ¹	Peak voltage at the motor terminals (max)	dV/dt inverter output (max)	Inverter Rise Time ² (min.)	MTBP ² Time between pulses (min)
Vnom < 460 V	≤ 1600 V	≤ 5200 V/μs	≥ 0,1 μs	≥ 6 μs
460 ≤ Vnom < 575 V	≤ 2000 V	≤ 6500 V/μs		
575 ≤ Vnom ≤ 1000 V	≤ 2400 V	≤ 7800 V/μs		

Notes:

1. For the application of dual voltage motors, example 380/660 V, consider the lower voltage (380 V).

2. Information supplied by the inverter manufacturer.

6.14.1.2. Motor with prewound coils

Motors with prewound coils (medium and high voltage motors regardless of frame sizes, and low voltage motors from IEC 500 / NEMA 800 frame on), designed for the use with frequency inverters, do not require the use of filters, provided they comply with the criteria in Table 6.10.

Table 6.10 - Criteria to be considered when using motor with prewound coils to be drive by frequency inverters

Motor rated voltage	Type of modulation	Turn to turn insulation (phase-phase)		Phase-ground insulation	
		Peak voltage at the motor terminals	dV/dt at the motor terminals	Peak voltage at the motor terminals	dV/dt at the motor terminals
690 < Vnom ≤ 4160 V	Sinusoidal	≤ 5900 V	≤ 500 V/μs	≤ 3400 V	≤ 500 V/μs
	PWM	≤ 9300 V	≤ 2700 V/μs	≤ 5400 V	≤ 2700 V/μs
4160 < Vnom ≤ 6600 V	Sinusoidal	≤ 9300 V	≤ 500 V/μs	≤ 5400 V	≤ 500 V/μs
	PWM	≤ 14000 V	≤ 1500 V/μs	≤ 8000 V	≤ 1500 V/μs

6.14.2. Bearing insulation

Only the motors in IEC frame size 315 (NEMA 50) and larger are supplied, as standard, with insulated bearing. If motor must be driven by frequency inverter, insulate the bearing according to Table 6.11.

Table 6.11 - Recommendation on the bearing insulation for inverter driven motors

Frame size	Recommendation
IEC 315 and 355 NEMA 445/7 to L5810/11	<ul style="list-style-type: none"> ■ Insulated bearing/end shield ■ Grounding between shaft and frame by grounding brush
IEC 400 and larger NEMA 680 and larger	<ul style="list-style-type: none"> ■ Insulated NDE bearing ■ Grounding between shaft and frame by grounding brush

 When motors are supplied with shaft grounding system, monitor the grounding brush constantly during its operation and, when it reaches the end of its useful life, it must be replaced by another brush with the same specification.

6.14.3. Switching frequency

The minimum inverter switching frequency must not be lower than 2 kHz and should not exceed 5 kHz.

 The non-compliance with the criteria and recommendations indicated in this manual may void the product warranty.

6.14.4. Mechanical speed limitation

Table 6.12 shows the maximum speeds allowed for motors driven by frequency inverter. For WMagnet motors, see the motor's data sheet or contact WEG.

Table 6.12 - Maximum motor speed (in rpm)

Frame size		DE-bearing	Maximum speed for standard motors
IEC	NEMA		
63-90	143/5	6201	10400
		6202	
		6203	
		6204	
		6205	
100	-	6206	8800
112	182/4	6207	7600
		6307	6800
132	213/5	6308	6000
160	254/6	6309	5300
180	284/6	6311	4400
225-630	364/5-9610	6312	4200
		6314	3600
		6315	3600
		6316	3200
		6218	3600
		6319	3000
		6220	3600
		6320	2200
		6322	1900
		6324	1800
		6328	1800
		6330	1800
		6224	1800
		6228	1800

Note:
To select the maximum allowed motor speed, consider the motor torque derating curve.

For more information on the application of frequency inverters, contact WEG or check the “Technical Guidelines for Induction Motors driven by PWM Frequency inverters” available at www.weg.net.

7. COMMISSIONING

7.1. INITIAL START-UP

After finishing the installation procedures and before starting the motor for the first time or after a long period without operation, the following items must be checked:

- If the nameplate data (voltage, current, connection diagram, degree of protection, cooling system, service factor, etc.) meet the application requirements;
- If the machine set (motor + driven machine) has been mounted and aligned correctly;
- If the motor driving system ensures that the motor speed does not exceed the max. allowed speed indicated in Table 6.12;
- Measure the winding insulation resistance, making sure it complies with the specified values in item 5.4;
- Check the motor rotation direction;
- Inspect the motor terminal box for damage and ensure that it is clean and dry and all contacts are rust-free, the seals are in perfect operating conditions and all unused threaded holes are properly closed thus ensuring the degree of protection indicated on the motor nameplate;
- Check if the motor wiring connections, including grounding and auxiliary equipment connection, have been carried out properly and are in accordance with the recommendations in item 6.9;
- Check the operating conditions of the installed auxiliary devices (brake, encoder, thermal protection device, forced cooling system, etc.);
- Check bearing operating conditions. If the motors are stored and/or installed for more than two years without running, it is recommended to change the bearings, or to remove, wash, inspect and relubricate them before the motor is started. If the motor is stored and/or installed according to the recommendations described in item 5.3, lubricate the bearings as described in item 8.2. For the bearing condition evaluation, it is recommended to use of the vibration analysis techniques: Envelope Analysis or Demodulation Analysis.
- For roller bearing motors with oil lubrication, ensure:
 - The oil level should be in the center of the sight glass (see Figure 8.1 and 8.2);
 - That if the motor is stored for a period equal or longer than the oil change interval, the oil must be changed before starting the motor.
- When motors are fitted with sleeve bearings, ensure:
 - Correct oil level for the sleeve bearing. The oil level should be in the center of the sight glass (see Figure 8.3);
 - That the motor is not started or operated with axial or radial loads;
 - That if the motor is stored for a period equal or longer than the oil change interval, the oil must be changed before starting the motor.
- Inspect the capacitor operating condition, if any. If motors are installed for more than two years, but were never commissioned, it is recommended to change the start capacitors since they lose their operating characteristics;
- Ensure that the air inlet and outlet opening are not blocked. The minimum clearance to the nearest wall (L) should be at least $\frac{1}{4}$ of the fan cover diameter (D), see Figure 7.1. The intake air temperature must be at ambient temperature.

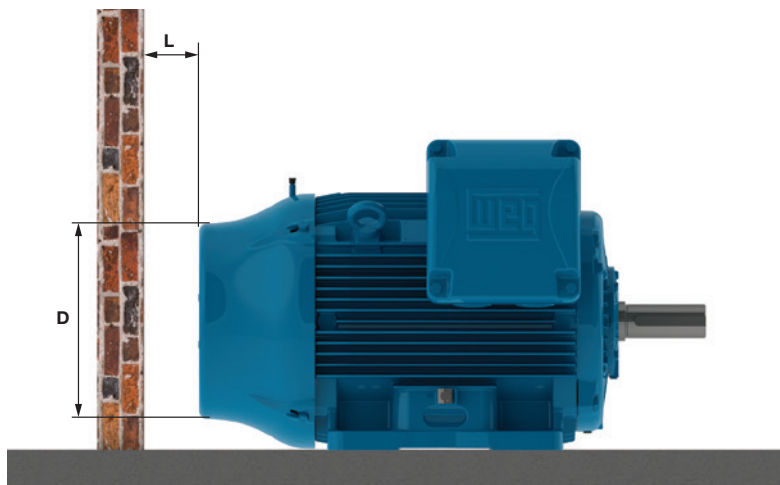

Figure 7.1- Minimum clearance to the wall

Please consider the minimum distances shown in the Table 7.1 as reference value;

Table 7.1 - Minimum distance between the fan cover and wall

Frame size		Distance between the fan cover and the wall (L)	
IEC	NEMA	mm	inches
63	-	25	0.96
71	-	26	1.02
80	-	30	1.18
90	143/5	33	1.30
100	-	36	1.43
112	182/4	41	1.61
132	213/5	50	1.98
160	254/6	65	2.56
180	284/6	68	2.66
200	324/6	78	3.08
225	364/5	85	3.35
250	404/5		
280	444/5	108	4.23
	445/7		
	447/9		
315	L447/9	122	4.80
	504/5		
	5006/7/8		
	5009/10/11		
355	586/7	136	5.35
	588/9		
	5807/8/9		
	5810/11/12		
400	6806/7/8	147	5.79
	6809/10/11		
450	7006/10	159	6.26
500	8006/10	171	6.73
560	8806/10	185	7.28
630	9606/10	200	7.87

- Ensure correct water flow rate and water temperature when water cooled motors are used. See item 7.2;
- Ensure that all rotating parts, such as pulleys, couplings, external fans, shaft, etc. are protected against accidental contact.

Other tests and inspections not included in the manual may be required, depending on the specific installation, application and/or motor characteristics.

After all previous inspections have been carried out, proceed as follows to start the motor:

- Start the motor on no-load (if possible) and check the motor direction of rotation. Check for the presence of any abnormal noise, vibration or other abnormal operating conditions;
- Ensure the motor starts smoothly. If any abnormal operating condition is noticed, switch off the motor, check the assembly system and connections before the motor is started again;
- If excessive vibrations are noticed, check if the motor mounting bolts are well tightened or if the vibrations are not generated and transmitted from adjacent installed equipment. Check the motor vibration periodically and ensure that the vibration limits are as specified in item 7.2.1;
- Start the motor at rated load during a short time and compare the operating current with the rated current indicated on the nameplate;
- Continue to measure the following motor variables until thermal equilibrium is reached: current, voltage, bearing and motor frame temperature, vibration and noise levels;
- Record the measured current and voltage values on the Installation Report for future comparisons.

As induction motors have high inrush currents during start-up, the acceleration of high inertia load requires an extended starting time to reach full speed resulting in fast motor temperature rise. Successive starts within short intervals will result in winding temperature increases and can lead to physical insulation damage reducing the useful life of the insulation system. If the duty cycle S1 / CONT. is specified on the motor nameplate, this means that the motor has been designed for:

- Two successive starts: first start from cold condition, i. e., the motor windings are at room temperature and the second start immediately after the motor stops;
- One start from hot condition, i. e., the motor windings are at rated temperature.

The Troubleshooting Chart in section 10 provides a basic list of unusual cases that may occur during motor operation with the respective corrective actions.

7.2. OPERATING CONDITIONS

Unless otherwise stated in the Purchase Order, electric motors are designed and built to be operated at altitudes up to 1000 meters above sea level and in a temperature range from -20 °C to +40 °C. Any deviation from the normal condition of motor operation must be stated on the motor nameplate. Some components must be changed if the ambient temperature is different from the specified one. Please contact WEG to check the required special features.

For operating temperatures and altitudes differing from those above, the factors indicated in Table 7.2 must be applied to the nominal motor power rating in order to determine the derated available output ($P_{max} = P_{nom} \times$ correction factor).

Table 7.2 - Correction factors for altitude and ambient temperature

T (°C)	Altitude (m)								
	1000	1500	2000	2500	3000	3500	4000	4500	5000
10							0.97	0.92	0.88
15						0.98	0.94	0.90	0.86
20					1.00	0.95	0.91	0.87	0.83
25				1.00	0.96	0.93	0.89	0.85	0.81
30			1.00	0.96	0.92	0.90	0.86	0.82	0.78
35		1.00	0.95	0.93	0.90	0.88	0.84	0.80	0.75
40	1.00	0.97	0.94	0.90	0.86	0.82	0.80	0.76	0.71
45	0.95	0.92	0.90	0.88	0.85	0.81	0.78	0.74	0.69
50	0.92	0.90	0.87	0.85	0.82	0.80	0.77	0.72	0.67
55	0.88	0.85	0.83	0.81	0.78	0.76	0.73	0.70	0.65
60	0.83	0.82	0.80	0.77	0.75	0.73	0.70	0.67	0.62
65	0.79	0.76	0.74	0.72	0.70	0.68	0.66	0.62	0.58
70	0.74	0.71	0.69	0.67	0.66	0.64	0.62	0.58	0.53
75	0.70	0.68	0.66	0.64	0.62	0.60	0.58	0.53	0.49
80	0.65	0.64	0.62	0.60	0.58	0.56	0.55	0.48	0.44

Motors installed inside enclosures (cubicles) must be ensured an air renewal rate in the order of one cubic meter per second for each 100 kW installed power or fraction of installed power. Totally Enclosed Air Over motors - TEAO (fan and exhaust / smoke extraction) are supplied without cooling fan and the manufacturer of the driven machine is responsible for sufficient motor cooling. If no minimum required air speed between motor fins is indicated on the motor nameplate, ensure the air speed indicated in the table 7.3 is provided. The values shown in Table 7.3 are valid for 60 Hz motors. To obtain the minimum air speed for 50 Hz motors, multiply the values in the table by 0.83.

Table 7.3 - Minimum required air speed between motor fins (metres/second)

Frame		Poles			
IEC	NEMA	2	4	6	8
63 to 90	143/5	13	7	5	4
100 to 132	182/4 to 213/5	18	12	8	6
160 to 200	254/6 to 324/6	20	15	10	7
225 to 280	364/5 to 444/5	22	20	15	12
315 to 450	445/7 to 7008/9	25	25	20	15

The voltage and frequency variations may affect the performance characteristics and the electromagnetic compatibility of the motor. The power supply variations should not exceed the values specified in the applicable standards. Examples:

- ABNT NBR 17094 - Parts 1 and 2. The motor has been designed to supply the rated torque for a combined variation in voltage and frequency:
 - Zone A: ±5% of the rated voltage and ±2% of the rated frequency;
 - Zone B: ±10% of the rated voltage and +3% -5% of the rated frequency.

When operated continuously in Zone A or B, the motor may show performance variations and the operating temperature may increase considerably. These performance variations will be higher in Zone B. Thus it is not recommended to operate the motor in Zone B during extended periods.

- IEC 60034-1. The motor has been designed to supply the rated torque for combined variation in voltage and frequency:
 - Zone A: ±5% of the rated voltage and ±2% of the rated frequency;
 - Zone B: ±10% of the rated voltage and +3% -5% of the rated frequency.

When operated continuously in Zone A or B, the motor may show performance variations and the operating temperature may increase considerably. These performance variations will be higher in Zone B. Thus it is not recommended to operate the motor in Zone B during extended periods. For multivoltage motors (example 380-415/660 V), a ±5% voltage variation from the rated voltage is allowed.

- NEMA MG 1 Part 12. The motor has been designed to be operated in one of the following variations:
 - $\pm 10\%$ of the rated voltage, with rated frequency;
 - $\pm 5\%$ of the rated frequency, with rated voltage;
 - A combined variation in voltage and frequency of $\pm 10\%$, provided the frequency variation does not exceed $\pm 5\%$.

If the motor is cooled by ambient air, clean the air inlet and outlet openings and cooling fins at regular intervals to ensure a free airflow over the frame surface. The hot air should never be returned to the motor. The cooling air must be at room temperature limited to the temperature range indicated on the motor nameplate (if no room temperature is specified, please consider a temperature range between $-20\text{ }^{\circ}\text{C}$ and $+40\text{ }^{\circ}\text{C}$).

Table 7.4* shows the minimum required water flow for water cooled motors considering the different frame sizes and the maximum allowed temperature rise of the cooling water after circulating through the motor. The inlet water temperature should not exceed $40\text{ }^{\circ}\text{C}$.

Table 7.4 - Minimum required water flow and the maximum allowed temperature rise of the cooling water after circulating through the motor

Frame size		Flow rate (litres/minute)	Maximum allowed water temperature rise ($^{\circ}\text{C}$)
IEC	NEMA		
180	284/6	12	5
200	324/6	12	5
225	364/5	12	5
250	404/5	12	5
280	444/5	15	6
	445/7		
	447/9		
315	504/5	16	6
355	586/7	25	6
	588/9		

For W60 motors, please see the nameplate at heat-exchanger.

Motors fitted with oil mist lubrication systems can be operated continuously for a maximum of one hour after the failure of the oil pumping system.

Considering the sun's heat increases the operating temperature, externally mounted motors must always be protected from direct sunlight exposure.

Each and every deviation from the normal operating condition (tripping of the thermal protection, noise and vibration level increase, temperature and current rise) should be investigated and corrected by WEG Authorized Service Centers.



Motors fitted with cylindrical roller bearings require a minimum radial load to ensure a normal operation. For information regarding the radial preload, please contact WEG.

7.2.1.Limits of vibration

The vibration severity is the maximum vibration value measured at all positions and in all directions as recommended in the standard IEC 60034-14. Table 7.5 specifies the limits of the maximum vibrations magnitudes according to standard IEC 60034-14 for shaft heights IEC 56 to 400, for vibrations grades A and B. The vibration severity limits in Table 7.5 are given as RMS values (Root Mean Square values or effective values) of the vibration speed in mm/s measured in free suspension condition.

Table 7.5 - Recommended limits for the vibration severity according to standard IEC 60034-14

Shaft height [mm]	$56 \leq H \leq 132$	$132 \leq H \leq 280$	$H > 280$
Vibration grade	Vibration severity on elastic base [mm/s RMS]		
A	1.6	2.2	2.8
B	0.7	1.1	1.8

Notes:

1 - The values in Table 7.5 are valid for measurements carried out with decoupled machines (without load) operated at rated voltage and frequency.

2 - The values in Table 7.5 are valid regardless of the direction of rotation of the machine.

3 - The values in Table 7.5 are not applicable to single-phase motors, three-phase motors powered by a single-phase system or to machines mounted in situ or coupled with inertia flywheels or to loads.

According to NEMA MG 1, the allowed vibration limit for standard motors is 0.15 in/s (peak vibration in in/s).

Note:

For the load operation condition, the use of the standard ISO 10816-3 is recommended for evaluating the motor vibration limits. In the load condition the motor vibration will be influenced by several factors, such as, type of the coupled load, condition of the motor fixation, alignment condition under load, structure or base vibration due to other equipments, etc..

8. MAINTENANCE

The purpose of the maintenance is to extend the useful life of the equipment. The non-compliance with one of these previous items can cause unexpected machine failures.

If motors with cylindrical roller or angular contact bearings are to be transported during the maintenance procedures, the shaft locking device must always be fitted. All HGF, W50 and W60 motors, regardless of the bearing type, must always be transported with the shaft locking device fitted.

All repairs, disassembly and assembly related services must be carried out only by qualified and well-trained personnel by using proper tools and techniques. Make sure that the machine has stopped and it is disconnected from the power supply, including the accessory devices (space heater, brake, etc.), before any servicing is undertaken.

The company does not assume any responsibility or liability for repair services or maintenance operations executed by non-authorized Service Centers or by non qualified service personnel. The company shall have no obligation or liability whatsoever to the buyer for any indirect, special, consequential or incidental loss or damage caused or arising from the company's proven negligence.



Pacemaker users and unqualified personnel shall not open WMagnet and WQuattro motors, because high energy magnets are used.

8.1. GENERAL INSPECTION

The inspection intervals depend on the motor type, application and installation conditions. Proceed as follows during inspection:

- Visually inspect the motor and coupling. Check if abnormal noises, vibrations, excessive heating, wear signs, misalignment or damaged parts are noticed. Replace the damaged parts as required;
- Measure the insulation resistance according to the item 5.4;
- Clean the motor enclosure. Remove oil spills and dust accumulation from the motor frame surface to ensure a better heat transfer to the surrounding ambient;
- Check cooling fan condition and clean the air inlet & outlet openings to ensure a free air flow over the motor;
- Investigate the actual condition of the seals and replace them, if required;
- Drain the condensed water from inside the motor. After draining, reinstall the drain plugs to ensure the degree of protection as indicated on the motor nameplate. The motor must always be positioned so the drain hole is at the lowest position (see item 6);
- Check the connections of the power supply cables, ensuring the correct clearance distance between live and grounded parts, as specified in Table 6.3;
- Check if the tightening torque of the bolted connections and mounting bolts meets the tightening torque specified in Table 8.12;
- Check the status of the cable passages, the cable gland seals and the seals inside the terminal box and replace them, if required;
- Check the bearing operating conditions. Check for the presence of any abnormal noise, vibration or other abnormal operating conditions, like motor temperature rise. Check the oil level, the lube oil condition and compare the workings hours with the informed life time;
- Record and file all changes performed on the motor.



Do not reuse damaged or worn parts. Damaged or worn parts must be replaced by parts supplied by the manufacturer and must be installed as if they were the original parts.

8.2. LUBRICATION

Proper lubrication plays a vital role in the motor performance. Only use the grease or oil types, amounts and lubrication intervals recommended for the bearings. This information is available on the motor nameplate and the lubrication procedures must be carried out according to the type of lubricant (oil or grease).

When the motor is fitted with thermal protection devices for bearing temperature control, consider the operating temperature limits shown in Table 6.5.

The maximum operating temperature of motors used in special applications may differ from those shown in Table 6.4. The grease and oil disposal should be made in compliance with applicable laws in each country.



Please contact WEG when motors are to be installed in special environments or used for special applications.

8.2.1. Grease lubricated rolling bearings



Excess grease causes bearing overheating, resulting in bearing failure.

The lubrication intervals specified in Table 8.1, Table 8.2, Table 8.3, Table 8.4, Table 8.5, Table 8.6, Table 8.7, Table 8.8 and Table 8.9 consider an absolute temperature on the bearing of 70 °C (up to frame size IEC 200 / NEMA 324/6) and 85 °C (for frame size IEC 225 / NEMA 364/5 and above), the motor running at rated speed, a motor mounted in horizontal position and greased with Mobil Polyrex EM grease. Any variation of the parameters listed above must be evaluated.

Table 8.1 - Lubrication intervals for ball bearings

Frame		Poles	Bearing designation	Amount of grease (g)	Lubrication intervals (hours)						
					ODP (Open Drip Proof)		W21 TEFC (Totally Enclosed Fan Cooled)		W22 TEFC (Totally Enclosed Fan Cooled)		
IEC	NEMA				50 Hz	60 Hz	50 Hz	60 Hz	50 Hz	60 Hz	
90	143/5	2	6205	4							
		4									
		6									
		8									
100	-	2	6206	5			20000	20000			
		4									
		6									
		8									
112	182/4	2	6207/ 6307	9			20000				
		4									
		6									
		8									
132	213/5	2	6308	11					25000	25000	
		4									
		6									
		8									
160	254/6	2	6309	13							
		4									
		6									
		8									
180	284/6	2	6311	18	20000	20000					
		4									
		6									
		8									
200	324/6	2	6312	21							
		4									
		6									
		8									
225 250 280 315 355	364/5 404/5 444/5	2	6314	27							
		4									
		6									
		8									
	445/7 447/9 L447/9	504/5 5008	2	6316	34						
			4								
			6								
			8								
	5010/11 586/7 588/9		2	6319	45						
			4								
			6								
			8								
		4	6322	60							
		6									
		8									
		8									

Table 8.2 - Lubrication intervals for cylindrical roller bearings

Frame		Poles	Bearing designation	Amount of grease (g)	Lubrication intervals (hours)						
					ODP (Open Drip Proof)		W21 TEFC (Totally Enclosed Fan Cooled)		W22 TEFC (Totally Enclosed Fan Cooled)		
IEC	NEMA				50 Hz	60 Hz	50 Hz	60 Hz	50 Hz	60 Hz	
160	254/6	2	NU309	13	20000	19600		13300	9800	16000	12000
		4				20000		20000	20000	25000	25000
		6				20000		20000	20000	25000	25000
		8				20000		20000	20000	25000	25000
180	284/6	2	NU311	18	18400	12800	9200	6400	11000	8000	
		4			20000		20000	20000	19100	25000	25000
		6			20000		20000	20000	20000	25000	25000
		8			20000		20000	20000	20000	25000	25000
200	324/6	2	NU312	21	15200	10200	7600	5100	9000	6000	
		4			20000		20000	20000	17200	21000	
		6			20000		20000	20000	20000	25000	
		8			20000		20000	20000	20000	25000	
225 250 280 315 355	364/5 404/5 444/5 445/7 447/9	4	NU314	27	17800	14200	8900	7100	11000	9000	
		6			20000		20000	13100	11000	16000	13000
		8			20000		20000	16900	15100	20000	19000
		4			15200		12000	7600	6000	9000	7000
	504/5 5008 5010/11 586/7 588/9	NU316	34	20000	19000	11600	9500	14000	12000		
				6	20000		15500	13800	19000	17000	
				8	20000		20000	20000	20000	25000	
				4	12000		9400	6000	4700	7000	5000
	NU319	45	19600	15200	9800	7600	12000	9000			
			6	20000		20000	13700	12200	17000	15000	
			8	20000		20000	20000	20000	25000	25000	
			4	8800		6600	4400	3300	5000	4000	
NU322	60	15600	11800	7800	5900	9000	7000				
		6	20000		20000	11500	10700	14000	13000		
		8	20000		20000	20000	20000	25000	25000		
		4	20000		20000	20000	20000	25000	25000		

Table 8.3 - Lubrication intervals for ball bearings - HGF line

Frame		Poles	Bearing designation	Amount of grease (g)	Lubrication intervals (hours)	
IEC	NEMA				50 Hz	60 Hz
315L/A/B and 315C/D/E	5006/7/8T and 5009/10/11T	2	6314	27	3100	2100
		4 - 8	6320 6316	50 34	4500	4500
355L/A/B and 355C/D/E	5807/8/9T and 5810/11/12T	2	6314	27	3100	2100
		4 - 8	6322 6319	60 45	4500	4500
400L/A/B and 400 C/D/E	6806/7/8T and 6809/10/11T	2	6315	30	2700	1800
		4 - 8	6324 6319	72 45	4500	4500
450	7006/10	2	6220	31	2500	1400
		4	6328	93	4500	3300
			6322	60		
		6 - 8	6328	93	4500	4500
6322	60					
500	8006/10	4	6330	104	4200	2800
			6324	72	4500	4500
		6 - 8	6330 6324	104 72		
560	8806/10	4 - 8	*Upon request			
630	9606/10	4 - 8				

Table 8.4 - Lubrication intervals for cylindrical roller bearings - HGF line

Frame		Poles	Bearing designation	Amount of grease (g)	Lubrication intervals (hours)	
IEC	NEMA				50 Hz	60 Hz
315L/A/B and 315C/D/E	5006/7/8 and 5009/10/11	4	NU320	50	4300	2900
		6 - 8			4500	4500
355L/A/B and 355C/D/E	5807/8/9 and 5810/11/12	4	NU322	60	3500	2200
		6 - 8			4500	4500
400L/A/B and 400C/D/E	6806/7/8 and 6809/10/11	4	NU324	72	2900	1800
		6 - 8			4500	4500
450	7006/10	4	NU328	93	2000	1400
		6			4500	3200
		8			4500	4500
500	8006/10	4	NU330	104	1700	1000
		6			4100	2900
		8			4500	4500
560	8806/10	4	NU228 + 6228	75	2600	1600
		6 - 8		106	4500	4500
630	9606/10	4	NU232 + 6232	92	1800	1000
		6		120	4300	3100
		8		140	4500	4500

Table 8.5 - Lubrication intervals for ball bearings - W50 line

	Frame		Poles	DE Bearing	Amount of grease (g)	50 Hz (h)	60 Hz (h)	NDE Bearing	Amount of grease (g)	50 Hz (h)	60 Hz (h)
	IEC	NEMA									
Horizontal mounting Ball bearings	315 H/G	5009/10	2	6314	27	4500	3500	6314	27	4500	3500
			4 - 8	6320	50		4500	6316	34		4500
	355 J/H	5809/10	2	6314	27	4500	3500	6314	27	4500	3500
			4 - 8	6322	60		4500	6319	45		4500
	400 L/K and 400 J/H	6806/07 and 6808/09	2	6218	24	3800	2500	6218	24	3800	1800
			4 - 8	6324	72	4500	4500	6319	45	4500	4500
	450 L/K and 450 J/H	7006/07 and 7008/09	2	6220	31	3000	2000	6220	31	3000	2000
			4	6328	93	4500	3300	6322	60	4500	4500
			6 - 8				4500				
	Vertical mounting Ball bearings	315 H/G	5009/10	2	7314	27	2500	1700	6314	27	2500
4				6320	50	4200	3200	6316	34	4500	4500
6 - 8						4500	4500				
355 J/H		5809/10	2	7314	27	2500	1700	6314	27	2500	1700
			4	6322	60	3600	2700	6319	45	4500	3600
			6 - 8			4500	4500				4500
400 L/K and 400 J/H		6806/07 and 6808/09	2	7218	24	2000	1300	6218	24	2000	1300
			4	7324	72	3200	2300	6319	45	4500	3600
			6			4500	4300				4500
			8			4500	4500				4500
450 L/K and 450 J/H		7006/07 and 7008/09	2	7220	31	1500	1000	6220	31	1500	1000
			4	7328	93	2400	1700	6322	60	3500	2700
			6			4100	3500			4500	4500
			8			4500	4500			4500	4500

Table 8.6 - Lubrication intervals for cylindrical roller bearings - W50 line

	Frame		Poles	DE Bearing	Amount of grease (g)	50 Hz (h)	60 Hz (h)	NDE Bearing	Amount of grease (g)	50 Hz (h)	60 Hz (h)
	IEC	NEMA									
Horizontal mounting Roller bearings	315 H/G	5009/10	4	NU320	50	4300	2900	6316	34	4500	4500
			6 - 8			4500	4500				
	355 J/H	5809/10	4	NU322	60	3500	2200	6319	45	4500	4500
			6 - 8			4500	4500				
	400 L/K and 400 J/H	6806/07 and 6808/09	4	NU324	72	2900	1800	6319	45	4500	4500
			6 - 8			4500	4500				
	450 L/K and 450 J/H	7006/07 and 7008/09	4	NU328	93	2000	1400	6322	60	4500	4500
			6			3200					
			8			4500					

Table 8.7 - Lubrication intervals for ball bearings - W40 line

	Frame		Poles	DE Bearing	Amount of grease (g)	50 Hz (h)	60 Hz (h)	NDE Bearing	Amount of grease (g)	50 Hz (h)	60 Hz (h)
	IEC	NEMA									
Horizontal mounting Ball bearings	160M/L	254/6	2 - 8	6309	13	20000	20000	6209	9	20000	20000
				6311	18			6211	11		
				6312	21						
	225S/M	364/5	2	6314	27	18000	14400	6212	13	20000	20000
			4 - 8								
	250S/M	404/5	2	6316	34	20000	20000	6212	13	20000	20000
			4 - 8								
	280S/M	444/5	2	6314	27	18000	14400	6314	27	18000	14400
			4 - 8	6319	45	20000	20000				
	280L	447/9	2	6314	27	18000	14400	6314	27	18000	14400
			4 - 8	6319	45	20000	20000			20000	20000
	315G/F	5010/11	2	6314	27	4500	4500	6314	27	4500	4500
			4 - 8	6319	45	4500	4500				
	355J/H	L5010/11	2	6218	24	2200	2200	6218	24	2200	2200
			4 - 8	6224	43	4500	4500			4500	4500
	400J/H	L5810/11	2	6220	31	2200	2200	6220	31	2200	2200
			4 - 8	6228	52	4500	4500			4500	4500
	450K/J	L6808/09	2	6220	31	2200	2200	6220	31	2200	2200
4 - 8			6228	52	4500	4500	4500			4500	

Table 8.8 - Lubrication intervals for cylindrical roller bearings - W40 line

	Frame		Poles	DE Bearing	Amount of grease (g)	50 Hz (h)	60 Hz (h)	NDE Bearing	Amount of grease (g)	50 Hz (h)	60 Hz (h)	
	IEC	NEMA										
Horizontal mounting Roller bearings	225S/M	364/5	4 – 8	NU314	27	20000	20000	6314	27	20000	20000	
	250S/M	404/5		NU316	34							
	280S/M	444/5		NU319	45		18800					
	280L	447/9										
	315G/F	5010/11		4500	NU224	43	4500	6218	24	4500	4500	
	355J/H	L5010/11										
	400J/H	L5810/11					3300	6220				31
	450K/J	L6808/09										

Table 8.9 - Lubrication intervals for ball bearings and for cylindrical roller bearings - line W60

	Frame		Poles	DE Bearing	Amount of grease (g)	50 Hz (h)	60 Hz (h)	NDE Bearing	Amount of grease (g)	50 Hz (h)	60 Hz (h)	
	IEC	NEMA										
Horizontal mounting Ball bearings	355H/G	5810/11	2	6218	24	2300	1500	6218	24	2300	1500	
			4/8	6224	43	4500	4500			4500	4500	
	400J/H	L5810/11	2	6220	31	1800	1200	6220	31	1800	1200	
			4/8	6228	52	4500	4500			4500	4500	
	400G/F	6810/11	2	6220	31	1800	1200			1800	1200	
			4/8	6228	52	4500						
Horizontal mounting Roller bearings	355H/G	5810/11	4	NU224	43	4500	4500	6218	24	4500	4500	
			6/8									
	400J/H	L5810/11	4	NU228	52		1500	4500	6220		31	1500
			6/8									
	400G/F	6810/11	4			1500	4500	1500		4500		
			6/8									

For each increment of 15 °C above the bearing temperature, the relubrication intervals given in the Table must be halved. The relubrication interval of motors designed by the manufacturer for mounting in horizontal position, but installed in vertical position (with WEG authorization), must be halved.

For special applications, such as: high and low temperatures, aggressive environments, driven by frequency inverter (VFD - frequency inverter), etc., please contact WEG about the required amount of grease and the relubrication intervals.

8.2.1.1. Motor without grease fitting

Motors without grease fittings must be lubricated in accordance with the existing Maintenance Plan. Motor disassembly must be carried out as specified in Item 8.3. If motors are fitted with shielded bearings (for example, ZZ, DDU, 2RS, VV), these bearings must be replaced at the end of the grease service life.

8.2.1.2. Motor with grease fitting

To lubricate the bearings with the motor stopped, proceed as follows:

- Before lubricating, clean the grease nipple and immediate vicinity thoroughly;
- Lift grease inlet protection;
- Remove the grease outlet plug (not required for motors with automatic grease relief fittings, such as IEEE Std 841);
- Pump in approximately half of the total grease indicated on the motor nameplate and run the motor for about 1 (one) minute at rated speed;
- Switch-off the motor and pump in the remaining grease;
- Lower again the grease inlet protection and reinstall the grease outlet plug.

To grease the motor while running, proceed as follows:

- Before lubricating, clean the grease nipple and immediate vicinity thoroughly;
- Lift grease inlet protection;
- If safe and possible, remove the grease outlet plug;
- Pump the total grease indicated on the motor nameplate;
- Lower again the grease inlet protection and reinstall the grease outlet plug (if removed).



For lubrication, use only manual grease gun.



Due to internal clearances in the motor, it is possible that, in the first re-lubrication of the bearings, the grease will not come out of the grease outlet. Therefore, do not apply excess grease expecting for it to come out.



If Motors are provided with a spring device for grease removal, the grease excess must be removed by pulling the rod and cleaning the spring until the spring does not remove more grease.

8.2.1.3. Compatibility of the Mobil Polyrex EM grease with other greases

The Mobil Polyrex EM grease has a polyurea thickener and a mineral oil and it is not compatible with other greases.

If you need another type of grease, contact WEG.

It is not recommended to mix different types of greases. In such a case, clean the bearings and lubrication channels before applying new grease.

The used grease must have in its formulation corrosion and oxidation inhibitors.

8.2.2. Oil lubricated bearings

To change the oil of oil lubricated motor proceed as follows:

- Switch-off the motor;
- Remove threaded oil drain plug;
- Open the valve and drain the oil;
- Close the drain valve again;
- Reinstall the threaded oil drain plug;
- Fill-up with the type and amount of oil as specified on the nameplate;
- Check oil level. The oil level is OK when the lubricant can be viewed approximately in the center of the sight glass;
- Reinstall oil inlet plug;
- Check for oil leaks and ensure that all not used threaded plugs are closed with plugs.

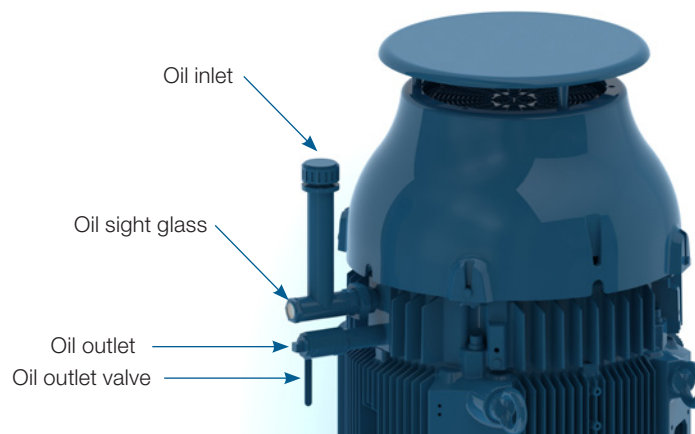

Figure 8.1 - Oil lubricated bearing - vertical mounting

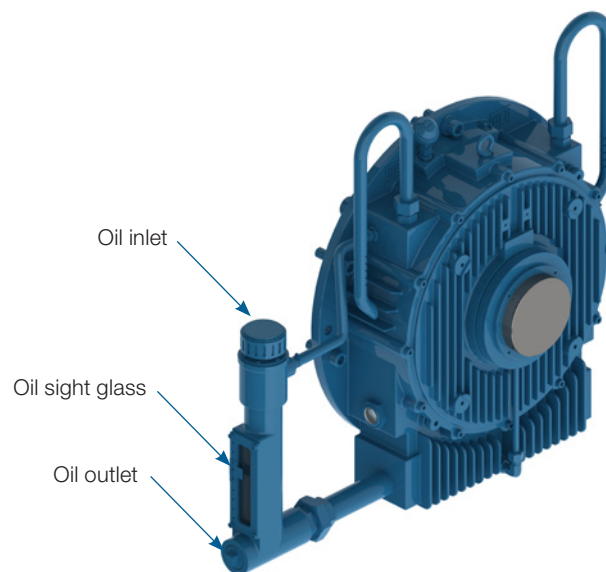

Figure 8.2 - Oil lubricated bearing - horizontal mounting

The bearing lubricating oil must be replaced as specified on the nameplate or whenever changes in the oil properties are noticed. The oil viscosity and pH must be checked periodically. The oil level must be checked every day and must be kept in the center of the sight glass.

Please contact WEG, when oils with different viscosities should be used.

Note:

The HGF vertical mounted motors with high axial thrust are supplied with grease lubricated DE-bearings and with oil lubricated NDE-bearings. The DE-bearings must be lubricated according to recommendations in item 8.2.1. Table 8.10 specifies the oil type and the amount of oil required for this motor lubrication.

Table 8.10 - Oil properties for HGF vertical mounted motors with high axial thrust

Mounting - high axial thrust	Frame		Poles	Bearing designation	Oil (liters)	Interval (h)	Lubricant	Lubricant specification
	IEC	NEMA						
	315L/A/B and 315C/D/E	5006/7/8T and 5009/10/11T	4 - 8	29320	20	8000	FUCHS Renolin DTA 40 / Mobil SHC 629	ISO VG150 mineral oil with antifoam and antioxidant additives
	355L/A/B and 355C/D/E	5807/8/9T and 5810/11/12T			26			
	400L/A/B and 400C/D/E	6806/7/8T and 6809/10/11T			37			
	450	7006/10			45			

8.2.3. Oil mist lubricated bearings

Check the service conditions of the seals and if replacement is required use only original components. Clean the seal components before assembly (bearing caps, end shields, etc.).

Apply joint sealant between the bearing caps and end shields. The joint sealant must be compatible with the used lubricating oil. Connect the oil lubricant tubes (oil inlet and oil outlet tubes and motor drain tube), as shown in Figure 6.12.

8.2.4. Sleeve bearings

The lubricating oil of sleeve bearings must be changed at the intervals specified in Table 8.11. To replace the oil, proceed as follows:

- NDE-bearing: remove the protection plate from the fan cover;
- Drain the oil through the drain hole located at the bottom of the bearing (see Figure 8.3);
- Close the oil drain hole;
- Remove the oil inlet plug;
- Fill the sleeve bearing with the specified oil and with the amount of oil specified in the Table 8.11;
- Check the oil level and ensure it is kept close to the center of the sight glass;
- Install the oil inlet plug;
- Check for oil leaks.

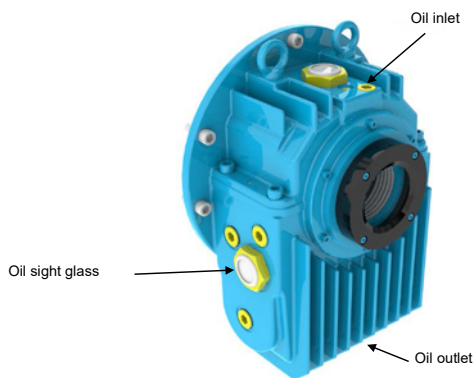

Figure 8.3 - Sleeve bearing

Table 8.11 - Oil properties for sleeve bearings

Frame		Poles	Bearing designation	Oil (liters)	Interval (h)	Lubricant	Lubricant specification
IEC	NEMA						
315	5000	2	9-80	3.6	8000	FUCHS Renolin DTA 10	ISO VG32 mineral oil with antifoam and antioxidant additives
355	5800						
400	6800						
450	7000						
315	5000	4 - 8	9-90	4.7	8000	FUCHS Renolin DTA 15	ISO VG46 mineral oil with antifoam and antioxidant additives
355	5800		9-100				
400	6800		11-110				
450	7000		11-125				
500	8000						

The lubricating oil must be replaced as specified on the nameplate or whenever changes on the oil properties are noticed. The oil viscosity and pH must be checked periodically. The oil level must be checked every day and kept in the center of the sight glass.
Please contact WEG, when oils with different viscosities are to be used.

8.3. MOTOR ASSEMBLY AND DISASSEMBLY



All repair services on motors should be always performed by qualified personnel and in accordance with the applicable laws and regulations in each country. Always use proper tools and devices for motor disassembly and assembly.



Disassembly and assembly services can be carried out only after the motor has been disconnected from the power supply and is completely stopped.

Dangerous voltages may be present at the motor terminals inside the terminal box since capacitors can retain electrical charge for long periods of time even when they are not connected directly to a power source or when space heaters are connected to the motor or when the motor windings are used as space heaters. Dangerous voltages may be present at the motor terminals when they are driven by frequency inverter even when they are completely stopped.

Record the installation conditions such as terminal connection diagram, alignment / leveling conditions before starting the disassembly procedures. These records should be considered for later assembly.

Disassemble the motor carefully without causing scratches on machined surfaces or damaging the threads.

Assemble the motor on a flat surface ensuring a good support base. Footless motors must be fixed/locked on the base to prevent accidents.

Handle the motor carefully to not damage the insulated components such as windings, insulated rolling bearings, power cables etc..

Seal elements, such as joint seals and bearing seals should always be replaced when wear or damage is noticed.

Motors with degree of protection higher than IP55 are supplied with joint and screw seal Loctite 5923 (Henkel) Clean the components and apply a new coat of Loctite 5923 on the surfaces before assembly.



For motors with permanent magnet rotor (lines W22 Quattro and W22 Magnet), the motor assembly and disassembly require the use of proper devices due to the attracting or repelling forces that occur between metallic parts. This work must only be performed by a WEG Authorized service center specifically trained for such an operation. People with pacemakers cannot handle these motors. The permanent magnets can also cause disturbances or damages to other electric equipment and components during maintenance.



For the W40, W50 and HGF motor lines provided with axial fans, the motor and the axial fan have different markings for indicating the direction of rotation for prevent incorrect assembly. The axial fan must be assembled so that the indicative arrow for direction of rotation is always visible, viewing the non-drive end side. The marking indicated on the axial fan blade, CW for clockwise direction of rotation or CCW for counterclockwise direction of rotation, indicates the direction of rotation of the motor viewing the drive end side.

8.3.1. Terminal box

Proceed as follows to remove the terminal box cover and to disconnect/connect the power supply cables and the cables of the accessory devices:

- Ensure that during the screw removal the terminal box cover does not damage the components installed inside the terminal box;
- If the terminal box cover is fitted with lifting eyebolt, lift the terminal box cover always by its lift eyebolt;
- If motors are supplied with terminal blocks, ensure the correct tightening torque on the motor terminals as specified in Table 8.12;



For flying leads motors, do not push the overlength of leads into the motor in order to prevent that they touch the rotor.

- Ensure that the cables do not contact sharp edges;
- Ensure that the original IP degree of protection is not changed and is maintained as indicate on the motor nameplate. The power supply cables and the control cables must always be fitted with components (cable glands, conduits) that meet the applicable standards and regulations of each country;
- Ensure that the pressure relief device is in perfect operating condition, if provided. The seals in the terminal box must be in perfect condition for reuse and must be reinstalled correctly to ensure the specified degree of protection;
- Ensure the correct tightening torque for the securing bolts of the terminal box cover as specified in Table 8.12.

Table 8.12 - Tightening torque for the securing bolts [Nm]

Screw type and seal	M4	M5	M6	M8	M10	M12	M14	M16	M20
Hex bolt/hex socket bolt (rigid joint)	-	3,5 to 5	6 to 9	14 to 20	28 to 40	45 to 70	75 to 110	115 to 170	230 to 330
Combined slotted screw (rigid joint)	1,5 to 3	3 to 5	5 to 10	10 to 18	-	-	-	-	-
Hex bolt/hex socket bolt (flexible joint)	-	3 to 5	4 to 8	8 to 15	18 to 30	25 to 40	30 to 45	35 to 50	-
Combined slotted screw (flexible joint)	-	3 to 5	4 to 8	8 to 15	-	-	-	-	-
Terminal blocks	1 to 1,5	2 to 4 1)	4 to 6,5	6,5 to 9	10 to 18	15,5 to 30	-	30 to 50	50 to 75
Grounding terminals	1,5 to 3	3 to 5	5 to 10	10 to 18	28 to 40	45 to 70	-	115 to 170	-

Note: 1) For 12-pin terminal block, apply the minimum torque of 1.5 Nm and maximum torque of 2.5 Nm.

8.4. DRYING THE STATOR WINDING INSULATION

Dismantle the motor completely. Remove the end shields, the rotor with the shaft, the fan cover, the fan and the terminal box before the wound stator with the frame is transferred to the oven for the drying process. Place the wound stator in the oven heated to max. 120 °C for two hours. For larger motors a longer drying time may be required. After the drying process has been concluded, allow the stator to cool to room temperature. Measure the insulation resistance again as described in item 5.4. Repeat the stator drying process if the required insulation resistance does not meet the values specified in Table 5.3. If the insulation resistance does not improve despite several drying processes, evaluate the causes of the insulation resistance drop carefully and an eventual replacement of the motor winding may be required. If in doubt contact WEG.



To prevent electrical shock, discharge the motor terminals immediately before, and after each measurement. If the motor is equipped with capacitors, these must be discharged before beginning any repair.



Pacemaker users and unqualified personnel shall not open WMagnet and WQuattro motors, because high energy magnets are used.

8.5. SPARE PARTS

When ordering spare parts, always provide complete motor designation, indicating the motor type, the code number and the serial number, which are stated on the motor nameplate.

Spare parts must always be purchased from WEG authorized Service Centers. The use of non-original spare parts can cause motor failure, performance drop and void the product warranty.

The spare parts must be stored in a clean, dry and properly ventilated room, with relative air humidity not exceeding 60%, with ambient temperature between 5 °C and 40 °C, free of dust, vibrations, gases, corrosive smokes and at constant temperature. The spare parts must be stored in their normal mounting position without placing other components onto them.

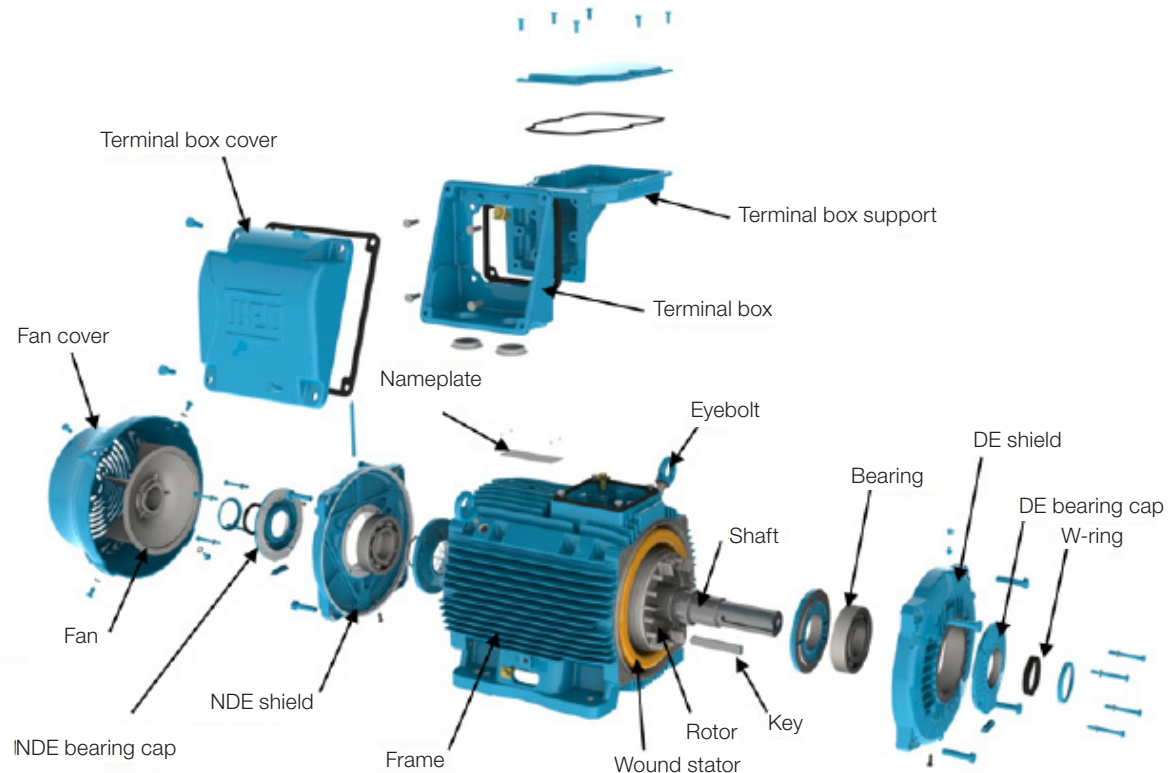

Figure 8.4 - Exploded view of the components of a W22 motor



9. ENVIRONMENTAL INFORMATION

9.1. PACKAGING

WEG electric motors are supplied in cardboard, plastic or wooden packaging. These materials can be recycled and must be disposed according to the applicable laws and regulations in each country. All wood used in the packaging of WEG motors come from the company reforestation program and is not submitted to any chemical conservation treatment.

9.2. PRODUCT

Electric motors consist mainly of ferrous metals (steel plates and cast iron), non ferrous metals (copper and aluminum) and plastic materials.

In general, electric motors have relatively long service live. However when they must be discarded, WEG recommends to dismantle the motor, sort the different materials and send them for recycling.

No-recyclable materials should be disposed of at industrial landfills according to the applicable environmental laws and regulations in each country, or co-processed in cement kilns or incinerated.

The recycling service providers, the disposal in industrial landfills, the waste co-processing or the incineration process must be properly authorized by the state environment agency to carry out these activities.

10. TROUBLESHOOTING CHART X SOLUTIONS

This troubleshooting chart provides a basic list of problems that may occur during motor operation, possible causes and recommended corrective actions. In case of doubts, please contact WEG Service Center.

Problem	Possible cause	Corrective action
Motor does not start, neither coupled nor decoupled	Power cables are interrupted	Check the control panel and the motor power supply cables
	Blown fuses	Replace blown fuses
	Wrong motor connection	Correct the motor connection according to connection diagram
	Locked rotor	Check motor shaft to ensure that it rotates freely
The motor starts at no-load, but fails when load is applied. It starts very slowly and does not reach the rated speed	Load torque is too high during start-up	Do not start the motor on load
	Too high voltage drop in the power cables	Check the installation dimensioning (transformer, cable cross section, relays, circuit breakers, etc.)
Abnormal/excessive noise	Defective transmission component or defective driven machine	Check the transmission force, the coupling and the alignment
	Misaligned / unlevelled base	Align / level the motor with the driven machine
	Unbalanced components or unbalanced driven machine	Balance the machine set again
	Different balancing methods used for motor and coupling balancing (halve key, full key)	Balance the motor again
	Wrong motor direction of rotation	Reverse the direction of rotation
	Loose bolts	Retighten the bolts
	Foundation resonance	Check the foundation design
	Damaged bearings	Replace the bearings
Motor overheating	Insufficient cooling	Clean air inlet and outlet and cooling fins
		Check the minimum required distance between the fan cover and nearest walls. See item 7
		Check air temperature at inlet
	Overload	Measure motor current, evaluate motor application and if required, reduce the load
	Number of starts per hour is too high or the load inertia moment is too high	Reduce the number of starts per hour
	Power supply voltage too high	Check the motor power supply voltage. Power supply voltage must not exceed the tolerance specified in item 7.2
	Power supply voltage too low	Check the motor power supply voltage and the voltage drop. Power supply voltage must not exceed the tolerance specified in item 7.2
	Interrupted power supply	Check the connection of the power cables
	Voltage unbalance at the motor terminals	Check for blown fuses, wrong commands, voltage unbalance in the power line, phase fault or interrupted power cables
	Direction of rotation is not compatible with the unidirectional fan	Check if the direction of rotation matches the rotation arrow indicated on end shield
Bearing overheating	Excessive grease/oil	Clean the bearing and lubricate it according to the provided recommendations
	Grease/oil aging	
	The used grease/oil does not matches the specified one	
	Lack of grease/oil	Lubricate the bearing according to the provided recommendations
	Excessive axial or radial forces due to the belt tension	Reduce the belt tension
Reduce the load applied to the motor		