



www.weg.net  
10001152788.01

INSTRUÇÃO DE MONTAGEM - JC CWM9...105  
ASSEMBLY INSTRUCTION - JC CWM9...105  
INSTRUCTIVO DE MONTAJE - JC CWM9...105  
MONTAGEANLEITUNG - JC CWM9...105

**GARANTIA:** A WEG oferece garantia contra defeitos de fabricação ou de materiais para produtos seriados, quando aplicados sob condições normais e de acordo com os limites de suas capacidades, por um período de 2 anos (incluindo a garantia legal de 90 dias) a partir da data do fornecimento.

**WARRANTY:** WEG offers warranty of two years against defects in materials or manufacturing for standard products, when they are applied under normal conditions and in accordance with the limit of their capacities.

**GARANTIA:** WEG ofrece garantía contra defectos de fabricación o de materiales para productos seriados, cuando aplicados bajo condiciones normales y de acuerdo a los límites de sus capacidades, por un periodo de 2 años a contar de la fecha de suministro.

**GARANTIE:** WEG bietet eine zweijährige Garantie bei Material-oder Produktionsfehlern auf Standard Produkte, wenn diese unter normalen Betriebsbedingungen und bestimmungsgemäß eingesetzt werden.

**PRAZO DE VALIADE:** Produto não perecível.

**VALIDITY:** No perishable products.

**PLAZO DE VALIDAD:** Producto no perecible.

**HALTBARKEIT:** Unbegrenzte Haltbarkeit.

**ATENÇÃO:**

- Desconecte da rede elétrica antes de proceder qualquer trabalho neste equipamento.

- Somente profissionais qualificados podem efetuar a instalação e manutenção.

- Obter normas nacionais, estaduais, locais e instruções de operação.

**WARNING:**

- Disconnect power before proceeding with any work on this equipment.

- Installation and maintenance by technical personnel only.

- Attend the national, regional and local standards and follow the operating instruction.

**ATENCIÓN:**

- Desconectar de la red eléctrica antes de hacer cualquier trabajo en este equipamiento.

- Recomendase instalación por profesional calificado.

- Respetar normas nacionales y locales.

- Producto destinado a utilización en instalaciones eléctricas de baja tensión.

**WARNING:**

- Vor Arbeiten jeglicher Art am Gerät muss Spannungsfreiheit hergestellt werden. Installation und Service kann nur von einer Elektrofachkraft vorgenommen werden.

- Die Errichtungs- und Betriebsmittelbestimmungen,

Unfallverhütungsvorschriften sowie die Bedienungsanleitung sind zu berücksichtigen.

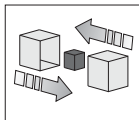

CWM50...105

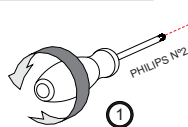

1

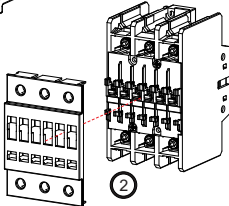
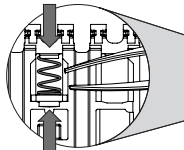
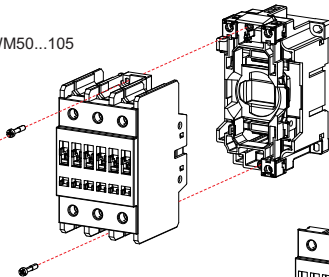

2

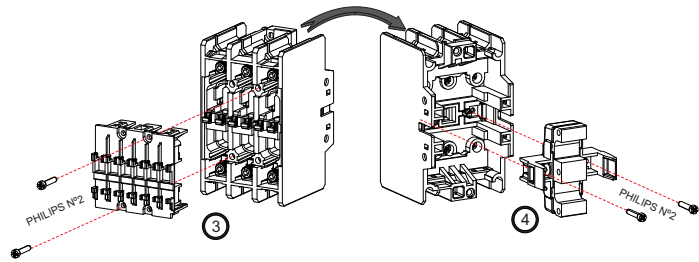

3

4

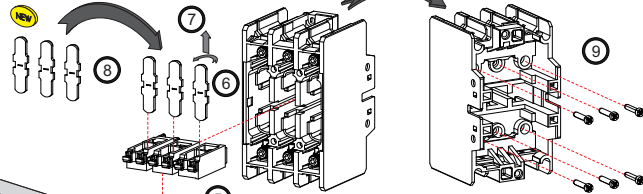

8

6

7

5

9

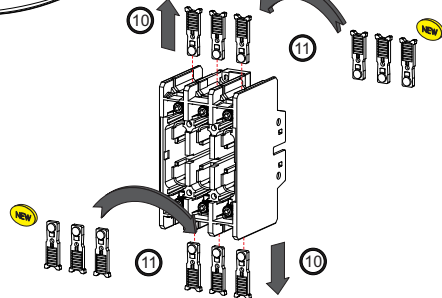

10

11

11

10

CWM9...25

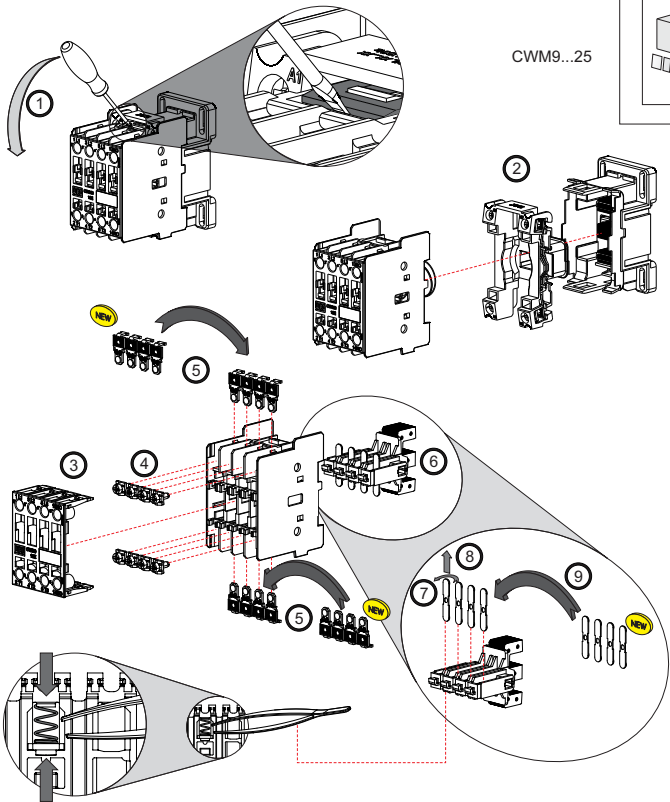
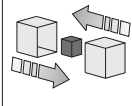

CWM32...40

