

DATASHEET

Variable Speed Drives



Main Features

Reference : NACFW110435T6OYZ
 Product code : 11994602
 Product line : CFW11

Basic data

Power supply : 500-690V
 Input minimum-maximum voltage : 425-759 V
 Number of phases : 3
 Input : 3
 Output : 3

Supply voltage range	500-690V		500-690V	
	Normal (ND)	Heavy (HD)	Normal (ND)	Heavy (HD)
Overload regime				
Rated current	435A	357	365A	312A
Overload current at 60 s	479A	536A	402A	468A
Overload current at 3 s	653A	714.0	548A	624A

Maximum applicable motor

Voltage/Frequency	Power (HP / kW) [1]	
	Normal Overload (ND)	Heavy Overload (HD)
525V / 50Hz	430 / 315	340 / 250
575V / 60Hz	450 / 330	350 / 260
690V / 50Hz	480 / 355	480 / 355
690V / 60Hz	550 / 400	430 / 315

Dynamic braking [2] : Standard without braking
 Electronic supply : Internal
 Safety Stop : Yes
 RFI internal filter [3] : With filter (C3 category)
 External filter : Not available
 Link Inductor : Yes
 Memory card : Included in the product
 USB port : Standard in the product
 Line frequency : 50/60Hz
 Line frequency range (minimum - maximum) : 48-62 Hz
 Phase unbalance : Less or equal to 3% of input rated line voltage
 Transient voltage and overvoltage : Category III
 Rated current of single-phase input :
 - Overload (ND) :
 - Overload (HD) :
 Rated current of three-phase input :
 - Overload (ND) : 435A
 - Overload (HD) : 357A
 Power factor : 0,94
 Displacement factor : 0,98
 Rated efficiency : ≥ 98%
 Maximum connections (power up cycles - on/off) per hour : 60
 DC power supply : Not allow
 Standard switching frequency :
 - Overload ND : 2 kHz
 - Overload HD : 2 kHz
 Selectable switching frequency : 1,25 and 2 kHz
 Real-time clock : Yes, in the HMI
 COPY Function : Yes, by HMI/MMF
 Dissipated power:

Mounting type	Overload		Overload (*)	
	ND	HD	ND	HD
Surface	6828 W	5640 W	6874 W	5905 W
Flange	2520 W	2104 W	2536 W	2197 W

Source available to the user

Output voltage : 24 Vcc
 Maximum capacity : 500 mA

Control/performance data

Power supply : Switched-mode power supply
 Control method : V/f, VVW, Vector and PM motor
 Encoder interface : Only with 'Slot 2' accessory

Control/performance data

Control output frequency	: 0 to 300 Hz
Frequency resolution	: Equivalent to 1 rpm
V/F Control	
- Speed resolution	: 1% of rated speed
- Speed range	: 1:20
VVW Control	
- Speed resolution	: 1% of rated speed
- Speed range	: 1:30
Sensorless vector control	
- Speed resolution	: 0,5% of rated speed
- Speed range	: 1:100
Vector control with encoder	
- Speed resolution	: 0,05% of rated speed
- Speed range	: Up to 0 rpm

Analog inputs

Quantity (standard)	: 2
Levels	: 0-10V, 0/4-20mA and -10-+10V
Impedance	
- Impedance for voltage input	: 400 kΩ
- Impedance for current input	: 500 Ω
Function	: Programmable
Maximum allowed voltage	: ±30 Vcc

Digital inputs

Digital inputs - Quantity (standard)	: 6
Activation	: Active low and high
Maximum low level	: 3 V
Minimum high level	: 18 V
Input current	: 11 mA
Maximum input current	: 13,5 mA
Function	: Programmable
Maximum allowed voltage	: 30 Vcc

Analog outputs

Analogic outputs - Quantity (standard)	: 2
Levels	: 0 to 10V, 0 to 20mA and 4 to 20mA
RL for voltage output	: 10 kΩ
RL for current output	: 500 Ω
Function	: Programmable

Digital outputs

Digital outputs - Quantity (standard)	: 3 NO/NC relays
Maximum voltage	: 240 Vca
Maximum current	: 1 A
Function	: Programmable

Communication

- Modbus-RTU (with accessory: RS485-01; RS485-05; CAN/RS485-01; RS232-01 or RS232-05)
- Modbus/TCP (with accessory: MODBUSTCP-05)
- Profibus DP (with accessory: PROFDP-05)
- Profibus DPV1 (with accessory: PROFIBUS DP-01)
- Profinet (with accessory: PROFINETIO-05)
- CANopen (with accessory: CAN/RS485-01 or CAN-01)
- DeviceNet (with accessory: DEVICENET-05; CAN/RS485-01 or CAN-01)
- EtherNet/IP (with accessory: ETHERNET/IP-05 or ETHERNETIP-2P-05)
- EtherCAT (with accessory: ETHERCAT-01)
- BACnet (with accessory: RS485-01 or CAN/RS485-01)

Protections available

- Output overcurrent/short circuit
- Power supply phase loss
- Under/Overvoltage in power
- Overtemperature
- Motor overload
- IGBT's modules overload
- Fault/External alarm
- Breaking resistor overload
- CPU or memory failure
- Output phase-ground short circuit

Operation interface (HMI)

Availability	: Included in the product
Installation	: Local
Number of HMI buttons	: 9
Display	: Graphic LCD
Indication accuracy	: 5% of rated current
Speed resolution	: 1 rpm

DATASHEET

Variable Speed Drives



Operation interface (HMI)

Standard HMI degree of protection	: IP56
HMI battery type	: CR2032
HMI battery life expectancy	: 10 years
Remote HMI type	: Detachable of the inverter
Remote HMI frame	: Accessory
Remote HMI degree of protection	: IP56

Ambient conditions

Enclosure	: IP20
Degree of pollution	: 2
Temperature	
- Minimum	: -10 °C / 14 °F
- Nominal [4]	: 45 °C / 113 °F
Current reduction factor [5]	: 2 % per °C of 45 (113) to 55 °C (131 °F)
Relative humidity (non-condensing)	
- Minimum	: 5%
- Maximum	: 90%
Altitude	
- Rated conditions	: 1000 m (3281 ft)
- Maximum altitude allowed for operation	: 4000 m (13123 ft)
Current Reduction factor[6]	
- Current derating factor (for altitudes above rated)	: 1% for each 100 m above
- Voltage derating factor (for altitudes above 2000 m / 6562 ft)	: 1,1% for each 100 m above

Sustainability policies

RoHS	: Yes
Conformal Coating	: 3C2

Dimensions

Size	: G
Height	: 1264 mm / 49.8 in
Width	: 535 mm / 21.1 in
Depth	: 426 mm / 16.8 in
Weight	: 258 kg / 568.8 lb

Mechanical installation

Mounting position	: Surface or flange
Fixing screw	: M10
Tightening torque	: 37 N.m / 27.31 lb.ft
Allows side-by-side assembly	: No
Minimum spacing around the inverter	
- Top	: 150 mm / 5.91 in
- Bottom	: 250 mm / 9.84 in
- Front	: 20 mm / 0.78 in
- Side	: 80 mm / 3.15 in

Electrical connections

Cable gauges and tightening torque:

	Recommended cable gauge to 75 °C (167 °F)	Recommended tightening torque
Power	2x 120 mm ² (2x 4/0 AWG) HD	Power 60,0 N.m (44,28 lb.ft) and braking 10,0 N.m (7,38 lb.ft)
Braking	Not applicable	Power 60,0 N.m (44,28 lb.ft) and braking 10,0 N.m (7,38 lb.ft)
Grounding	150 mm ² (300 AWG)	10 N.m / 7.38 lb.ft
Control	0,5 to 1,5 mm ² (20 to 14 AWG)	0,5 N.m / 0.37 lb.ft

Additional specifications

Maximum breaking current	: Not available
Minimum resistance for the brake resistor	: Not available
Recommended aR fuse	: FNH3-800K-A
Recommended aR fuse	: Not applicable
Recommended circuit breaker	: To define
Recommended circuit breaker	: Not applicable

Standards

Safety	<ul style="list-style-type: none"> - UL 508C - Power conversion equipment. - UL 840 - Insulation coordination including clearances and creepage distances for electrical equipment. - EN 61800-5-1 - Safety requirements electrical, thermal and energy. - EN 50178 - Electronic equipment for use in power installations - EN 60204-1 - Safety of machinery. Electrical equipment of machines. Part 1: General requirements. Note: To have a machine in accordance with this standard, the machine manufacturer is responsible for installing an emergency stop device and supply disconnecting device. - EN 60146 (IEC 146) - Semiconductor converters.
--------	---



- EN 61800-2 - Adjustable speed electrical power drive systems - Part 2: General requirements - Rating specifications for low voltage adjustable frequency AC power drive systems.

Electromagnetic compatibility

EN 61800-3 - Adjustable speed electrical power drive systems - Part 3: EMC product standard including specific test methods.
 - EN 55011 - Limits and methods of measurement of radio disturbance characteristics of industrial, scientific and medical (ISM) radio-frequency equipment.
 - CISPR 11 - Industrial, scientific and medical (ISM) radio-frequency equipment - Eletromagnetic disturbance characteristics - Limits and methods of measurement.
 - EN 61000-4-2 - Eletromagnetic compatibility (EMC) - Part 4: Testing and measurement techniques - Section 2: Eletrostatic discharge immunity test.
 - EN 61000-4-3 - Eletromagnetic compatibility (EMC) - Part4: Testing and measurement techniques - Section 3: Radiated, radio-frequency, electromagnetic field immunity test.
 - EN 61000-4-4 - Eletromagnetic compatibility (EMC) - Part4: Testing and measurement techniques - Section 4: Electrical fast transient/burst immunity test.
 - EN 61000-4-5 - Eletromagnetic compatibility (EMC) - Part4: Testing and measurement techniques - Section 5: Surge immunity test.
 - EN 61000-4-6 - Eletromagnetic compatibility (EMC) - Part4: Testing and measurement techniques - Section 6: Immunity to conducted disturbances, induced by radio-frequency fields.

Mechanical construction

- EN 60529 - Degrees of protection provided by enclosures (IP code).
 - UL 50 - Enclosures for electrical equipment.
 - EN 60529 e UL 50

Certifications

Notes

- 1) Orientative motor power, valid for WEG Motors standard of IV poles. The correct sizing must be done according to the nominal current of the motor used, which must be less than or equal to the rated output current of the inverter;
- 2) Braking resistor is not included;
- 3) With category for emission level conducted;
- 4) Without derating and with minimum spaces;
- 5) For temperatures above the nominal and maximum temperature (with derating of current and minimum spaces);
- 6) For altitude over of specified;
- 7) All images are merely illustrative;
- 8) For more information, see the users manual of the CFW-11 (size G).

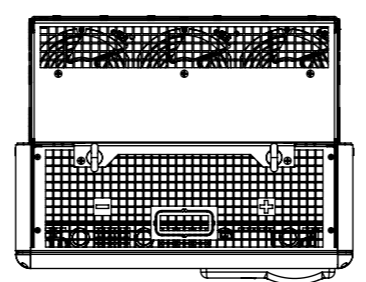
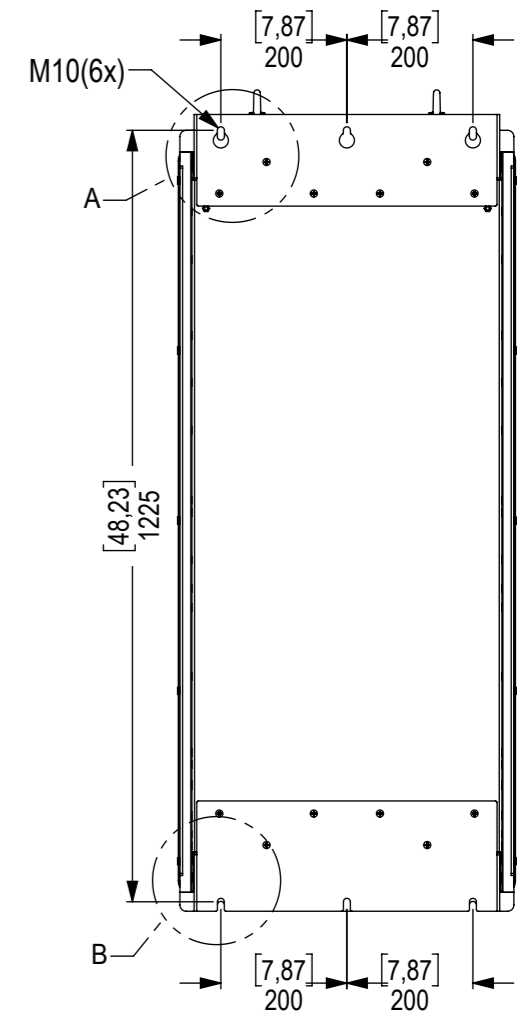
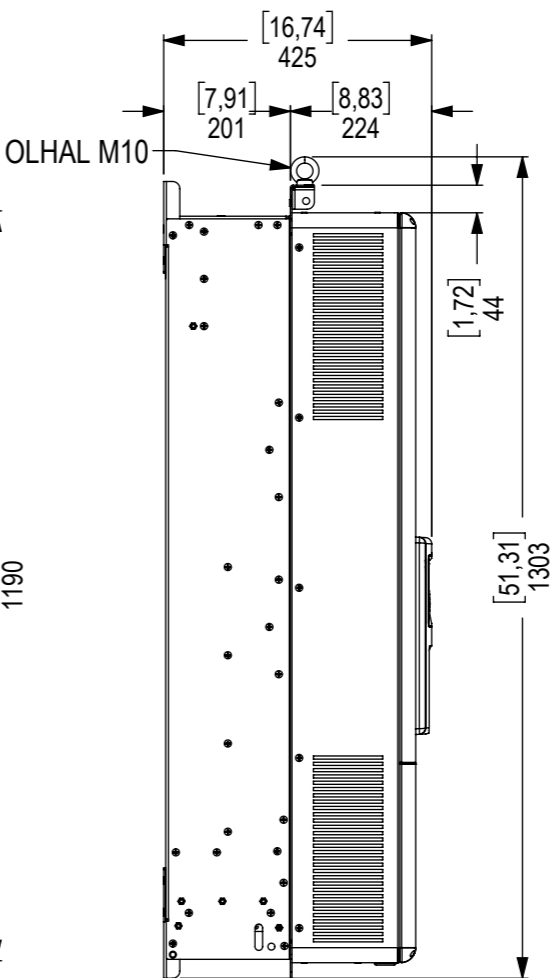
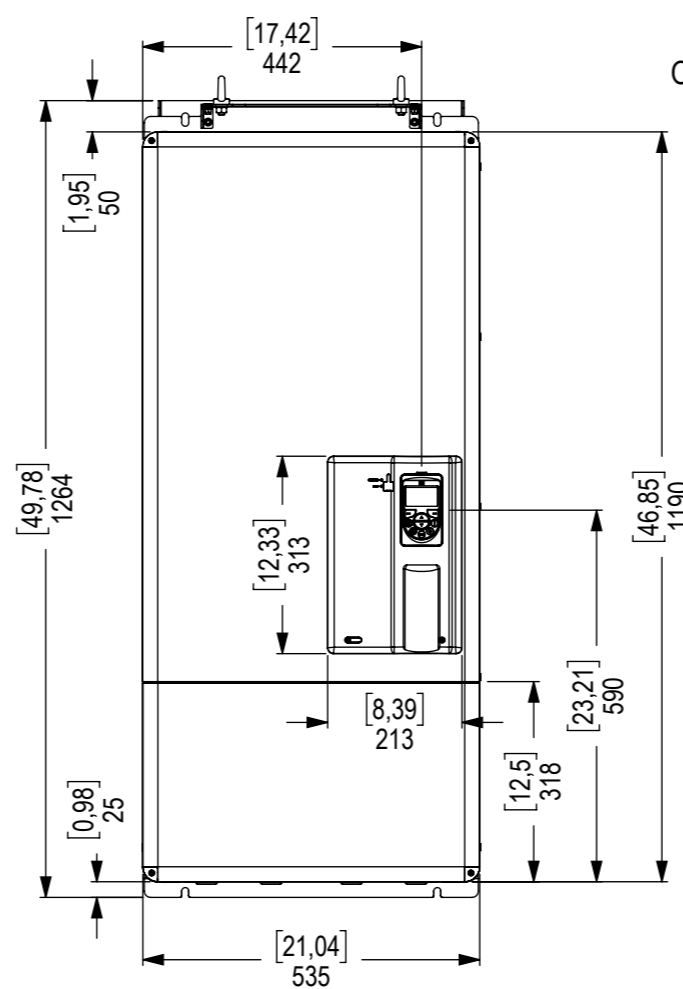
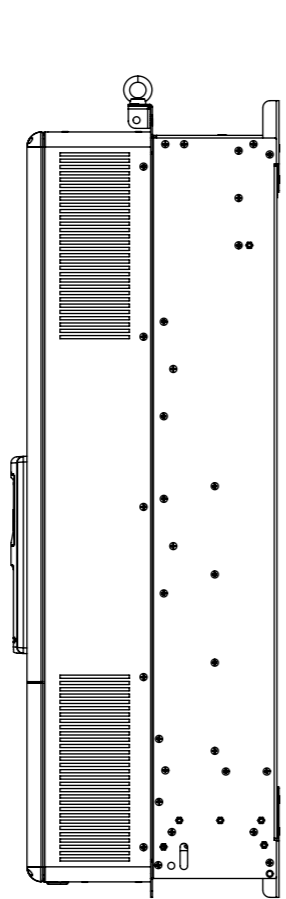
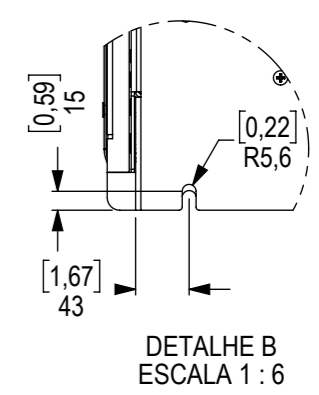
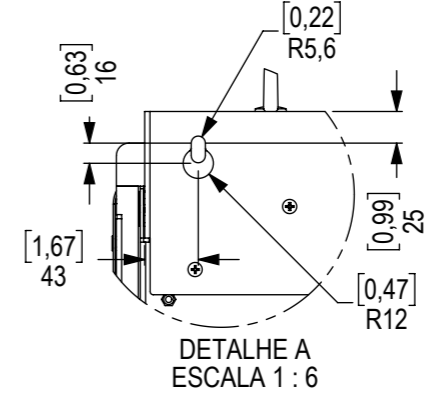
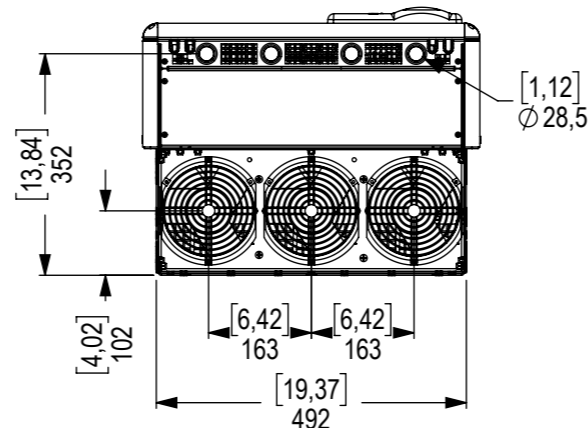
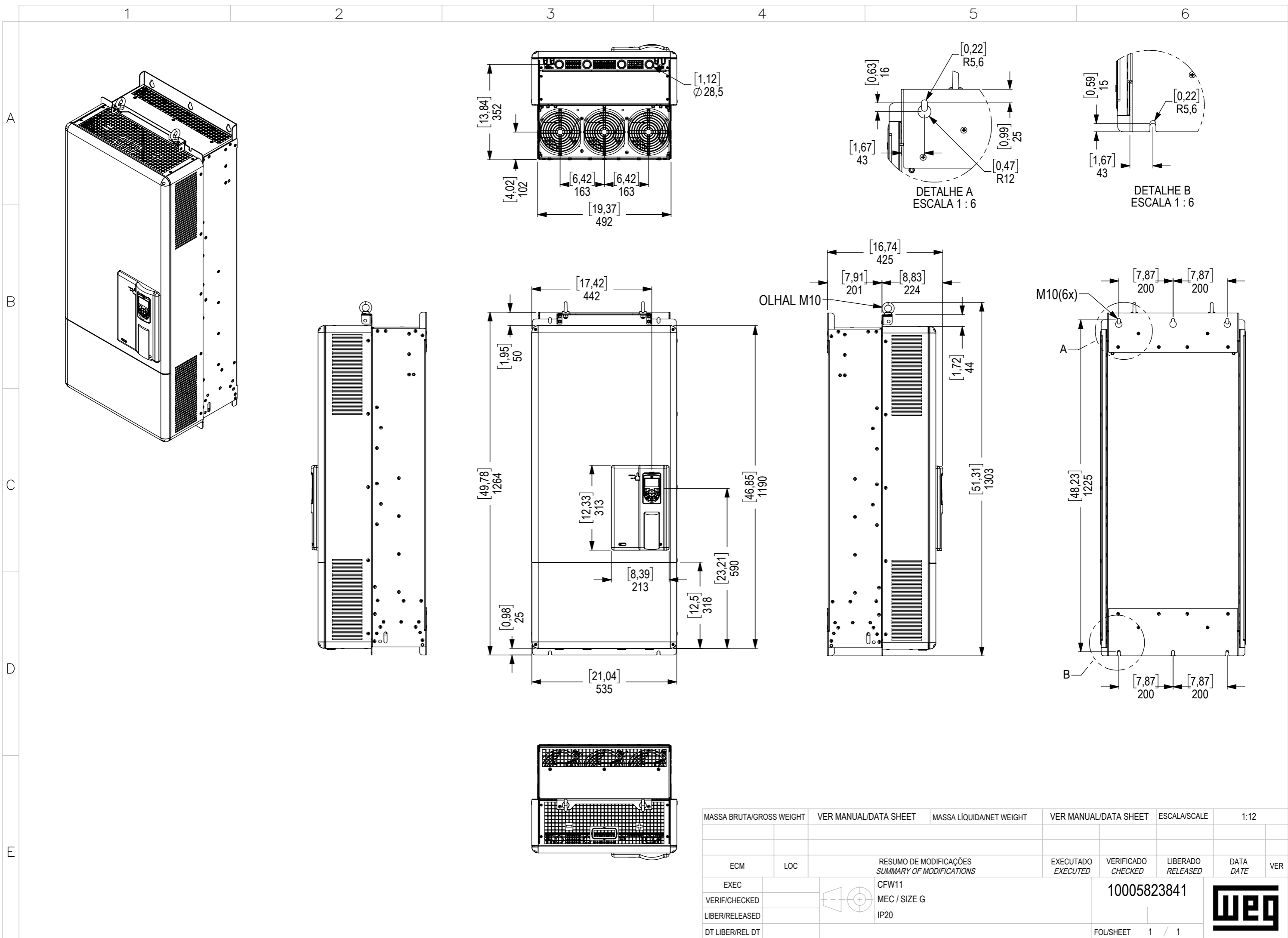

MASSA BRUTA/GROSS WEIGHT	VER MANUAL/DATA SHEET	MASSA LÍQUIDA/NET WEIGHT	VER MANUAL/DATA SHEET	ESCALA/SCALE	1:12			
ECM	LOC	RESUMO DE MODIFICAÇÕES SUMMARY OF MODIFICATIONS		EXECUTADO EXECUTED	VERIFICADO CHECKED	LIBERADO RELEASED	DATA DATE	VER
EXEC		CFW11		10005823841				
VERIF/CHECKED		MEC / SIZE G						
LIBER/RELEASED		IP20						
DT LIBER/REL DT				FOL/SHEET 1 / 1				

