



3300 Series Rugged Seal Meter Relay

- Designed for Type J and Type K Thermocouple Inputs with Dual Scale Dial for Celsius and Fahrenheit
- Electronic Cold Junction Compensation
- Thermocouple Resistance from 0 to 100 ohms
- Metal Cased and Shielded
- Calibration Not Affected by Steel Panel Mounting
- Rugged Metal Case for Rigorous Environments
- Commercially-Sealed, Moisture and Dust Proof
- Amplifier Input



Model Number	Size	Meter Movement
3324AIXA	4-1/2"	Annular

For complete temperature control, look to the Model 3324AIXA Temperature Meter Relay. The 3300 Series features high impedance, solid-state circuitry that eliminates thermocouple lead length adjustments. Each unit has electronic cold junction compensation to ensure accurate compensation for differences between unit temperature and ice point. Type J and K thermocouple inputs with resistances from 0 to 100 ohms may be used with the meter. Thermocouples are not included; see Accessory Section for details. The 3324AIXA meter relay

is available for either single or dual set point control and can be used for either Celsius or Fahrenheit applications. They incorporate an amplifier input which drives a rugged 1 milliamp high torque meter movement. The die cast metal case is shielded and can be mounted in steel panels without effect to the controller's calibration. In addition, each controller is moisture, dust, and dirt proof and recommended for use in wash-down areas. This style meter is ideal for many other electrical functions. See the "Function Reference Table."

Dimensions and Compatibility

1 = Panel Meter Cut-out Dimensions

4-1/2"- Model 3324AIXA-SSP & 3324AIXA-DSP

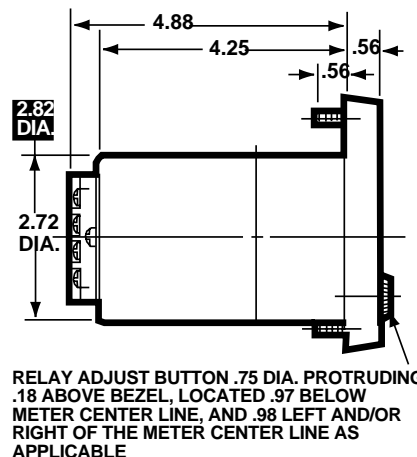
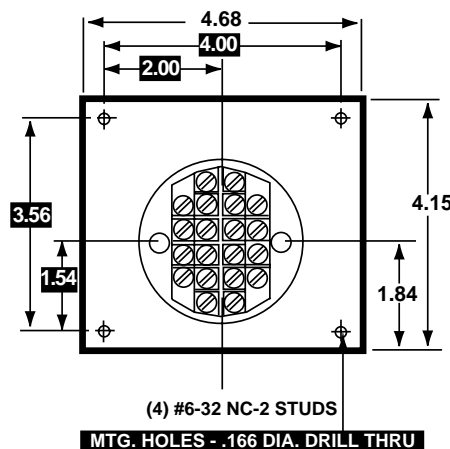

Specifications

Accuracy: $\pm 2\%$ of full scale (F.S.)
Movement: Annular, self-shielding
Suspension: Pivot and jewel

Adjustments: Single, 0-100% of arc; double, low limit 0-95% of arc; high limit, 5-100% of arc
 Adjustable to within 4° of each other

Switching: Within 1% of indication
Differential: "On," "Off" difference is within 0.5% of F.S.
Auto/Manual Reset: Latching function can be enabled independently for each relay by removing jumpers on terminal block.

Contacts/Output Relays: DPDT relay contacts for each control point
 Each set of contacts rated at 5 amps, 115 VAC.

Frequency Response: 50-1000Hz

Power: 108-132 VAC, 50-400Hz
Operating Temperature: -4°F to $+149^\circ\text{F}$ (-20°C to $+65^\circ\text{C}$)
Circuit-to-Ground Voltage: 250 RMS maximum

Case: Sealed metal, plastic window
Shielding: Calibration is unaffected by magnetic panel mounting.

Response Time: 1.5 seconds maximum
Overload (1 sec.): 10 times F.S.
Overload (Continuous): 1.5 times F.S.
Repeatability: 2%

Dial: Sharp clear scale. Each dial arc is calibrated to track the specific type of movement used.

Resistance: $\pm 15\%$
Tracking: $\pm 3\%$

Wiring Diagram

REAR VIEW OF HEADER

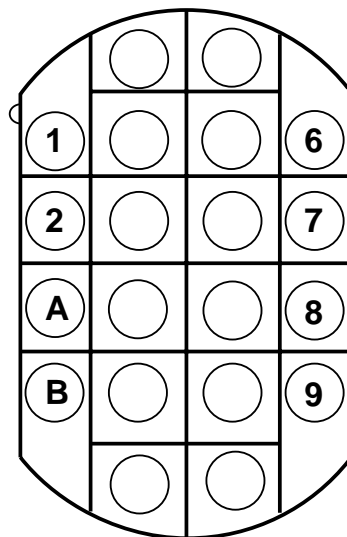

TERMINAL DESIGNATIONS

- A. + SIGNAL INPUT
 B. - SIGNAL INPUT
1. AUTO/MAN. RESET HI SET POINT
 2. SHORT FOR AUTO
 6. AUTO/MAN. RESET LO SET POINT
 7. SHORT FOR AUTO
 8. 120 VAC $\pm 10\%$
 50-400 Hz
 9. 4 VA

Input Signal: Input to be monitored is connected to terminals A(+) and B (-).

Input Power: The power source used is 120VAC $\pm 10\%$, 50 to 400Hz. The power requirement is nominally 4VA. Connect power source to terminals 8 and 9.

Auto/Manual Reset

There are two modes of relay logic available in the 3324AIXA: Automatic Reset and Manual Reset. Auto Reset is a simple on-off action in which the high set point relay is energized when the pointer exceeds the high set point, and is automatically de-energized when the pointer again drops below the set point. The low set point relay is energized when the pointer drops below the low set point, and is automatically de-energized again when the pointer rises above the low set point.

Manual Reset is a latching action. When the pointer exceeds the high set point, the high set point relay energizes and is latched out. It can only

pull in after the pointer drops below the high set point and the operator presses a reset button. In the manual reset mode the low set point relay is likewise latched out until the pointer is above the low set point and the operator presses a reset button.

Installing Auto/Manual Reset

If Auto Reset is desired, simply connect a jumper between terminals 1 and 2 for the high set point or 6 and 7 for the low set point.

If Manual Reset is desired, connect a normally-open SPST push-button switch to the terminals as shown in the terminal designation diagram.

On a dual set point unit, the Auto or Manual mode may be selected for either set point, independent of the mode used for the other set point. If both set points of a dual set point unit are connected for Manual Reset, two independent push buttons are usually used. However, one master reset button may be used for both set points provided it is a double pole switch with no electrical connection between poles.

Relays

Relays can be used to turn on or turn off power to a process that the 3324AIXA is monitoring. A light can be turned on when a set point is exceeded, alerting the operator to change in condition in the process. The controller's relays for both single and dual set point meters are double pole, double throw relays.

High Set Point: The high set point relay contacts (on both single and dual set point meters) are de-energized when the pointer is above the desired set point. For normally open relay connection use terminals 11 and 14. Terminals 12 and 15 are moving contacts. Terminals 13 and 16 are normally closed.

Low Set Point Connection: The low set point relay contacts (appear on dual set point meters only) are de-energized when the pointer is below desired set point. For normally open relay connection use terminals 21 and 24. Terminals 22 and 25 are moving contacts or common. Use terminals 23 and 26 for normally closed relays.

REAR VIEW OF HEADER

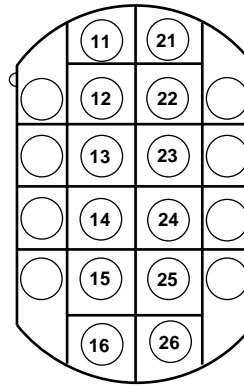

TERMINAL DESIGNATIONS

- | | | |
|--------|---|---|
| 11. NO | } | HIGH SET POINT.
RELAY IS
DE - ENERGIZED
WITH POWER POINTER
ABOVE SET POINT. |
| 12. C | | |
| 13. NC | | |
| 14. NO | } | LOW SET POINT.
RELAY IS
DE - ENERGIZED
WITH POWER POINTER
BELOW SET POINT. |
| 15. C | | |
| 16. NC | | |
| 21. NO | } | LOW SET POINT.
RELAY IS
DE - ENERGIZED
WITH POWER POINTER
BELOW SET POINT. |
| 22. C | | |
| 23. NC | | |
| 24. NO | } | LOW SET POINT.
RELAY IS
DE - ENERGIZED
WITH POWER POINTER
BELOW SET POINT. |
| 25. C | | |
| 26. NC | | |

RATED CIRCUIT TO GROUND VOLTAGE: 250V AC RMS MAX.
ALL RELAY CONTACT POSITIONS SHOWN WITH RELAYS DE-ENERGIZED

Application Example

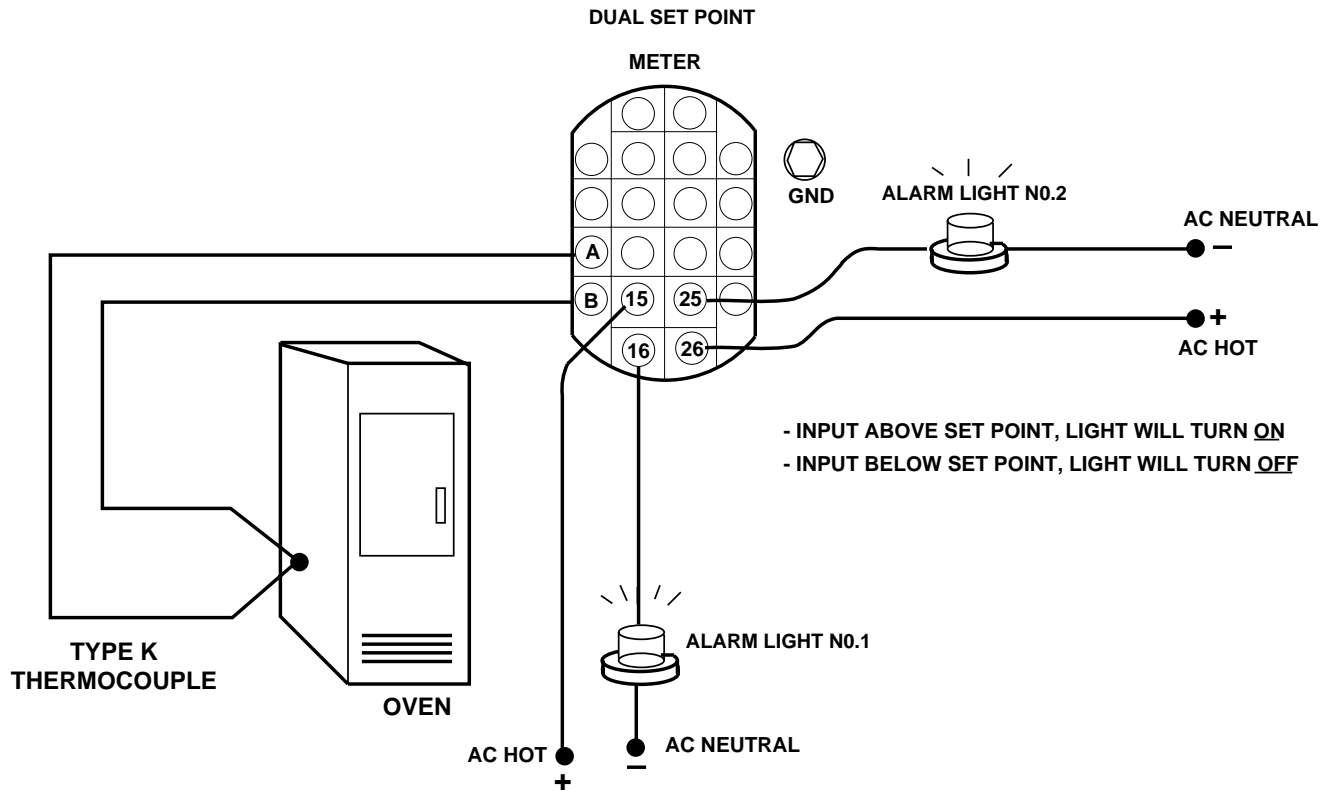

A kiln oven is used to test military aircraft wiring harnesses. The harness test procedure specifies an oven temperature of 2000°F. An alarm is specified, to alert the operator if the oven temperature either exceeds 2100°F or falls below 2000°F, or in the event of a thermocouple failure.

A type K thermocouple is installed with a Model 3324AIXA dual set point meter relay. The set points are adjusted appropriately to the specified requirements. If the temperature goes above 2100°F or drops below

2000°F the relay will de-energize and will turn on an alarm light that will alert the maintenance team to this change in condition.

The thermocouple lead wires are connected to Terminal A(+) and Terminal B(-) on back of the controller. The relay contacts for a normally closed state are Terminals 15 (common) and 16 (normally closed) for the Hi set point and Terminals 25 (common) and 26 (normally closed) for the Low set point.

