

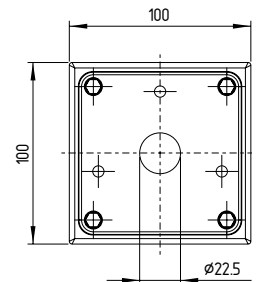

**EN** Operating instructions. . . . .pages 1 to 2  
Original

**Dimensions**

All measurements in mm.

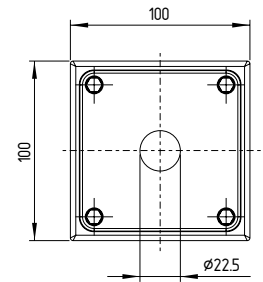
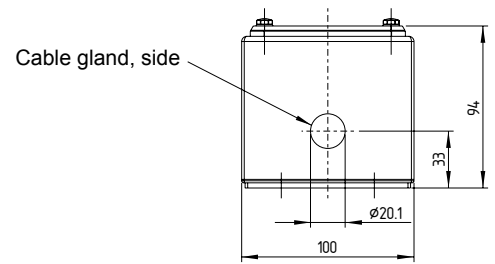

Special version for NSK protective collar



Tightening torque of the fixing screws, guard collar  
NSK 1 Nm ± 0.1 Nm

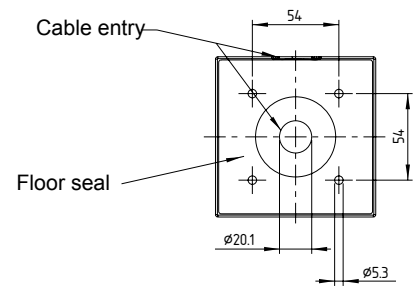

The cable entry in the enclosure floor is standard. Devices with the addition .1 or .2 in the type designation have side cable entry instead of floor entry (.3).

**Mounting**



In hygiene-sensitive applications, the assembly housing must be fitted with an offset angle of at least 3° in order to ensure that water and other liquids can run off.



Assembly must be carried out on a grease-free, level surface with suitable M5 cheese-head screws. In hygiene applications, it must be ensured that cleaning and inspection for damage can be carried out from all sides. As such, we recommend a clearance of at least 10 cm to other machine parts.

**Enclosure for surface mounting**

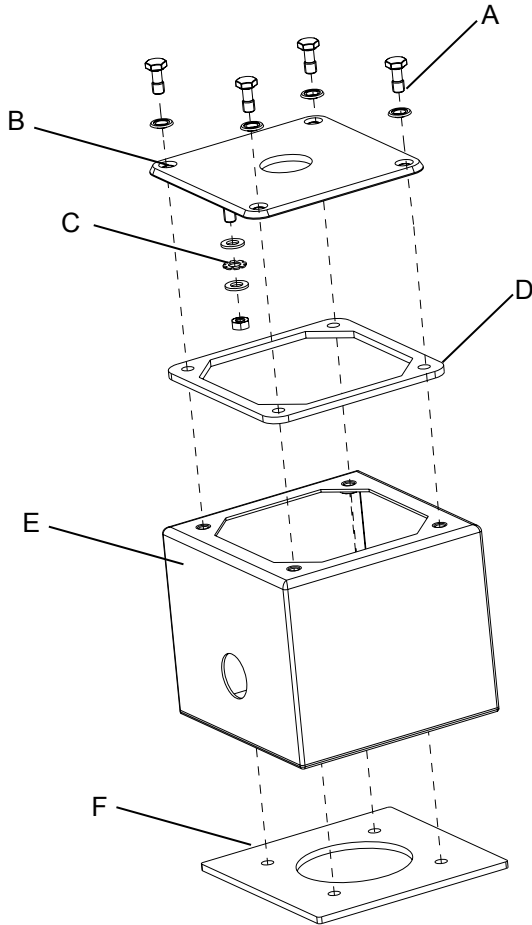

Tightening torque for M5 fixing screws and earth connections 1.3 Nm ± 0.1 Nm.

**Key**

- A: Cover fixing screws with gasket
- B: Enclosure cover
- C: Earth connections
- D: Cover gasket
- E: Enclosure lower section
- F: Floor seal

**Supply kit**

A: Supply kit with 4x cover fixing screws with gasket

C: Earth connection supply kit comprising 6x washers, 3x serrated lock washers and 3x nuts

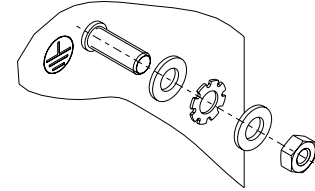
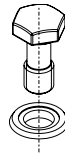

Tightening torque 1.3 Nm ± 0.1 Nm

**Maintenance**



Only approved cleaning agents are permitted for cleaning. We would be happy to provide a list on request. Cleaning must not be carried out above 80 °C. After cleaning, an inspection must be carried out from all sides to check for damage. Faulty devices/parts must be replaced immediately.

**K. A. Schmersal GmbH & Co. KG**  
 Möddinghofe 30, D - 42279 Wuppertal  
 Postfach 24 02 63, D - 42232 Wuppertal

Phone: +49 - (0)2 02 - 64 74 - 0  
 Telefax: +49 - (0)2 02 - 64 74 - 1 00  
 E-Mail: [info@schmersal.com](mailto:info@schmersal.com)  
 Internet: <http://www.schmersal.com>

