



**EN** Operating instructions. . . . .pages 1 to 8  
Original

**Content**

**1 About this document**

1.1 Function . . . . . 1

1.2 Target group: authorised qualified personnel. . . . . 1

1.3 Explanation of the symbols used . . . . . 1

1.4 Appropriate use . . . . . 1

1.5 General safety instructions . . . . . 1

1.6 Warning about misuse . . . . . 1

1.7 Exclusion of liability . . . . . 2

**2 Product description**

2.1 Ordering code . . . . . 2

2.2 Special versions. . . . . 3

2.3 Purpose . . . . . 3

2.4 Technical data . . . . . 3

**3 Mounting**

3.1 General mounting instructions for E and N programme. . . . . 4

3.2 General mounting instructions for R programme. . . . . 5

3.3 Dimensions . . . . . 5

**4 Electrical connection**

4.1 General information for electrical connection. . . . . 6

4.2 Contact variants of contact system . . . . . 6

**5 Set-up and maintenance**

5.1 Functional testing. . . . . 6

5.2 Maintenance . . . . . 6

**6 Disassembly and disposal**

6.1 Removal of E, N and R programme. . . . . 6

6.2 Disposal . . . . . 6

**7 EU Declaration of conformity**

**1. About this document**

**1.1 Function**

These operating instructions provide all the information required for mounting, set-up and commissioning to ensure the safe operation and disassembly of the safety switchgear. The operating instructions must be available in a legible condition and a complete version in the vicinity of the device.

**1.2 Target group: authorised qualified personnel**

All operations described in this operating instructions manual must be carried out by trained specialist personnel, authorised by the plant operator only.

Please make sure that you have read and understood these operating instructions and that you know all applicable legislations regarding occupational safety and accident prevention prior to installation and putting the component into operation.

The machine builder must carefully select the harmonised standards to be complied with as well as other technical specifications for the selection, mounting and integration of the components.

**1.3 Explanation of the symbols used**



**Information, hint, note:**

This symbol is used for identifying useful additional information.



**Caution:** Failure to comply with this warning notice could lead to failures or malfunctions.

**Warning:** Failure to comply with this warning notice could lead to physical injury and/or damage to the machine.

**1.4 Appropriate use**

The products described here were developed to adopt control and display functions as part of a complete system or machine. It is the responsibility of the manufacturer of a machine or plant to ensure the correct functionality of the entire machine or plant.

The products must be exclusively used in accordance with the versions listed below or for the applications authorised by the manufacturer. Detailed information regarding the range of applications can be found in the chapter "Product description".

**1.5 General safety instructions**

The user must observe the safety instructions in this operating instructions manual, the country specific installation standards as well as all prevailing safety regulations and accident prevention rules.



Further technical information can be found in the Schmersal catalogues or in the online catalogue on the Internet: [www.schmersal.net](http://www.schmersal.net).

The information contained in this operating instructions manual is provided without liability and is subject to technical modifications.

There are no residual risks, provided that the safety instructions as well as the instructions regarding mounting, commissioning, operation and maintenance are observed.

**1.6 Warning about misuse**



In case of inadequate or improper use or manipulations of the component, personal hazards or damage to machinery or plant components cannot be excluded. The relevant requirements of the standard ISO 13850 must be observed.

### 1.7 Exclusion of liability

We shall accept no liability for damages and malfunctions resulting from defective mounting or failure to comply with this operating instructions manual. The manufacturer shall accept no liability for damages resulting from the use of unauthorised spare parts or accessories. For safety reasons, invasive work on the device as well as arbitrary repairs, conversions and modifications to the device are strictly forbidden; the manufacturer shall accept no liability for damages resulting from such invasive work, arbitrary repairs, conversions and/or modifications to the device.

## 2. Product description

### 2.1 Ordering code

These operating instructions apply to the following types and programs:

#### 2.1.1 Device heads of the command devices

| Basic component                                     | Description  |
|---|--|
| <b>Pushbuttons and the illuminated pushbuttons:</b> |  |
| ①DT⑧②   | Pushbutton   |
| ①DM②  | Pushbutton with diaphragm for dust protection                              |
| ①DL⑧②   | Illuminated pushbutton   |
| ①DLM②   | Illuminated pushbutton with diaphragm for dust protection                  |
| <b>Indicator light:</b>                             |  |
| ①ML②  | With flat collar   |
| ①MLH②   | With high collar   |
| <b>Mushroom head impact button:</b>                 |  |
| ①DP③⑧②  | without latching   |
| ①DTP③⑧②   | Without latching (only N programme)  |
| ①DLP③⑧②   | Illuminated, without latching (only N programme)                           |
| ①DRR③⑧②   | with latching, unlock by turning and pulling (pulling only in N programme) |
| ①DRZ③⑧②   | With latching, pull to unlock  |
| <b>Selector switch:</b>                             |  |
| <b>- with 2 positions:</b>                          |  |
| ①WS21④⑤   | 2 maintained positions   |
| ①WT21④⑤   | 1 momentary position   |
| <b>- with 3 positions:</b>                          |  |
| ①WS32④⑤   | 3 maintained positions   |
| ①WT32④⑤   | 2 momentary positions, left and right                                      |
| ①WST32④⑤  | switching, latching  |
| ①WTS32④⑤  | latching, switching  |
| <b>Key-operated selector switch:</b>                |  |
| <b>- with 2 positions:</b>                          |  |
| ①SS21S⑦   | 2 maintained positions   |
| ①ST21S⑦   | 1 momentary position   |
| <b>- with 3 positions:</b>                          |  |
| ①SS32S⑥   | 3 maintained positions   |
| ①ST32S⑥   | 2 momentary positions, left and right                                      |
| ①SST32S⑥  | switching, latching  |
| ①STS32S⑥  | latching, switching  |
| <b>Blanking plug for command device position:</b>   |  |
| NB, MBN, BN   | Blanking plug  |

| No. | Option                                 | Description |
|-----|--|-------------|
| ①   | <b>Command and signalling devices:</b> |             |
|     | E                                      | "E" program |
|     | N                                      | "N" program |
|     | R                                      | "R" program |
| ②   | <b>Colour of button surface:</b>       |             |
|     | GB                                     | yellow      |
|     | RT                                     | red         |
|     | GN                                     | green       |
|     | WS                                     | white       |
|     | BL                                     | blue        |
|     | GR                                     | grey        |
| SW  | Black (not for illuminating devices)   |             |

| No. | Option  | Description     |
|-----|---|-----------------|
| ③   | <b>Head diameter of mushroom head impact button</b> |                 |
|     | 30  | 30 mm           |
|     | 35  | 35 mm           |
|     | 40  | 40 mm           |
|     | 42  | 42 mm           |
|     | 45  | 45 mm           |
|     | 50  | 50 mm           |
|     | 55  | 55 mm           |
| 70  | 70 mm   |                 |
| ④   | <b>Toggle length in mm:</b>                         |                 |
|     | Without   | Short toggle    |
|     | .1  | Long toggle     |
| ⑤   | <b>Colour of toggle</b>                             |                 |
|     | Without   | grey            |
|     | WS  | white           |
| ⑥   | <b>Key-withdrawal position (3 positions):</b>       |                 |
|     | 1   | Position left   |
|     | 2   | Position middle |
|     | 3   | Position right  |
| ⑦   | <b>Key-withdrawal position (2 positions):</b>       |                 |
|     | 1   | Position left   |
|     | 2   | Position right  |
| ⑧   | <b>Colour of diaphragm (only N programme):</b>      |                 |
|     | Without   | white           |
|     | GR/   | black           |
|     | BL/   | blue            |

#### 2.1.2 Contact elements of EF contact system (for E and N programme)

| Basic component                      | Description  |
|--------------------------------------|--|
| <b>- with screw terminals</b>        |  |
| EF10.③                               | Contact element NC                                       |
| EF02.③                               | Contact element NO                                       |
| EF1①0.③                              | Double contact element 2 NC                              |
| EF02②.③                              | Double contact element 2 NO                              |
| EF10②.③                              | Double contact element NC/NO                             |
| EF10②S.③                             | Double contact element NC/NO contacts with safety spring |
| <b>- with flat plug-in connector</b> |  |
| EF10F.③                              | Contact element NC                                       |
| EF02F.③                              | Contact element NO                                       |
| EF1①0F.③                             | Double contact element 2 NC                              |
| EF02②F.③                             | Double contact element 2 NO                              |
| EF10②F.③                             | Double contact element NC/NO                             |
| EF10②SF.③                            | Double contact element NC/NO contacts with safety spring |
| <b>- with cage clamps</b>            |  |
| EFK10.③                              | Contact element NC                                       |
| EFK02.③                              | Contact element NO                                       |
| EFK1①0.③                             | Double contact element 2 NC                              |
| EFK02②.③                             | Double contact element 2 NO                              |
| EFK10②.③                             | Double contact element NC/NO                             |

| No. | Option | Description   |
|-----|--------|---|
| ①   | 1      | <b>Normally-closed contact, with approx. contact travel in mm</b> |
|     | 2      |   |
|     | 3      |   |
| ②   | 1      | <b>Normally-open contact, with approx. contact travel in mm</b>   |
|     | 2      |   |
|     | 3      |   |
|     | 4      |   |
| ③   | 1      | <b>Mounting position on mounting flange / terminal ID</b>         |
|     | 2      |   |
|     | 3      |   |

2.1.3 Contact elements of RF contact system (for R programme)

| Basic component | Description            |
|-----------------|------------------------|
| RF①②③           | - with screw terminals |
| RF0②③           | Contact element NC     |
|                 | Contact element NO     |

| No. | Option  | Description  |
|-----|---------|--|
| ①   | 1       | Normally-closed contact, with approx. contact travel in mm |
| ②   | 3       | Normally-open contact, with approx. contact travel in mm   |
| ③   | Without | Mounting position 1st level / terminal ID                  |
|     | .1      | Mounting position 2nd level / terminal ID                  |

2.1.4 Light elements of EF contact system (for E and N programme)

| Basic component    | Description   |
|--------------------|---|
| EL①③               | Voltage sensor for lamps Ba9S                         |
| ELE①③              | Voltage sensor for LED Ba9S                           |
| ELT③/③             | Voltage sender with transformer (primary/secondary)   |
| ELDE.N②③           | Light element with screw terminals and integrated LED |
| ELDEK②③            | Light element with cage clamps and integrated LED     |
| ELDE.N-②-②-②-24VDC | 3 colour LED module with screw terminals              |

| No. | Option        | Description            |
|-----|---------------|------------------------|
| ①   | Without       | screw terminal         |
|     | F             | Flat plug-in connector |
|     | K             | Cage clamps            |
| ②   | GB            | yellow                 |
|     | RT            | red                    |
|     | GN            | green                  |
|     | WS            | white                  |
|     | BL            | blue                   |
| ③   | 6             | Voltage 6 V            |
|     | without or 24 | Voltage 24 V           |
|     | 48            | Voltage 48 V           |
|     | 230           | Voltage 115...230 VAC  |

2.1.5 Light elements of RF contact system (for R programme)

| Basic component | Description   |
|-----------------|---|
| RL              | Voltage sensor for lamps Ba9S                               |
| RLDEWS24        | Light element with screw terminals and integrated white LED |

2.2 Special versions

For special versions, which are not listed in the order code below 2.1, these specifications apply accordingly, provided that they correspond to the standard version.

2.3 Purpose

The devices described in these operating instructions are not suitable for emergency stop applications. Emergency stop command devices are described in a separate set of operating instructions.

The devices described here are designed to be mounted in control panels or assembly housings. The command devices are only suitable for processing operation-relevant signals for purposes of machine control.

If sealing elements or dust protection membranes are not closed they could be damaged by cleaning agents and permanent UV exposure.

2.4 Technical data

Command and signalling devices:

General technical data:

|   |                                      |
|---|--------------------------------------|
| Design:   | round                                |
| Installation diameter:  | 22.3 mm                              |
| Spacing:  | 40 × 50 mm;                          |
| - selector switch, mushroom head  |                                      |
| impact button with latching:  | 50 × 60 mm                           |
| Front plate thickness:  | 1 ... 6 mm                           |
| - with identification label:  | 1...5 mm                             |
| Mounting position:  | any                                  |
| Switching frequency:  | 1,000/h                              |
| Actuating stroke:   | 4 mm ... 5 mm                        |
| Actuating force:  |                                      |
| - Pushbutton:   | approx. 1.5 N                        |
| - Pushbutton with diaphragm:  | approx. 2.0 N                        |
| - Illuminated pushbutton:   | approx. 1.5 N                        |
| - Mushroom head impact button:  | approx. 2.0 N                        |
| - Key-operated selector switch:   | approx. 0.2 N                        |
| - Spring-return rotary selector switch/<br>maintained spring-return rotary selector switch: | approx. 0.2 N                        |
| Mechanical life:  |                                      |
| - Push button:  | 1 x 10 <sup>6</sup> switching cycles |
| - Illuminated push button:  | 1 x 10 <sup>6</sup> switching cycles |
| - Palm button with detent:  | 1 x 10 <sup>5</sup> switching cycles |
| - Palm button without detent:   | 1 x 10 <sup>6</sup> switching cycles |
| - Key selector switch/button/selector switch:   | 1 x 10 <sup>5</sup> switching cycles |
| - Selector switch/button/<br>selector switch/key switch:                                    | 3 x 10 <sup>5</sup> switching cycles |
| Calotte/collar material:  |                                      |
| - N program:  | Plastic                              |
| - E and R program:  | Glass and plastic                    |
| Front ring material:  |                                      |
| - N program:  | Plastic chrome-plated                |
| - E and R program:  | Aluminium, anodised                  |
| Button material:  |                                      |
| - N program:  | Plastic                              |
| - E and R program:  | Aluminium, anodised                  |
| Selector switch grip material:  |                                      |
| - N program:  | Plastic                              |
| - E and R program:  | Plastic                              |
| Protection class:   |                                      |
| - N programme:  | IP67, IP69K                          |
| - E and R programme:  | IP65                                 |
| Ambient temperature:  | -25°C ... +75°C                      |
| - Selector switch, key-operated selector switch:  | 0°C ... +75°C                        |
| Fixing with mounting flange:  | ELM, EFM                             |
| Max. tightening torque of mounting flange:  | 0.6 Nm                               |
| Shock resistance to IEC 60068-2-27:   | < 50 g                               |
| Resistance to vibrations to EN 60068-2-6:   | 5 g                                  |
| Device designation:   |                                      |
| - Designation labels:   | Laser-etched or engraved             |
| - Symbols:  | Printed, laser-etched or engraved    |

## Contact/light element:

### General technical data:

|  |  |
|--|--|
| Standards:   | IEC 60947-5-1  |
| Switching frequency:                               | 1200/h   |
| Mechanical life:                                   | 10,000,000 operations  |
| Resistance to shock:                               | 30 g / 18 ms   |
| Resistance to vibration:                           | 20 g/10 ... 150 Hz   |
| Switching points:                                  | Depends on contact element used                                      |
| - NC contact:                                      | approx. 1 mm ... 3 mm  |
| - NO contact:                                      | approx. 2 mm ... 4 mm  |
| Switching system:                                  | Slow action,<br>NC contacts with positive break                      |
| Contact types:                                     | with galvanically separated contact bridges                          |
| Thermal test current $I_{the}$ :                   |  |
| - EF contact elements:                             | 10 A   |
| - RF contact elements:                             | 6 A  |
| Max. fuse rating:                                  |  |
| - EF contact elements:                             | 10 A gG  |
| - RF contact elements:                             | 6 A gG   |
| Suitable low voltage:                              |  |
| - EF contact elements:                             | 5 VDC / 3.2 mA   |
| - RF contact elements:                             | 5 VDC / 1 mA   |
| Utilisation category:                              |  |
| - EF contact elements:                             | AC-15: 250 V / 8 A<br>DC-13: 24 V / 5 A                              |
| - RF contact elements:                             | AC-15: 250 V / 6 A<br>DC-13: 24 V / 3 A                              |
| Rated insulation voltage $U_i$ :                   | 400 V  |
| Rated impulse withstand voltage $U_{imp}$ :        | 4 kV   |
| Degree of pollution:                               | 3  |
| Overvoltage category:                              | III  |
| Climatic resistance to DIN EN 60068:               | Part 2-30  |
| Temperature range:                                 | -25 °C ... + 60 °C   |
| Proof of positive opening:                         | 2.5 kV impulse voltage   |
| Positive break travel:                             | approx. 2 mm after the opening point                                 |
| Actuating force at end of stroke:                  | approx. 8 ... 15 N, depending<br>on contact element used             |
| Connection:  | Screw terminals<br>Plug-in terminals<br>Clamp terminals              |
| Cable sections:                                    |  |
| - Single core:                                     | 2 x (0.5 ... 2.5 mm <sup>2</sup> );                                  |
| - Fine wire with ferrules with protective collars: | 2 x (0.5 ... 1.5 mm <sup>2</sup> );                                  |
| - Flat connector:                                  | 6.3 mm x 0.8 mm /<br>2 x 2.8 mm x 0.8 mm                             |
| Tightening torque for the connecting screw:        | max. 1 Nm  |
| Material:  |  |
| - enclosure:                                       | plastic, glass-fibre reinforced thermoplastic,<br>self-extinguishing |
| - contacts:  | fine silver, spring bronze or brass carrier                          |
| Protection class:                                  |  |
| - Wiring compartments:                             | IP40   |
| - Terminals:                                       | IP20   |
|  | (with plug-in connector depending on the connector plug used)        |
| Approvals:   | cULus (with exception of cage clamps)                                |

## 3. Mounting

### 3.1 General mounting instructions for E and N programme

1. Mount control elements and mounting flange by tightening both screws of mounting flange using size 2 cross-point screwdriver (see fig. 1)



When tightening the screws, ensure the mounting flange is screwed on evenly and does not move.

2. Mount contact elements of EF contact system by snapping on in positions 1 to 3 to mounting flange (see Fig. 2). Middle position (pos. 3) is reserved for mounting lighting elements on devices with lights (see fig. 3).



On devices with lights, no plunger segments may be installed in the mounting flange. If using contact and light elements on the mounting flange, the light element must be mounted first and in the middle position (pos. 3).



Contact elements of the EF contact system must be fitted in the second locking position and must, therefore, lie flush on the mounting flange after fitting.

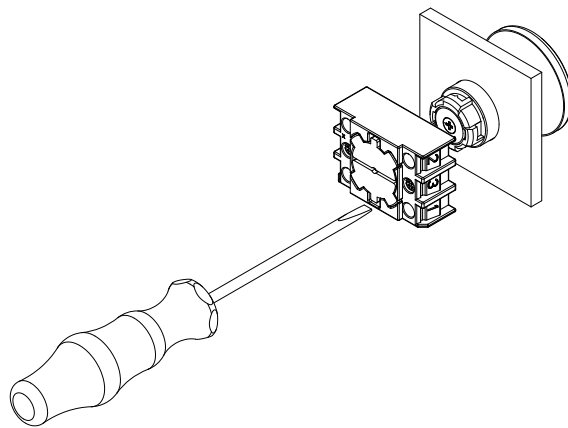

Fig. 1

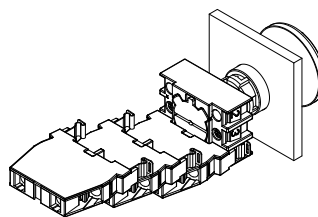

Fig. 2

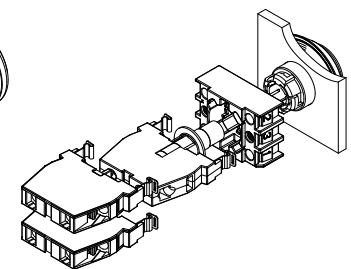

Fig. 3



Only fit onto clean and grease-free surface!

**3.2 General mounting instructions for R programme**

1. Mount control elements and mounting flange by tightening both screws of mounting flange using size 2 cross-point screwdriver (see section 3.1, Fig. 1)



When tightening the screws, ensure the mounting flange is screwed on evenly and does not move.

2. Mount contact elements of RF contact system by snapping on in positions 1 to 3 to mounting flange (see fig. 4). Middle position (pos. 3) is reserved for mounting lighting elements on devices with lights (see fig. 5).

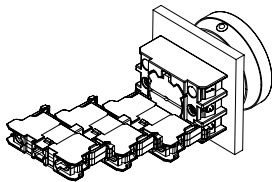

Fig. 4

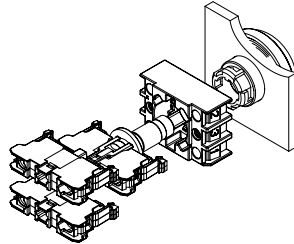

Fig. 5



On devices with lights, no plunger segments may be installed in the mounting flange.



Contact elements of the RF contact system are fitted in the first locking position and, therefore, lie flush on the mounting flange after fitting. If using contact and light elements on the mounting flange, the light element must be mounted first and in the middle position (pos. 3). No contact element may be mounted to the light element.



Only fit onto clean and grease-free surface!

**3.3 Dimensions**

All measurements in mm.

**EF contact system (for E and N programme)**

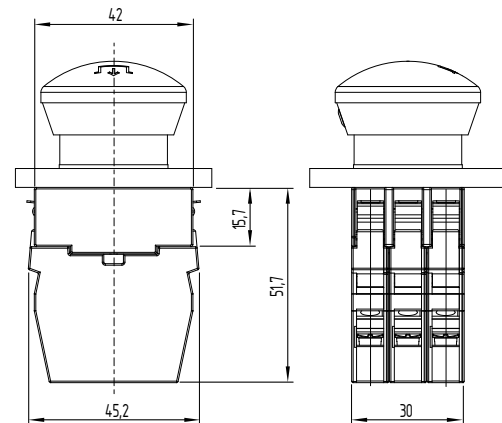

**RF contact system (for R programme)**

**Single row contact elements**

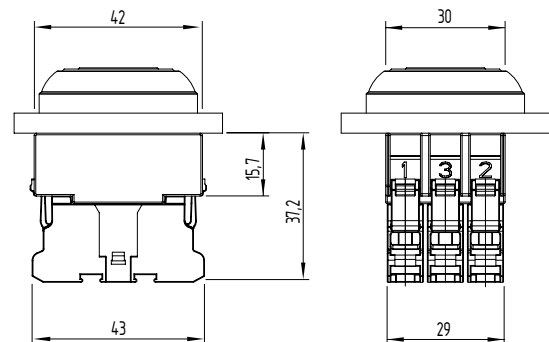

**Double row contact elements**

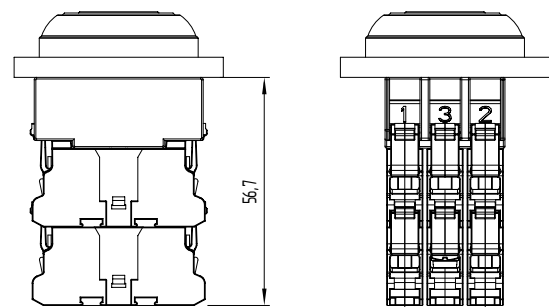

A maximum of 4 contact elements may be used on devices with latching. The fourth element must be mounted in the centre (pos. 3).

## Mounting flange and blanking plug

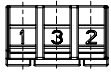

Fig. 6  
ELM / EFM

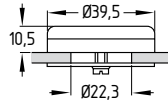
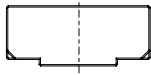

Fig. 7  
Blanking plug



The bevel on the mounting flange is indicated by position 1.

## 4. Electrical connection

### 4.1 General information for electrical connection



The electrical connection may only be carried out by authorised personnel in a de-energised condition.



After wiring, the contact elements must be cleaned (i.e. remove excess cables etc.).

The clamping screws of the contact elements are to be screwed in and tightened to 1 Nm.

### 4.2 Contact variants of contact system

Refer to ordering code, chapter 2.1



A mixture between command device programs and contact systems is not permissible on all devices.

## 5. Set-up and maintenance

### 5.1 Functional testing

The function of the component must be tested. The following conditions must be checked and met:

1. Correct fixing of the fitted component
2. Check the integrity of the connections
3. Check the command device for damage

### 5.2 Maintenance

A regular visual inspection and functional test, including the following steps, is recommended:

1. Check the correct fixing of the command device and the contact element
2. Remove particles of dust and soiling
3. Check the integrity of the connections

**Damaged or defective components must be replaced.**

## 6. Disassembly and disposal



The devices must be disassembled in a de-energised condition only.

### 6.1 Removal of E, N and R programme

1. Removal of the EF contact elements is carried out with the aid of a size 2 cross-point screwdriver (see fig. 8).  
Removal of the RF contact elements is carried out with the aid of a cross-point screwdriver with the recommended width of 5.5 mm (see Fig. 9).



With the light element mounted, the contact elements at pos. 1 and pos. 2 must be removed first. The light element is then removed.

2. Removal of the mounting flange is carried out by loosening the screws on the mounting flange. The mounting flange is then turned approx. 45° in anti-clockwise direction and removed (see fig. 10).

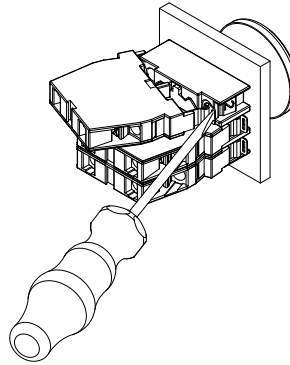

Fig. 8

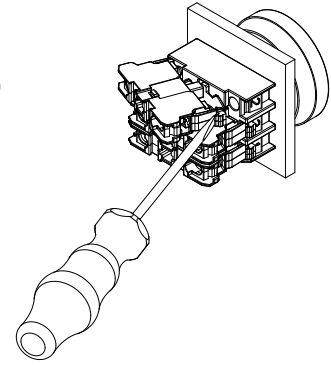

Fig. 9

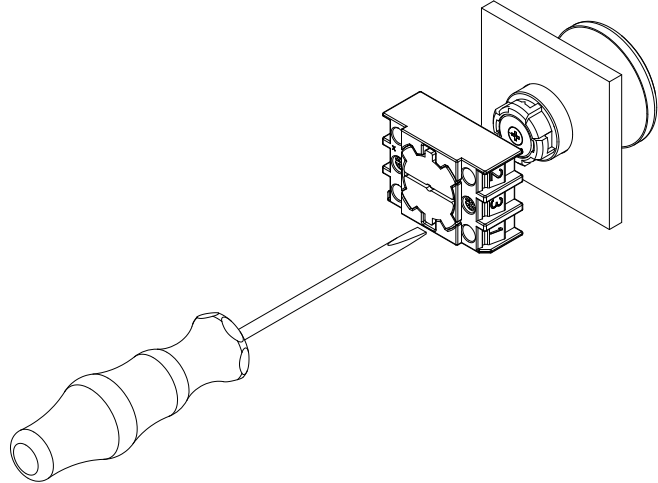

Fig. 10

### 6.2 Disposal

The switch must be disposed of in an appropriate manner in accordance with the national prescriptions and legislations.

7. EU Declaration of conformity

EU Declaration of conformity



Original  
K.A. Schmersal GmbH & Co. KG  
Möddinghofe 30  
42279 Wuppertal  
Germany  
Internet: www.schmersal.com

We hereby certify that the hereafter described components both in their basic design and construction conform to the applicable European Directives.

**Name of the component:** E, N and R program

**Type:** See ordering code

**Description of the component:** Command and signalling devices optionally as illuminated signalling devices, Push, illuminated, palm buttons and switches, Selector switches and buttons, key selector switches and key selector buttons in conjunction with contact element EF and RF or light elements and voltage senders EL\* and RL\*

**Relevant Directives:**  
Low Voltage Directive 2014/35/EU  
EMC-Directive \* 2014/30/EU  
RoHS-Directive 2011/65/EU

**Applied standards:** DIN EN 60947-5-1:2010

**Place and date of issue:** Wuppertal, May 9, 2017

ENR-Programm-D-EN

Authorised signature  
**Philip Schmersal**  
Managing Director



The currently valid declaration of conformity can be downloaded from the internet at [www.schmersal.net](http://www.schmersal.net).



**K. A. Schmersal GmbH & Co. KG**  
Möddinghofe 30, D - 42279 Wuppertal  
Postfach 24 02 63, D - 42232 Wuppertal

Phone: +49 - (0)2 02 - 64 74 - 0  
Telefax: +49 - (0)2 02 - 64 74 - 1 00  
E-Mail: [info@schmersal.com](mailto:info@schmersal.com)  
Internet: <http://www.schmersal.com>