

OVERLAPPING TWO-DOOR WALL-MOUNT ENCLOSURES

Application

Designed to house electrical and electronic controls, instruments and components. Provides protection from dust, oil and water. For outdoor application a drip shield and drain holes are required. For installation information, consult our Installation Manual at www.saginawcontrol.com.

Construction

- 0.075" carbon steel.
- Seams continuously welded and ground smooth, no holes or knockouts.
- Flange trough collar around all sides of door opening.
- Gasketed overlapping doors eliminate need for center post.
- Black zinc die cast keylocking/padlocking handle.
- 3-point latching mechanism.
- Latch rods have ramp shoes for easier door closing.
- Concealed hinges.
- Removable and interchangeable doors.
- Removable print pocket provided on door with 3-point latch.
- Pour in place oil and water resistant gasket
- Collar studs for mounting optional sub-panel.
- Ground stud on door and body.
- Mounting hardware, sealing washers and hole plugs included.

Finish

ANSI-61 gray powder coated inside and out. Optional sub-panels powder coated white.

Options

Optional mounting foot kit available (SCE-ELMFK6).

IS3 Industry Standards

NEMA Type 3R, 12 & Type 13
UL Listed Type 3R & 12
CSA Type 3R & 12
IEC 60529 IP55

***To maintain Type 3R listing, Drainage is required. Install equally rated drainage device or drill a 1/8 to 1/4 inch hole in the bottom center of the enclosure, approximately 1 inch from the right, and 1 inch from the left for drainage, use listed rain-tight or wet location hubs. Drip shield over the door is recommended for all outdoor applications.

Enclosure Product Code A4

Sub-Panel (P3)

Catalog No.	Height (A)	Width (B)	Depth (C)	Industry Standard	Catalog No.	Panel Height (D)	Panel Width (E)
SCE-244208WFLP	24.00	42.00	8.00	IS3	SCE-42P24	39.00	21.00
SCE-244212WFLP	24.00	42.00	12.00	IS3	SCE-42P24	39.00	21.00
SCE-244808WFLP	24.00	48.00	8.00	IS3	SCE-48P24	45.00	21.00
SCE-244812WFLP	24.00	48.00	12.00	IS3	SCE-48P24	45.00	21.00
SCE-304210WFLP	30.00	42.00	10.00	IS3	SCE-42P30	39.00	27.00
SCE-304810WFLP	30.00	48.00	10.00	IS3	SCE-48P30	45.00	27.00
SCE-306010WFLP	30.00	60.00	10.00	IS3	SCE-60P30	57.00	27.00
SCE-306012WFLP	30.00	60.00	12.00	IS3	SCE-60P30	57.00	27.00
SCE-364212WFLP	36.00	42.00	12.00	IS3	SCE-42P36	39.00	33.00
SCE-364216WFLP	36.00	42.00	16.00	IS3	SCE-42P36	39.00	33.00
SCE-364810WFLP	36.00	48.00	10.00	IS3	SCE-48P36	45.00	33.00
SCE-364812WFLP	36.00	48.00	12.00	IS3	SCE-48P36	45.00	33.00
SCE-364816WFLP	36.00	48.00	16.00	IS3	SCE-48P36	45.00	33.00
SCE-366012WFLP	36.00	60.00	12.00	IS3	SCE-60P36	57.00	33.00
SCE-366016WFLP	36.00	60.00	16.00	IS3	SCE-60P36	57.00	33.00
SCE-424212WFLP	42.00	42.00	12.00	IS3	SCE-42P42	39.00	39.00
SCE-424216WFLP	42.00	42.00	16.00	IS3	SCE-42P42	39.00	39.00
SCE-424812WFLP	42.00	48.00	12.00	IS3	SCE-48P42	45.00	39.00
SCE-424816WFLP	42.00	48.00	16.00	IS3	SCE-48P42	45.00	39.00
SCE-426012WFALP	42.00	60.00	12.00	IS3	SCE-60BFP42	56.00	38.00
SCE-426016WFALP	42.00	60.00	16.00	IS3	SCE-60BFP42	56.00	38.00
SCE-484812WFLP	48.00	48.00	12.00	IS3	SCE-48P48	44.00	44.00
SCE-484816WFLP	48.00	48.00	16.00	IS3	SCE-48P48	44.00	44.00



OVERLAPPING TWO-DOOR WALL-MOUNT ENCLOSURES TECHNICAL DATA

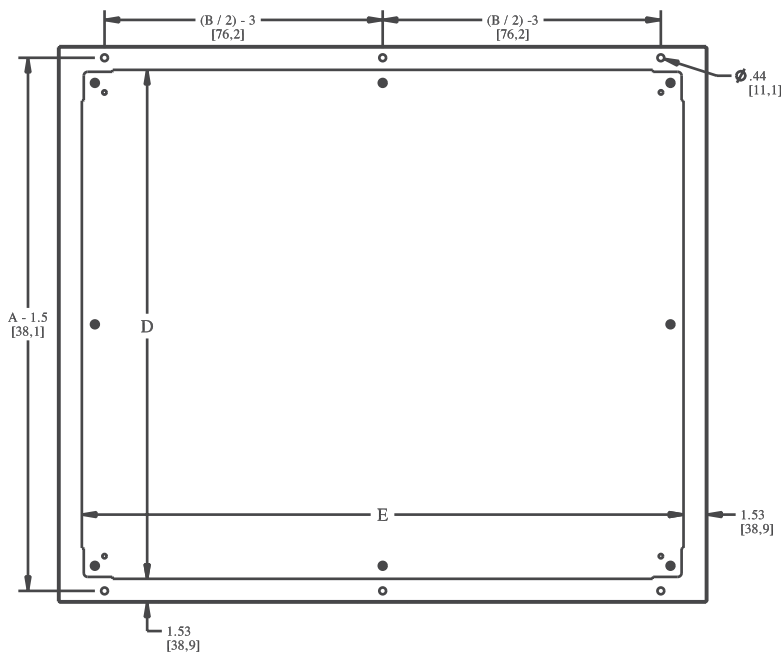
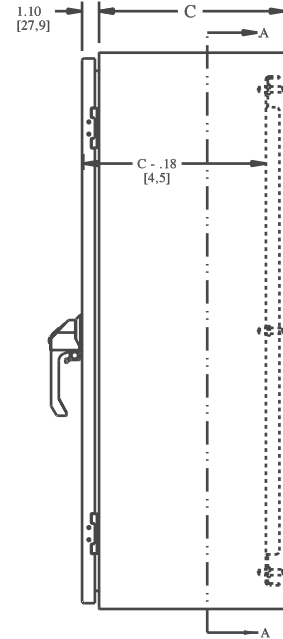
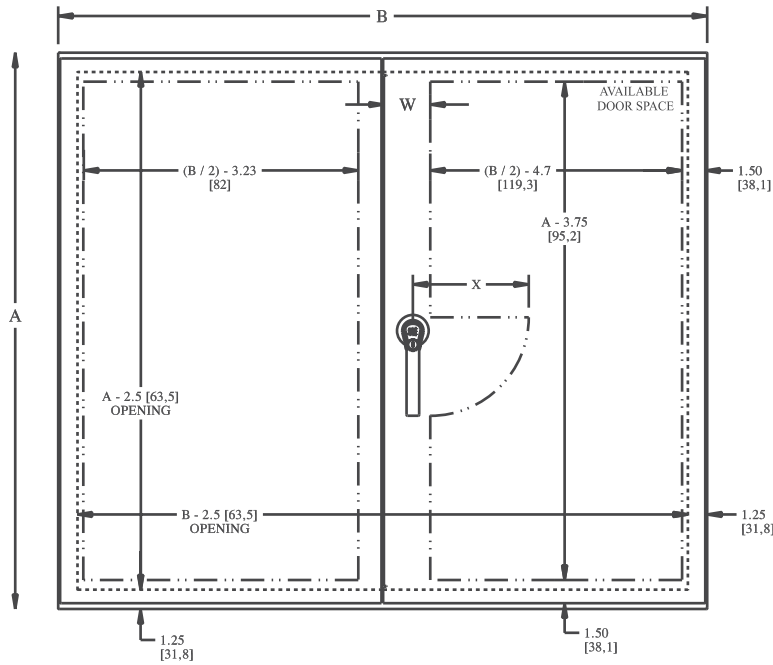

SECTION A-A

HANDLE NOTES:

Enclosures ≤ 42.00 [1067] in height
X = 5.50 [140] and uses 5.00 [127]
key-locking/padlocking handle.

Enclosures > 42.00 [1067] in height
X = 6.75 [171] and uses 7.00 [178]
key-locking/padlocking handle

W = 3.63 [92,2] > 24 inch height enclosure
W = 3.00 [76,2] 24 inch height enclosure