

Operating Manual

Attachment and installation cooling units
DTS and DTI Series 6201C / 6301C
Multi-Controller (MC) – 230 V

Version 1.0, May 2017



Preface

The skills and information provided in the ORIGINAL OPERATING MANUAL are required for assembly and safe operation of Pfannenberg cooling units.

The information is presented in a brief, clearly arranged format. The chapters are numbered throughout. If you have the operating manual in digital format, the links are **interactive**.

Various unit types are documented in this operating manual.

Pfannenberg cooling units are subject to continuous improvement. Please understand that we must reserve the right to changes in design, equipment and technology. For this reason, no claims to specific features of the unit can be derived from the content of this operating manual.

☒ A film on the DTI cooling units can be viewed [HERE](#).

Safety instructions and markings



Identifies an exceptionally dangerous situation. Severe, irreversible injuries or death will occur if this notice is not observed.



Identifies an exceptionally dangerous situation in connection with electrical voltage. Severe, irreversible injuries or death will occur if this notice is not observed.



Identifies an exceptionally dangerous situation. Severe, irreversible or deadly injuries could occur if this notice is not observed.



Identifies a dangerous situation. Minor or moderate injuries could occur if this notice is not observed.

☒ Before notices and explanations.

* Legend notice

⇒ *Placed before results of actions.*

Table of contents

1	Intended use	5
1.1	General overview	5
1.2	Permissible usage conditions	5
1.3	Duty of the operator	5
2	Unit description	6
2.1	Description of use	6
2.2	Scope of delivery	6
2.3	Order options	6
2.4	Functional description	7
2.4.1	Air flow functional principle	7
2.4.2	Controller	8
2.4.3	Refrigerant circuit functional principle	9
2.4.4	Safety concept	9
2.4.5	Accumulation of condensate	10
2.4.6	Energy-saving mode	10
2.4.7	Multimaster function	11
2.5	Type plate	12
2.6	Technical data	13
2.6.1	Refrigeration data	13
2.6.1	Electrical data	13
2.6.2	Dimensions	13
2.6.3	Other unit data	13
3	Assembly and initial commissioning	14
3.1	Transport	14
3.2	Storage	14
3.3	Unpacking	15
3.4	Assembly	15
3.4.1	General assembly requirements	16
3.4.2	Mounting M8 jack rings	16
3.4.3	DTS cooling unit assembly (side attachment)	17
3.4.4	DTI cooling unit assembly (installation)	19
3.5	Electrical connection	21
3.5.1	Multi-Controller (MC) electrical circuit diagram	21
3.5.2	Multimaster connection	21
3.5.3	Door contact switch	22
3.5.4	Mains supply connection	23
3.5.5	Adapting the upstream fuse /transformer options	25
3.5.6	Collective fault signal	25

4	Operation	26
4.1	General functions.....	26
4.2	Multi-Controller operation	27
4.3	Carrying out menu settings.....	27
4.4	Operation of the cooling unit.....	29
4.5	Service interface	30
4.6	Error messages.....	31
4.7	LCD error messages.....	34
5	Service and Maintenance	35
5.1.	General cleaning.....	35
5.2	Cleaning the cooling unit - Unit cover removal.....	36
5.3	Cooling unit and filter mat cleaning tasks	37
5.4	Maintenance	38
5.5	Maintenance checklist template.....	39
5.6	Decommissioning	40
6	Troubleshooting.....	41
7	Spare part orders / accessory orders	42
8	Terms of warranty	42

1 Intended use

1.1 General overview

The Pfannenberg attachment and installation cooling units of the DTS and DTI series are stationary cooling units for the dissipation of heat from switch cabinets. They are available in two versions:

- The DTI cooling units are partially recessed in the side or installed in the door.
- The DTS cooling units are mounted on the side or on the door.

The cooling units have different cooling outputs. For exact watt specifications, see [Technical data](#).

The cooling units have cut-out compatibility with air/air heat exchangers and air/water heat exchangers. Use of aluminum filters, fleece filters and fluted filters is possible with an additional adapter.

The cooling units are available with different controllers. Cooling units are available with a standard controller (SC) or a Multi-Controller (MC). These controllers are regulating units for the adjustment of refrigeration functions and operating data. They also enable readouts of system messages and diagnostic data. The Multi-Controller (MC) is also equipped with a Multimaster function and energy saving mode.

☒ For detailed specifications for the controller, see [Technical data](#), [Electrical connection](#) and [System information](#).

All Pfannenberg cooling units are ROHS-compliant and free from:

- Silicone connections
- PCT, asbestos, formaldehyde, cadmium
- Moisture-impairing substances

1.2 Permissible usage conditions

- The permissible ambient air temperature range of DTI/DTS cooling units is +15°C (+59°F) to +55°C (+131°F).
- The permissible storage temperature of DTI/DTS cooling units must not exceed +70 °C (+158°F).

1.3 Duty of the operator

The operator must ensure that the cooling units are used exclusively as intended and dangers of all types to the life and limb of users or third parties are avoided. In addition, accident prevention regulations and recognized safety rules are to be observed.

The operator must ensure that all users have read and understood this operating manual.

Non-observance of this operating manual will void the warranty. The same applies if improper work has been carried out on the unit by the customer and/or third parties without the approval of the manufacturer.

2 Unit description

2.1 Description of use

Pfannenberg DTS and DTI series attachment and installation cooling units are designed to dissipate heat from switch cabinets. Sensitive components in the switch cabinet are protected. Condensate arising during the cooling is removed by an integrated system.

☒ The cooling units operate with very low flammable refrigerant that is not harmful to the ozone layer.

2.2 Scope of delivery

The shipment consists of the following contents:

- DTI/DTS cooling unit
- Cooling unit quick guide
- Accessory kit: Appropriate seal, fastening material, electrical plug connector, etc. for the specific unit type
- Special accessories, if applicable

2.3 Order options



WARNING

Spare parts from third-party manufacturers can damage the unit

- Only original parts are subject to the manufacturer's quality control.
- Only use specially harmonized manufacturer parts for safe and reliable operation.

☒ For Pfannenberg spare part numbers, see [Spare part orders](#).

There is an optional expansion with a filter adapter for various filter mats (fleece filters, fluted filters and metal filters).

☒ For Pfannenberg part numbers for accessory orders, see Ordering of [accessory parts](#).



WARNING

Danger due to impermissible use of units

Inappropriate use of the units can cause severe accidents.

- Cooling units must only be used in stationary operation.

The DTI/DTS cooling units are only approved for stationary operation. As cooling units with protection rating IP 54, the cooling units are essentially dust-protected. Limitation: Dust can still penetrate after continuous exposure. The cooling units are resistant to spray water, but not a constant water jet.

2.4 Functional description

2.4.1 Air flow functional principle

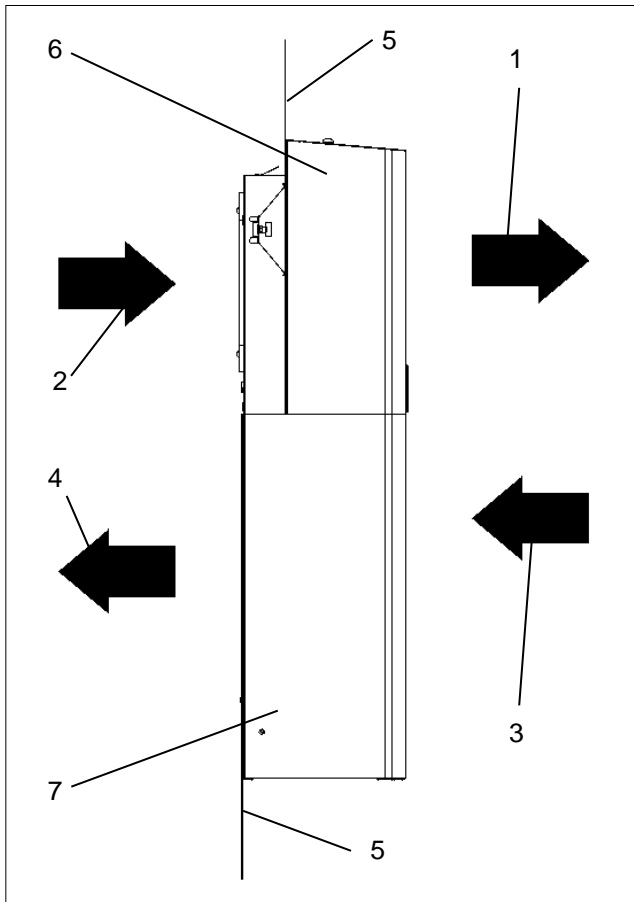

Figure 1 - DTS/DTI switch cabinet air flow principle front view

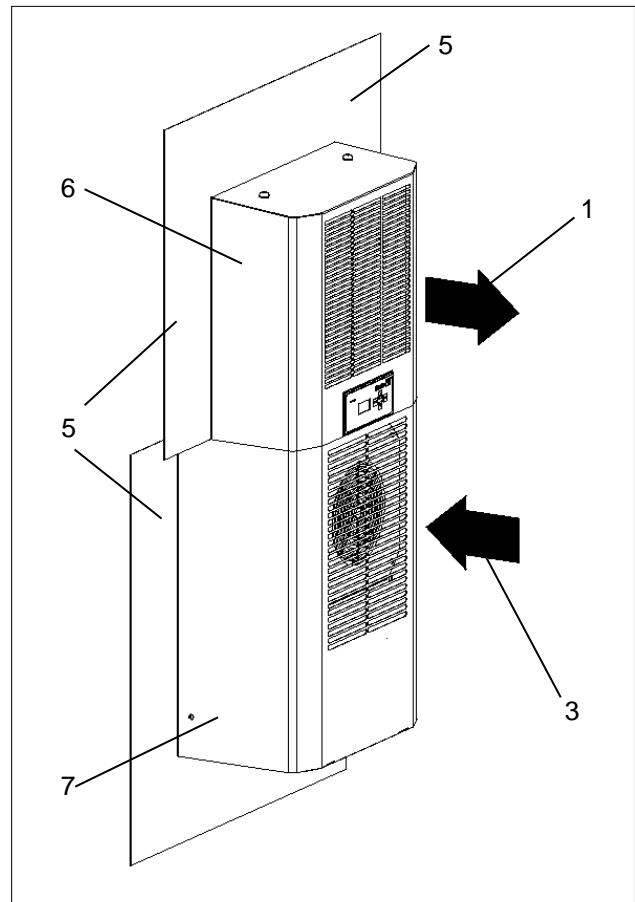

Figure 2 - DTS/DTI switch cabinet air flow principle side view

Item	Designation	Item	Designation
1	Ambient air outlet	2	Warm air inlet
3	Ambient air inlet	4	Cold air outlet
5	Switch cabinet	6	DTI unit cover
7	DTS unit cover		

☒ The upper part of the figures – Air flow principle front view – shows the DTI cooling unit and the lower part shows a DTS cooling unit.

CAUTION

Danger due to the release of very warm air

The air outlet can become very warm depending on the ambient temperature.

- Keep body parts away from the air outlet.

☒ For the ambient temperature and air outlet ratio, see [Technical data](#).

2.4.2 Controller

Controllers are regulating units for the adjustment of refrigeration functions and operating data. They enable readouts of system messages and diagnostic data. The controllers have a service interface which enables various configurations. There is also a connection for collective fault indications.

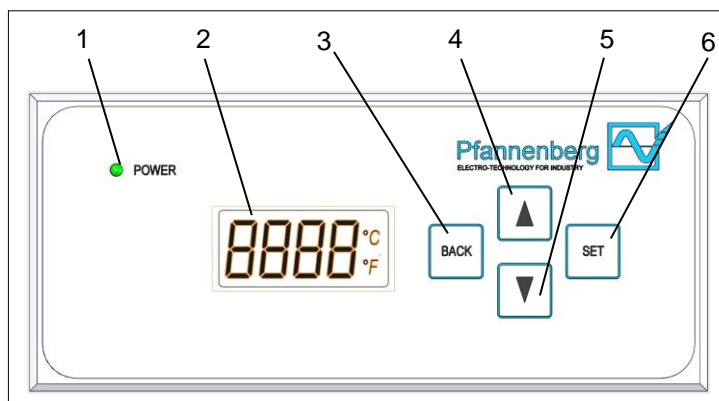

Figure 3 - Multi-Controller (MC) control panel

Item	Control panel	Function
1	Green LED light	- Displays the operating mode: Permanently illuminated = fault-free / blinking = operational fault
2	LCD (4-digit)	- Displays system information: Temperature measuring unit, energy function, operating mode, system data, error number and menu settings / menu items / menu level.
3	BACK button	- Activation of menu settings. - Jump back to the next higher menu level.
4	SCROLL UP button	- SCROLL UP through the menu items or display elements in the current menu level
5	SCROLL DOWN button	- SCROLL DOWN through the menu items or display elements in the current menu level
6	SET button	- Selection of the current menu item. - Jump to the next lower menu level.

Cooling units with a multi-controller (MC) have a control panel with a green LED light (1) and an LCD (2). They are located on the unit cover. Permanent illumination of the green LED light (1) while the mains voltage is connected indicates fault-free operation. System information is displayed in the LCD. The following system information can be displayed:

LCD	System information
	Display – Temperature (°C/°F) of the regulating sensor in normal operating status.
	Display – Stop mode execution. Door is open. Alternating display with temperature and stop mode, with fault Er00. Display: StoP →Er00→Temperature.
	Display – Energy function execution, activated in energy saving mode Alternating display with temperature display (°C/°F).
	Display – Error number when a fault occurs. In case of a fault, error number (Er01-Er15) is displayed alternating with temperature (°C/°F). Exception, fault ER00: Display StoP →Er00→Temperature.

In case of an operating fault or a malfunction, the gray LED light (1) begins to blink and the LCD (2) displays error numbers alternating with the temperature. For details, see [Error messages](#) .

2.4.3 Refrigerant circuit functional principle

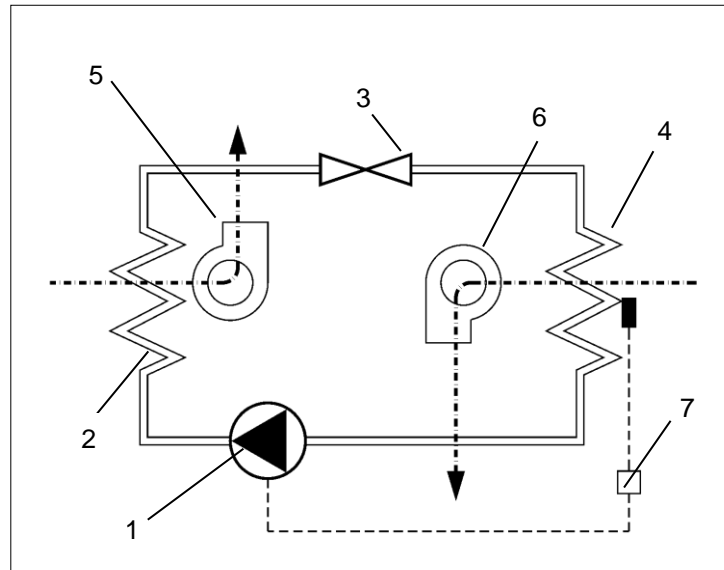

Figure 4 - Refrigerant circuit

Item	Designation	Item	Designation
1	Compressor	2	Condenser
3	Expansion valve	4	Evaporator
5	Condenser fan (external)	6	Evaporator fan (internal)
7	Electronic control with temperature sensor		

The cooling units are comprised of various components; see the figure Refrigerant circuit.

- The compressor (1) compresses the refrigerant under high pressure. The temperature increases.
- This heat is released to the ambient air in the condenser (2). The refrigerant liquefies.
- The condenser fan (5) draws room air through the condenser (2) and releases it to the environment.
- A pressure drop occurs when the refrigerant passes through the expansion valve (3).
- Inside the evaporator (4), the refrigerant absorbs heat from the air inside the switch cabinet and evaporates. The air inside the switch cabinet is cooled and dehumidified.
- The evaporator fan (internal) (6) draws the air inside the switch cabinet through the evaporator (4) and releases the cooled air back to the switch cabinet.

- ☒ The cooling units are controlled with a temperature sensor (7). It detects the air temperature inside the switch cabinet.

2.4.4 Safety concept



WARNING

Danger due to modified safety equipment

Non-functioning or defective safety equipment can cause severe accidents.

- Any changes to the unit, particularly the safety equipment, are prohibited.
- In case of defective safety equipment, shut down the unit and decommission it immediately.

- Cooling units have a pressure switch tested in accordance with EN 12263. It reacts to a pressure increase in the refrigerant circuit by shutting off automatically.
- Fans and compressors are protected from overloading and overheating: e.g. the compressor is protected against overlocking.

Additional protective functions (only cooling units with anti-freeze option):

- If there is a risk of ice formation, switch off the compressor and the fans.
- This shut-off function is not withdrawn until a system restart.

2.4.5 Accumulation of condensate

NOTE

Condensate flowing back into the switch cabinet can damage the electronic components

Internal temperatures below the dewpoint or damaged switch cabinet seals cause excessive accumulation of condensate.

- Regular inspection of the seals assures protection against heavy condensate accumulation.
- Installation of a door contact switch reduces the accumulation of condensate when the switch cabinet is open.

If the evaporator cools down, condensate can accumulate. In order to prevent damage to the switch cabinet and the cooling units, the condensate is removed. The integrated condensate evaporator releases the condensate to the environment. For safety reasons, there is a drain port with drain hose on the condensate evaporator.

☒ Accumulating condensate is collected by a condensate collecting bottle. It is available as an accessory.

☒ In case of questions about the cooling units or accessories and spare part orders, always specify the serial number; see [Spare part orders](#).

2.4.6 Energy-saving mode

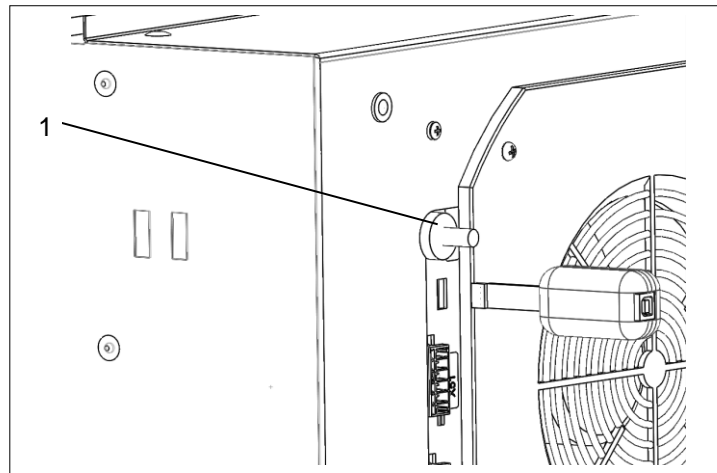

Figure 5 – TS2- Temperature sensor

Cooling units with Multi-Controller (MC) are equipped with energy-saving mode. Therefore, it has a second TS2 temperature sensor (1), which is installed externally on the cooling unit. The TS2 temperature sensor (1) monitors the switch cabinet interior temperature.

- In the condition as supplied, energy-saving mode is activated when cooling operation is not activated for 30 minutes. The LCD then displays energy function "EN", [see system information](#)
- If the switch cabinet interior temperature increases above the adjusted temperature setpoint during active operation, a cooling command is sent and energy saving mode is interrupted.
- Cooling mode remains active until the temperature setpoint, minus hysteresis, has been reached. Energy-saving mode always activates 30 minutes after the temperature setpoint is reached.
- If the temperature setpoint is undercut by the external TS2 temperature sensor (1) in energy-saving mode, the evaporator fan (internal) switches off. The temperature setpoint is measured minus hysteresis.
- If the external TS2 temperature sensor (1) detects a temperature that exceeds the temperature setpoint, the evaporator fan (internal) switches on. The value of the temperature setpoint is measured plus hysteresis.
- If no fault occurs, the fault indication output is closed in energy saving mode.

2.5 Type plate



WARNING

Danger due to damage of units

Disregarding type plate specifications can result in severe accidents.

➤ Always observe the specifications on the type plate when installing and maintaining the units.

- ☒ The type plate is located on the rear side of the cooling unit housing.
- ☒ The figure shows the standard version for EU Member States. The type plate version may differ in other countries.

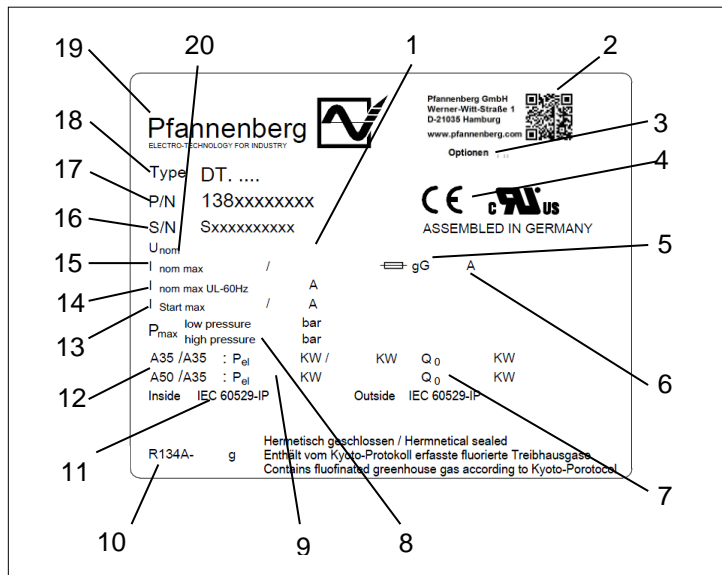

Figure 7 - Type plate for EU Member States

Item	Designation	Item	Designation
1	Frequency	2	QR code
3	Options	4	CE mark
5	Protection type	6	Protection
7	Cooling capacity	8	Coolant pressure
9	Power rating	10	Coolant
11	Protection type	12	Exterior / interior ambient conditions
13	Start-up current	14	Nominal current (UL 60 HZ)
15	Nominal current	16	Serial number
17	Part number	18	Unit type
19	Manufacturer logo	20	Rated operating voltage

2.6 Technical data

2.6.1 Refrigeration data

Designation		Model DTI/DTS 6201C	Model DTI/DTS 6301C
Cooling capacity A35 / A35 * / **	Q ₀	1000 W	1500 W
Cooling capacity A50 / A35 * / **	Q ₀	590 W	850 W
Refrigerant type *		R 134a	
Refrigerant quantity *		500 g	
Temperature setpoint (factory setting)		+35°C (+95°F)	
Fault indication: Switch cabinet interior temperature (factory setting)		> +50°C (+122°F)	
Ambient air temperature		+15°C (+59°F) bis +55°C (+131°F)	
Switch cabinet interior temperature		+25°C (+77°F) bis +45°C (+113°F)	
Air volume flow, exterior circuit		885 m ³ /h	
Air volume flow, interior circuit		885 m ³ /h	
Condensate separation		Condensate evaporator	

2.6.1 Electrical data

Designation		Model DTI/DTS 6201C		Model DTI/DTS 6301C	
Rated operating voltage * / ****		230 V			
Rated frequency *		50 / 60 Hz			
Functional range		DIN IEC 60038			
		50 Hz	60 Hz	50 Hz	60 Hz
Power consumption *	P _{el} A35/A35	445 W	560 W	705 W	820 W
Rated current*	I _{nom max}	2,04 A	2,9 A	5 A	5,2 A
Starting current*	I _{Start max}	9,1 A		16 A	

2.6.2 Dimensions

Designation	Model DTI/DTS 6201C	Model DTI/DTS 6301C
Height DTS	968 mm	
Height DTI	962 mm	
Width	410 mm	
Depth with cover (standard)	253 mm	
Installation depth DTI	60 mm	
Weight	DTI: 40 kg / DTS: 41 kg	DTI: 44 kg / DTS: 45 kg
Installation attitude	Vertical	
Unit construction	Standard: Steel	

2.6.3 Other unit data

Designation	Model DTI/DTS 6201C	Model DTI/DTS 6301C
Anti-corrosion protection	Standard: Galvanized, electrostatic powder-coated (200°C) Variant: Stainless steel cover	
Protection type	When used as intended: IP 54 against the switch cabinet (EN 60529). IP 34 against the environment (EN 60529).	

* Data on the type plate.

*** Max. rated current UL at 60 Hz.

** Use of optional filter mats reduces the cooling capacity.

**** With a change to the rated operating voltage, adapt the upstream fuse; see [Adapting the upstream fuse](#).

3 Assembly and initial commissioning

3.1 Transport



WARNING

Danger due to uncontrolled movements

Improper securing of the unit can result in severe accidents.

- Loading must only be carried out by trained, qualified personnel.
- Lash the unit correctly for transport on a truck or trailer.
- Only use lashing straps with an adequate rated strength.
- Use slip-resistant materials for securing, e.g. anti-slip mats.
- When loading by crane, do not walk or stand under the raised units.

NOTE

Danger of material damage during transport and setting down of the units.

- Improper device securing or uncontrolled movements can cause damage.
- Exercise maximum caution during movement and transport of the units.
- Always transport the unit in the position of use.

Always transport the cooling units using the packaging provided by the factory. It comprises an outer carton, base plate and padding at the top and base.

Transporting cooling units

Requirements

- Cooling units must be in the packaging provided by the factory.

Required tools and material

- Lashing straps, loading crane, if applicable

Procedure

- Secure correctly for transport with lashing straps. Always transport in the position of use.
- Always raise cooling units by the housing.
- Always raise cooling units slowly and evenly and set down safely.

⇒ *The cooling unit was transported and loaded correctly.*

- ☒ The cooling unit can also be loaded using M8 jack rings; for this purpose, the M8 jack rings are first screwed into the cooling unit; see Mounting **M8 jack ring**.

3.2 Storage

- Do not expose the cooling unit to temperatures above +70 °C during storage.
- Always store the cooling unit in the position of use.
- ☒ The warranty will no longer apply if these instructions are not observed.

3.3 Unpacking

WARNING

Danger of accidents due to the heavy weight of the units

Uncontrolled movements of the units during assembly can cause accidents.

- Use suitable lifting equipment and secure units to prevent accidents.
- Also secure assembled components.

CAUTION

Danger of injury due to sharp edges

- For manufacturing reasons, the metal edges of the unit may have burrs.
 - Wear gloves during service and assembly work.
-
- Perform a visual inspection for transport damage when unpacking the cooling units. Take note of any loose parts, dents, scratches, visible loss of oil etc.
 - Inspect and secure the packaging material for any loose functional parts before disposal.
- ☒ Report any damages to the freight carrier immediately. Observe the "Terms for Cases of Damage".
- ☒ Precise information about defects, including possible photos must be provided for the handling of warranty claims. Always specify the type designation and serial number.
- ☒ The "General Terms for Deliveries and Services" of ZVEI (Zentralverband der Elektrotechnischen Industrie; Central Association of the Electrical Engineering and Electronics Industry in Germany) according to the latest revision apply.

3.4 Assembly

DANGER

Life-threatening danger due to electric shock

Live units and exposed connection cables can generate an electric shock and cause severe accidents.

- Work on electrical connections must be carried out exclusively by trained, qualified electricians.
- Before assembly, de-energize all supply lines to the separate fuse or a main switch, disconnect the system and secure to prevent re-connection.
- Test to ensure the absence of voltage on the unit.

CAUTION

Danger of crushing during assembly of the unit

There is a danger of crushing between the switch cabinet and frame of the unit during assembly.

- Keep body parts out of the space between the frame and unit cut-out.
- Work carefully and wear gloves.

NOTE

Switch cabinet installation hazard due to assembly chips

When making the cooling unit cut-outs, assembly chips can fall into the switch cabinet.

- When assembling the switch cabinet, protect against contaminants and use protective covers.

3.4.1 General assembly requirements

The following general requirements must be followed for safe and reliable operation of the cooling units:

- Select an assembly location for the switch cabinet which will guarantee adequate ventilation of the cooling unit. A minimum clearance of 200 mm between units and the nearest wall must be observed.
- Installed components in the switch cabinet must not impede air circulation.
- Secure the switch cabinet against tipping.
- Ensure that provided hinges can support the additional weight of the cooling unit.
- The cooling unit can be assembled with and without an external unit cover.
- Protect the installation location from heavy contamination with covers.

3.4.2 Mounting M8 jack rings



WARNING

Danger of accidents due to unapproved crane transport

Movement of switch cabinets with integrated cooling units can result in accidents.

- Only lifting by M8 jack rings is permitted for the cooling unit.
- Ensure that jack rings and unit threads are not damaged or deformed.
- Only use jack rings with an adequate thread length and ensure that they are securely seated.

The cooling units have threads for M8 jack ring installation. M8 jack rings can be installed in cooling units for crane transport.

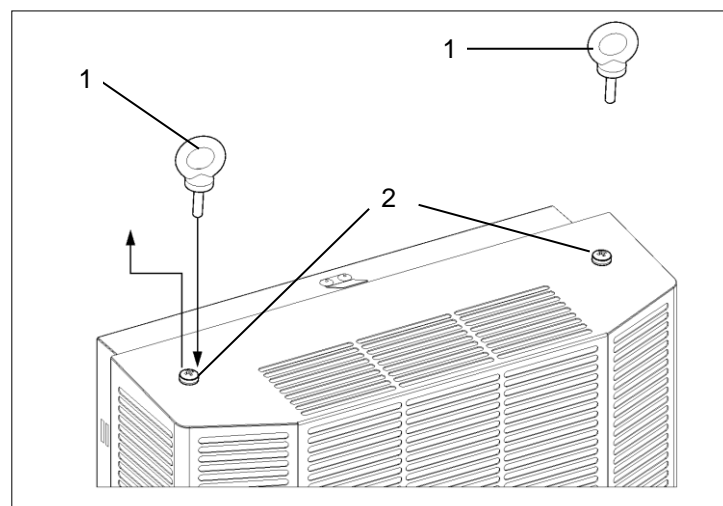

Figure 8 - DTI/DTS cooling unit M8 jack rings

Item	Designation	Item	Designation
1	DTS cooling unit M8 jack rings	2	Unit cover screws

Requirements

- The factory-provided packaging has been removed from the cooling units.
- Observe the minimum screw depth of the M8 jack rings.
- M8 jack rings and cooling unit threads must be free from damage (corrosion and deformation).
- The unit cover screws (2) have been removed.

Procedure

- Screw in the two M8 jack rings (1) completely with the appropriate thread depth.
- Check to ensure the proper seating of the M8 jack rings in the cooling unit.

⇒ The M8 jack rings are screwed in the cooling unit and the unit can be moved.

3.4.3 DTS cooling unit assembly (side attachment)

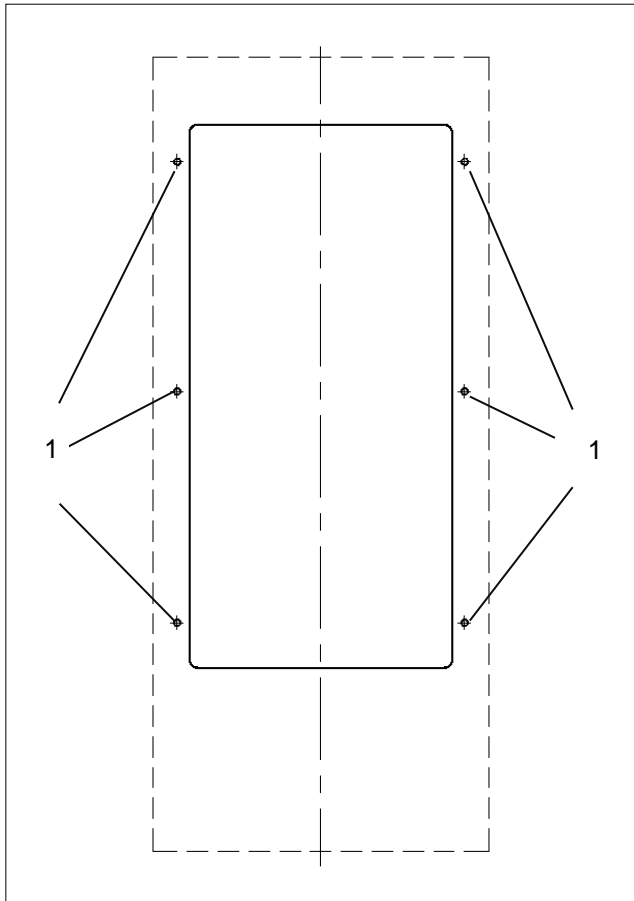

Figure 9 - Switch cabinet exterior view
Holes for DTS cooling unit

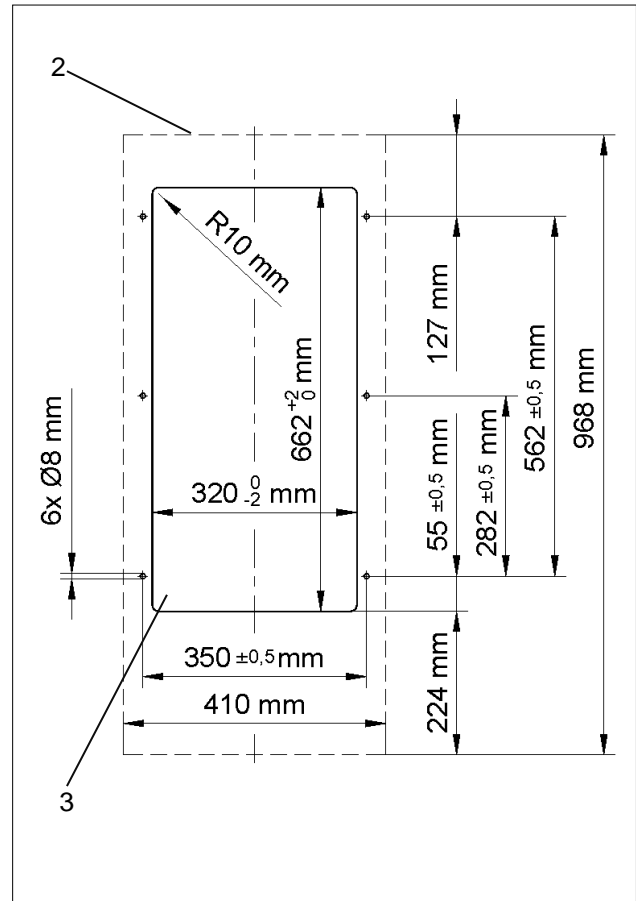

Figure 10 - Switch cabinet exterior view
Cut-out for DTS cooling unit

Item	Designation	Item	Designation
1	Holes	2	Device contour
3	Cut-out		

Make cut-out for the DTS cooling unit

Requirements

- All general requirements have been fulfilled; see [General assembly requirements](#)
- The unit is de-energized.

Required tools and material

- Saw
- Use a switch cabinet cutter, if applicable
- Protective covers

Procedure

- Use a protective cover to protect the switch cabinet from chips.
- Provide the switch cabinet with cut-out (3) and holes (1). For the prescribed dimensions, refer to the figure exterior view of the switch cabinet.
- Deburr the cut edges.
- Remove chips and assembly waste from the switch cabinet.

⇒ *Cut-out and holes have been made.*

Install profile seal on the DTS cooling unit (side attachment)

WARNING

Danger of accidents due to incorrectly installed seals

Leaky seals can allow moisture to penetrate and cause short-circuits.

- Install the seal so that it provides a tight seal to the switch cabinet.
- Always inspect seals during cleaning and maintenance.

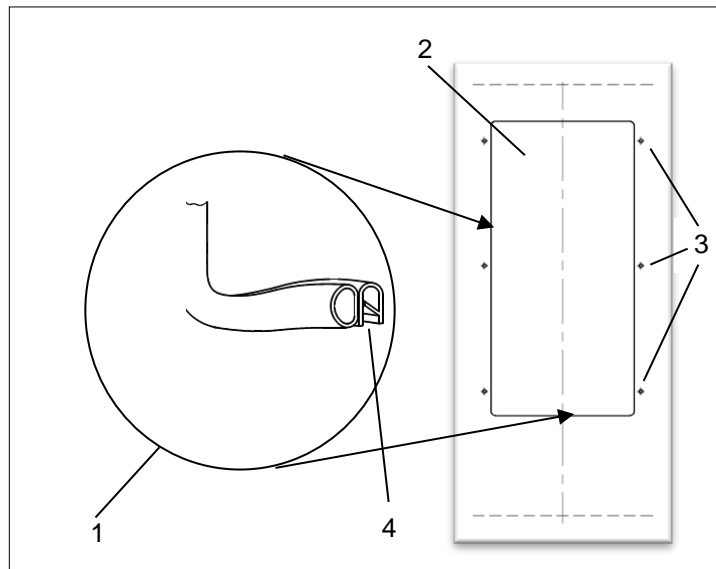

**Figure 11 – Install profile seal
DTS cooling unit (side attachment)**

Item	Designation	Item	Designation
1	Profile seal	2	Cut-out for seals
3	Switch cabinet interior fastenings	4	Profile seal slotted ends

Install profile seals and assemble

Requirements

- Cut-out for the DTS cooling unit have been made; see figure [DTS cooling unit assembly](#)_(side attachment).
- The cooling unit is de-energized.

Required tools and material

- Profile seal (1)
- Installation tool
- Accessory kit: Threaded bolts, screws, nuts, washers

Procedure

- Insert profile seals (1) on the sheet metal edge of the cut-outs (2). Fit the seals with the slotted ends (4) down.
- Screw in the two supplied threaded bolts (accessory kit) in the upper fastening points of the DTS cooling unit. Suspend the cooling unit on the switch cabinet with the threaded bolts installed from outside. Tighten the screws on the DTS cooling unit on the switch cabinet interior (3). Use the supplied screws, nuts and washers (accessory kit) to fasten the unit. Firmly tighten the screw fasteners so that the profile seal is pressed together to a thickness of 2 mm.

⇒ The DTS cooling unit is attached to the switch cabinet and ready for electrical connection; see [Electrical connection](#).

3.4.4 DTI cooling unit assembly (installation)

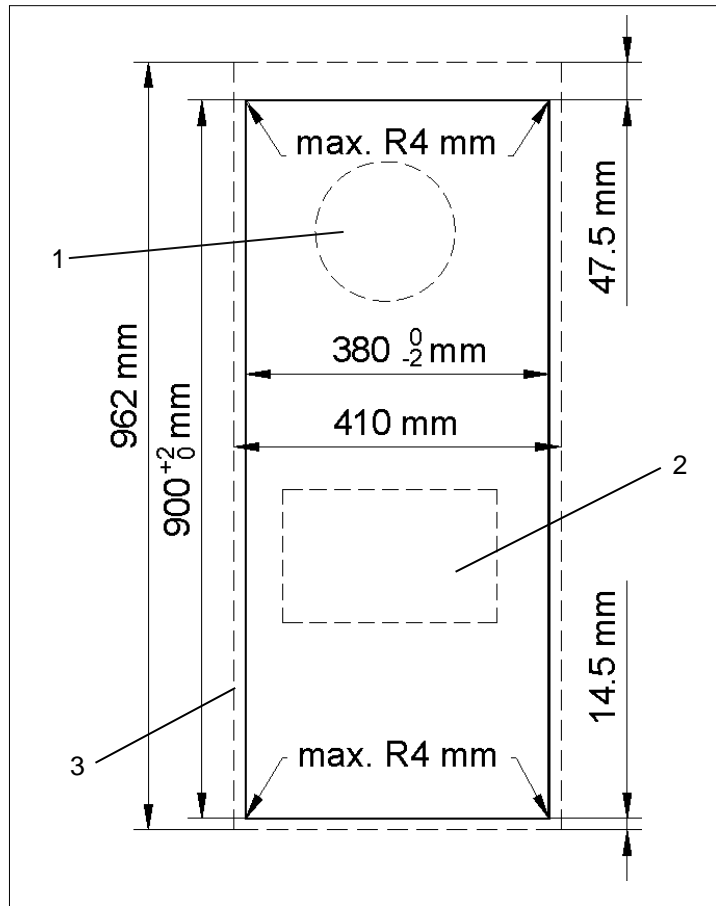

Figure 12 - Switch cabinet exterior view
DTI cooling unit cut-outs

Item	Designation	Item	Designation
1	Air inlet	2	Air outlet
3	Device contour		

Make cut-outs for the DTI cooling unit

Requirements

- All general requirements have been fulfilled; see [General assembly requirements](#)
- The unit is de-energized.

Required tools and material

- Saw
- Use a switch cabinet cutter, if applicable
- Protective covers

Procedure

- Use a protective cover to protect the switch cabinet from chips.
- Provide the switch cabinet with cut-outs. For the prescribed dimensions, refer to the figure switch cabinet exterior view.
- The four corner cut-outs can be rectangular or have a maximum R = 4 mm.
- Deburr the cut edges.
- Remove chips and assembly waste from the switch cabinet.

⇒ *Cut-outs have been made.*

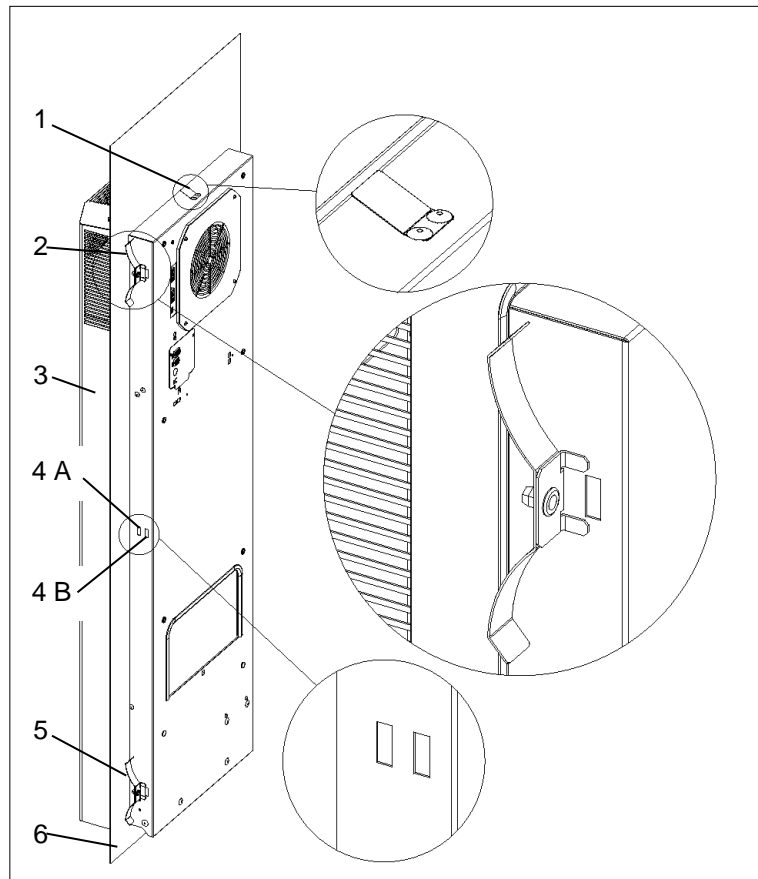
DTI cooling unit switch cabinet assembly (installation)

Figure13 – DTI cooling unit assembly

Item	Designation	Item	Designation
1	Catch spring	2	Fastening spring (top)
3	DTI cooling unit	4 A	Housing - cut-out
4 B	Housing - cut-out	5	Fastening spring (bottom)
6	Switch cabinet wall / switch cabinet door		

☒ The film for DTI cooling units with assembly instructions is available [HERE](#).

Switch cabinet assembly
Requirements

- The cut-out for the DTI cooling unit has been made; see the figure [DTI cooling unit assembly](#).
- The cooling unit is de-energized.

Required tools and material

- Assembly tool, fastening springs (2)/(5) (accessory kit)

Procedure

- Fit the cooling unit (3) in the cut-out from outside; see the figure [DTI cooling unit assembly](#).
- Push the cooling unit (3) into the switch cabinet (6) until the unit seal is applied.
- The catch spring (1) on the top side of the unit audibly engages. The cooling unit (3) is now secured from falling out.
- Engage the fastening springs (2)/(5) on the inside of the switch cabinet (6).
- Press the fastening springs in with your hand so that the retaining bracket engages in the housing cutout (4 A).
- Use the fastening springs in the rear housing cut-outs (4B) for switch cabinets with reinforcement frame.
- Mount the cooling unit (3) so that the emergency condensate drain is arranged at the bottom of the unit.

⇒ The DTI cooling unit is attached to the switch cabinet and ready for [Electrical connection](#).

3.5 Electrical connection
3.5.1 Multi-Controller (MC) electrical circuit diagram



Life-threatening danger due to electric shock

Live units and exposed connection cables can generate an electric shock and cause severe accidents.

- Work on electrical connections must be carried out exclusively by trained, qualified electricians.
- Ensure that the unit is voltage-free before routing all electrical connections.

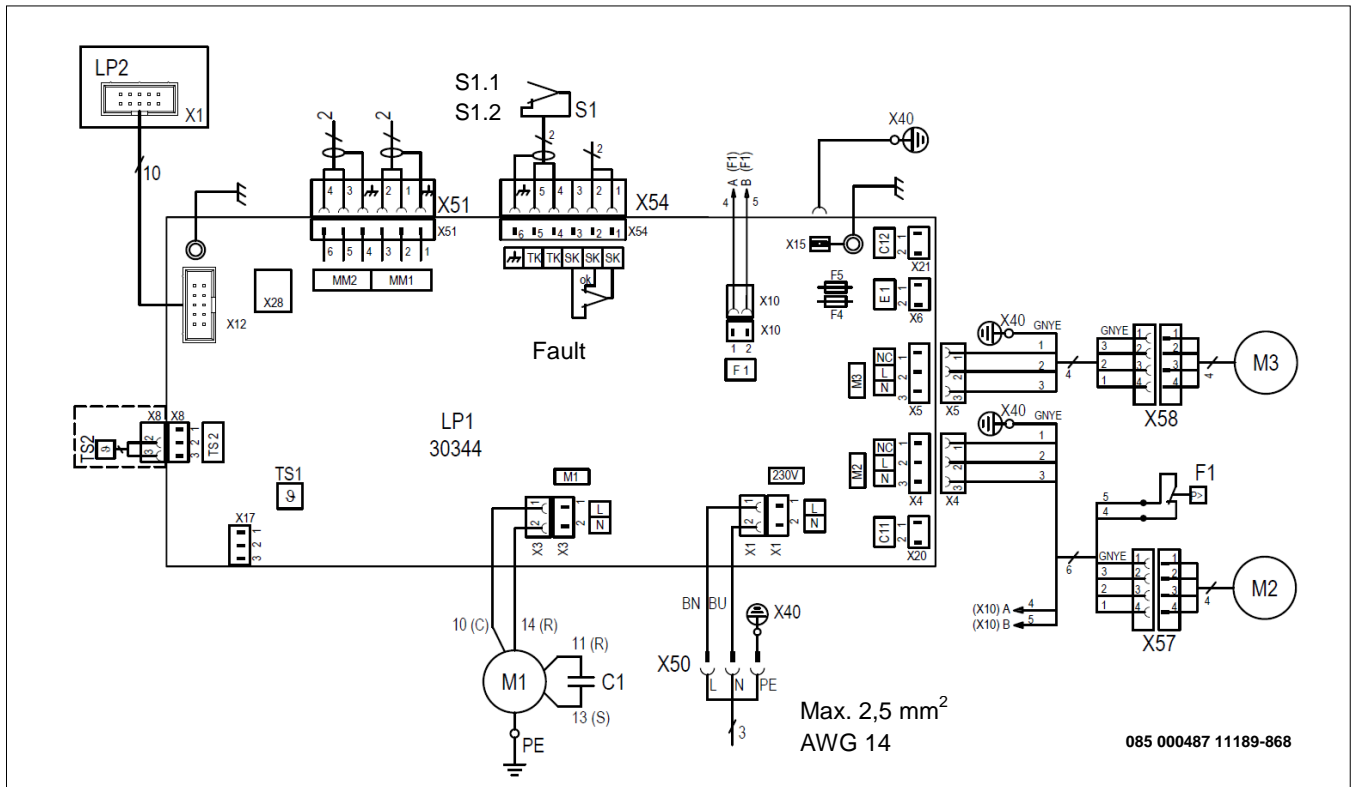

Item	Designation	Item	Designation	Item	Designation
C1	Starting capacitor	F1	High-pressure pressostat	F4-F5	Fuse
LP1	Controller	LP2	Display control unit (MC)	M1	Compressor
M2	Condenser fan (external)	M3	Evaporator fan (internal)	MM1	Multimaster/ input
MM2	Multimaster output	S1	Door contact	S1.1	Door open
S1.2	Door close	SK	Fault signal contact (1,2)	TK	Door contact/ signal (4,5)
TS1	Temperature sensor (internal)	TS2	Temperature sensor (external)	X28	Service interface (TTL)
X40	Ground terminal contact	X50	Mains terminal contact	X51	Multimaster terminal contact
X54	Door contact+ terminal contact +Fault indication		Optional	3	Power cable

3.5.2 Multimaster connection

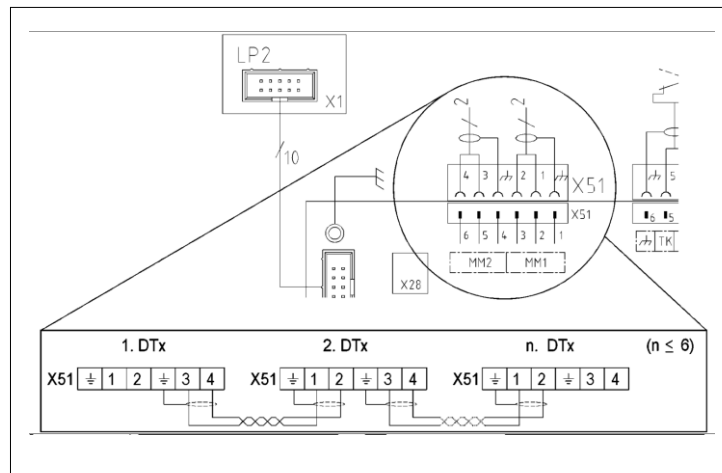

Figure 14 – Multimaster control

- The Multimaster function can control up to six connected cooling units (bus functions). The connection takes place on the input and output side via two contacts MM1 and MM2. The contacts are supplied with low voltage (<20V, 20mA) from the cooling unit.
- ☒ A shielded cable with twisted pairs is used to prevent interference.
- If shielded cables are not used, ensure that there are no sources of interference in the immediate vicinity. Sources of interference include: Supply lines and components with elevated electromagnetic radiation.

3.5.3 Door contact switch



WARNING

Danger due to connection of external voltage at the input of the door contact

External voltage can cause severe accidents.

- Connection of external voltage to the input for the door cabinet is prohibited.
- The input/door contact provides low voltage (< 20V, 20mA) for the door contact switch.

Installation of a door contact switch increases safety and prevents increased accumulation of condensate.

- ☒ If a door contact switch has not been connected, the connection contact (S1) must always be bypassed.

Door contact switch installation

Requirements

- The cooling unit is de-energized.

Procedure

- The door contact switch is connected to the S1 connection; see [Electrical connection](#) or the electrical circuit diagram in the housing cover.
- The door contact is supplied with low voltage, <20V, 20 mA, from the cooling unit.
- Connect the shielding to the terminal for functional earth on one end.
- A shielded cable with twisted pairs is used to prevent interference.
- If shielded cables are not used, ensure that there are no sources of interference in the immediate vicinity. Sources of interference include supply cables and components with increased electromagnetic radiation, including frequency converters, motor drives, etc.

⇒ The door contact switch is connected. The motors switch off when the switch cabinet is opened.

3.5.4 Mains supply connection



Potential danger due to incorrect cables

An incorrect cable cross-section will cause the cable to overheat. Scorched insulation can cause fires.

- The cable cross-section (4) matches the output required for the power consumption and is 0.5 – 2.5mm² or AWG 20 to AWG 14.

The following general requirements must be ensured for safe and reliable operation of the cooling units:

- Upstream installation of a supply-side temperature regulator is prohibited.
 - Connect the upstream fuse specified on the type plate as wiring protection; see [Type plate](#) and [Adapting the upstream fuse](#).
 - Ensure that the type plate specifications for rated values match the present values for mains voltage and mains frequency; see [Type plate](#).
 - Always connect the cooling unit to the mains by means of a separating device (switch/contacter).
- ☒ The separating device must have a contact opening of 3 mm. The separating device is installed by the customer.

Cooling unit electrical connection

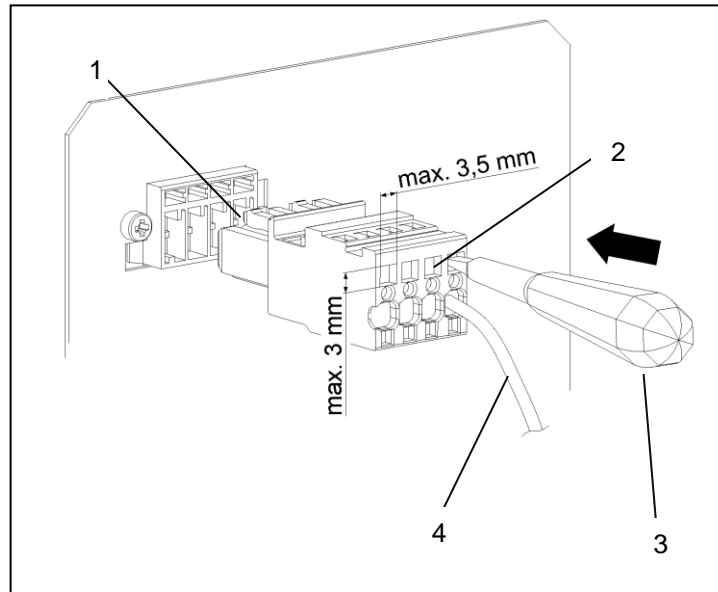

Figure 15 - Cooling unit plug connection

Item	Designation	Item	Designation
1	Connecting plug	2	Cage terminal - max. 3.5 x 3.0 mm
3	Screwdriver (slotted)	4	Cable - \varnothing 0.5 – 2.5mm ²

Requirement

- All general requirements for safe and reliable operation are assured; see [Mains supply connection](#)
- The cooling unit is de-energized.

Procedure

- Connect the cable (4) with the connecting plug (1)/(accessory kit) as specified in the electrical circuit diagram; see [Electrical connection](#).
 - For electrical connection, insert the screwdriver (3) into the cage terminal (2) and connect the cables (4) to the cooling unit with the connecting plug (1).
 - ☒ Insert the screwdriver firmly into the cage terminal (2). Never twist the screwdriver; otherwise the cage terminal (2) will be damaged.
 - Before switching on, ensure that the mains voltage matches the upstream fuse; see [Electrical connection](#).
- ⇒ *The cooling unit is connected electrically.*

3.5.5 Adapting the upstream fuse /transformer options

- ☒ Only cooling units with the rated operating voltage 400V / 460V can be optionally connected to a different mains voltage.
- ☒ Cooling units with 230V / 115V do not have any transformer options. Therefore, adaptation of the upstream fuse is not necessary.

3.5.6 Collective fault signal

- Two connections are provided for connection of the collective fault signal. They are marked with the item designation SK; see [Electrical connection](#).
- The fault signaling contact is potential-free.
- ☒ Ensure that the contact is loaded with a maximum of 230V, 1 A.

4 Operation

4.1 General functions

NOTE

Danger of damage to the cooling unit

Operation without the unit cover prevents the adequate supply of air to the condenser and limits the intended heating function.

- Only operate the cooling unit with the unit cover installed.

The Multi-Controller (MC) has a control panel with a green LED light (1). If an error occurs, the green LED light (1) blinks and various system information is displayed in the LCD (5); see [system information](#).

If assembly and installation are completed, switch on the power supply to the cooling unit.

- The cooling unit starts its operation and the LED light (1) illuminates green continuously.

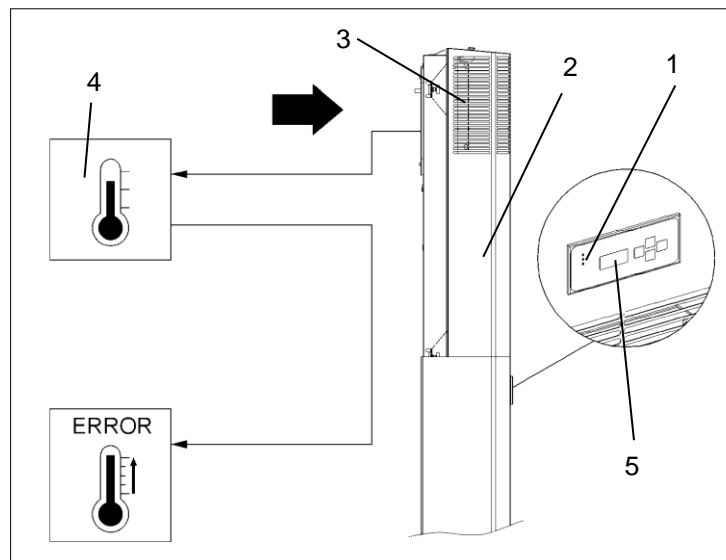

Figure 16 – Electronic control function

- After the supply voltage has been connected and the door is closed, the units run continuously.
- ⊗ Exception: Energy-saving mode and cooling units with anti-freeze option.
- ⊗ The external temperature sensor controls the energy-saving mode; see [TS2 temperature sensor](#).
- The Multimaster function can connect up to six cooling units in the bus function.
- The LCD (5) displays the current operating statuses; see [System information](#).
- The cooling unit (2) is equipped with an electronic control unit. An internal temperature sensor (4) detects the temperature of the air sucked in from the interior of the switch cabinet (3). If the upper or lower limit temperature is exceeded or undercut, a fault indication is triggered.
- The green LED light (1) blinks and the LCD (5) displays the error number with temperature (°C/°F).
- ⊗ The ambient conditions and switch cabinet interior temperatures must correspond to the prescribed technical data; see [Technical data](#).
- ⊗ The ambient temperature must be less than 55°C; see [Air flow functional principle](#).

4.2 Multi-Controller operation

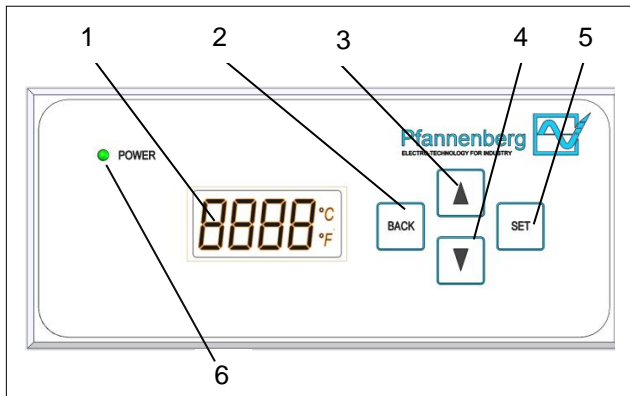

Figure 17 - Control panel (MC)

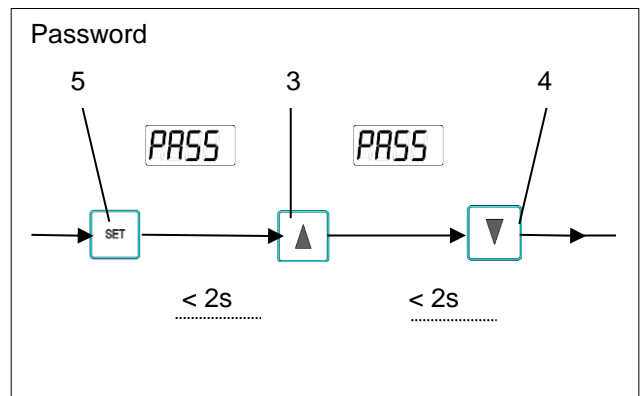

Figure 18 - Password button combination (MC)

The control panel has four menu settings that are displayed on the LCD (1).

LCD	Menu setting	Input
SEEP °C / °F	SetP: Switch cabinet temperature setpoint	0 – 90 °C
Lit ⁺ °C / °F	Lit ⁺ : Maximum switch cabinet temperature value (high limit value)	- 55 – 95 °C
Lit ₋ °C / °F	Lit ₋ : Minimum switch cabinet temperature value (low limit value)	- 55 – 95 °C
Unit °C / °F	Unit: Unit of the switch cabinet temperature	°C / °F

4.3 Carrying out menu settings

Requirement

- Cooling unit has started operation.
- LED light (6) of the control panel illuminates green.

Procedure

- Scroll through the menus (SetP, Lit⁺, Lit₋, Unit) from the temperature display (1) with the SCROLL UP (3) and SCROLL DOWN (4) buttons.
- Select a menu with the SET button (5).
- Enter the password. After pressing the SET button (5) press the SCROLL UP (3) and SCROLL DOWN (4) buttons within two seconds; see Password button combination figure.
- Always adjust the desired value with the SCROLL UP (3) and SCROLL DOWN (4) buttons.
- Confirm the value with the SET button (5).
- When the BACK button (2) is pressed, the value is not saved.
- Select a different menu by scrolling with the SCROLL UP (3) and SCROLL DOWN (4) buttons.
- ☒ If there is no input for 30 seconds, a TIMEOUT is initiated and the LCD switches to temperature display.

⇒ Menu is adjusted in the cooling unit.

Menu settings

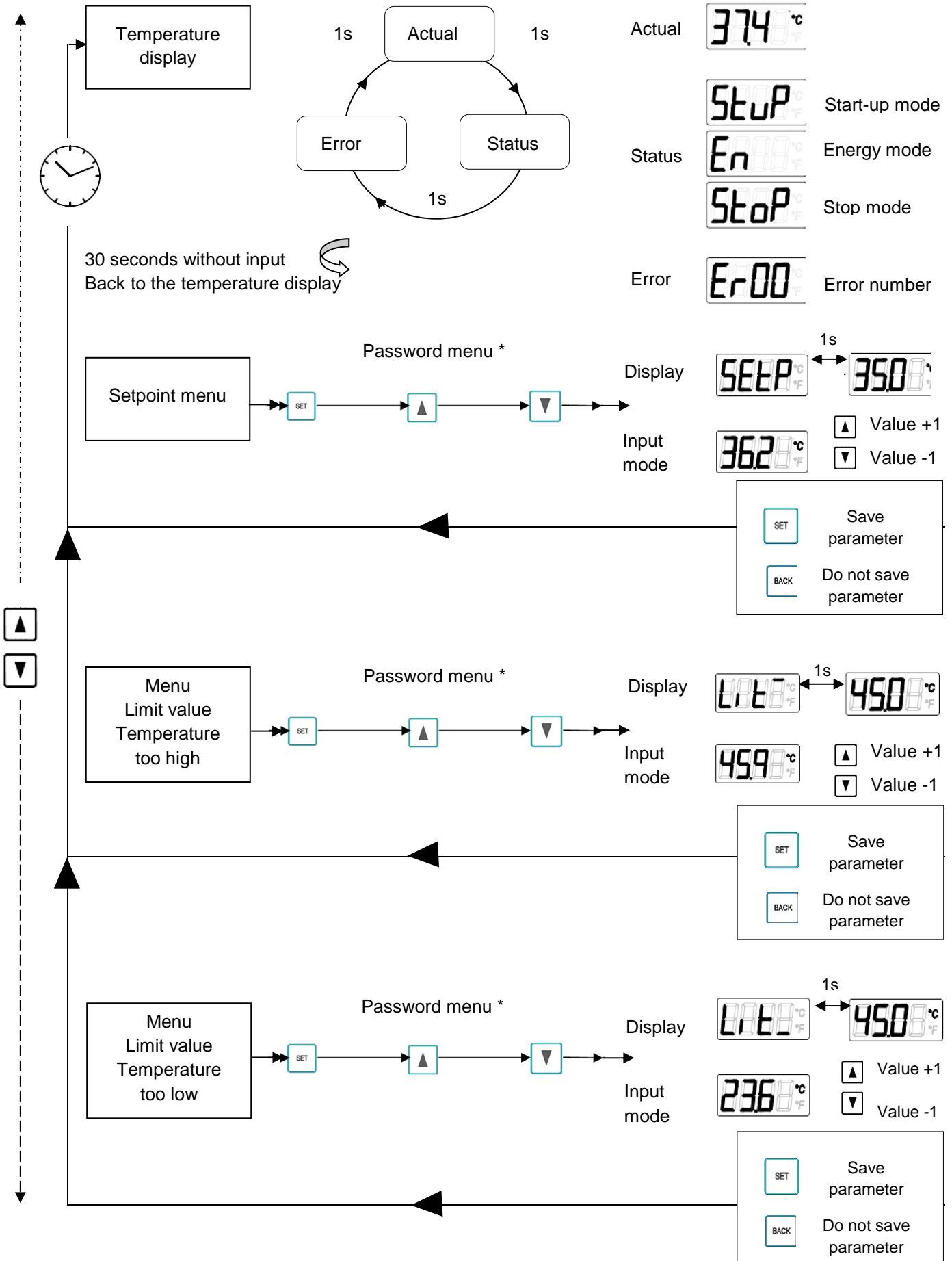

Menu settings

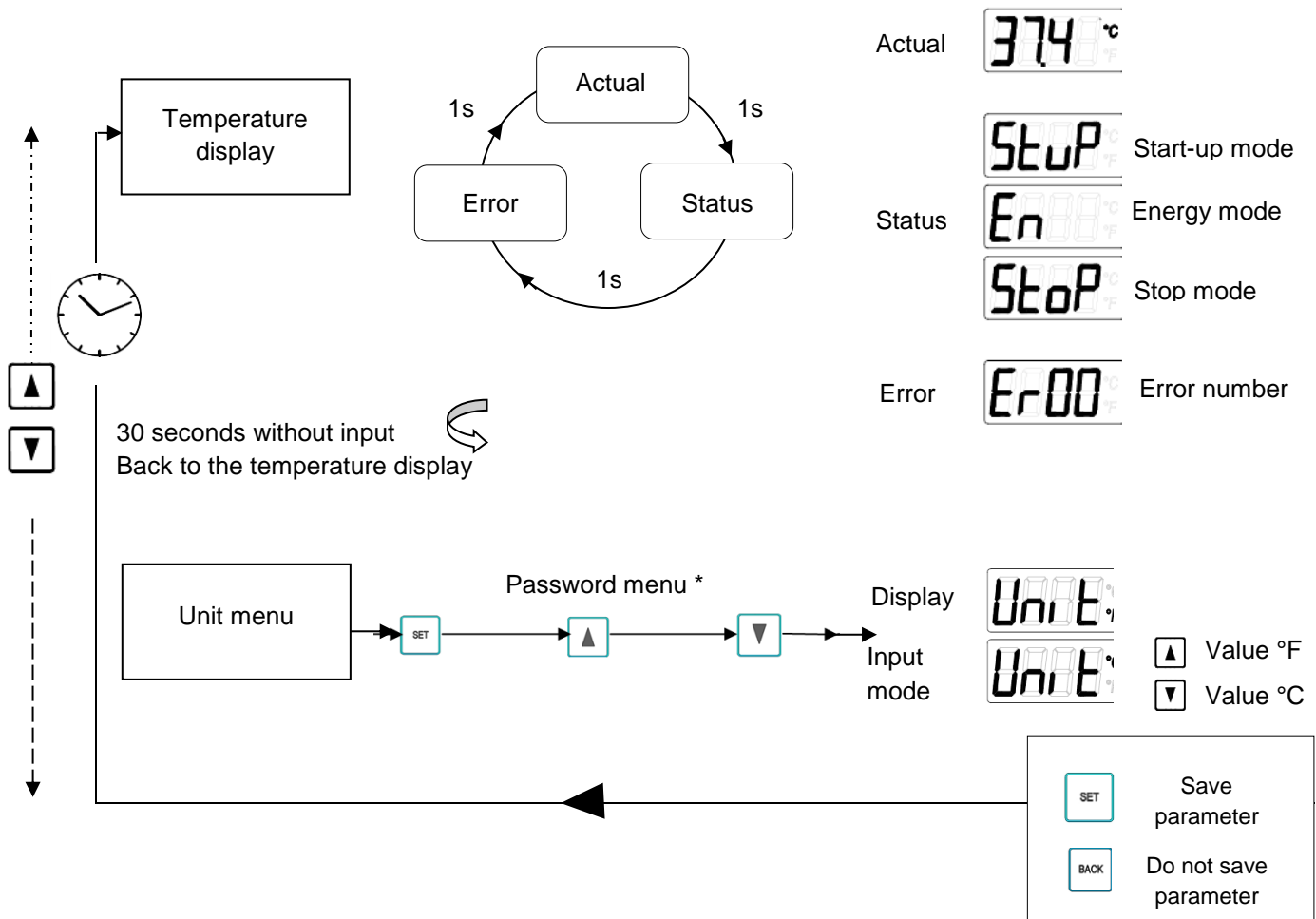

4.4 Operation of the cooling unit

- After connection of the mains voltage, the device switches to startup/test mode or directly to operating mode. The controller equipment determines which mode is activated.
- In operating mode the cooling unit switches to cooling mode as needed. This takes place depending on whether a temperature switching threshold (TSet) is reached or undercut.
- ☒ Cooling mode switches off when the temperature switching threshold (TSet) is undercut. It continues running if the temperature switching threshold (TSet) has not been reached yet.
- ☒ The evaporator fan (internal), condenser fan (external) and compressor switch off when the door is opened.

NOTE

Condensate flowing back into the switch cabinet can damage the electronic components

Internal temperatures below the dewpoint or damaged switch cabinet seals cause excessive accumulation of condensate.

- Regular inspection of the seals assures protection against heavy condensate accumulation.
- Ensure that the accumulating condensate can drain freely.

Operating conditions

- The mains voltage must lie within the specified range; see [Electrical data](#).
- ☒ A deviation of $\pm 10\%$ is permissible.
- The rated frequency must be within ± 3 Hz of the value specified.
- The ambient temperature must be below $55\text{ }^{\circ}\text{C}$. For further options, see [Technical data](#).
- ☒ The cooling unit must only be used in such a manner as to ensure that the specified cooling capacity is able to meet actual demands.
- ☒ Only the specified coolant may be used.

NOTE

Spare parts from third-party manufacturers can damage the unit

Internal temperatures below the dewpoint or damaged switch cabinet seals cause excessive accumulation of condensate.

- Only use specially harmonized manufacturer parts for safe and reliable operation.

- ☒ For Pfannenber spare part numbers, see [Spare part orders](#).

4.5 Service interface

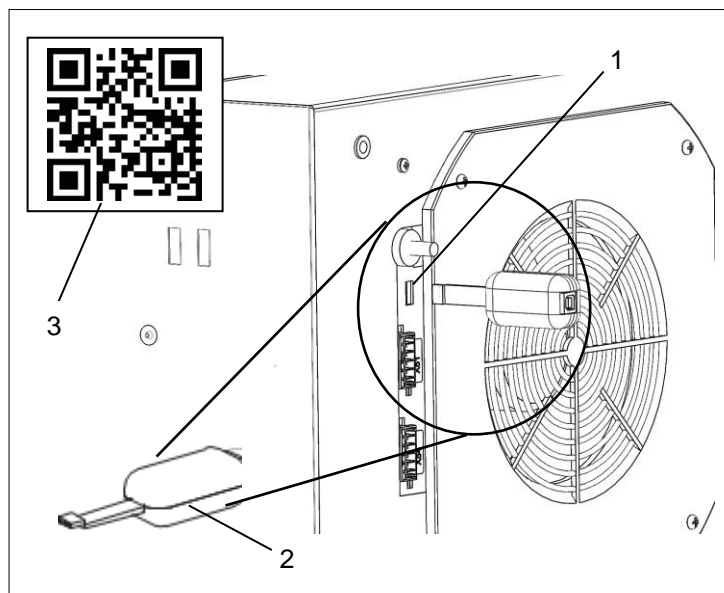

Figure 19 - Service

- The service interface (1) can be used to change operating parameters.
 - For this purpose, a USB adapter (2) and the ECoolPLANT 2.X configuration software and USB driver software are required.
 - The connection for the USB adapter is marked on the electrical circuit diagram with the identifier X28.
 - The USB adapter enables connection to a computer that works with the ECoolPLANT 2.X configuration software. The detailed use is described in the corresponding operating manual for the ECoolPLANT 2.X software.
 - Remove the USB adapter (2) from the unit after use. The service interface (1) is only provided for temporary data exchange in order to read system notifications, etc. Continuous operation is prohibited.
- ☒ The USB adapter is available as an accessory, see [Spare part orders](#).
 - ☒ The ECoolPLANT software (3) is available for download free of charge on the website: <https://www.pfannenber.com/> QR-Code (3).
 - ☒ The corresponding operating manual for the ECoolPLANT software is available [HERE](#) and from My Pfannenber.

4.6 Error messages

The error numbers are not displayed for units with standard controllers: With the ECoolPLANT software error numbers can be read on the computer.

☒ The blinking of the red LED light on the controller circuit board is **not** a fault indicator or error message. The red LED light indicates that voltage is supplied to the cooling unit.

Error no.	Fault	Unit activity	Possible causes	Corrective measures
Er00	<ul style="list-style-type: none"> • LED: • Compressor: • Evaporator fan (internal): • Condenser fan (external): • Heater (external): • Fault signal contact: 	Blinking OFF OFF OFF OFF Closed	<ul style="list-style-type: none"> • Door contact: • The door contact loop has been interrupted. 	<ul style="list-style-type: none"> ▪ Close door. ▪ Connect door contact switch. ▪ Bypass door contact. ▪ Check wiring.
Er01	<ul style="list-style-type: none"> • LED: • Compressor: • Evaporator fan (internal): • Condenser fan (external): • Heater (external): • Fault signal contact: 	Blinking OFF ON ON OFF Open	<ul style="list-style-type: none"> • Pressostat tripped: • Excessively high pressure has built up in the refrigerant circuit. The cooling unit cannot dissipate the heat from the refrigerant circuit. 	<ul style="list-style-type: none"> ▪ Allow the unit to cool down. ▪ Clean the heat exchanger fins (internal/external). ▪ Check condenser fan (external) for function.
Er04	<ul style="list-style-type: none"> • LED: • Compressor: • Evaporator fan (internal): • Condenser fan (external): • Heater (external): • Fault signal contact: 	Blinking OFF OFF OFF OFF Open	<ul style="list-style-type: none"> • Phase sequence / phase loss: • Failure of at least one phase or phase sequence is incorrect (only with alternating current units with rotating piston compressors). 	<ul style="list-style-type: none"> ▪ Check the field of rotation - (clockwise rotation is required). ▪ All phases must carry rated operational voltage.
Er05	<ul style="list-style-type: none"> • LED: • Compressor: • Evaporator fan (internal): • Condenser fan (external): • External heating: • Fault signal contact: 	Blinking ON ON ON OFF Open	<ul style="list-style-type: none"> • Sensor 1 (TS1) defective. 	<ul style="list-style-type: none"> ▪ Replace Sensor 1 or the controller circuit board according to the unit type. ▪ Replace controller circuit board if the sensor is soldered in place.



Error messages

Error no.	Fault	Unit activity	Possible causes	Corrective measures
Er06	<ul style="list-style-type: none"> • LED: • Compressor: • Evaporator fan (internal): • Condenser fan (external): • Heater (external): • Fault signal contact: 	Blinking OFF ON ON OFF Open	<ul style="list-style-type: none"> • Sensor 1 Minimum: • Minimum switch cabinet temperature value "Lit_" (LCD) is reached or exceeded. 	<ul style="list-style-type: none"> ▪ Select higher switch cabinet temperature setpoint. ▪ Inspect the switch cabinet for leaks. ▪ Move components near the air inlet and outlet further away in order to prevent an air short circuit. (Cold air is diverted directly to the air inlet by components.)
Er07	<ul style="list-style-type: none"> • LED: • Compressor: • Evaporator fan (internal): • Condenser fan (external): • Heater (external): • Fault signal contact: 	Blinking ON ON ON OFF Open	<ul style="list-style-type: none"> • Sensor 1 Maximum: • The maximum value of the switch cabinet temperature "Lit_" (LCD) has been reached or exceeded. • The cooling unit cannot sufficiently cool the air in the switch cabinet. 	<ul style="list-style-type: none"> ▪ Check the settings of the cooling unit. ▪ Clean the heat exchanger fins (internal/external). ▪ Check evaporator fan (internally) for functionality. ▪ Check the refrigeration circuit for escaping refrigerant or leaks. ▪ If necessary, install a cooling unit with a higher cooling capacity.
Er08	<ul style="list-style-type: none"> • LED: • Compressor: • Evaporator fan (internal): • Condenser fan (external): • Heater (external): • Fault signal contact: 	Blinking ON ON ON OFF Open	<ul style="list-style-type: none"> • Sensor 2 (TS2) defective. 	<ul style="list-style-type: none"> ▪ Replace Sensor 2 or the controller circuit board according to the unit type. ▪ Sensor 2 is plugged into the circuit board, not permanently soldered in place.

Error messages

Error no.	Fault	Unit activity	Possible causes	Corrective measures
Er15	<ul style="list-style-type: none"> • LED: • Compressor: • Evaporator fan (internal): • Condenser fan (external): • Heater (external): • Fault signal contact: 	<p>Blinking</p> <p>OFF</p> <p>OFF</p> <p>OFF</p> <p>OFF</p> <p>Open</p>	<ul style="list-style-type: none"> • Anti-freeze (optional): • Anti-freeze sensor $\leq 1^{\circ}\text{C}$. • Safety shut-off, because there is a risk of icing of the compressor. 	<ul style="list-style-type: none"> ▪ Restart after accumulating condensate water has evaporated. ☒ A restart is only possible with disconnection and re-connection of the mains voltage. ▪ For safety reasons, there is no other means of resetting. ▪ Clean the heat exchanger fins (internal/external). Inspect the switch cabinet for leaks. ▪ Select higher switch cabinet temperature setpoint. ▪ Check function of the evaporator fan (internal).
Er19	<ul style="list-style-type: none"> • LED: • Compressor: • Evaporator fan (internal): • Condenser fan (external): • Heater (external): • Fault signal contact: 	<p>Blinking</p> <p>OFF</p> <p>OFF</p> <p>OFF</p> <p>OFF</p> <p>Open</p>	<ul style="list-style-type: none"> • Sensor 5 (TS5) defective 	<ul style="list-style-type: none"> ▪ Replace Sensor 5 or the controller circuit board according to the unit type.

4.7 LCD error messages

Error no.	Control panel	Unit activity	System information
	<ul style="list-style-type: none"> • LED: • Compressor: • Evaporator fan (internal): • Condenser fan (external): • Heater (external): • Fault signal contact: 	Illuminated OFF OFF OFF OFF Closed	Energy saving mode: <ul style="list-style-type: none"> - Energy function execution, activated in energy saving mode. - For detailed information about energy saving mode, see Energy-saving mode.
	<ul style="list-style-type: none"> • LED: • Compressor: • Evaporator fan (internal): • Condenser fan (external): • Heater (external): • Fault signal contact: 	Illuminated OFF OFF OFF OFF Closed	Start-up mode <ul style="list-style-type: none"> - The cooling unit starts its operation
	<ul style="list-style-type: none"> • LED: • Compressor: • Evaporator fan (internal): • Condenser fan (external): • Heater (external): • Fault signal contact: 	Illuminated OFF OFF OFF OFF Closed	Stop mode execution. The unit was stopped due to: <ul style="list-style-type: none"> - Opening of the switch cabinet door. - The cooling unit received a stop command, e.g. via the software application.

5 Service and Maintenance

5.1 General cleaning



DANGER

Life-threatening danger due to electric shock

Live units and exposed connection cables can generate an electric shock and cause severe accidents.

- Work on electrical connections must be carried out exclusively by trained, qualified electricians.
- Before working on the unit, de-energize all supply lines to the separate fuse or a main switch, disconnect the system and secure to prevent re-connection.
- Test to ensure the absence of voltage on the unit.



WARNING

Danger of accidents due to component damage during cleaning

Cleaning of cooling units with water jet, steam jet, high-pressure washer or sharp objects can damage the electrical and electronic assemblies. Malfunctions can cause accidents.

- Do not clean with a water jet, pressure washer or flammable cleaning agents.
- Protect electrical components from the penetration of moisture.
- Do not use pointed or sharp-edged objects to clean the fins. They must not be pinched or damaged.



CAUTION

Danger of crushing during removal of the unit cover

Hands and other body parts can be crushed during removal and re-installation of the unit cover.

- Keep body parts out of the space between the frame, springs and unit cut-out.
- Work carefully and wear gloves.

The frequency of cleaning intervals depends on the operating conditions in the individual case. The following cleaning work must take place regularly for safe and reliable operation of the cooling units:

- Remove dust or environmental residue from the heat exchangers.
- Check the condensate drain regularly.

5.2 Cleaning the cooling unit - Unit cover removal

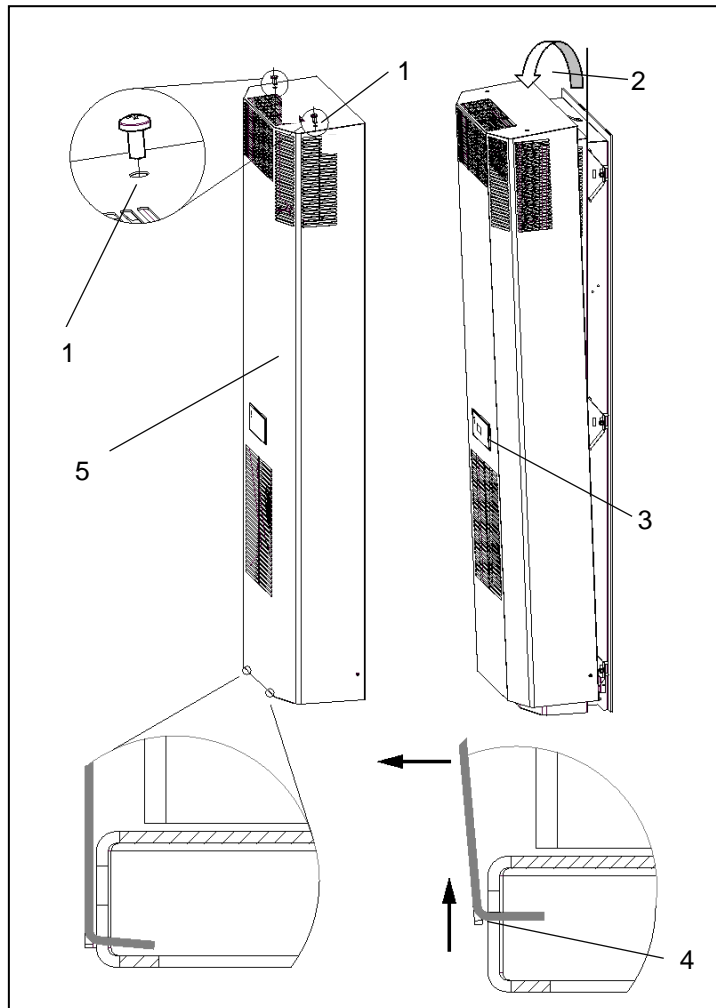

Figure 20 – Unit cover removal

Item	Designation	Item	Designation	Item	Designation
1	Fastening screws	2	Tilting angle 20°	3	Display or operating unit
4	Bottom plate slot	5	Unit cover		

Requirement

- The cooling unit is de-energized

Procedure

- Remove the fastening screws (1).
- Tilt the unit cover (5) forward 20° (2).
- Disconnect the earthing cable and connecting cables from the display or operating unit (inside) (3).
- Raise the unit cover about 15 mm and pull it out of the slots in the bottom plate (4).

⇒ The unit cover is removed.

5.3 Cooling unit and filter mat cleaning tasks

NOTE

Danger of damage to the filter mat due to improper cleaning

- Do not wring out the filter mat.
- Avoid water jets with high pressure.
- Immediately replace filter mats that are contaminated with oil or grease.

Requirements

- The cooling unit is de-energized.
- The unit cover is removed.

⊗ Time intervals for the cleaning or replacement of filter mats depend heavily on the ambient air contamination.

Required tools and material

- Brush
- Water below 40 °C
- Mild detergent
- Vacuum or compressed air cleaner

Procedure

- Clean the heat exchangers using a soft brush or compressed air.
- If the cooling units have a pre-filter, the filter mat must be cleaned at regular intervals.
- Wash the filter mat with water at a temperature of up to 40 °C and commercially available mild detergent.
- If the dirt is dry, vacuum, blow or knock the dirt off of the filter mat.
- Ensure that correct and safe operation is assured after cleaning.

⇒ *The cooling unit is clean.*

5.4 Maintenance



DANGER

Life-threatening danger due to electric shock

Live units and exposed connection cables can generate an electric shock and cause severe accidents.

- Opening, troubleshooting and replacement of components on the unit must only be carried out by qualified personnel.
- Always ensure that the unit is de-energized before working on the unit.



WARNING

Danger due to improper maintenance work

Damage of components and faulty replacement of components can cause accidents.

- Always switch off the disconnecter/contactator before beginning maintenance work.
- Ensure that the fans are in idle position and are no longer rotating.
- After replacement of defective parts or components, inspect the unit for correct and safe operation.
- After all maintenance or replacement of spare parts, check to ensure the full capability of the condensate drain.



WARNING

Spare parts from third-party manufacturers can damage the unit and cause accidents.

- Only original parts are subject to the manufacturer's quality control.
- Only use specially agreed manufacturer parts for safe and reliable operation.

NOTE

Danger of unit damage due to incorrectly performed maintenance

Disregard of the recommended maintenance work reduces the cooling capacity of the cooling unit and could result in reduced machine availability.

- Maintenance work must be carried out regularly, as specified in the maintenance checklist.
- Warranty claims are only valid for units that have been maintained according to specifications.

The refrigerant circuit is a maintenance-free, hermetically sealed system. The following preparations are made at the factory:

- Necessary refrigerant quantities are filled.
- All cooling units are tested for leakage in the factory in accordance with DGUV-R 100-500, 2.35 (operation of refrigeration plants, heat pumps and cooling equipment).
- A functional test run was carried out.

Pfannenberg recommendation to the operator for maintenance work:

- Carry out maintenance work regularly, every 12 months, according to the maintenance checklist; see [Maintenance checklist template](#).
- Shorter maintenance intervals are required for cooling units that cool in oil- and dust-laden ambient air. A reduced guideline value of two to six months between maintenance intervals applies.
- ☒ The functions of Pfannenberg filters are optimally matched to the cooling units. Therefore, use of Pfannenberg filters has a positive effect on the scope of maintenance work.

5.5 Maintenance checklist template

Cooling unit maintenance checklist				
Maintenance interval: Conduct maintenance every twelve months. Conduct maintenance every two to six months in oil- and dust-laden environmental air.				
Type: Serial number: Date of maintenance: Technician carrying out the work (name):				
	Unit range designation/ Required maintenance tasks	Visual inspection	To Do	Result
1	Aggregate before maintenance			
1.1	General visual inspection of the aggregate			
1.2	Inspection for corrosion damage			
2	Cooling circuit			
2.1	Inspect refrigerant-carrying parts for traces of oil			
2.2	Inspect refrigerant-carrying parts for leak tightness			
2.3	Inspect electrical connections for damage			
2.4	Inspect evaporator for ice formation			
3	Condenser / heat exchanger			
3.1	Inspect pipe package for deposits			
3.2	Inspection for general corrosion damage			
3.3	Inspect, clean, align fins*			
4	Evaporator / heat exchanger			
4.1	Inspect pipe package for deposits			
4.2	Inspection for general corrosion damage			
4.3	Inspect, clean, align fins*			
5	Condenser fan (external)			
5.1	Inspect mount for loose parts			
5.2	Inspect the electrical connection for damage			
5.3	Check motor bearings for noises			
5.4	Check the drive for signs of overheating			
5.5	Clean fans*			
6	Evaporator fan (internal)			
6.1	Inspect mount for loose parts			
6.2	Inspect the electrical connection for damage			
6.3	Check motor bearings for noises			
6.4	Check the drive for signs of overheating			
6.5	Clean fans*			
7	Pre-filter			
7.1	Replace filter mat*			
7.2	Clean filter mat*			

* Maintenance intervals are more frequent, depending on the degree of contamination.

5.6 Decommissioning

WARNING

Danger of injury due to materials and substances

Improper work on the unit or opening of the refrigerant circuit can be damaging to health.

- Always ensure that the unit is de-energized before working on the unit.
- The unit must only be disposed of by qualified personnel and in accordance with applicable environmental regulations.

If the cooling unit is no longer needed for a longer period, it must be disconnected from the voltage supply.

☒ Ensure that improper start-up by third parties is not possible.

Final decommissioning

CAUTION

Danger of crushing during the decommissioning of units

Hands and other body parts can be crushed during removal of units.

- Keep body parts out of the space between the frame, springs and unit cut-out.

If cooling units are to be definitively decommissioned or disposed of, the following must be observed:

- Applicable statutory regulations of the user country and environmental protection regulations must be observed.
- Refrigerant must be professionally extracted from the refrigerant system. Avoid refrigerant emissions.
- The cooling unit must only be disposed of by authorized, qualified personnel.

☒ Waste equipment must also be disposed of correctly by Pfannenberg. Freight charges for delivery to one of our manufacturing facilities must be pre-paid.

6 Troubleshooting

Fault	Possible causes	Corrective measures
Unit does not cool; Evaporator fan (internal) running	<ul style="list-style-type: none"> • Temperature setting too high. 	<ul style="list-style-type: none"> ▪ Check the temperature setting.
Unit does not cool sufficiently	<ul style="list-style-type: none"> • Operating limits exceeded. 	<ul style="list-style-type: none"> ▪ Check the ambient temperature and internal load.
	<ul style="list-style-type: none"> • Too little coolant. 	<ul style="list-style-type: none"> ▪ Call in authorized qualified personnel; check the unit for leakage.
	<ul style="list-style-type: none"> • Heat exchanger dirty. 	<ul style="list-style-type: none"> ▪ Clean the heat exchanger.
	<ul style="list-style-type: none"> • Evaporator fan (internal) defective. • Condenser fan (external) defective. 	<ul style="list-style-type: none"> ▪ Call in authorized, qualified personnel; replace fan.
	<ul style="list-style-type: none"> • Disruption in the air circulation inside the cabinet. 	<ul style="list-style-type: none"> ▪ Check the installation and the path of air circulating in the switch cabinet. ▪ Check the supply and outlet flow of air of the cooling unit to the inlet and outlet opening of the switch cabinet.
Unit cools only periodically	<ul style="list-style-type: none"> • Temperature set incorrectly or unit is defective. 	<ul style="list-style-type: none"> ▪ Set the a higher temperature. ▪ Call in authorized qualified personnel, check the unit.
Condensate accumulates in the switch cabinet	<ul style="list-style-type: none"> • Exhaust temperature is too low. 	<ul style="list-style-type: none"> ▪ Close the cabinet door.
	<ul style="list-style-type: none"> • Switch cabinet is not sufficiently sealed. 	<ul style="list-style-type: none"> ▪ Correct leaky points or seals on the switch cabinet. ▪ Check the temperature setting.
Condensate does not drain	<ul style="list-style-type: none"> • Condensate drain is plugged up. 	<ul style="list-style-type: none"> ▪ Clean the condensate drain. ▪ Check whether the condensate drain hose is free from kinks and is installed with a downward slope.
Condensate drains from the unit	<ul style="list-style-type: none"> • Condensate evaporator is defective or too much condensate accumulates. 	<ul style="list-style-type: none"> ▪ Replace fuses for the condensate evaporator.
	<ul style="list-style-type: none"> • Switch cabinet is not sufficiently sealed. 	<ul style="list-style-type: none"> ▪ Correct leaky points or seals on the switch cabinet.

☒ The blinking of the red LED light on the controller circuit board is not a fault indicator or error message. The red LED lamp indicates that voltage is supplied to the cooling unit.

7 Spare part orders / accessory orders

No.	Designation	No.	Designation
18811100065	Evaporator fan (internal)	18811100065	Condenser fan (external)
18810200144	Unit cover DTI 62/6301C RAL	18810200145	Unit cover DTS 62/6301C RAL
18810000058	Multi-Controller (MC) control panel	18810000001	Standard controller (SC) display unit
18314000100	Condensate collecting bottle	18310000004	USB adapter
18310000151	Filter adapter	18300000147	Fleece filter
18300000148	Fluted filter	18300000149	Metal filter

- ☒ Always specify the Pfannenberg part numbers when ordering spare parts and accessory parts.
- ☒ The Pfannenberg part numbers for the controller are provided on the transformer of the controller.

8 Terms of warranty

The warranty does not apply or is voided in the following cases:

- Improper use of the unit.
- Failure to observe operating conditions or disregard of the operating manual.
- Lack of regular maintenance on the cooling units.
- Damage due to disregard of maintenance recommendations.
- Damage to cooling units due to soiled or clogged filters.
- Damage due to unauthorized opening of the refrigerant circuit.
- Modifications carried out on the unit or a change to the serial number.
- In the event of damage during transport or other accidents.
- Replacement of parts by unauthorized personnel.

- ☒ Only original Pfannenberg parts are permitted for use. Violations void the warranty.

For recognition of warranty claims and return of the unit, observe the following:

- Provide an exact description of the defect and the SRO (RMA) numbers specified by Pfannenberg with the cooling unit.
- Include a reference document (delivery note or invoice copy).
- Forward the cooling unit to us, complete with all accessories, in the original box or in comparable packaging with freight and transport insurance pre-paid.

Observe transport instructions; see [Transport](#).

Liability disclaimer:

All information contained was thoroughly checked in May 2017.

However, we make no guarantee as to the completeness and correctness of the specifications.

Legal notice:

Pfannenberg GmbH

Werner-Witt-Straße 1

21035 Hamburg

Tel. +49 40 734 12-0

www.pfannenberg.com

© Pfannenberg 2017

Operating Manual

Attachment and installation cooling units
DTS and DTI Series 6201C / 6301C
Multi-Controller (MC) – 400 V 2~

Version 1.0, May 2017



Preface

The skills and information provided in the ORIGINAL OPERATING MANUAL are required for assembly and safe operation of Pfannenberg cooling units.

The information is presented in a brief, clearly arranged format. The chapters are numbered throughout. If you have the operating manual in digital format, the links are **interactive**.

Various unit types are documented in this operating manual.

Pfannenberg cooling units are subject to continuous improvement. Please understand that we must reserve the right to changes in design, equipment and technology. For this reason, no claims to specific features of the unit can be derived from the content of this operating manual.

☒ A film on the DTI cooling units can be viewed **HERE**.

Safety instructions and markings



Identifies an exceptionally dangerous situation. Severe, irreversible injuries or death will occur if this notice is not observed.



Identifies an exceptionally dangerous situation in connection with electrical voltage. Severe, irreversible injuries or death will occur if this notice is not observed.



Identifies an exceptionally dangerous situation. Severe, irreversible or deadly injuries could occur if this notice is not observed.



Identifies a dangerous situation. Minor or moderate injuries could occur if this notice is not observed.

☒ Before notices and explanations.

* Legend notice

⇒ *Placed before results of actions.*

Table of contents

1	Intended use	5
1.1	General overview	5
1.2	Permissible usage conditions	5
1.3	Duty of the operator	5
2	Unit description	6
2.1	Description of use	6
2.2	Scope of delivery	6
2.3	Order options	6
2.4	Functional description	7
2.4.1	Air flow functional principle	7
2.4.2	Controller	8
2.4.3	Refrigerant circuit functional principle	9
2.4.4	Safety concept	9
2.4.5	Accumulation of condensate	10
2.4.6	Energy-saving mode	10
2.4.7	Multimaster function	11
2.5	Type plate	12
2.6	Technical data	13
2.6.1	Refrigeration data	13
2.6.1	Electrical data	13
2.6.2	Dimensions	13
2.6.3	Other unit data	13
3	Assembly and initial commissioning	14
3.1	Transport	14
3.2	Storage	14
3.3	Unpacking	15
3.4	Assembly	15
3.4.1	General assembly requirements	16
3.4.2	Mounting M8 jack rings	16
3.4.3	DTS cooling unit assembly (side attachment)	17
3.4.4	DTI cooling unit assembly (installation)	19
3.5	Electrical connection	21
3.5.1	Multi-Controller (MC) electrical circuit diagram	21
3.5.2	Multimaster connection	21
3.5.3	Door contact switch	22
3.5.4	Mains supply connection	23
3.5.5	Adapting the upstream fuse /transformer options	25
3.5.6	Collective fault signal	25

4	Operation	26
4.1	General functions.....	26
4.2	Multi-Controller operation	27
4.3	Carrying out menu settings.....	27
4.4	Operation of the cooling unit.....	29
4.5	Service interface	30
4.6	Error messages.....	31
4.7	LCD error messages.....	34
5	Service and Maintenance	35
5.1.	General cleaning.....	35
5.2	Cleaning the cooling unit - Unit cover removal.....	36
5.3	Cooling unit and filter mat cleaning tasks	37
5.4	Maintenance	38
5.5	Maintenance checklist template.....	39
5.6	Decommissioning	40
6	Troubleshooting.....	41
7	Spare part orders / accessory orders	42
8	Terms of warranty	42

1 Intended use

1.1 General overview

The Pfannenberg attachment and installation cooling units of the DTS and DTI series are stationary cooling units for the dissipation of heat from switch cabinets. They are available in two versions:

- The DTI cooling units are partially recessed in the side or installed in the door.
- The DTS cooling units are mounted on the side or on the door.

The cooling units have different cooling outputs. For exact watt specifications, see [Technical data](#).

The cooling units have cut-out compatibility with air/air heat exchangers and air/water heat exchangers. Use of aluminum filters, fleece filters and fluted filters is possible with an additional adapter.

The cooling units are available with different controllers. Cooling units are available with a standard controller (SC) or a Multi-Controller (MC). These controllers are regulating units for the adjustment of refrigeration functions and operating data. They also enable readouts of system messages and diagnostic data. The Multi-Controller (MC) is also equipped with a Multimaster function and energy saving mode.

☒ For detailed specifications for the controller, see [Technical data](#), [Electrical connection](#) and [System information](#).

All Pfannenberg cooling units are ROHS-compliant and free from:

- Silicone connections
- PCT, asbestos, formaldehyde, cadmium
- Moisture-impairing substances

1.2 Permissible usage conditions

- The permissible ambient air temperature range of DTI/DTS cooling units is +15°C (+59°F) to +55°C (+131°F).
- The permissible storage temperature of DTI/DTS cooling units must not exceed +70 °C (+158°F).

1.3 Duty of the operator

The operator must ensure that the cooling units are used exclusively as intended and dangers of all types to the life and limb of users or third parties are avoided. In addition, accident prevention regulations and recognized safety rules are to be observed.

The operator must ensure that all users have read and understood this operating manual.

Non-observance of this operating manual will void the warranty. The same applies if improper work has been carried out on the unit by the customer and/or third parties without the approval of the manufacturer.

2 Unit description

2.1 Description of use

Pfannenberg DTS and DTI series attachment and installation cooling units are designed to dissipate heat from switch cabinets. Sensitive components in the switch cabinet are protected. Condensate arising during the cooling is removed by an integrated system.

☒ The cooling units operate with very low flammable refrigerant that is not harmful to the ozone layer.

2.2 Scope of delivery

The shipment consists of the following contents:

- DTI/DTS cooling unit
- Cooling unit quick guide
- Accessory kit: Appropriate seal, fastening material, electrical plug connector, etc. for the specific unit type
- Special accessories, if applicable

2.3 Order options



Spare parts from third-party manufacturers can damage the unit

- Only original parts are subject to the manufacturer's quality control.
- Only use specially harmonized manufacturer parts for safe and reliable operation.

☒ For Pfannenberg spare part numbers, see [Spare part orders](#).

There is an optional expansion with a filter adapter for various filter mats (fleece filters, fluted filters and metal filters).

☒ For Pfannenberg part numbers for accessory orders, see Ordering of [accessory parts](#).



Danger due to impermissible use of units

Inappropriate use of the units can cause severe accidents.

- Cooling units must only be used in stationary operation.

The DTI/DTS cooling units are only approved for stationary operation. As cooling units with protection rating IP 54, the cooling units are essentially dust-protected. Limitation: Dust can still penetrate after continuous exposure. The cooling units are resistant to spray water, but not a constant water jet.

2.4 Functional description

2.4.1 Air flow functional principle

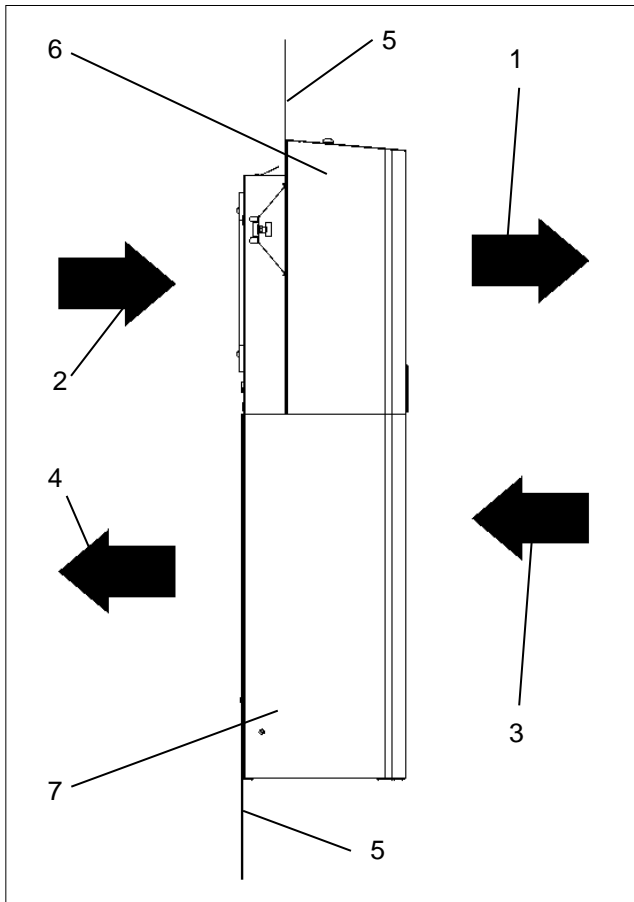

Figure 1 - DTS/DTI switch cabinet air flow principle front view

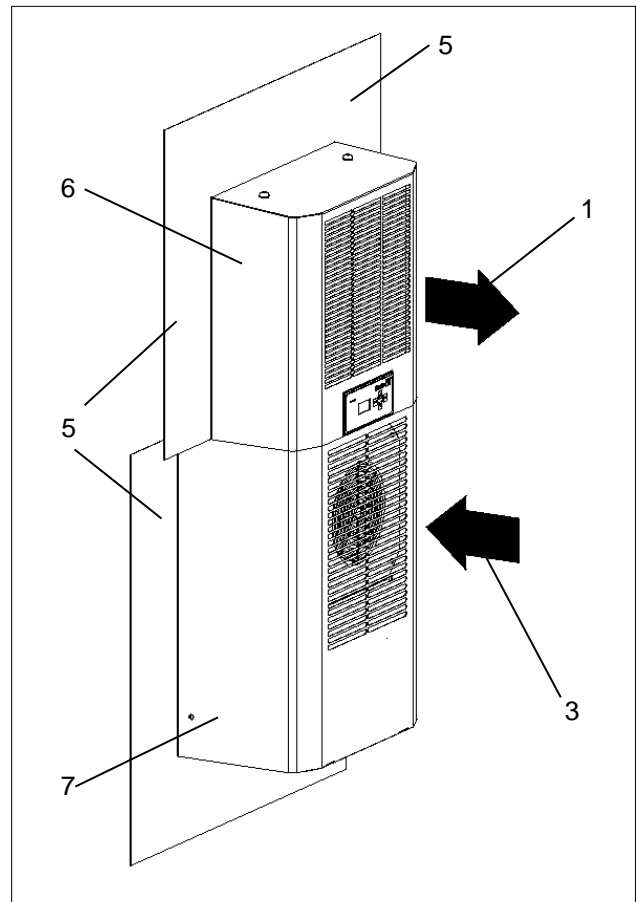

Figure 2 - DTS/DTI switch cabinet air flow principle side view

Item	Designation	Item	Designation
1	Ambient air outlet	2	Warm air inlet
3	Ambient air inlet	4	Cold air outlet
5	Switch cabinet	6	DTI unit cover
7	DTS unit cover		

☒ The upper part of the figures – Air flow principle front view – shows the DTI cooling unit and the lower part shows a DTS cooling unit.

CAUTION

Danger due to the release of very warm air

The air outlet can become very warm depending on the ambient temperature.

- Keep body parts away from the air outlet.

☒ For the ambient temperature and air outlet ratio, see [Technical data](#).

2.4.2 Controller

Controllers are regulating units for the adjustment of refrigeration functions and operating data. They enable readouts of system messages and diagnostic data. The controllers have a service interface which enables various configurations. There is also a connection for collective fault indications.

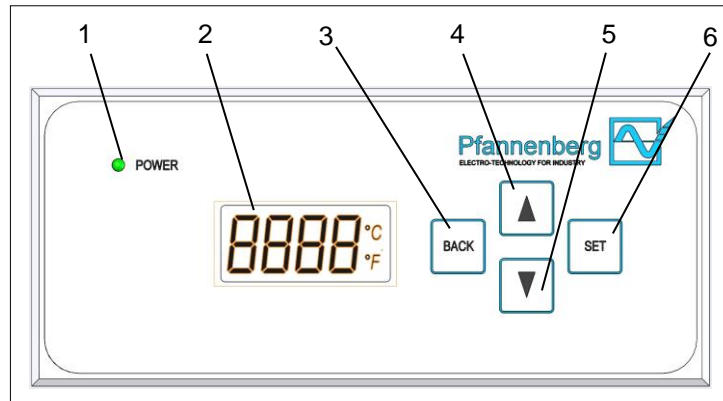

Figure 3 - Multi-Controller (MC) control panel

Item	Control panel	Function
1	Green LED light	- Displays the operating mode: Permanently illuminated = fault-free / blinking = operational fault
2	LCD (4-digit)	- Displays system information: Temperature measuring unit, energy function, operating mode, system data, error number and menu settings / menu items / menu level.
3	BACK button	- Activation of menu settings. - Jump back to the next higher menu level.
4	SCROLL UP button	- SCROLL UP through the menu items or display elements in the current menu level
5	SCROLL DOWN button	- SCROLL DOWN through the menu items or display elements in the current menu level
6	SET button	- Selection of the current menu item. - Jump to the next lower menu level.

Cooling units with a multi-controller (MC) have a control panel with a green LED light (1) and an LCD (2). They are located on the unit cover. Permanent illumination of the green LED light (1) while the mains voltage is connected indicates fault-free operation. System information is displayed in the LCD. The following system information can be displayed:

LCD	System information
	Display – Temperature (°C/°F) of the regulating sensor in normal operating status.
	Display – Stop mode execution. Door is open. Alternating display with temperature and stop mode, with fault Er00. Display: StoP →Er00→Temperature.
	Display – Energy function execution, activated in energy saving mode Alternating display with temperature display (°C/°F).
	Display – Error number when a fault occurs. In case of a fault, error number (Er01-Er15) is displayed alternating with temperature (°C/°F). Exception, fault ER00: Display StoP →Er00→Temperature.

In case of an operating fault or a malfunction, the gray LED light (1) begins to blink and the LCD (2) displays error numbers alternating with the temperature. For details, see [Error messages](#) .

2.4.3 Refrigerant circuit functional principle

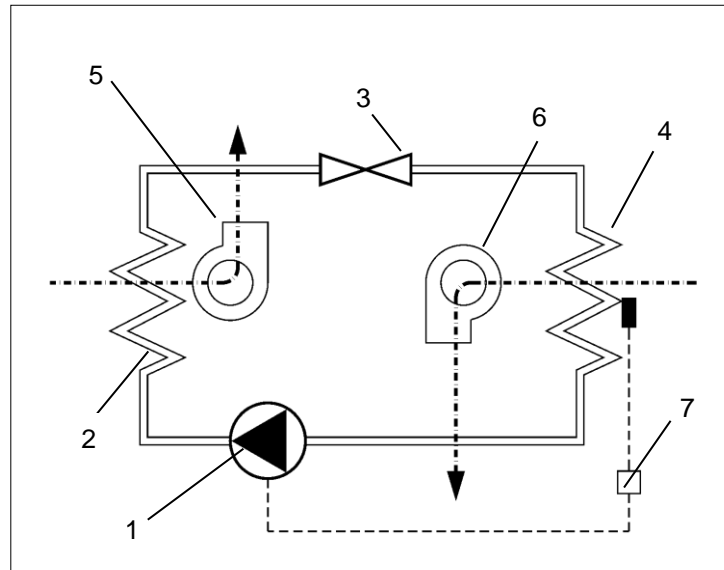

Figure 4 - Refrigerant circuit

Item	Designation	Item	Designation
1	Compressor	2	Condenser
3	Expansion valve	4	Evaporator
5	Condenser fan (external)	6	Evaporator fan (internal)
7	Electronic control with temperature sensor		

The cooling units are comprised of various components; see the figure Refrigerant circuit.

- The compressor (1) compresses the refrigerant under high pressure. The temperature increases.
- This heat is released to the ambient air in the condenser (2). The refrigerant liquefies.
- The condenser fan (5) draws room air through the condenser (2) and releases it to the environment.
- A pressure drop occurs when the refrigerant passes through the expansion valve (3).
- Inside the evaporator (4), the refrigerant absorbs heat from the air inside the switch cabinet and evaporates. The air inside the switch cabinet is cooled and dehumidified.
- The evaporator fan (internal) (6) draws the air inside the switch cabinet through the evaporator (4) and releases the cooled air back to the switch cabinet.

- ☒ The cooling units are controlled with a temperature sensor (7). It detects the air temperature inside the switch cabinet.

2.4.4 Safety concept



WARNING

Danger due to modified safety equipment

Non-functioning or defective safety equipment can cause severe accidents.

- Any changes to the unit, particularly the safety equipment, are prohibited.
- In case of defective safety equipment, shut down the unit and decommission it immediately.

- Cooling units have a pressure switch tested in accordance with EN 12263. It reacts to a pressure increase in the refrigerant circuit by shutting off automatically.
- Fans and compressors are protected from overloading and overheating: e.g. the compressor is protected against overlocking.

Additional protective functions (only cooling units with anti-freeze option):

- If there is a risk of ice formation, switch off the compressor and the fans.
- This shut-off function is not withdrawn until a system restart.

2.4.5 Accumulation of condensate

NOTE

Condensate flowing back into the switch cabinet can damage the electronic components

Internal temperatures below the dewpoint or damaged switch cabinet seals cause excessive accumulation of condensate.

- Regular inspection of the seals assures protection against heavy condensate accumulation.
- Installation of a door contact switch reduces the accumulation of condensate when the switch cabinet is open.

If the evaporator cools down, condensate can accumulate. In order to prevent damage to the switch cabinet and the cooling units, the condensate is removed. The integrated condensate evaporator releases the condensate to the environment. For safety reasons, there is a drain port with drain hose on the condensate evaporator.

☒ Accumulating condensate is collected by a condensate collecting bottle. It is available as an accessory.

☒ In case of questions about the cooling units or accessories and spare part orders, always specify the serial number; see [Spare part orders](#).

2.4.6 Energy-saving mode

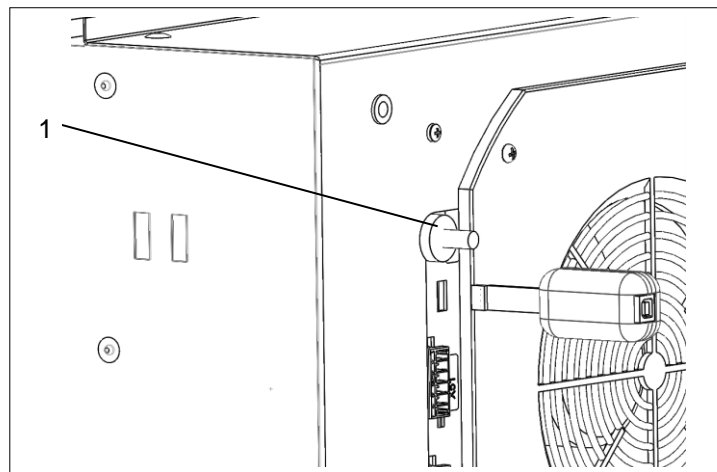

Figure 5 – TS2- Temperature sensor

Cooling units with Multi-Controller (MC) are equipped with energy-saving mode. Therefore, it has a second TS2 temperature sensor (1), which is installed externally on the cooling unit. The TS2 temperature sensor (1) monitors the switch cabinet interior temperature.

- In the condition as supplied, energy-saving mode is activated when cooling operation is not activated for 30 minutes. The LCD then displays energy function "EN", [see system information](#)
- If the switch cabinet interior temperature increases above the adjusted temperature setpoint during active operation, a cooling command is sent and energy saving mode is interrupted.
- Cooling mode remains active until the temperature setpoint, minus hysteresis, has been reached. Energy-saving mode always activates 30 minutes after the temperature setpoint is reached.
- If the temperature setpoint is undercut by the external TS2 temperature sensor (1) in energy-saving mode, the evaporator fan (internal) switches off. The temperature setpoint is measured minus hysteresis.
- If the external TS2 temperature sensor (1) detects a temperature that exceeds the temperature setpoint, the evaporator fan (internal) switches on. The value of the temperature setpoint is measured plus hysteresis.
- If no fault occurs, the fault indication output is closed in energy saving mode.

2.4.7 Multimaster function

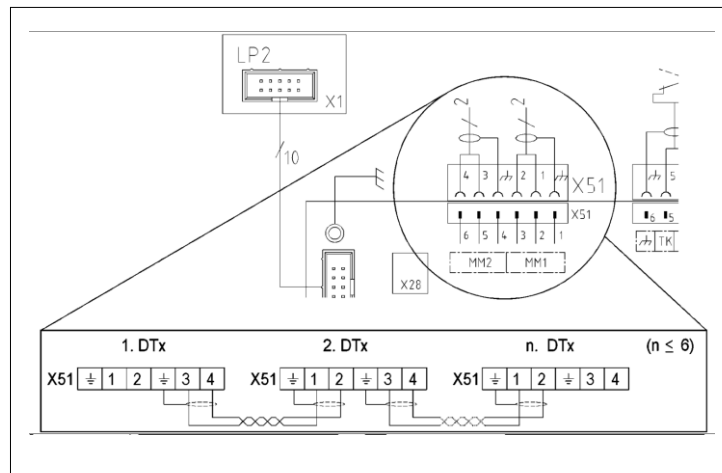

Figure 6 – Multimaster control

- The Multimaster function can control up to six connected cooling units (bus functions). It regulates the cooling mode as follows:
 - The first cooling unit that reaches the "TSet + 2K" switching threshold activates cooling mode in the bus function.
 - The cooling mode is ended by the last unit that undercuts the switching threshold "TSet - 2K".
 - Energy-saving mode is ended by the cooling command of one of the cooling units in bus function.
 - Energy-saving mode is re-activated 30 minutes (condition as supplied) after the last cooling command of one of the cooling units in the bus function.
- ☒ All cooling units in the bus function can activate or end cooling mode or energy-saving mode. There is no "master and slave function".
- ☒ For electrical connection, see [Electrical connection](#).

2.5 Type plate



WARNING

Danger due to damage of units

Disregarding type plate specifications can result in severe accidents.

➤ Always observe the specifications on the type plate when installing and maintaining the units.

- ☒ The type plate is located on the rear side of the cooling unit housing.
- ☒ The figure shows the standard version for EU Member States. The type plate version may differ in other countries.

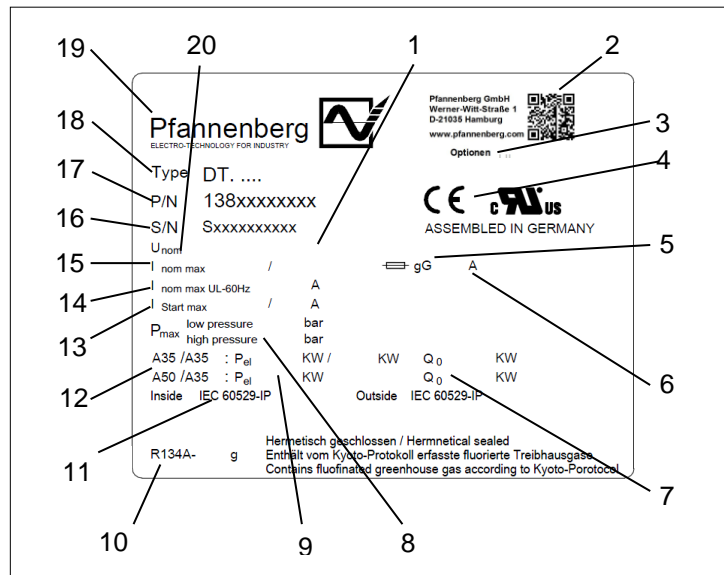

Figure 7 - Type plate for EU Member States

Item	Designation	Item	Designation
1	Frequency	2	QR code
3	Options	4	CE mark
5	Protection type	6	Protection
7	Cooling capacity	8	Coolant pressure
9	Power rating	10	Coolant
11	Protection type	12	Exterior / interior ambient conditions
13	Start-up current	14	Nominal current (UL 60 HZ)
15	Nominal current	16	Serial number
17	Part number	18	Unit type
19	Manufacturer logo	20	Rated operating voltage

2.6 Technical data

2.6.1 Refrigeration data

Designation		Model DTI/DTS 6201C	Model DTI/DTS 6301C
Cooling capacity A35 / A35 * / **	Q ₀	1000 W	1500 W
Cooling capacity A50 / A35 * / **	Q ₀	590 W	850 W
Refrigerant type *		R 134a	
Refrigerant quantity *		500 g	
Temperature setpoint (factory setting)		+35°C (+95°F)	
Fault indication: Switch cabinet interior temperature (factory setting)		> +50°C (+122°F)	
Ambient air temperature		+15°C (+59°F) bis +55°C (+131°F)	
Switch cabinet interior temperature		+25°C (+77°F) bis +45°C (+113°F)	
Air volume flow, exterior circuit		885 m ³ /h	
Air volume flow, interior circuit		885 m ³ /h	
Condensate separation		Condensate evaporator	

2.6.1 Electrical data

Designation		Model DTI/DTS 6201C		Model DTI/DTS 6301C	
Rated operating voltage * / ****		400 V 2~			
Rated frequency *		50 / 60 Hz			
Functional range		DIN IEC 60038			
		50 Hz	60 Hz	50 Hz	60 Hz
Power consumption *	P _{el} A35/A35	480 W	570 W	770 W	820 W
Rated current*	I _{nom max}	1,8 A	2,1 A	3,5 A	3,3 A
Starting current*	I _{Start max}	9,1 A		16 A	

2.6.2 Dimensions

Description	Model DTI/DTS 6201C	Model DTI/DTS 6301C
Height DTS	968 mm	
Height DTI	962 mm	
Width	410 mm	
Depth with cover (standard)	253 mm	
Installation depth DTI	60 mm	
Weight	DTI: 46 kg / DTS: 47 kg	DTI: 50 kg / DTS: 51 kg
Installation attitude	Vertical	
Unit construction	Standard: Steel sheet	

2.6.3 Other unit data

Designation	Model DTI/DTS 6201C	Model DTI/DTS 6301C
Anti-corrosion protection	Standard: Galvanized, electrostatic powder-coated (200°C) Variant: Stainless steel cover	
Protection type	When used as intended: IP 54 against the switch cabinet (EN 60529). IP 34 against the environment (EN 60529).	

* Data on the type plate.

*** Max. rated current UL at 60 Hz.

** Use of optional filter mats reduces the cooling capacity.

**** With a change to the rated operating voltage, adapt the upstream fuse; see [Adapting the upstream fuse](#).

3 Assembly and initial commissioning

3.1 Transport

WARNING

Danger due to uncontrolled movements

Improper securing of the unit can result in severe accidents.

- Loading must only be carried out by trained, qualified personnel.
- Lash the unit correctly for transport on a truck or trailer.
- Only use lashing straps with an adequate rated strength.
- Use slip-resistant materials for securing, e.g. anti-slip mats.
- When loading by crane, do not walk or stand under the raised units.

NOTE

Danger of material damage during transport and setting down of the units.

- Improper device securing or uncontrolled movements can cause damage.
- Exercise maximum caution during movement and transport of the units.
- Always transport the unit in the position of use.

Always transport the cooling units using the packaging provided by the factory. It comprises an outer carton, base plate and padding at the top and base.

Transporting cooling units

Requirements

- Cooling units must be in the packaging provided by the factory.

Required tools and material

- Lashing straps, loading crane, if applicable

Procedure

- Secure correctly for transport with lashing straps. Always transport in the position of use.
- Always raise cooling units by the housing.
- Always raise cooling units slowly and evenly and set down safely.

⇒ *The cooling unit was transported and loaded correctly.*

- ☒ The cooling unit can also be loaded using M8 jack rings; for this purpose, the M8 jack rings are first screwed into the cooling unit; see Mounting **M8 jack ring**.

3.2 Storage

- Do not expose the cooling unit to temperatures above +70 °C during storage.
- Always store the cooling unit in the position of use.
- ☒ The warranty will no longer apply if these instructions are not observed.

3.3 Unpacking

WARNING

Danger of accidents due to the heavy weight of the units

Uncontrolled movements of the units during assembly can cause accidents.

- Use suitable lifting equipment and secure units to prevent accidents.
- Also secure assembled components.

CAUTION

Danger of injury due to sharp edges

- For manufacturing reasons, the metal edges of the unit may have burrs.
 - Wear gloves during service and assembly work.
-
- Perform a visual inspection for transport damage when unpacking the cooling units. Take note of any loose parts, dents, scratches, visible loss of oil etc.
 - Inspect and secure the packaging material for any loose functional parts before disposal.
- ☒ Report any damages to the freight carrier immediately. Observe the "Terms for Cases of Damage".
- ☒ Precise information about defects, including possible photos must be provided for the handling of warranty claims. Always specify the type designation and serial number.
- ☒ The "General Terms for Deliveries and Services" of ZVEI (Zentralverband der Elektrotechnischen Industrie; Central Association of the Electrical Engineering and Electronics Industry in Germany) according to the latest revision apply.

3.4 Assembly

DANGER

Life-threatening danger due to electric shock

Live units and exposed connection cables can generate an electric shock and cause severe accidents.

- Work on electrical connections must be carried out exclusively by trained, qualified electricians.
- Before assembly, de-energize all supply lines to the separate fuse or a main switch, disconnect the system and secure to prevent re-connection.
- Test to ensure the absence of voltage on the unit.

CAUTION

Danger of crushing during assembly of the unit

There is a danger of crushing between the switch cabinet and frame of the unit during assembly.

- Keep body parts out of the space between the frame and unit cut-out.
- Work carefully and wear gloves.

NOTE

Switch cabinet installation hazard due to assembly chips

When making the cooling unit cut-outs, assembly chips can fall into the switch cabinet.

- When assembling the switch cabinet, protect against contaminants and use protective covers.

3.4.1 General assembly requirements

The following general requirements must be followed for safe and reliable operation of the cooling units:

- Select an assembly location for the switch cabinet which will guarantee adequate ventilation of the cooling unit. A minimum clearance of 200 mm between units and the nearest wall must be observed.
- Installed components in the switch cabinet must not impede air circulation.
- Secure the switch cabinet against tipping.
- Ensure that provided hinges can support the additional weight of the cooling unit.
- The cooling unit can be assembled with and without an external unit cover.
- Protect the installation location from heavy contamination with covers.

3.4.2 Mounting M8 jack rings



WARNING

Danger of accidents due to unapproved crane transport

Movement of switch cabinets with integrated cooling units can result in accidents.

- Only lifting by M8 jack rings is permitted for the cooling unit.
- Ensure that jack rings and unit threads are not damaged or deformed.
- Only use jack rings with an adequate thread length and ensure that they are securely seated.

The cooling units have threads for M8 jack ring installation. M8 jack rings can be installed in cooling units for crane transport.

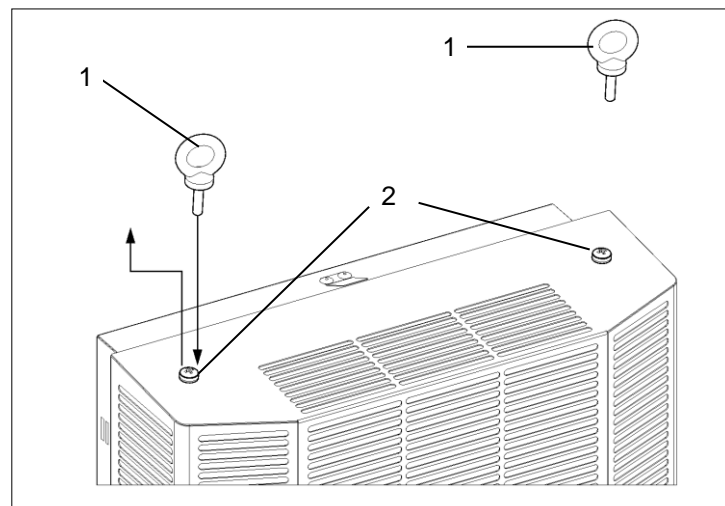

Figure 8 - DTI/DTS cooling unit M8 jack rings

Item	Designation	Item	Designation
1	DTS cooling unit M8 jack rings	2	Unit cover screws

Requirements

- The factory-provided packaging has been removed from the cooling units.
- Observe the minimum screw depth of the M8 jack rings.
- M8 jack rings and cooling unit threads must be free from damage (corrosion and deformation).
- The unit cover screws (2) have been removed.

Procedure

- Screw in the two M8 jack rings (1) completely with the appropriate thread depth.
- Check to ensure the proper seating of the M8 jack rings in the cooling unit.

⇒ The M8 jack rings are screwed in the cooling unit and the unit can be moved.

3.4.3 DTS cooling unit assembly (side attachment)

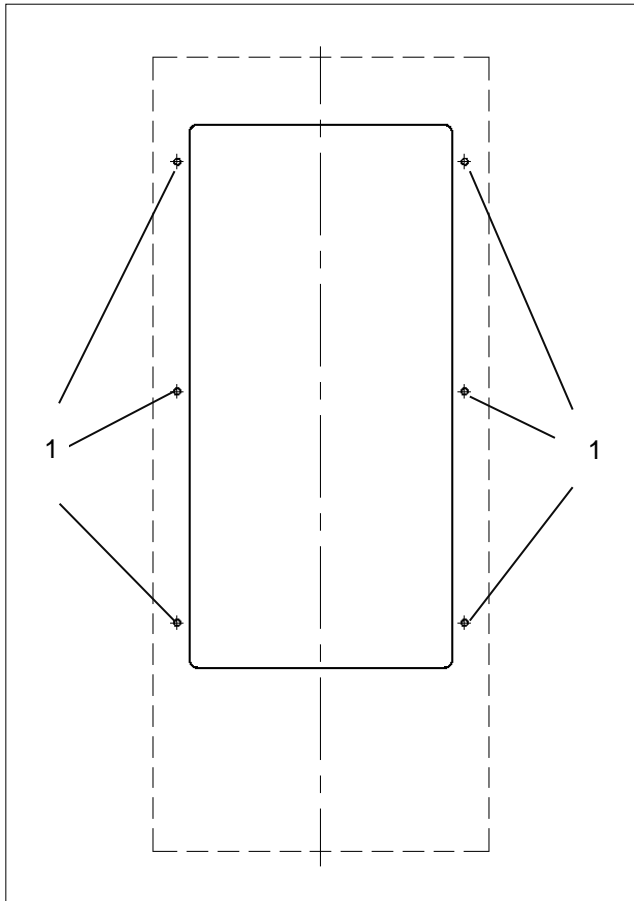

Figure 9 - Switch cabinet exterior view
Holes for DTS cooling unit

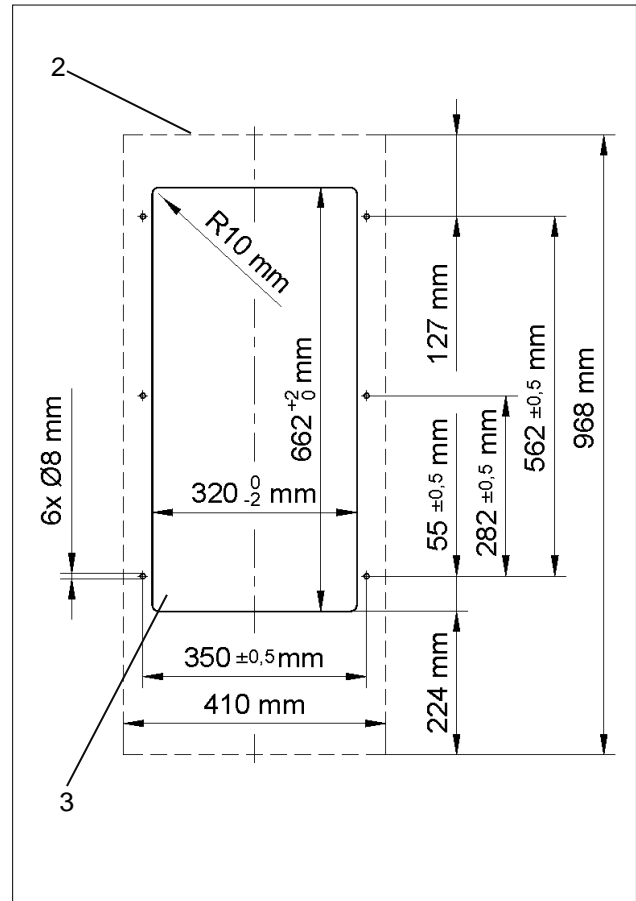

Figure 10 - Switch cabinet exterior view
Cut-out for DTS cooling unit

Item	Designation	Item	Designation
1	Holes	2	Device contour
3	Cut-out		

Make cut-out for the DTS cooling unit

Requirements

- All general requirements have been fulfilled; see [General assembly requirements](#)
- The unit is de-energized.

Required tools and material

- Saw
- Use a switch cabinet cutter, if applicable
- Protective covers

Procedure

- Use a protective cover to protect the switch cabinet from chips.
- Provide the switch cabinet with cut-out (3) and holes (1). For the prescribed dimensions, refer to the figure exterior view of the switch cabinet.
- Deburr the cut edges.
- Remove chips and assembly waste from the switch cabinet.

⇒ *Cut-out and holes have been made.*

Install profile seal on the DTS cooling unit (side attachment)

WARNING

Danger of accidents due to incorrectly installed seals

Leaky seals can allow moisture to penetrate and cause short-circuits.

- Install the seal so that it provides a tight seal to the switch cabinet.
- Always inspect seals during cleaning and maintenance.

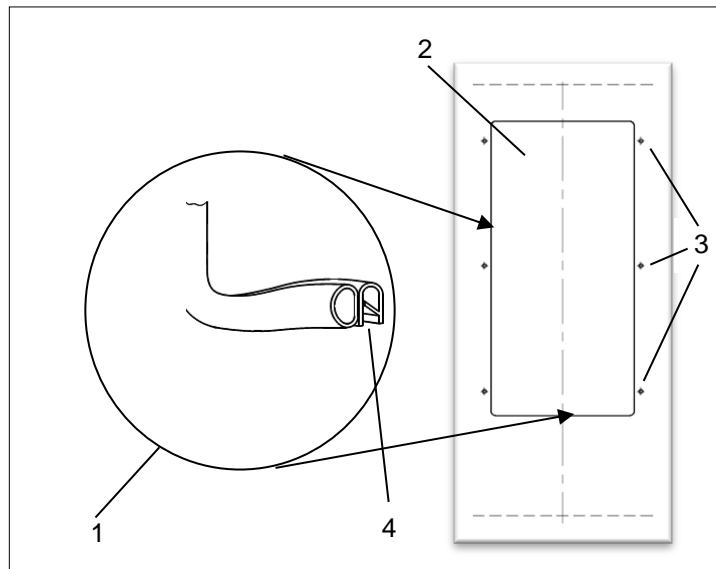

**Figure 11 – Install profile seal
DTS cooling unit (side attachment)**

Item	Designation	Item	Designation
1	Profile seal	2	Cut-out for seals
3	Switch cabinet interior fastenings	4	Profile seal slotted ends

Install profile seals and assemble

Requirements

- Cut-out for the DTS cooling unit have been made; see figure [DTS cooling unit assembly](#)_(side attachment).
- The cooling unit is de-energized.

Required tools and material

- Profile seal (1)
- Installation tool
- Accessory kit: Threaded bolts, screws, nuts, washers

Procedure

- Insert profile seals (1) on the sheet metal edge of the cut-outs (2). Fit the seals with the slotted ends (4) down.
- Screw in the two supplied threaded bolts (accessory kit) in the upper fastening points of the DTS cooling unit. Suspend the cooling unit on the switch cabinet with the threaded bolts installed from outside. Tighten the screws on the DTS cooling unit on the switch cabinet interior (3). Use the supplied screws, nuts and washers (accessory kit) to fasten the unit. Firmly tighten the screw fasteners so that the profile seal is pressed together to a thickness of 2 mm.

⇒ The DTS cooling unit is attached to the switch cabinet and ready for electrical connection; see [Electrical connection](#).

3.4.4 DTI cooling unit assembly (installation)

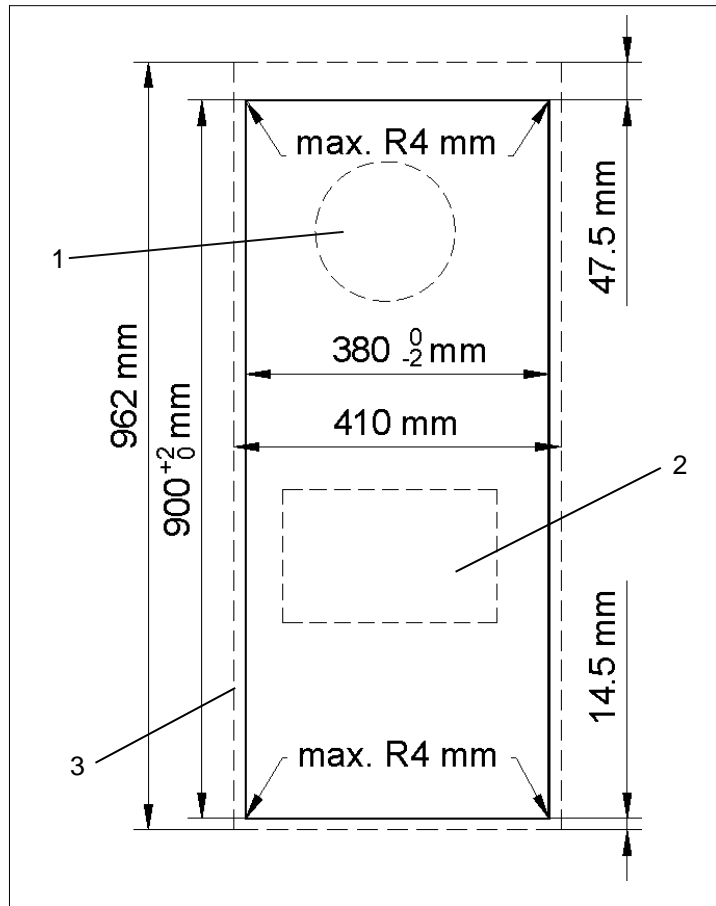

Figure 12 - Switch cabinet exterior view
DTI cooling unit cut-outs

Item	Designation	Item	Designation
1	Air inlet	2	Air outlet
3	Device contour		

Make cut-outs for the DTI cooling unit

Requirements

- All general requirements have been fulfilled; see [General assembly requirements](#)
- The unit is de-energized.

Required tools and material

- Saw
- Use a switch cabinet cutter, if applicable
- Protective covers

Procedure

- Use a protective cover to protect the switch cabinet from chips.
- Provide the switch cabinet with cut-outs. For the prescribed dimensions, refer to the figure switch cabinet exterior view.
- The four corner cut-outs can be rectangular or have a maximum R = 4 mm.
- Deburr the cut edges.
- Remove chips and assembly waste from the switch cabinet.

⇒ *Cut-outs have been made.*

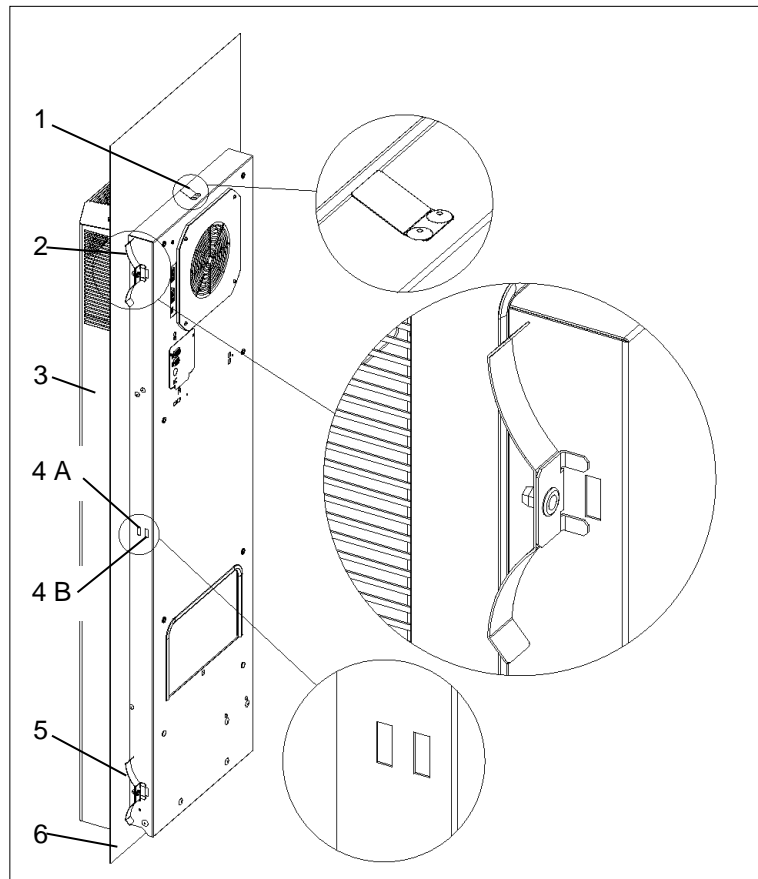
DTI cooling unit switch cabinet assembly (installation)

Figure13 – DTI cooling unit assembly

Item	Designation	Item	Designation
1	Catch spring	2	Fastening spring (top)
3	DTI cooling unit	4 A	Housing - cut-out
4 B	Housing - cut-out	5	Fastening spring (bottom)
6	Switch cabinet wall / switch cabinet door		

☒ The film for DTI cooling units with assembly instructions is available [HERE](#).

Switch cabinet assembly
Requirements

- The cut-out for the DTI cooling unit has been made; see the figure [DTI cooling unit assembly](#).
- The cooling unit is de-energized.

Required tools and material

- Assembly tool, fastening springs (2)/(5) (accessory kit)

Procedure

- Fit the cooling unit (3) in the cut-out from outside; see the figure DTI cooling unit assembly.
- Push the cooling unit (3) into the switch cabinet (6) until the unit seal is applied.
- The catch spring (1) on the top side of the unit audibly engages. The cooling unit (3) is now secured from falling out.
- Engage the fastening springs (2)/(5) on the inside of the switch cabinet (6).
- Press the fastening springs in with your hand so that the retaining bracket engages in the housing cutout (4 A).
- Use the fastening springs in the rear housing cut-outs (4B) for switch cabinets with reinforcement frame.
- Mount the cooling unit (3) so that the emergency condensate drain is arranged at the bottom of the unit.

⇒ The DTI cooling unit is attached to the switch cabinet and ready for [Electrical connection](#).

3.5 Electrical connection
3.5.1 Multi-Controller (MC) electrical circuit diagram



Life-threatening danger due to electric shock

Live units and exposed connection cables can generate an electric shock and cause severe accidents.

- Work on electrical connections must be carried out exclusively by trained, qualified electricians.
- Ensure that the unit is voltage-free before routing all electrical connections.

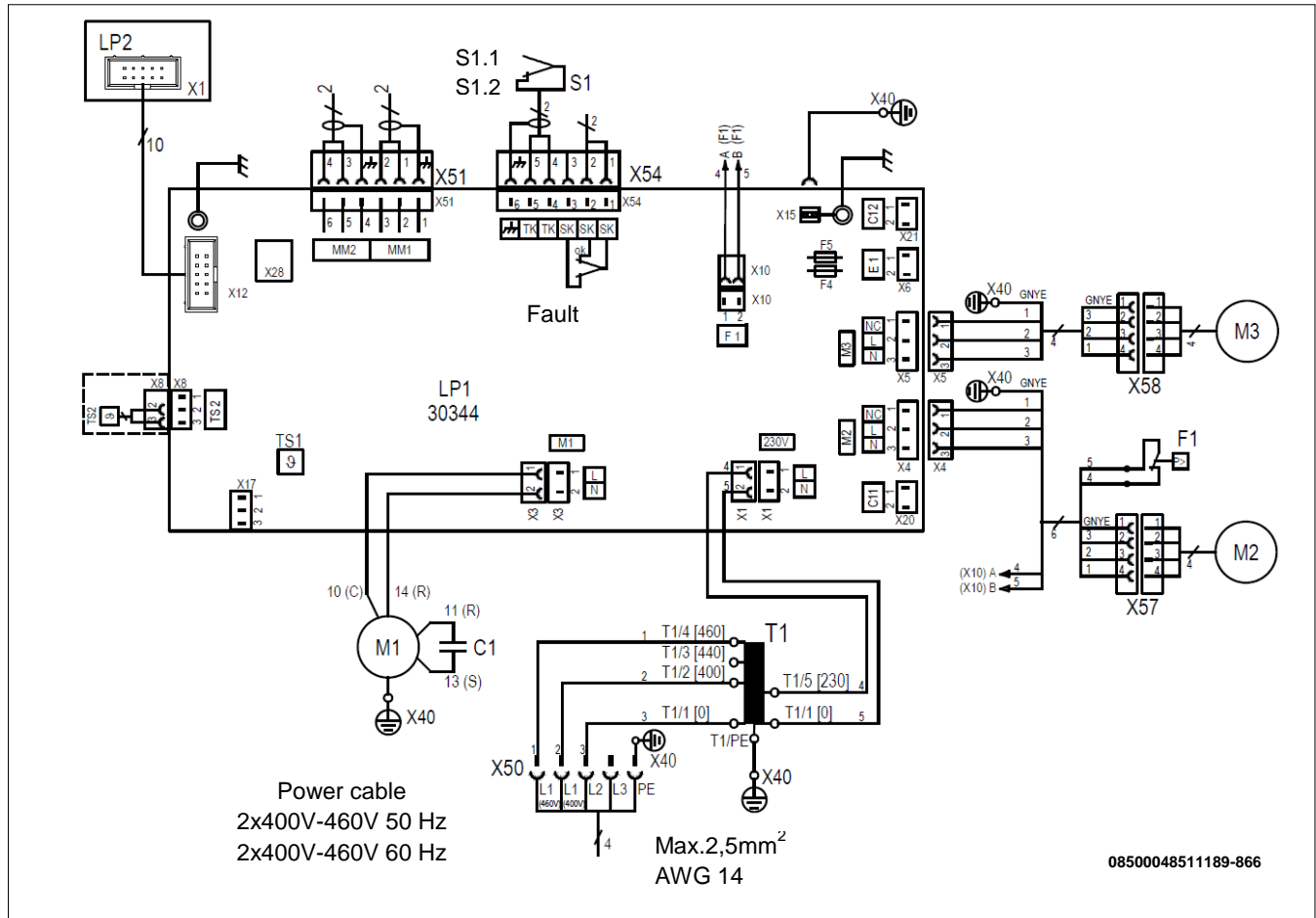

Item	Designation	Item	Designation	Item	Designation
C1	Starting capacitor	F1	High-pressure pressostat	F4-F5	Fuse
LP1	Controller	LP2	Display control unit (MC)	M1	Compressor
M2	Condenser fan (external)	M3	Evaporator fan (internal)	MM1	Multimaster/ input
MM2	Multimaster/ output	S1	Door contact	S1.1	Door open
S1.2	Door close	SK	Fault signal contact (1,2)	TK	Door contact/ signal (4,5)
T1	Transformer	TS1	Temperature sensor (internal)	TS2	Temperature sensor (external)
X28	Service interface (TTL)	X40	Ground terminal contact	X50	Mains terminal contact
X51	Multimaster terminal contact	X54	Door contact+ terminal contact +Fault indication	[]	Optional

3.5.2 Multimaster connection

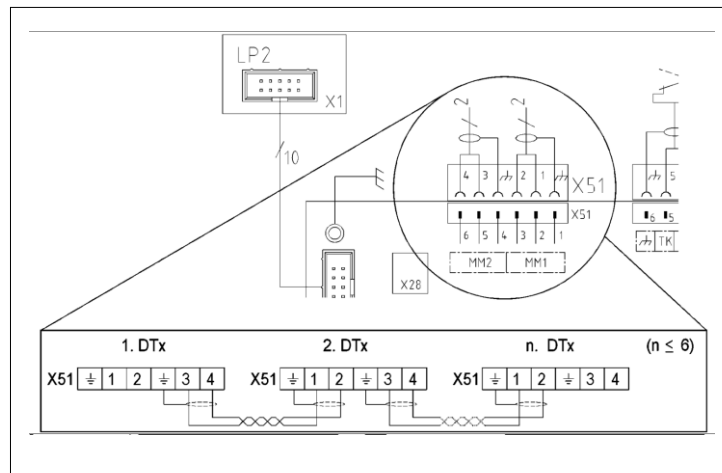

Figure 14 – Multimaster control

- The Multimaster function can control up to six connected cooling units (bus functions). The connection takes place on the input and output side via two contacts MM1 and MM2. The contacts are supplied with low voltage (<20V, 20mA) from the cooling unit.
- ☒ A shielded cable with twisted pairs is used to prevent interference.
- If shielded cables are not used, ensure that there are no sources of interference in the immediate vicinity. Sources of interference include: Supply lines and components with elevated electromagnetic radiation.

3.5.3 Door contact switch



WARNING

Danger due to connection of external voltage at the input of the door contact

External voltage can cause severe accidents.

- Connection of external voltage to the input for the door cabinet is prohibited.
- The input/door contact provides low voltage (< 20V, 20mA) for the door contact switch.

Installation of a door contact switch increases safety and prevents increased accumulation of condensate.

- ☒ If a door contact switch has not been connected, the connection contact (S1) must always be bypassed.

Door contact switch installation

Requirements

- The cooling unit is de-energized.

Procedure

- The door contact switch is connected to the S1 connection; see [Electrical connection](#) or the electrical circuit diagram in the housing cover.
- The door contact is supplied with low voltage, <20V, 20 mA, from the cooling unit.
- Connect the shielding to the terminal for functional earth on one end.
- A shielded cable with twisted pairs is used to prevent interference.
- If shielded cables are not used, ensure that there are no sources of interference in the immediate vicinity. Sources of interference include supply cables and components with increased electromagnetic radiation, including frequency converters, motor drives, etc.

⇒ The door contact switch is connected. The motors switch off when the switch cabinet is opened.

3.5.4 Mains supply connection



Potential danger due to incorrect cables

An incorrect cable cross-section will cause the cable to overheat. Scorched insulation can cause fires.

- The cable cross-section (4) matches the output required for the power consumption and is 0.5 – 2.5mm² or AWG 20 to AWG 14.

The following general requirements must be ensured for safe and reliable operation of the cooling units:

- Upstream installation of a supply-side temperature regulator is prohibited.
 - Connect the upstream fuse specified on the type plate as wiring protection; see [Type plate](#) and [Adapting the upstream fuse](#).
 - Ensure that the type plate specifications for rated values match the present values for mains voltage and mains frequency; see [Type plate](#).
 - Always connect the cooling unit to the mains by means of a separating device (switch/contacter).
- ☒ The separating device must have a contact opening of 3 mm. The separating device is installed by the customer.

Cooling unit electrical connection

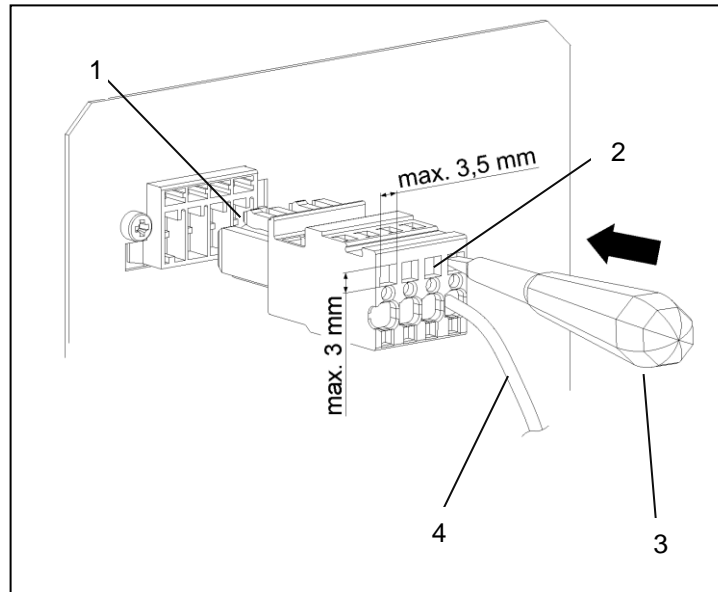

Figure 15 - Cooling unit plug connection

Item	Designation	Item	Designation
1	Connecting plug	2	Cage terminal - max. 3.5 x 3.0 mm
3	Screwdriver (slotted)	4	Cable - \varnothing 0.5 – 2.5mm ²

Requirement

- All general requirements for safe and reliable operation are assured; see [Mains supply connection](#)
- The cooling unit is de-energized.

Procedure

- Connect the cable (4) with the connecting plug (1)/(accessory kit) as specified in the electrical circuit diagram; see [Electrical connection](#).
 - For electrical connection, insert the screwdriver (3) into the cage terminal (2) and connect the cables (4) to the cooling unit with the connecting plug (1).
 - ☒ Insert the screwdriver firmly into the cage terminal (2). Never twist the screwdriver; otherwise the cage terminal (2) will be damaged.
 - Before switching on, ensure that the mains voltage matches the upstream fuse; see [Electrical connection](#).
- ⇒ *The cooling unit is connected electrically.*

3.5.5 Adapting the upstream fuse /transformer options

- ☒ Only cooling units with the rated operating voltage 400V / 460V can be optionally connected to a different mains voltage.
- Reconnection takes place via the supply of the primary side of the transformer.
- ☒ The upstream fuse must match the changed mains voltage; see Adapting the upstream fuse.

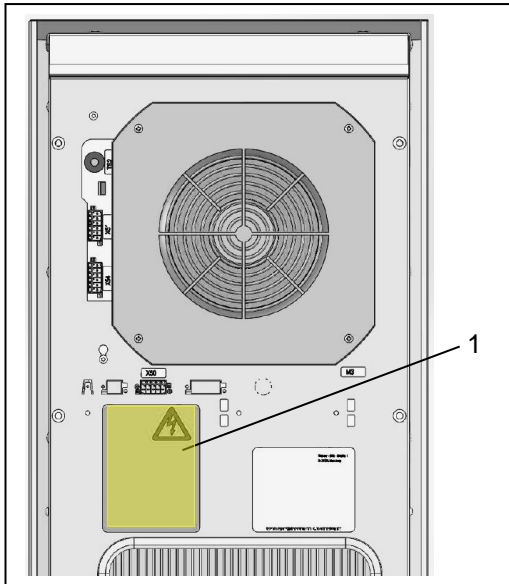

☒ The specifications for the factory settings of the transformer are provided on the yellow connection diagram (1) on the rear side of the unit.

☒ UL-conformity with the following fuses:
 Category "ClassCC", slow-burning.

Figure 16 - Transformer options

Transformer - Option		Pre-fuse (Min. 480 V)
400 V	T1/ 1 [0] – T 1/ 2 [400]	Max. 4 A
440 V	T1/ 1 [0] – T 1/ 3 [440]	Max. 4 A
460 V	T1/ 1 [0] – T 1/ 4 [460]	Max. 4 A

3.5.6 Collective fault signal

- Two connections are provided for connection of the collective fault signal. They are marked with the item designation SK; see [Electrical connection](#).
- The fault signaling contact is potential-free.
- ☒ Ensure that the contact is loaded with a maximum of 230V, 1 A.

4 Operation

4.1 General functions

NOTE

Danger of damage to the cooling unit

Operation without the unit cover prevents the adequate supply of air to the condenser and limits the intended heating function.

- Only operate the cooling unit with the unit cover installed.

The Multi-Controller (MC) has a control panel with a green LED light (1). If an error occurs, the green LED light (1) blinks and various system information is displayed in the LCD (5); see [system information](#).

If assembly and installation are completed, switch on the power supply to the cooling unit.

- The cooling unit starts its operation and the LED light (1) illuminates green continuously.

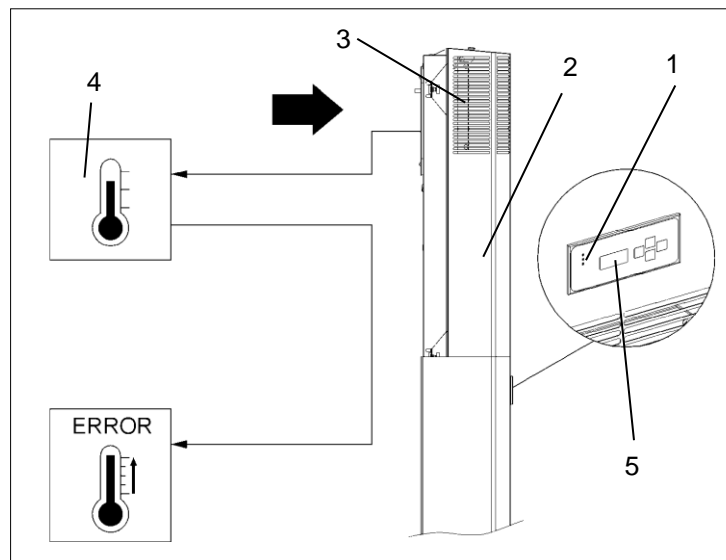

Figure 17 – Electronic control function

- After the supply voltage has been connected and the door is closed, the units run continuously.
- ⊗ Exception: Energy-saving mode and cooling units with anti-freeze option.
- ⊗ The external temperature sensor controls the energy-saving mode; see [TS2 temperature sensor](#).
- The Multimaster function can connect up to six cooling units in the bus function.
- The LCD (5) displays the current operating statuses; see [System information](#).
- The cooling unit (2) is equipped with an electronic control unit. An internal temperature sensor (4) detects the temperature of the air sucked in from the interior of the switch cabinet (3). If the upper or lower limit temperature is exceeded or undercut, a fault indication is triggered.
- The green LED light (1) blinks and the LCD (5) displays the error number with temperature (°C/°F).
- ⊗ The ambient conditions and switch cabinet interior temperatures must correspond to the prescribed technical data; see [Technical data](#).
- ⊗ The ambient temperature must be less than 55°C; see [Air flow functional principle](#).

4.2 Multi-Controller operation

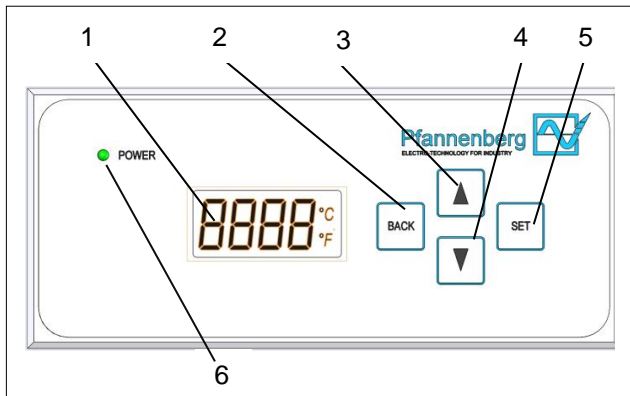

Figure 18 - Control panel (MC)

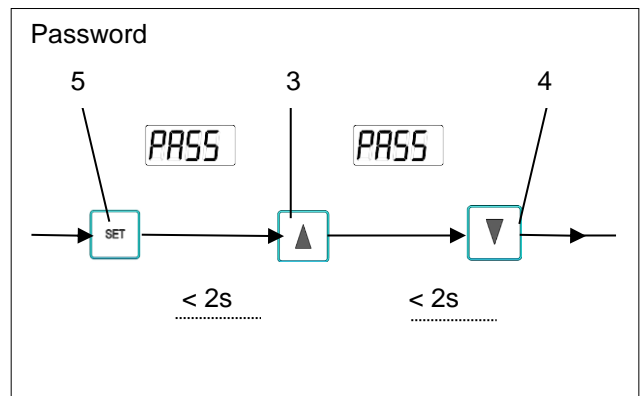

Figure 19 - Password button combination (MC)

The control panel has four menu settings that are displayed on the LCD (1).

LCD	Menu setting	Input
SEEP °C / °F	SetP: Switch cabinet temperature setpoint	0 – 90 °C
Lit ⁺ °C / °F	Lit ⁺ : Maximum switch cabinet temperature value (high limit value)	- 55 – 95 °C
Lit ₋ °C / °F	Lit ₋ : Minimum switch cabinet temperature value (low limit value)	- 55 – 95 °C
Unit °C / °F	Unit: Unit of the switch cabinet temperature	°C / °F

4.3 Carrying out menu settings

Requirement

- Cooling unit has started operation.
- LED light (6) of the control panel illuminates green.

Procedure

- Scroll through the menus (SetP, Lit⁺, Lit₋, Unit) from the temperature display (1) with the SCROLL UP (3) and SCROLL DOWN (4) buttons.
- Select a menu with the SET button (5).
- Enter the password. After pressing the SET button (5) press the SCROLL UP (3) and SCROLL DOWN (4) buttons within two seconds; see Password button combination figure.
- Always adjust the desired value with the SCROLL UP (3) and SCROLL DOWN (4) buttons.
- Confirm the value with the SET button (5).
- When the BACK button (2) is pressed, the value is not saved.
- Select a different menu by scrolling with the SCROLL UP (3) and SCROLL DOWN (4) buttons.
- ☒ If there is no input for 30 seconds, a TIMEOUT is initiated and the LCD switches to temperature display.

⇒ Menu is adjusted in the cooling unit.

Menu settings

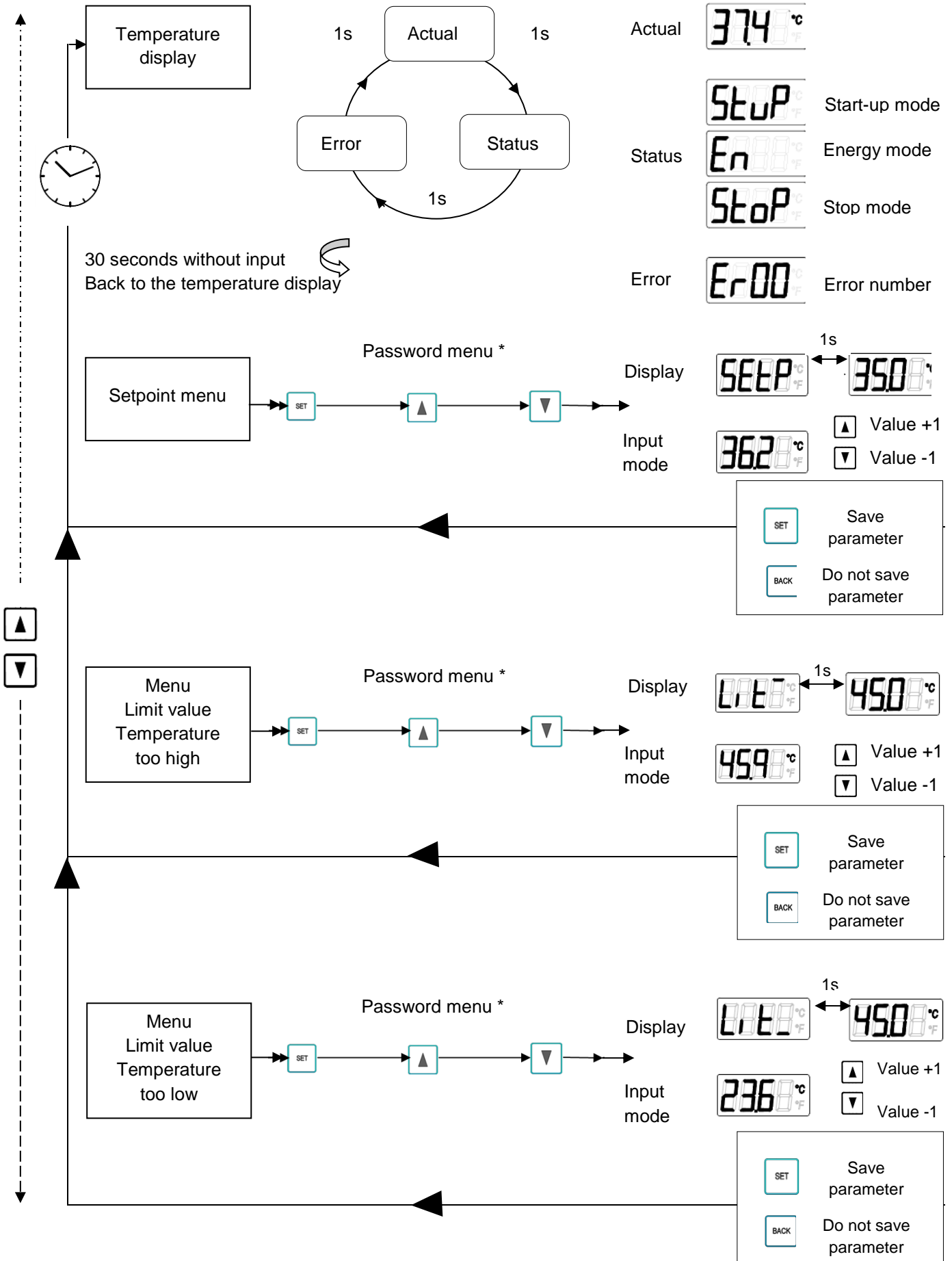

Menu settings

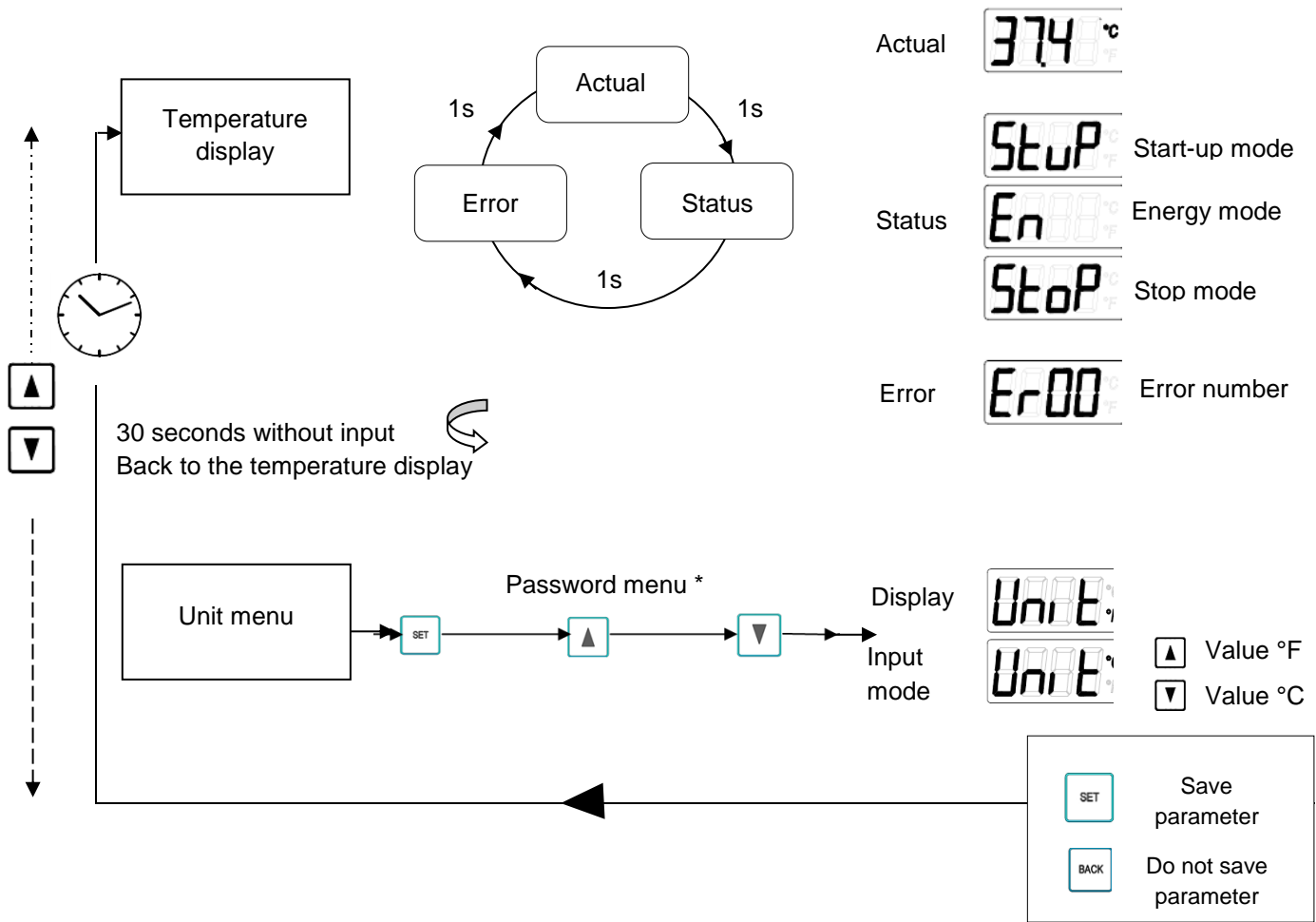

4.4 Operation of the cooling unit

- After connection of the mains voltage, the device switches to startup/test mode or directly to operating mode. The controller equipment determines which mode is activated.
- In operating mode the cooling unit switches to cooling mode as needed. This takes place depending on whether a temperature switching threshold (TSet) is reached or undercut.
- ☒ Cooling mode switches off when the temperature switching threshold (TSet) is undercut. It continues running if the temperature switching threshold (TSet) has not been reached yet.
- ☒ The evaporator fan (internal), condenser fan (external) and compressor switch off when the door is opened.

NOTE

Condensate flowing back into the switch cabinet can damage the electronic components

Internal temperatures below the dewpoint or damaged switch cabinet seals cause excessive accumulation of condensate.

- Regular inspection of the seals assures protection against heavy condensate accumulation.
- Ensure that the accumulating condensate can drain freely.

Operating conditions

- The mains voltage must lie within the specified range; see [Electrical data](#).
- ☒ A deviation of $\pm 10\%$ is permissible.
- The rated frequency must be within ± 3 Hz of the value specified.
- The ambient temperature must be below $55\text{ }^{\circ}\text{C}$. For further options, see [Technical data](#).
- ☒ The cooling unit must only be used in such a manner as to ensure that the specified cooling capacity is able to meet actual demands.
- ☒ Only the specified coolant may be used.

NOTE

Spare parts from third-party manufacturers can damage the unit

Internal temperatures below the dewpoint or damaged switch cabinet seals cause excessive accumulation of condensate.

- Only use specially harmonized manufacturer parts for safe and reliable operation.

- ☒ For Pfannenber spare part numbers, see [Spare part orders](#).

4.5 Service interface

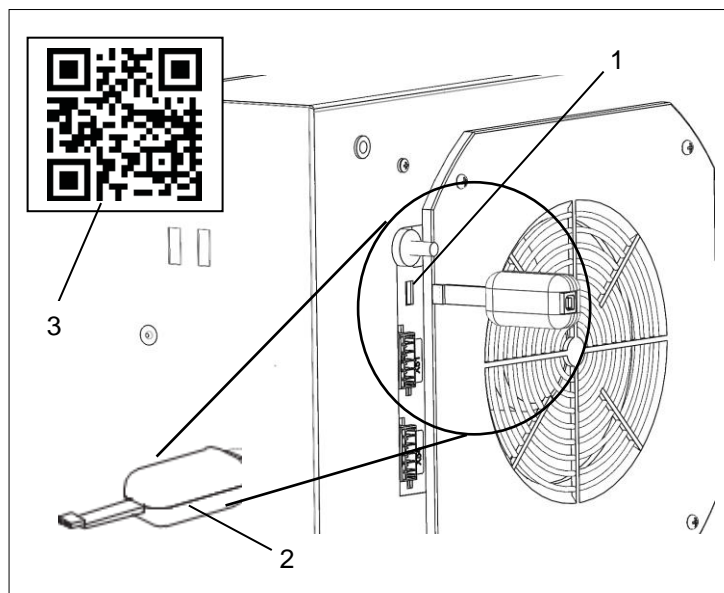

Figure 20 - Service

- The service interface (1) can be used to change operating parameters.
 - For this purpose, a USB adapter (2) and the ECoolPLANT 2.X configuration software and USB driver software are required.
 - The connection for the USB adapter is marked on the electrical circuit diagram with the identifier X28.
 - The USB adapter enables connection to a computer that works with the ECoolPLANT 2.X configuration software. The detailed use is described in the corresponding operating manual for the ECoolPLANT 2.X software.
 - Remove the USB adapter (2) from the unit after use. The service interface (1) is only provided for temporary data exchange in order to read system notifications, etc. Continuous operation is prohibited.
- ☒ The USB adapter is available as an accessory, see [Spare part orders](#).
 - ☒ The ECoolPLANT software (3) is available for download free of charge on the website: <https://www.pfannenber.com/> QR-Code (3).
 - ☒ The corresponding operating manual for the ECoolPLANT software is available [HERE](#) and from My Pfannenber.

4.6 Error messages

The error numbers are not displayed for units with standard controllers: With the ECoolPLANT software error numbers can be read on the computer.

☒ The blinking of the red LED light on the controller circuit board is **not** a fault indicator or error message. The red LED light indicates that voltage is supplied to the cooling unit.

Error no.	Fault	Unit activity	Possible causes	Corrective measures
Er00	<ul style="list-style-type: none"> • LED: • Compressor: • Evaporator fan (internal): • Condenser fan (external): • Heater (external): • Fault signal contact: 	Blinking OFF OFF OFF OFF Closed	<ul style="list-style-type: none"> • Door contact: • The door contact loop has been interrupted. 	<ul style="list-style-type: none"> ▪ Close door. ▪ Connect door contact switch. ▪ Bypass door contact. ▪ Check wiring.
Er01	<ul style="list-style-type: none"> • LED: • Compressor: • Evaporator fan (internal): • Condenser fan (external): • Heater (external): • Fault signal contact: 	Blinking OFF ON ON OFF Open	<ul style="list-style-type: none"> • Pressostat tripped: • Excessively high pressure has built up in the refrigerant circuit. The cooling unit cannot dissipate the heat from the refrigerant circuit. 	<ul style="list-style-type: none"> ▪ Allow the unit to cool down. ▪ Clean the heat exchanger fins (internal/external). ▪ Check condenser fan (external) for function.
Er04	<ul style="list-style-type: none"> • LED: • Compressor: • Evaporator fan (internal): • Condenser fan (external): • Heater (external): • Fault signal contact: 	Blinking OFF OFF OFF OFF Open	<ul style="list-style-type: none"> • Phase sequence / phase loss: • Failure of at least one phase or phase sequence is incorrect (only with alternating current units with rotating piston compressors). 	<ul style="list-style-type: none"> ▪ Check the field of rotation - (clockwise rotation is required). ▪ All phases must carry rated operational voltage.
Er05	<ul style="list-style-type: none"> • LED: • Compressor: • Evaporator fan (internal): • Condenser fan (external): • External heating: • Fault signal contact: 	Blinking ON ON ON OFF Open	<ul style="list-style-type: none"> • Sensor 1 (TS1) defective. 	<ul style="list-style-type: none"> ▪ Replace Sensor 1 or the controller circuit board according to the unit type. ▪ Replace controller circuit board if the sensor is soldered in place.



Error messages

Error no.	Fault	Unit activity	Possible causes	Corrective measures
Er06	<ul style="list-style-type: none"> • LED: • Compressor: • Evaporator fan (internal): • Condenser fan (external): • Heater (external): • Fault signal contact: 	Blinking OFF ON ON OFF Open	<ul style="list-style-type: none"> • Sensor 1 Minimum: • Minimum switch cabinet temperature value "Lit_" (LCD) is reached or exceeded. 	<ul style="list-style-type: none"> ▪ Select higher switch cabinet temperature setpoint. ▪ Inspect the switch cabinet for leaks. ▪ Move components near the air inlet and outlet further away in order to prevent an air short circuit. (Cold air is diverted directly to the air inlet by components.)
Er07	<ul style="list-style-type: none"> • LED: • Compressor: • Evaporator fan (internal): • Condenser fan (external): • Heater (external): • Fault signal contact: 	Blinking ON ON ON OFF Open	<ul style="list-style-type: none"> • Sensor 1 Maximum: • The maximum value of the switch cabinet temperature "Lit_" (LCD) has been reached or exceeded. • The cooling unit cannot sufficiently cool the air in the switch cabinet. 	<ul style="list-style-type: none"> ▪ Check the settings of the cooling unit. ▪ Clean the heat exchanger fins (internal/external). ▪ Check evaporator fan (internally) for functionality. ▪ Check the refrigeration circuit for escaping refrigerant or leaks. ▪ If necessary, install a cooling unit with a higher cooling capacity.
Er08	<ul style="list-style-type: none"> • LED: • Compressor: • Evaporator fan (internal): • Condenser fan (external): • Heater (external): • Fault signal contact: 	Blinking ON ON ON OFF Open	<ul style="list-style-type: none"> • Sensor 2 (TS2) defective. 	<ul style="list-style-type: none"> ▪ Replace Sensor 2 or the controller circuit board according to the unit type. ▪ Sensor 2 is plugged into the circuit board, not permanently soldered in place.

Error messages

Error no.	Fault	Unit activity	Possible causes	Corrective measures
Er15	<ul style="list-style-type: none"> • LED: • Compressor: • Evaporator fan (internal): • Condenser fan (external): • Heater (external): • Fault signal contact: 	<p>Blinking</p> <p>OFF</p> <p>OFF</p> <p>OFF</p> <p>OFF</p> <p>Open</p>	<ul style="list-style-type: none"> • Anti-freeze (optional): • Anti-freeze sensor $\leq 1^{\circ}\text{C}$. • Safety shut-off, because there is a risk of icing of the compressor. 	<ul style="list-style-type: none"> ▪ Restart after accumulating condensate water has evaporated. ☒ A restart is only possible with disconnection and re-connection of the mains voltage. ▪ For safety reasons, there is no other means of resetting. ▪ Clean the heat exchanger fins (internal/external). Inspect the switch cabinet for leaks. ▪ Select higher switch cabinet temperature setpoint. ▪ Check function of the evaporator fan (internal).
Er19	<ul style="list-style-type: none"> • LED: • Compressor: • Evaporator fan (internal): • Condenser fan (external): • Heater (external): • Fault signal contact: 	<p>Blinking</p> <p>OFF</p> <p>OFF</p> <p>OFF</p> <p>OFF</p> <p>Open</p>	<ul style="list-style-type: none"> • Sensor 5 (TS5) defective 	<ul style="list-style-type: none"> ▪ Replace Sensor 5 or the controller circuit board according to the unit type.

4.7 LCD error messages

Error no.	Control panel	Unit activity	System information
	<ul style="list-style-type: none"> • LED: • Compressor: • Evaporator fan (internal): • Condenser fan (external): • Heater (external): • Fault signal contact: 	Illuminated OFF OFF OFF OFF Closed	Energy saving mode: <ul style="list-style-type: none"> - Energy function execution, activated in energy saving mode. - For detailed information about energy saving mode, see Energy-saving mode.
	<ul style="list-style-type: none"> • LED: • Compressor: • Evaporator fan (internal): • Condenser fan (external): • Heater (external): • Fault signal contact: 	Illuminated OFF OFF OFF OFF Closed	Start-up mode <ul style="list-style-type: none"> - The cooling unit starts its operation
	<ul style="list-style-type: none"> • LED: • Compressor: • Evaporator fan (internal): • Condenser fan (external): • Heater (external): • Fault signal contact: 	Illuminated OFF OFF OFF OFF Closed	Stop mode execution. The unit was stopped due to: <ul style="list-style-type: none"> - Opening of the switch cabinet door. - The cooling unit received a stop command, e.g. via the software application.

5 Service and Maintenance

5.1 General cleaning



DANGER

Life-threatening danger due to electric shock

Live units and exposed connection cables can generate an electric shock and cause severe accidents.

- Work on electrical connections must be carried out exclusively by trained, qualified electricians.
- Before working on the unit, de-energize all supply lines to the separate fuse or a main switch, disconnect the system and secure to prevent re-connection.
- Test to ensure the absence of voltage on the unit.



WARNING

Danger of accidents due to component damage during cleaning

Cleaning of cooling units with water jet, steam jet, high-pressure washer or sharp objects can damage the electrical and electronic assemblies. Malfunctions can cause accidents.

- Do not clean with a water jet, pressure washer or flammable cleaning agents.
- Protect electrical components from the penetration of moisture.
- Do not use pointed or sharp-edged objects to clean the fins. They must not be pinched or damaged.



CAUTION

Danger of crushing during removal of the unit cover

Hands and other body parts can be crushed during removal and re-installation of the unit cover.

- Keep body parts out of the space between the frame, springs and unit cut-out.
- Work carefully and wear gloves.

The frequency of cleaning intervals depends on the operating conditions in the individual case. The following cleaning work must take place regularly for safe and reliable operation of the cooling units:

- Remove dust or environmental residue from the heat exchangers.
- Check the condensate drain regularly.

5.2 Cleaning the cooling unit - Unit cover removal

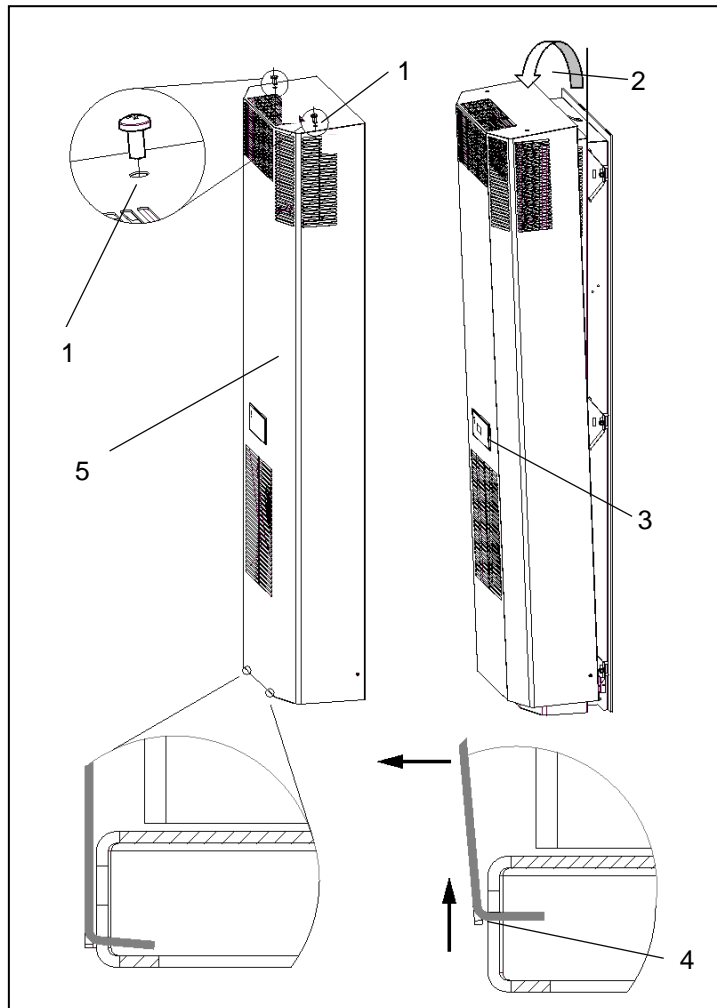

Figure 21 – Unit cover removal

Item	Designation	Item	Designation	Item	Designation
1	Fastening screws	2	Tilting angle 20°	3	Display or operating unit
4	Bottom plate slot	5	Unit cover		

Requirement

- The cooling unit is de-energized

Procedure

- Remove the fastening screws (1).
- Tilt the unit cover (5) forward 20° (2).
- Disconnect the earthing cable and connecting cables from the display or operating unit (inside) (3).
- Raise the unit cover about 15 mm and pull it out of the slots in the bottom plate (4).

⇒ *The unit cover is removed.*

5.3 Cooling unit and filter mat cleaning tasks

NOTE

Danger of damage to the filter mat due to improper cleaning

- Do not wring out the filter mat.
- Avoid water jets with high pressure.
- Immediately replace filter mats that are contaminated with oil or grease.

Requirements

- The cooling unit is de-energized.
- The unit cover is removed.

⊗ Time intervals for the cleaning or replacement of filter mats depend heavily on the ambient air contamination.

Required tools and material

- Brush
- Water below 40 °C
- Mild detergent
- Vacuum or compressed air cleaner

Procedure

- Clean the heat exchangers using a soft brush or compressed air.
- If the cooling units have a pre-filter, the filter mat must be cleaned at regular intervals.
- Wash the filter mat with water at a temperature of up to 40 °C and commercially available mild detergent.
- If the dirt is dry, vacuum, blow or knock the dirt off of the filter mat.
- Ensure that correct and safe operation is assured after cleaning.

⇒ *The cooling unit is clean.*

5.4 Maintenance



DANGER

Life-threatening danger due to electric shock

Live units and exposed connection cables can generate an electric shock and cause severe accidents.

- Opening, troubleshooting and replacement of components on the unit must only be carried out by qualified personnel.
- Always ensure that the unit is de-energized before working on the unit.



WARNING

Danger due to improper maintenance work

Damage of components and faulty replacement of components can cause accidents.

- Always switch off the disconnecter/contactator before beginning maintenance work.
- Ensure that the fans are in idle position and are no longer rotating.
- After replacement of defective parts or components, inspect the unit for correct and safe operation.
- After all maintenance or replacement of spare parts, check to ensure the full capability of the condensate drain.



WARNING

Spare parts from third-party manufacturers can damage the unit and cause accidents.

- Only original parts are subject to the manufacturer's quality control.
- Only use specially agreed manufacturer parts for safe and reliable operation.

NOTE

Danger of unit damage due to incorrectly performed maintenance

Disregard of the recommended maintenance work reduces the cooling capacity of the cooling unit and could result in reduced machine availability.

- Maintenance work must be carried out regularly, as specified in the maintenance checklist.
- Warranty claims are only valid for units that have been maintained according to specifications.

The refrigerant circuit is a maintenance-free, hermetically sealed system. The following preparations are made at the factory:

- Necessary refrigerant quantities are filled.
- All cooling units are tested for leakage in the factory in accordance with DGUV-R 100-500, 2.35 (operation of refrigeration plants, heat pumps and cooling equipment).
- A functional test run was carried out.

Pfannenberg recommendation to the operator for maintenance work:

- Carry out maintenance work regularly, every 12 months, according to the maintenance checklist; see [Maintenance checklist template](#).
- Shorter maintenance intervals are required for cooling units that cool in oil- and dust-laden ambient air. A reduced guideline value of two to six months between maintenance intervals applies.
- ☒ The functions of Pfannenberg filters are optimally matched to the cooling units. Therefore, use of Pfannenberg filters has a positive effect on the scope of maintenance work.

5.5 Maintenance checklist template

Cooling unit maintenance checklist				
<p>Maintenance interval: Conduct maintenance every twelve months. Conduct maintenance every two to six months in oil- and dust-laden environmental air.</p> <p>Type: Serial number: Date of maintenance: Technician carrying out the work (name):</p>				
	Unit range designation/ Required maintenance tasks	Visual inspection	To Do	Result
1	Aggregate before maintenance			
1.1	General visual inspection of the aggregate			
1.2	Inspection for corrosion damage			
2	Cooling circuit			
2.1	Inspect refrigerant-carrying parts for traces of oil			
2.2	Inspect refrigerant-carrying parts for leak tightness			
2.3	Inspect electrical connections for damage			
2.4	Inspect evaporator for ice formation			
3	Condenser / heat exchanger			
3.1	Inspect pipe package for deposits			
3.2	Inspection for general corrosion damage			
3.3	Inspect, clean, align fins*			
4	Evaporator / heat exchanger			
4.1	Inspect pipe package for deposits			
4.2	Inspection for general corrosion damage			
4.3	Inspect, clean, align fins*			
5	Condenser fan (external)			
5.1	Inspect mount for loose parts			
5.2	Inspect the electrical connection for damage			
5.3	Check motor bearings for noises			
5.4	Check the drive for signs of overheating			
5.5	Clean fans*			
6	Evaporator fan (internal)			
6.1	Inspect mount for loose parts			
6.2	Inspect the electrical connection for damage			
6.3	Check motor bearings for noises			
6.4	Check the drive for signs of overheating			
6.5	Clean fans*			
7	Pre-filter			
7.1	Replace filter mat*			
7.2	Clean filter mat*			

* Maintenance intervals are more frequent, depending on the degree of contamination.

5.6 Decommissioning

WARNING

Danger of injury due to materials and substances

Improper work on the unit or opening of the refrigerant circuit can be damaging to health.

- Always ensure that the unit is de-energized before working on the unit.
- The unit must only be disposed of by qualified personnel and in accordance with applicable environmental regulations.

If the cooling unit is no longer needed for a longer period, it must be disconnected from the voltage supply.

☒ Ensure that improper start-up by third parties is not possible.

Final decommissioning

CAUTION

Danger of crushing during the decommissioning of units

Hands and other body parts can be crushed during removal of units.

- Keep body parts out of the space between the frame, springs and unit cut-out.

If cooling units are to be definitively decommissioned or disposed of, the following must be observed:

- Applicable statutory regulations of the user country and environmental protection regulations must be observed.
- Refrigerant must be professionally extracted from the refrigerant system. Avoid refrigerant emissions.
- The cooling unit must only be disposed of by authorized, qualified personnel.

☒ Waste equipment must also be disposed of correctly by Pfannenberg. Freight charges for delivery to one of our manufacturing facilities must be pre-paid.

6 Troubleshooting

Fault	Possible causes	Corrective measures
Unit does not cool; Evaporator fan (internal) running	<ul style="list-style-type: none"> • Temperature setting too high. 	<ul style="list-style-type: none"> ▪ Check the temperature setting.
Unit does not cool sufficiently	<ul style="list-style-type: none"> • Operating limits exceeded. 	<ul style="list-style-type: none"> ▪ Check the ambient temperature and internal load.
	<ul style="list-style-type: none"> • Too little coolant. 	<ul style="list-style-type: none"> ▪ Call in authorized qualified personnel; check the unit for leakage.
	<ul style="list-style-type: none"> • Heat exchanger dirty. 	<ul style="list-style-type: none"> ▪ Clean the heat exchanger.
	<ul style="list-style-type: none"> • Evaporator fan (internal) defective. • Condenser fan (external) defective. 	<ul style="list-style-type: none"> ▪ Call in authorized, qualified personnel; replace fan.
	<ul style="list-style-type: none"> • Disruption in the air circulation inside the cabinet. 	<ul style="list-style-type: none"> ▪ Check the installation and the path of air circulating in the switch cabinet. ▪ Check the supply and outlet flow of air of the cooling unit to the inlet and outlet opening of the switch cabinet.
Unit cools only periodically	<ul style="list-style-type: none"> • Temperature set incorrectly or unit is defective. 	<ul style="list-style-type: none"> ▪ Set the a higher temperature. ▪ Call in authorized qualified personnel, check the unit.
Condensate accumulates in the switch cabinet	<ul style="list-style-type: none"> • Exhaust temperature is too low. 	<ul style="list-style-type: none"> ▪ Close the cabinet door.
	<ul style="list-style-type: none"> • Switch cabinet is not sufficiently sealed. 	<ul style="list-style-type: none"> ▪ Correct leaky points or seals on the switch cabinet. ▪ Check the temperature setting.
Condensate does not drain	<ul style="list-style-type: none"> • Condensate drain is plugged up. 	<ul style="list-style-type: none"> ▪ Clean the condensate drain. ▪ Check whether the condensate drain hose is free from kinks and is installed with a downward slope.
Condensate drains from the unit	<ul style="list-style-type: none"> • Condensate evaporator is defective or too much condensate accumulates. 	<ul style="list-style-type: none"> ▪ Replace fuses for the condensate evaporator.
	<ul style="list-style-type: none"> • Switch cabinet is not sufficiently sealed. 	<ul style="list-style-type: none"> ▪ Correct leaky points or seals on the switch cabinet.

☒ The blinking of the red LED light on the controller circuit board is not a fault indicator or error message. The red LED lamp indicates that voltage is supplied to the cooling unit.

7 Spare part orders / accessory orders

No.	Designation	No.	Designation
18811100065	Evaporator fan (internal)	18811100065	Condenser fan (external)
18810200144	Unit cover DTI 62/6301C RAL	18810200145	Unit cover DTS 62/6301C RAL
18810000058	Multi-Controller (MC) control panel	18810000001	Standard controller (SC) display unit
18314000100	Condensate collecting bottle	18310000004	USB adapter
18310000151	Filter adapter	18300000147	Fleece filter
18300000148	Fluted filter	18300000149	Metal filter

- ☒ Always specify the Pfannenberg part numbers when ordering spare parts and accessory parts.
- ☒ The Pfannenberg part numbers for the controller are provided on the transformer of the controller.

8 Terms of warranty

The warranty does not apply or is voided in the following cases:

- Improper use of the unit.
- Failure to observe operating conditions or disregard of the operating manual.
- Lack of regular maintenance on the cooling units.
- Damage due to disregard of maintenance recommendations.
- Damage to cooling units due to soiled or clogged filters.
- Damage due to unauthorized opening of the refrigerant circuit.
- Modifications carried out on the unit or a change to the serial number.
- In the event of damage during transport or other accidents.
- Replacement of parts by unauthorized personnel.

- ☒ Only original Pfannenberg parts are permitted for use. Violations void the warranty.

For recognition of warranty claims and return of the unit, observe the following:

- Provide an exact description of the defect and the SRO (RMA) numbers specified by Pfannenberg with the cooling unit.
- Include a reference document (delivery note or invoice copy).
- Forward the cooling unit to us, complete with all accessories, in the original box or in comparable packaging with freight and transport insurance pre-paid.

Observe transport instructions; see [Transport](#).

Liability disclaimer:

All information contained was thoroughly checked in May 2017.

However, we make no guarantee as to the completeness and correctness of the specifications.

Legal notice:

Pfannenberg GmbH

Werner-Witt-Straße 1

21035 Hamburg

Tel. +49 40 734 12-0

www.pfannenberg.com

© Pfannenberg 2017