

**Betriebsanleitung/ Sicherheitshandbuch
Instruction Manual/ Safety Manual
Instruction de service/ Manuel de sécurité
Istruzioni per l'uso/ Manuale di sicurezza**

Überwacher Schallgeber/ Monitored Sounder
Sirène surveillée/ Sirene controllate

DS5-SIL / DS10-SIL (AC)



Contents

1.	Brief description of the system.....	20
2.	Intended use.....	21
3.	Technical data.....	21
3.1.	Installation drawing.....	21
3.2.	Electrical data :.....	21
3.3.	Mechanical data :.....	21
3.4.	Climatic data.....	22
3.5.	Acoustic Data :.....	22
4.	Safety Manual.....	24
4.1.	Standard foundation.....	24
4.2.	Features.....	24
4.3.	Qualification.....	24
4.4.	Evaluation.....	25
4.4.1.	Use as a starting alarm of machines.....	25
4.4.2.	Use as an acoustic warning system in one-channel version.....	26
4.4.2.1.	Use as acoustic warning system without test function.....	26
4.4.2.2.	Use as acoustic warning system with test function.....	27
4.5.	Operating behaviour of the monitoring equipment.....	27
4.6.	Time dependencies.....	29
4.7.	Function test.....	29
4.8.	Process safety time.....	30
4.9.	Proof Test.....	30
4.10.	Hardware configuration.....	31
4.11.	Limits of use.....	31
4.12.	Requirements for the installation and putting into service.....	32
4.13.	Connection assignment.....	32
4.14.	Connection requirements.....	34
4.15.	Warning.....	34
4.16.	Maintenance advice.....	34
4.17.	Troubleshooting.....	34
4.18.	Disposal.....	34
5.	Attached form “Service fault recording“.....	68

1. Brief description of the system

The sounders of the DS.-SIL series are audible warnings for the signalling of dangerous situations in safety relevant applications, e.g. as an intrinsic part of an E/E/PE system (according to EN61508).

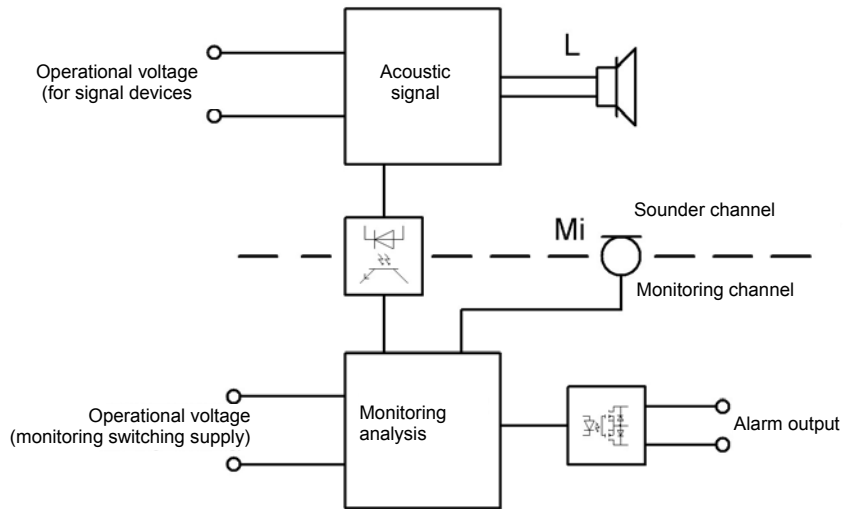

Fig. 1 Overview

The sounders are constructed for the robust requirements in industrial circumstances and can reach a sound level of up to 110dB(A). The sounders suited to indoor and outdoor use create a warning signal in 30 different tones which can be selected with the help of an internal DIP switch. There is also the possibility of (optionally) switching to three other tones with external control. Next to these factory settings, the combination of tones can be freely arranged by on-site programming. The function of the sounder is internally monitored electrically and acoustically by a diagnosis channel. If an acoustic warning signal is made, then an MOS relay is conductive. This information can be interpreted with a superior control.

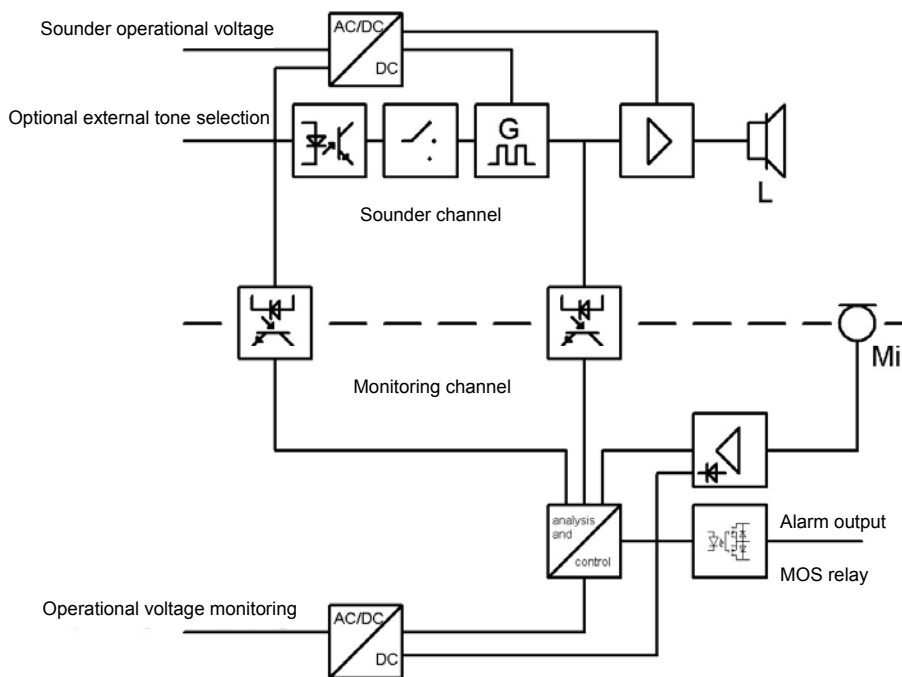

Fig. 2 Illustration of the functionality of the switching parts of the sounder with monitoring

2. Intended use

With a danger and risk analysis, dangers created in the installation can be ascertained. If a dangerous situation is to be avoided, then the sounders can be used as an integral part of a technical safety system (Safety Instrument System - SIS) up to safety integration level 2 (SIL 2).

Because of the very different integration of the sounders in various safety architectures, they must be viewed differently. The following uses are described in the safety manual:

- Use as a starting alarm of machines or similar applications (see section 4.4.1)
- Use as a warning system without automatic test function via a superior control (see section 4.4.2.1)
- Use as a warning system with automatic test function via a superior control (see section 4.4.2.2)

In general, the operational safety of the device and the therefore connected system is only guaranteed during intended use in accordance with the specifications of the operating manual. Custom-designed dangers could result from inappropriate or unintended use of this device.

3. Technical data

3.1. Installation drawing

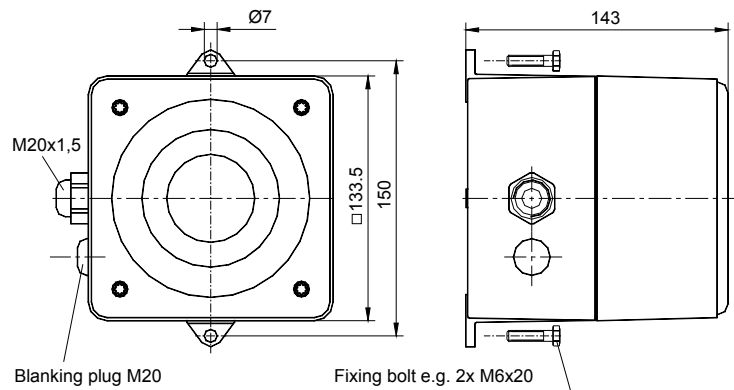

Fig. 3

3.2. Electrical data

	DS10	DS5
Nom. voltage	230V AC	230V AC
Voltage range	95 .. 253V AC	95 .. 253V AC
Current consumption	60 mA @ 230V	40 mA @ 230V
Current consumption monitoring circuit	30mA @ 230V	
Control current option TAS	≤5mA (230V)	
Capacity of failure contact	Solid state relay max. 230V~/80mA $R_{DS(on)} \leq 35\Omega$	
Duty cycle	100 %	
Life time	A replacement of the device is recommended after 20 years or 2500 operating hours.	

3.3. Mechanical data

Degree of protection	IP 66 / 67 (EN 60529)
Protection class	I
Mounting position	Opening of bell mouth shall not point upwards
Cable entry	2x M20x1,5
Clamp range of cable gland	8 – 12 mm
Terminals	Cage Clamp 0,08-2,5mm ² (AWG28-12), (AWG12 THHN, THWN)
Weight	1,95 Kg
Material of housing	Al- die cast GD-Al Si12 Cu
Surface coating	Anodised, Polyester resin varnish, RAL 3000 - flame red

3.4. Climatic data

Operating temperature	- 25 °C + 55 °C
Storage temperature	- 40 °C + 70°C
Relative humidity	90%
Applicability for outdoor use	suitable for outdoor use

3.5. Acoustic data

	DS10-SIL	DS5-SIL
Rated sound level	110 dB(A) / 1m ±3dB	105 dB(A) / 1m ±3dB
Sound patterns	30	

Sound level

DS 10 sound pressure level horizontal diagram

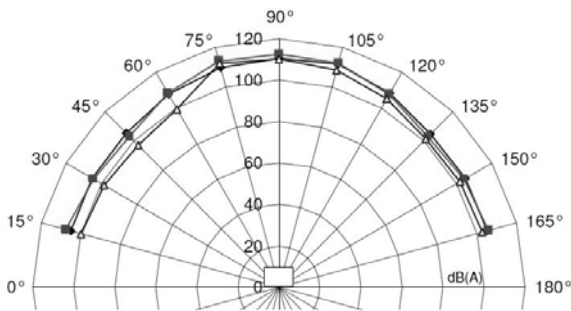

DS 10 sound pressure level vertical diagram

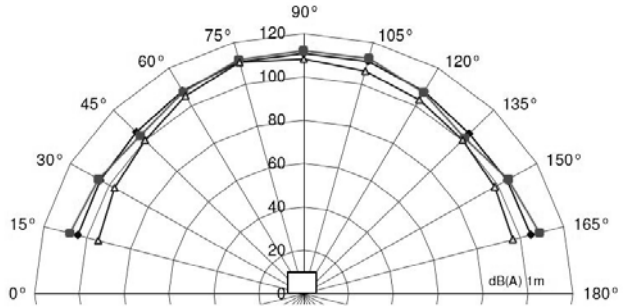

- Tone no. 2
- Tone no. 128
- △ Tone no. 57

Fig. 4

Minimal sound pressure level at $U_b = 19V$ in dB(A) 1m

Tone selection table

Grundton Stufe 1 basic tone stage 1	Kodierschalter/ DIP-Switch						Beschreibung – Grundton Stufe 1 (Voreinstellung: Ton-Nr. 2) Description basic tone stage 1 (stage no. 2 = pre-set) Description du son de base (Préréglage Son-No.2)	Option TAS see section 4.14			
	1	2	3	4	5	6		Stufe 2 stage 2	Stufe 3 stage 3	Stufe 4 stage 4	
0							kein Ton / No tone / Pas de son		2	88	57
2					ON		Notsignal / Unified emergency signal/ signal danger répétitif descendant - DIN 33404/T3 -		128	112	57
15	ON			ON	ON		Tone not suitable for use with monitoring circuit! ansteigender Sägezahn mit Pause / Sawtooth/ Son en dents de scie		131	54	112
23	ON		ON	ON	ON		Sirene / Siren / Sirène montante et descendante		24	60	112
24	ON	ON		ON	ON		Sirene / Siren / Sirène montante et descendante		55	23	131
26	ON	ON	ON		ON		Sirene / Siren / Sirène montante et descendante - Hoechst -		2	100	93
31	ON	ON	ON	ON	ON		Sirene / Siren / Sirène montante et descendante - NF C 48-265 -		128	54	57
32						ON	Auswahl der frei belegbaren Tonkombinationen in Stufe 2, 3 und 4 – Programmierung s. unten/ Selection of the freely assignable tone combinations in stages 2, 3 and 4. For programming see below/ Sélection des combinaisons de sons libres au niveau 2, 3 et 4. Programmation, voir ci-dessous				
36	ON	ON	ON				Sirene / Siren / Sirène montante et descendante		146	67	57
45			ON	ON			Sirene / Siren / Sirène montante et descendante		2	57	93

54	ON	ON	ON		Dauerton / Continuous tone / Son continu	1500 Hz	2	57	67	
55	ON	ON		ON	Dauerton / Continuous tone / Son continu	1200 Hz	2	88	128	
57		ON			Dauerton / Continuous tone / Son continu	950 Hz	2	128	88	
60	ON	ON			Dauerton / Continuous tone / Son continu	825 Hz	24	93	125	
63	ON		ON	ON	Dauerton / Continuous tone / Son continu - Bayer -	725 Hz	2	97	93	
67	ON		ON		Dauerton / Continuous tone / Son continu	500 Hz	24	93	125	
88			ON	ON	Unterbrochener Ton / Interrupted tone / Son intermittent	 950Hz	2	57	128	
90	ON				Unterbrochener Ton / Interrupted tone / Son intermittent	 825Hz	2	127	108	
92	ON			ON	Unterbrochener Ton / Interrupted tone / Son intermittent	 800Hz	131	146	57	
93		ON		ON	Hupe / Electromechanical horn / Trompe électro-mécanique	 800Hz	2	128	57	
97	ON			ON	Unterbrochener Ton / Interrupted tone / Son intermittent	 725Hz	2	63	93	
98		ON			Notsignal Schweden / Swedish imminent danger signal / Son pulsé rapide - SS 031711 -	 700Hz	112	128	57	
100	ON	ON	ON	ON	Unterbrochener Ton / Interrupted tone / Son intermittent	 680Hz	2	57	125	
108		ON	ON	ON	ON	Unterbrochener Ton / Interrupted tone / Son intermittent	 500Hz	2	127	60
112				ON	Notsignal für Räumung/ Audible emergency evacuation signal/ Signal international d'évacuation - ISO 8201 -	 950Hz	2	57	128	
116	ON		ON	ON	Unterbrochener Ton / Interrupted tone / Son intermittent - Schiff verlassen -	 950Hz	117	93	125	
117	ON		ON		Unterbrochener Ton / Interrupted tone / Son intermittent (IMO SOLAS III/50 + SOLAS III/6.4)	 825Hz	93	116	125	
125	ON	ON		ON	Wechselton / Alternating tone / Modulation bi-ton	 1400Hz 1200Hz	57	93	24	
127	ON	ON			Wechselton / Alternating tone / Modulation bi-ton	 1075Hz 825Hz	2	90	60	
128				ON	ON	Wechselton / Alternating tone / Modulation bi-ton	 1025Hz 825Hz	2	112	57
131	ON			ON	ON	Wechselton / Alternating tone / Modulation bi-ton	 1000Hz 800Hz	24	55	23
142	ON	ON		ON	Wechselton / Alternating tone / Modulation bi-ton	 900Hz 500Hz	2	54	88	
146			ON	ON	ON	Feueralarm Frankreich / French Fire sound / Son évacuation urgence - NFS32-001 -	 554Hz 440Hz	128	67	4

Individual combination of the tones for stages 1, 2, 3 and 4 (tone 32 of the Tone Selection Table)

In the case of sounders with external tone selection, the combinations of the tones for the stages 1 to 4 can be altered and thus adapted to the particular application. The tone of stage 1 will continue to be activated with selector switches 1 - 5. Stages 2, 3 and 4 are programmable.

Programming

The programming of stages 2, 3 and 4 can be described as follows:

- De-energise sounders
- Change to programming mode by selector switch position 7 to ON
- Selection of the selected (basic) tone by appropriate selector switch settings 1 - 5.
(see sound selection table, basic tone stage)
- Brief application of service voltage and control voltage to the appropriate input terminals for stages 2, 3 or 4
(see also connection examples, 4.14)

The basic tone set is taken over by the stage activated.

WARNING: When the service voltage is switched on do not touch any live parts of the sounder.

- Repeat for all stages (2 - 4) which are to be activated.
- De-energise sounders
- Switch off programming mode by means of selector switch setting 7 to OFF.

The tone for stage 1 is set, after the programming mode has been left, with the help of selector switches 1 to 5. Selection of the individual tone combination, by setting the selector switch 6 to ON (see Tone Selection Table, Tone Selection 32)

4. Safety Manual

4.1. Standard foundation

- IEC61508 Functional safety of electrical/ electronic/ programmable electronic safety-related systems
- IEC61511 Functional safety – safety instrumented systems for the process industry sector
- EN ISO 13849-1 (following) Safety-related parts of control systems

With the identification of the device with the CE sign, Pfannenberg GmbH confirms the fulfilment of the legal requirements of the applicable EC guidelines.

The DS ..-SIL sounder fulfils the requirements of the functional safety according to IEC 61508, IEC 61511 and EN ISO13849-1

4.2. Features

The sounder described alone does not perform any protective function (partial system), but is conceived for installation as an output device with diagnosis (output) in the loop of a protective function (SIF). The system (see Fig. 1 and Fig. 2) only ever shows a partial system of a technical safety system (SIS). It should be observed through the system integrator that the entire 'loop', according to the use, has to meet the required safety integration level (SIL). The system integrator must establish all measures in order to reach or maintain the safe condition in the SIS in the case of a fault.

The diagnosis system of the device diagnoses the acoustic warning signals of the failed release and function upon request and reports this via an alarm relay to a superior control system.

This does not constitute an online diagnosis within the meaning of IEC61508 and, without further measures, has no influence on the intermediary values PFH, PFD, SFF and HFT. The diagnosis can only be used for the following uses/architectures:

- Systems with small requirement rate of the safety function (low demand) which are regularly subject to a test release. If the regular test is automated, then it can be evaluated so that the diagnosis coverage flows into the calculation of the reliability data.
- Systems in which the safety function can be tested before the existence of the dangerous condition, such as starting alarms of machines, for example.

4.3. Qualification

Handling according to this operating manual and safety manual can only be carried out by trained electrical technical personnel authorised by the plant operator.

The integration of this sounder in an application is to be carried out according to the rules of the functional safety.

Proof tests and their proof can only be carried out by authorised electrical technical personnel.

4.4. Evaluation

4.4.1. Use as a starting alarm of machines

For use as a starting alarm of machines, the function of the generation of the acoustic warning signal channel is to be assessed as a function of the machine. The safe condition is reached when the acoustic warning system works reliably. The diagnosis channel monitors this function and, upon failure, leads in the safe condition via a safety loop. This architecture is illustrated schematically in Fig. 5.

Starting alarms and similar uses are architectures that can normally be attributed to the 'high demand mode'. Immediately before switching on the machine or entering the dangerous condition, an automatic function test must be carried out by a superior control system, such as described in section 4.9. Only after a successful test can there be an approval. This automatic test ensures that the function of the monitoring channel is, in the figurative sense, clearly tested more than it is required ($T_{\text{Test}} \ll T_{\text{required}}$). Test functions in the superior control system and corresponding measures for fault messages must be in accordance with the functional safety according to IEC/EN61508.

The safety loop is made up of diagnosis channel with recording, evaluation of the dangerous condition and elements of the machine control for the reaching of the safe condition. The latter was not taken into account in the analysis.

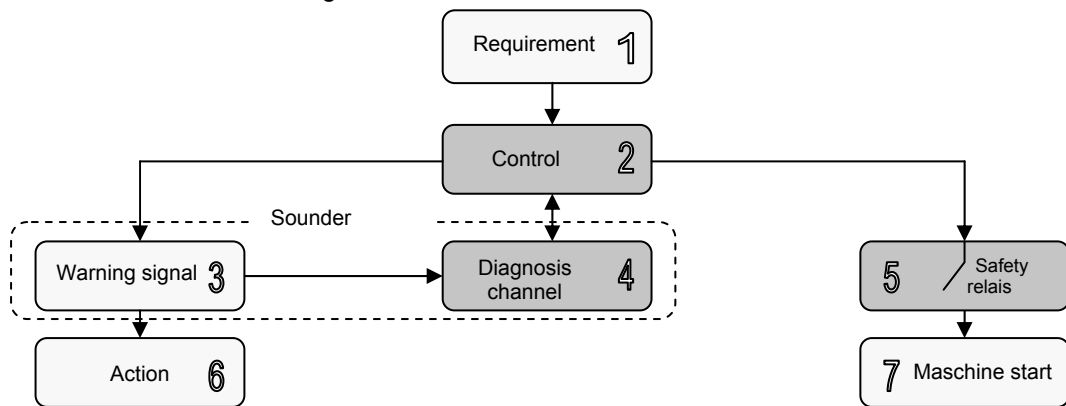

Fig. 5 Starting alarm

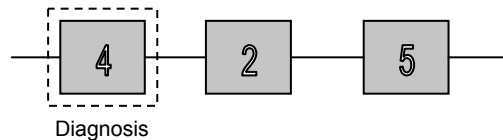

Fig. 6 Safety relevant block diagram

PFH _G	3,9 x 10 ⁻⁹	1/h
SFF	99	%
DC	94,9	%
MTTF _d	>100	Years
λDiagDU	4	Fit
λDiagDD	73	Fit
λDiagS	7460	Fit
HFT	0	
Architecture type IEC/EN61508	B	
Suitability of the system for use in safety chains until	SIL 2	
Category (DIN EN ISO13849)	2	
PL (DIN EN ISO13849)	d	

4.4.2. Use as an acoustic warning system in one-channel version

The function of the acoustic warning system is to be assessed as a safety function in the use as a warning system after recording dangerous conditions. A measurement records a dangerous condition and introduces the safe condition by controlling the acoustic warning system (personnel/operator is warned).

Note: The warning of people is a voluntary measure as it requires willing handling of one or more people. This architecture only corresponds to the requirements of the European Machinery Directive if, according to state-of-the-art technology, no constructive safety or other voluntary measure is possible to reach a safe condition.

The diagnosis can only be taken into account if there is regular, automated function checking, the minimum interval of which must be in accordance with approx. ten to one hundred times the requirement rate according to IEC/EN61508. This possibility is only available in low demand mode and is further described and evaluated in section 4.4.2.2.

The acoustic warning system with diagnosis function is implemented as follows:

- A measurement (input (1), logic (2)) records a dangerous condition and activates the acoustic warning system (output (3))
- The diagnosis (4) monitors the function of the acoustic warning system and reports OK to a superior control system (5)
- If an OK message takes place, then the superior control system (5) introduces the safe condition via other measures (6).

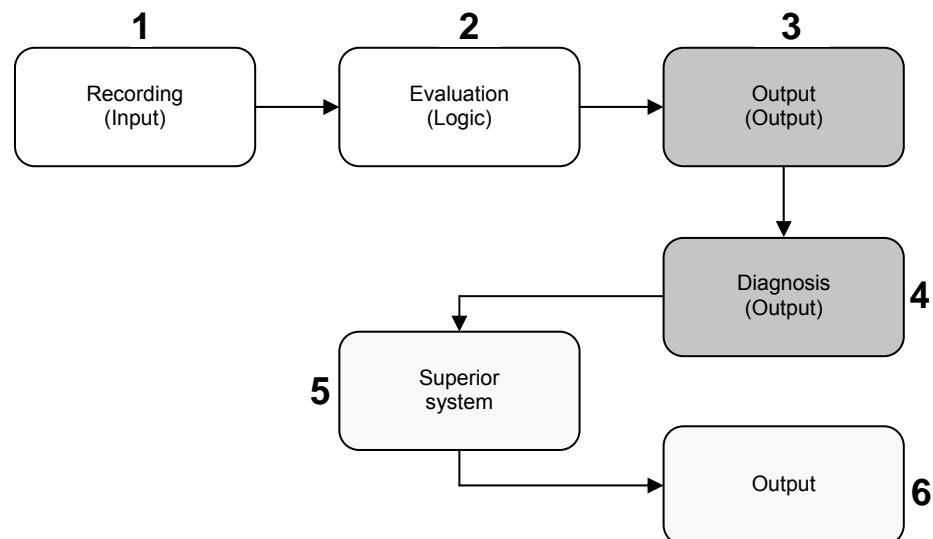

Fig. 7 Warning system

Fig. 7. In section 4.4.2.2 the sounder partial systems (output - position 3) and diagnosis channel (diagnosis - position 4) are evaluated. It should be noted that the sum of all PFH or PFD values must correspond to the required safety integration level for the entire system.

4.4.2.1. Use as acoustic warning system without test function

The safety function – generating a warning signal – is realised via a one-channel system (1oo1 according to IEC/EN61508) without taking account of the diagnosis function, as also described in section 4.2.

The low and high demand mode is useable in the system without the automatic test function.

Evaluation for applications with high requirement rate or continuous requirement (high demand) and low requirement rate (low demand) without automatic test release of the monitoring equipment.

T-Proof Test	1a	15a	
PFD _{mean}	1,66E-03	2,50E-02	1/requirement
PFHG	3,80E-07		
SFF	95,3		%
DC	0,0		%
MTTR	1		h
$\lambda_{DU,eff.}, \text{Sounder}$	372		Fit
$\lambda_S, \text{Sounder}$	182		Fit
$\lambda_{DU}, \text{Diagnosis}$	77		Fit
$\lambda_S, \text{Diagnosis}$	7460		Fit
β (CCF)	10		%
$\lambda_{DU}, \text{complete}$	380		Fit
$\lambda_S, \text{complete}$	7710		Fit
MTTF _d	>100		a
HFT	0		
Category	1		
SIL	2	1	
Type	B		
PL	c	c	

The monitoring of the function of the sounder is used during the proof test. The 'proof test' is described in section 4.10 of the operating instructions/safety manual.

4.4.2.2. Use as acoustic warning system with test function

This monitoring can only be used with systems in low demand mode. The test function, as described in section 4.7, is taken into account. This must be automated and must take place at least ten to one hundred times more often than the expected requirement rate. The system with test function, including the diagnosis and respective measures in the fault message, must be in accordance with the requirements of the function safety according to IEC/EN61508.

In the following, a requirement rate less frequent than once a year is assumed (low demand).

Automatic test interval	monthly (672h)	weekly (168h)	daily (24h)	monthly (672h)	weekly (168h)	daily (24h)	
Proof test interval	1	1	1	15	15	15	a
PFD _{mean}	3,62E-04	2,81E-04	2,58E-04	3,92E-03	3,84E-03	3,82E-03	1/ requirement
SFF _{eq}	99,0	99,2	99,3	99,3	99,3	99,3	%
DC _{eq}	78,2	83,1	84,5	84,3	84,6	84,7	%
MTTR	1						h
$\lambda_D, \text{Sounder}$	372						Fit
$\lambda_S, \text{Sounder}$	182						Fit
$\lambda_{DU} \text{Diagnosis}$	77						Fit
$\lambda_S \text{Diagnosis}$	7460						Fit
β (CCF)	10						%
$\lambda_{DU} \text{complete}$	380						Fit
$\lambda_S \text{complete}$	7710						Fit
MTTF _d	>100						a
HFT	0						
Architecture type	B *						
Suitability of the system for use in safety chains until	2						
Category (DIN EN ISO13849)	2						
PL (DIN EN ISO13849)	c						

* Because of the complex integration of the system in the checking processes of the operation, the system is classed as type B under inclusion of the test releases and diagnosis in a superior control technology.

4.5. Operating behaviour of the monitoring equipment

For the evaluation of the monitoring a superior control system, which is in accordance with the functional safety requirements of IEC/EN61508, must be available. The control system must be capable of carrying out a fault analysis according to the capacity of failure in connection with the operational condition of the sounder. The following dependencies between operational condition and capacity of failure are therefore possible. Please also take note of the possible switching status as shown in Fig. 8 and Fig. 9.

It is assumed that the monitoring equipment is supplied with operational voltage at least 1s before switching the sounder channel on and the condition of the alarm output is checked 0.5s after switching on at the earliest. This procedure is an integral part of the automatic test function, as described in section 4.7.

- a) Switching on the power supply of the sounder channel in a fault free condition results in the controlling of the MOS relay (the output of the MOS relay is low resistance). This takes place with a delay of 0.2 seconds. This is on the condition that a tone has been selected with help of the DIP switch for the tone selection or a respective tone has been activated from the 'external tone selection' and the monitoring circuit is attached to the power supply. If the capacity of failure has not become low-resistance after this time then a fault has occurred in the supply of the sounder channel, in the sounder channel itself or in the monitoring equipment. If the capacity of failure is already low-resistance beforehand, then there is a conductor end or a malfunction in the monitoring circuit.
- b) If the operational voltage of the sounder channel is switched off, a fault message is given via the fault alarm relay with a delay of 0.2s to 2.5s. With an uninterrupted sounding, a reaction of the alarm relay of >0.2s can be expected. The longer delay can result in tonal pauses in uninterrupted sounding when switching off.
- c) If tones are automatically ended by the sounder (such as with tones 26 and 98, for example) then a fault is also reported after 4s. In this case, the control must take into account the procedure of the tonal generation (60s) and reset it.
- d) If, during operation of the sounder channel, it is the case that the sounder remains off without the operational voltage for the sounder channel being switched, the alarm output becomes high-resistance after a maximum delay of 4s and therefore a fault is reported.
- e) The minimum duration of an alarm is 5s. Only after this time has lapsed does it switch back to the normal monitoring mode.

4.6. Time dependencies

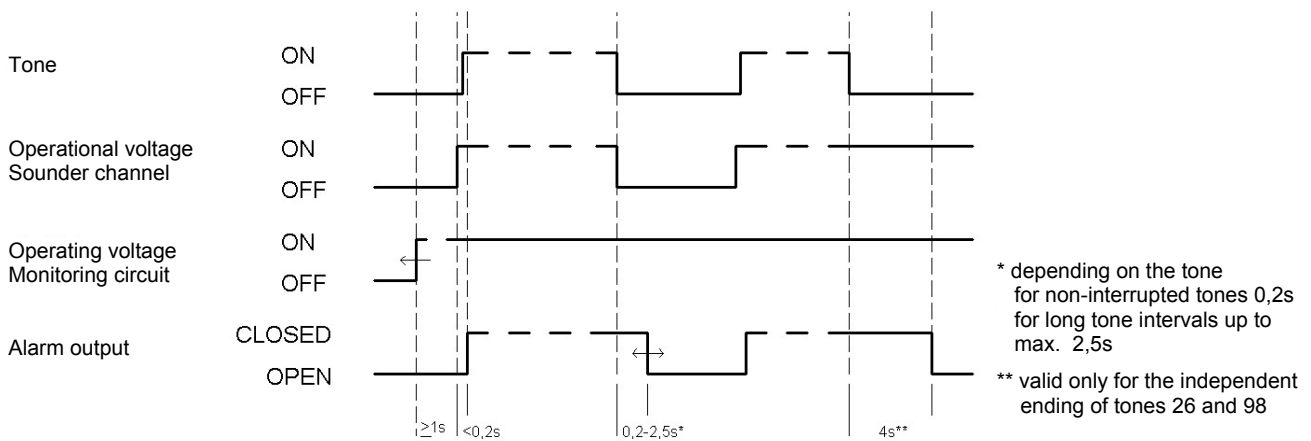

Fig. 8 Function time diagram

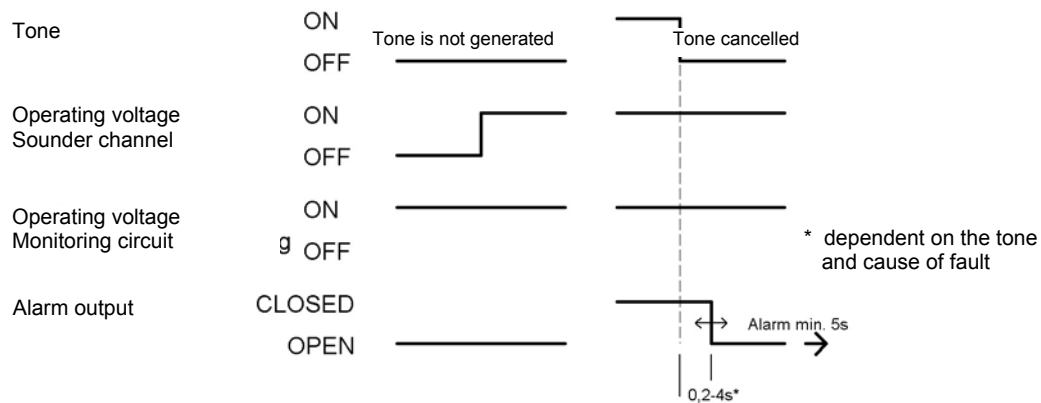

Fig. 9 Function time diagram with fault

4.7. Function test (Low Demand Mode)

For applications in 'low demand mode' with safety requirements an automatic function test should be carried out with regular intervals. The test intervals can be seen in section 4.4.2.2 .

Both part systems, the sounder channel and the monitoring circuit, have separate power supply connections. This means that a check of the function is possible and can be carried out as follows (time dependencies see Fig. 8 and Fig. 9).

- Switching on the monitoring power supply when the sounder channel is not activated, (can be omitted depending on use if the monitoring is continuously connected to the supply)
- Check whether the fault alarm relay has high-resistance $>0.5s$ after switching on,
- Switching on the sounder channel (sound is generated)
- Check whether the fault alarm relay has switched after $>0.2s$ (low-resistance)
- Switching off the operational voltage of the sounder channel, the fault alarm relay must have fallen away (high-resistance) after 2.5s at the latest
- Switching off the monitoring (depending on use)

It is important for the system test that the change of the switch position of the alarm relay is detected depending on the generation of the acoustic warning signal. With which distances a system test has to take place is dependent on the eventual use in which the sounder is involved. The equipment specific check intervals must be defined in the respective proof of safety.

The function test can be shortened if a tone without interrupted tones is used. Then time in point e) can be reduced to 0.3s.

It is required that a tone is selected at the DIP switch of the sounder or a tone is activated simultaneously with the sounder from the 'external tone selection' option.

4.8. Function test (starting alarm)

The algorithm, as described in section 4.7, must be carried out immediately before every time the machine is switched on.

Note: in doing so the functionality of the monitoring channel (diagnosis channel) is tested according to the IEC61508 required frequency.

4.9. Process safety time

Conclusions for the required process safety time can be drawn depending on use according to the function time diagrams. The reaction times for the generation of the acoustic warning signal and the switching status of the alarm relay depending on the switching on and off time of the operational voltage (Fig. 8) and in the case of a fault (despite demand, the warning signal is not generated, Fig. 9) are illustrated here.

With the connection of the operational voltage, the sounder generates an acoustic warning signal after 0.3s at the latest and reports this via the alarm relay (output low-resistance). This means the 'generation of a warning signal' safety function has been activated. Further explanations of the reaction times of the alarm relay can be found in section 4.7.

4.10. Proof Test

Manual checks of the safety function and the visual condition of the sounder are to be performed in regular intervals. This test serves to identify dangerous faults that are not automatically detected and the general condition of the device. If the proof test is not carried out in the required, defined, timely intervals this leads to the loss of the reachable SIL evaluation. The sequence of the carrying out of the individual test steps of the proof test is arbitrary. The 'proof test' is to be carried out as follows:

Test	Test step	Test instructions
Visual check	a.) Housing	mechanical damage, corrosion damage, attachment to the location
	b.) Horn outlet	not covered or locked
	c.) Cable screw joint	tight fit, seal for the cable guaranteed
Electronic function	d.) manual function test	- manual, step-by-step deployment of the individual test steps as described in section 4.7 under use of one of the following tones: 88, 90, 92, 100, 108, 112, 116, 117 (Important – interrupted sound with intervals >0.5s!, recommended tone no. 117), adjust respective tone with DIP switch - Check of the respective switching status of the alarm relay of the monitoring circuit with check of the specified max. switching times (< 0.2s sound on, < 2.5s sound off, see also Fig. 8) - acoustic check whether a sound is generated upon request
	e.) Electrical isolation	Check the isolation between the alarm relay output and connection of the operational voltage supply of the monitoring channel. Also, the connections to X3 should be disconnected. The connection X3 contact 3(4) to contact 5(6) is to be checked with a current flow check. This must be high-resistance (>1MΩ).
Acoustic function	f.) Tone	Acoustic check of the tone pattern of the locally used tone. This can take place subjectively by trained personnel. The pattern (intervals, frequency response curve, frequency change, interval times) is to be checked as shown in the tone table in section 3.5. The person must be capable of identifying the warning signal. Alternatively, technical implements suitable for this test can be used. The signal can be taken oscillographically for analysis with a microphone and preamplifier or electronically from PIN13 of the integrated switch U4 (earth connection to the heat sink of the U3 switching circuit, TTL level).
	g.) Tone option TAS	The test step 'f.) Tone' must be repeated for every additionally activated tones in the application when using the 'external tone selection' option.
	h.) Noise level check	Noise level measurement or subjective assessment of the noise level by a representative group of people during a test release under max. ambient noise level. The noise level must be more than +10dB above the max. ambient noise level or be clearly recognisable by this group of people. The tone in the system is to be used. Alternatively, a noise level measurement can be taken in an anechoic room or under open-air conditions. In this case, for tone no. 57, a noise level of at least the rated sound level -3dB(A) must be reached with a metre distance.
Logging	i.) Log of the test results	must comply with the rules for functional safety according to IEC/EN61508

4.11. Hardware configuration

The adjustment of the hardware is restricted to the choice of the tone on DIP switch S1. The tone and related DIP switch generation is taken from the tone table in section 3.5. The position and assignment of the DIP switch are illustrated in section 4.14.

The combination of tones – this is only relevant for versions with external tone selection – can be adjusted. The programming for tone 32 is described in section 3.5.

4.12. Limits of use

The limits that can be taken from the technical data in section 3 are to be kept.

The limits for the calculation of the safety integrity of the sounder in systems is to be taken from section 4.4.

Changes to the sounder are only possible via the manufacturer. The safety parameters must be recalculated and the functional safety must be tested. Changes by the user are not allowed and lead to voiding of the warranty.

4.13. Requirements for the installation and putting into service

- a) The sounder corresponds to state-of-the-art technology and was constructed taking into account the specific regulations and guidelines.
- b) The operating manual and the safety manual are aimed at educated and authorised electrical technical personnel. Their contents must be made available to the technical personnel and implemented.
- c) The electrical connection can only be carried out by persons authorised for this. Before connecting it is to be ensured that the sounder is not live.
- d) The safety instructions of this operating manual, the local installation standards as well as the valid safety regulations and accident prevention guidelines are to be observed.
- e) The sounder must be selected so that a clear perceptibility of the acoustic signal at maximum ambient noise level can be guaranteed. The warning signal must exceed the ambient noise level by +10dB(A).
- f) When using numerous signals (tones), they must be clearly distinct in order to enable specific actions by trained personnel.
- g) Do not install two warning devices directly next to one another as mutual influencing during simultaneous operation cannot be ruled out. A distance of >1m fulfils the requirement.
- h) The front part can be removed by releasing the 4 screws on the front side. Ensure a clean and undamaged seal during the installation.
- i) The connection assignment is illustrated in section 4.14.
- j) The cable screw joints with which the device is equipped are intended for round cable cross-sections and an outer diameter of 8mm to 12mm. This guarantees the seal effect of the cable screw joint. If cables with other diameters or shapes are to be used, then other suitable cable screw joints must be used. The IP protection category IP67 cannot be impaired.
- k) During installation make sure that the cable(s) is/are secured against pulling and twisting. Please note: the devices are not intended for mobile use.
- l) The opening of the horn is not to be facing upwards, particular when in use outside or in a dusty area.
- m) The tones are set with help of the DIP switch S1, see tone table section 3.5.
- n) The housing screw plugs (Torx-T20) of the sounder part are to be tightened with a torque of approx. 2 - 2.5 Nm for at least two cycles when closing the housing.
- o) The correct function of the sounder is to be checked when newly commissioned, recommissioned and after every repair. The safety function in particular is to be validated. The function test as described in section 0 is also to be carried out.
- p) Before repair, the supply voltage on the type plate is to be checked. The wrong operational voltage can lead to damages or to the destruction of the equipment.
- q) The sounder can only be operated in an undamaged and operationally safe condition within the specific data.
- r) The operator is responsible for the trouble-free operation of the device.

4.14. Connection assignment

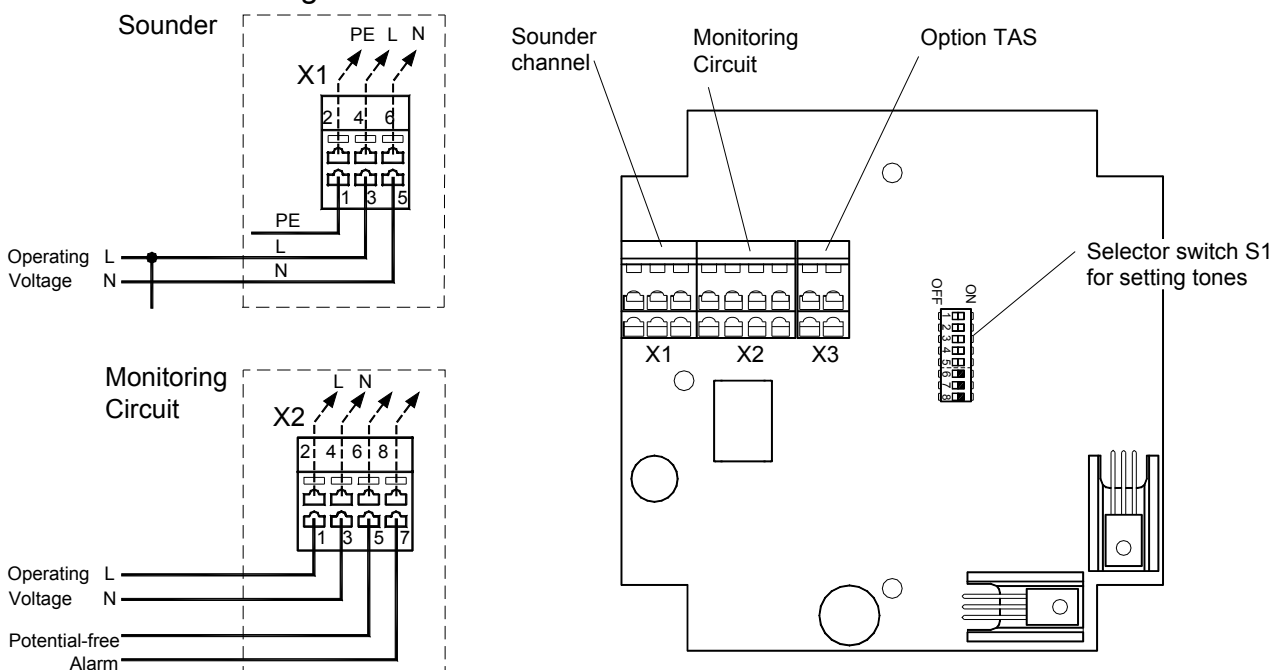

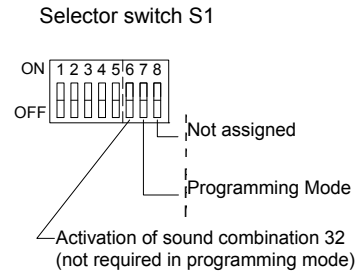
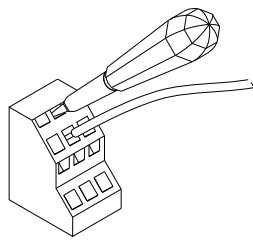

Fig. 10 Connection assignment and control elements

Terminal connections X1

1	2	PE
3	4	L - sounder operational voltage
5	6	N - sounder operational voltage

Terminal connections X2

1	2	L – monitoring channel operational voltage
3	4	N – monitoring channel operational voltage
5	6	Potential-free alarm contact (IN), MOS-Relay, 230V~/ 80mA
7	8	Potential-free alarm contact (OUT), MOS-Relay, 230V~/ 80mA

External tone selection via control voltage – short term –TAS

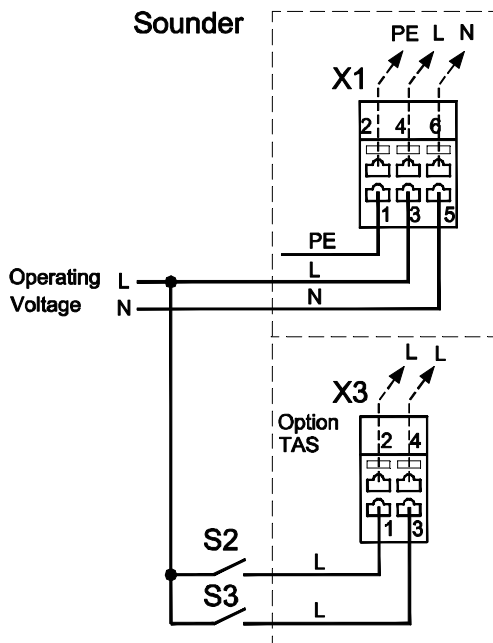

		Ub	S2	S3
Stage	1	x		
Stage	2	x	x	
Stage	3	x		x
Stage	4	x	x	x

x = closed

Fig. 11 Optional connection assignment TAS

Terminal connections X3

(Option external Tone selection –TAS)

1	L - Control voltage Tone Stage 2
2	L - Control voltage Tone Stage 2
3	L - Control voltage Tone Stage 3
4	L - Control voltage Tone Stage 3

4.15. Connection requirements

Electricity and voltage limiting measures must be implemented in the superior system for the supply as well as for the fault report interface.

4.16. Warning

WARNING	<i>Detriment to hearing</i> In order to avoid a detriment to hearing, when working directly next to the sounder, ear protection is to be worn.
----------------	--

DANGER	<i>Danger of electric shock!</i> Before all work on equipment, the following should be observed: switch off the equipment before opening. All work on the equipment is only to be carried out by authorised technical personnel
---------------	---

4.17. Maintenance advice

The sounder does not require any special maintenance. However, the 'proof test' interval should be observed.

Changes, modifications, faulty and incorrect use as well as not observing the advice of this operating manual void the warranty.

External cleaning should be done with weak soapy water without use of solvents.

4.18. Troubleshooting

Despite high functional safety, faults can occur during use. These can have consequences in the sounder, in the operational voltage supply or in the evaluation in the control system.

It is the responsibility of the plant operator to take suitable measures to deal with occurred faults.

The first measure can be to check the operational voltage, check whether an acoustic warning signal is generated and check the position of the alarm relay contacts, depending on the operational condition of the sounder. The cause of the fault can thereby be traced. A step-by-step function test as described in section 4.7 and carried out during the 'proof test' in section 4.10 can also help a lot.

If the sounder is defective, it should be repaired in the production plant. Only original replacement parts can be used as replacements.

Faults that affect the functional safety are to be reported to the manufacturer. For a smooth process, please use the form attached and send it to the following address.

Post: Pfannenberg GmbH
Service
Werner-Witt-Str.1
D-21035 Hamburg
E-Mail: Service@Pfannenberg.com
Fax: 49 (0)40 73412-102

You can reach the service or technical support on +49 (0)40 73412 -0.

4.19. Disposal

Recycling of the device can be carried out by specialist operations. The electronics can therefore be easily removed from the housing. The housing material is made from aluminium die casting and the magnet from ferro-magnetic material.

Should you not have an opportunity to dispose of the old device correctly, please speak to us about returns and disposal.

The device at hand is not subject to the WEEE guideline 2002/96/EC and the respective national laws. The device is only to be sent to a specialist recycling operation and not to be disposed at communal collection points.