



## 1) Introduction

The BExL25E and BExL15E are second generation flameproof /increased safety loudspeakers which are certified to the European Standards EN60079-0:2006, EN60079-1:2007 and EN60079-7:2007 and meet the requirements of the ATEX directive 94/9/EC. The loudspeakers can be used in hazardous areas where potentially flammable atmospheres may be present. There are three versions of each loudspeaker, 8 ohm or 16 ohm or 100V Line transformer. On 100V line transformer units there are four output tappings for each size of loudspeaker. The BExL25E unit produces output levels in the 117dB(A) range and the BExL15E unit produces output levels in the 112dB(A) range. Both loudspeakers can be used in Zone 1 and Zone 2 areas with gases in groups IIA, IIB and IIC and temperature Classifications of T1, T2, T3 and T4. For ambient temperatures over +55°C the gas groups are limited to IIA and IIB.

## 2) Marking

All units have a rating label, which carries the following important information: -

Unit Type No. BExL25E or BExL15E

Impedance: 8 ohm or 16 ohm  
100V Line

Epsilon x:  
Equipment Group  
and Category:

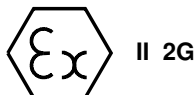

Codes: II 2G Ex de IIC T4 for Ta -50°C to +55°C  
II 2G Ex de IIB T4 for Ta -50°C to +70°C

Certificate No. KEMA 99ATEX7906

CE Marking:  
Notified Body No.

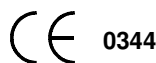

**“Warnings”** DO NOT OPEN WHEN AN EXPLOSIVE  
GAS ATMOSPHERE IS PRESENT

COVER BOLTS CLASS A4-80

USE HEAT RESISTING CABLES AND CABLE GLANDS  
(Rated 110°C) AT AMB. TEMPERATURES OVER 40°C

Year of Construction /  
Serial No. i.e. 09 / 3L43000001

## 3) Type Approval Standards

The loudspeakers have an EC Type examination certificate issued by KEMA and have been approved to the following standards: -

EN60079-0:2006 General Requirements  
EN60079-1:2007 Flameproof Enclosure 'd'  
EN60079-7:2007 Increased Safety 'e'

## 4) Installation Requirements

The loudspeakers must be installed in accordance with the latest issues of the relevant parts of the EN60079 standards or the equivalent IEC standards – Selection, Installation and maintenance of electrical apparatus for use in potentially explosive atmospheres (other than mining applications or explosive processing and manufacture):-

EN60079-14:2008 Electrical Installations in Hazardous  
Areas (other than mines)  
EN60079-10:2003 Classification of Hazardous Areas

The installation of the units must also be in accordance with any local codes that may apply and should only be carried out by a competent electrical engineer who has the necessary training.

## 5) Zones, Gas Group, Category and Temperature Classification

The BExL25E and BExL15E loudspeakers have been certified Ex de IIC T4 for Ta -50°C to +55°C and Ex de IIB T4 for Ta -50°C to +70°C. This means that the units can be installed in locations with the following conditions:-

### Area Classification:

Zone 1	Explosive gas air mixture likely to occur in normal operation.
Zone 2	Explosive gas air mixture not likely to occur, and if it does, it will only exist for a short time.

### Gas Groupings:

Group IIA	Propane
Group IIB	Ethylene
Group IIC (Up to +55°C only)	Hydrogen and Acetylene

**Equipment Category:** 2G

### Temperature Classification:

T1	400° C
T2	300° C
T3	200° C
T4	135° C

### Ambient Temperature Range:

-50°C to +55°C Gas Groups IIA, IIB and IIC  
-50°C to +70°C Gas Group IIA and IIB

## 6) Loudspeaker Location and Mounting

The location of the loudspeakers should be made with due regard to the area over which the unit must be audible. The loudspeakers should only be fixed to services that can carry the weight of the unit.

The loudspeakers should be securely bolted to a suitable surface using the 7mm diameter boltholes in the stainless steel U shaped mounting bracket (see figure 1). The angle can then be adjusted in the direction that the sound is primarily required to cover. This can be achieved by loosening the two large bracket screws in the side of the unit, which allow adjustment in steps of 18°. On completion of the installation the two large bracket adjustment screws on the side of the unit must be fully tightened to ensure that the loudspeaker cannot move in service.

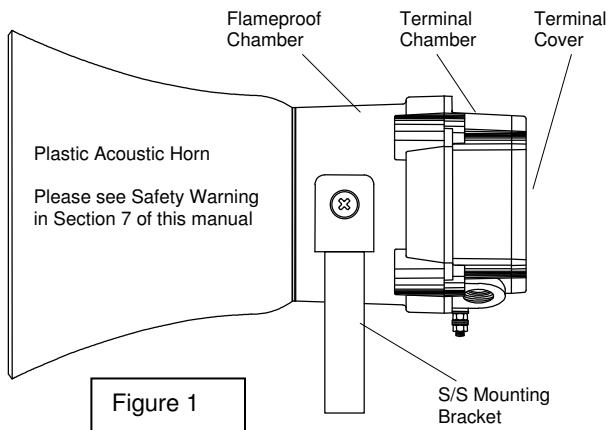

Figure 1

## 7) Safety Warning (Electrostatic Hazard)

The acoustic horn section is made of ABS Plastic, therefore to avoid a possible ELECTROSTATIC CHARGE the unit must only be cleaned with a damp cloth.

## 8) Access to the Flameproof Enclosure

Access to the flameproof enclosure will not normally be necessary as the cables enter the unit in the Ex 'e' Increased Safety Termination enclosure. Access will only be required if you need to fit an end on line monitoring component (see section 15 of this manual). To gain access to the flameproof enclosure, remove the four M6 hexagon socket head screws (see figure 2) and withdraw the terminal chamber taking extreme care not to damage the flameproof joints in the process.

Note the four **M6 screws are Class A4-80 stainless steel and only screws of this category can be used on these sounders.** It is therefore important that these screws and their spring washers are kept in a safe place during installation.

On completion of the fitting of the monitoring component the flameproof joints should be inspected to ensure that they are clean and that they have not been damaged during installation. Also check that the earth bonding wire between the two casting sections is secure and that the 'O' ring seal is in place. When replacing the terminal chamber section casting, ensure that it is square with the flameproof chamber casting before

inserting. Carefully push the section in place allowing time for the air to be expelled. Only after the section is fully in place should the four M6 Stainless Steel A4-80 cover bolts and their spring washers be inserted and tightened down. If the section jams while it is being inserted, carefully remove it and try again. Never use the M6 cover bolts to force the cover into position.

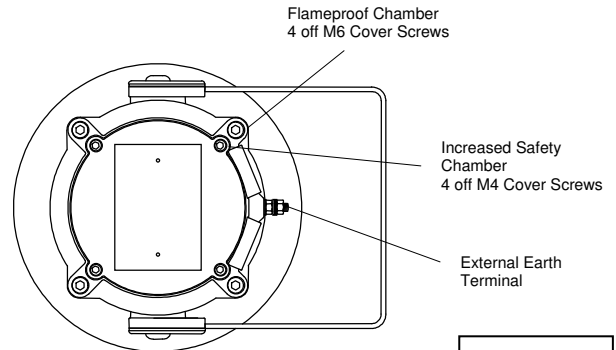

Figure 2

## 9) Access to the Increased Safety Terminal Chamber

To connect the cables to the loudspeaker it is necessary to remove the terminal cover to gain access to the termination chamber. To achieve this remove the four M4 hexagon socket

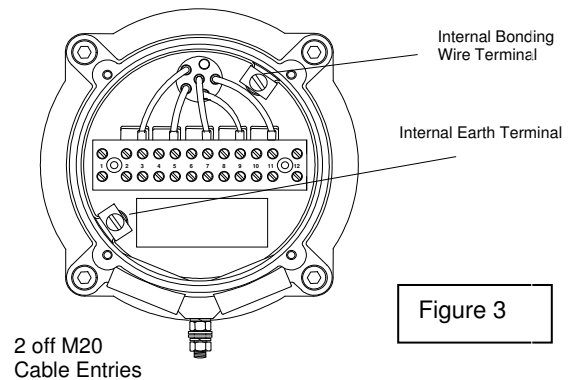

Figure 3

head screws (see figure 2). The four M4 screws and their spring washers are grade A4 stainless steel and they should be kept in a safe place during installation. Before replacing the terminal cover ensure that the earth bonding wire between the two castings is secure and that the 'O' ring seal is in place. Insert the four M4 hexagon screws and their spring washers and tighten them down.

## 10) Power Amplifier Selection

It is important that the loudspeakers are connected to power amplifiers that have outputs that are compatible to the type of loudspeaker being used. Loudspeakers with a 100V line matching transformer fitted must be connected to a power amplifier with a 100V line output. Low impedance 8 ohm or 16

ohm loudspeakers must be connected to amplifiers with a suitable low impedance output.

The following table shows the range of loudspeakers:-

Unit Type	Input	Wattage	Max. I/P Volts
BExL25E	100V Line	25W	100V
BExL25E	8 ohm	25W	14.14V
BExL25E	16 ohm	25W	20V
BExL15E	100V Line	15W	100V
BExL15E	8 ohm	15W	10.95V
BExL15E	16 ohm	15W	15.49V

The above table also shows the maximum AC signal voltages at which the loudspeakers can be operated.

The current levels taken by the each loudspeaker will depend on which output tapping has been selected (see section 14 of this instruction manual). BExL25E 100V Line units have output levels of 25W, 12.5W, 6W and 2W, BExL15E 100V Line units have output levels of 15W, 7.5W, 3W and 1W.

## 11) Cable Selection

When selecting the cable size consideration must be given to the current that each unit draws, the number of loudspeakers on the line and the length of the cable runs.

**SAFETY WARNING:** If the loudspeakers are used at high ambient temperatures, i.e. over +40°C, then the cable entry temperature may exceed +70°C and therefore suitable heat resisting cables must be used, with a rated service temperature of at least 110°C.

## 12) Earthing

All loudspeakers must be connected to a good quality earth. The units are provided with internal and external earthing terminals which are both located on the terminal chamber section of the unit (see figures 2 and 3).

When using the internal earth terminal ensure that the stainless steel M4 flat washer is between the incoming earth wire and the enclosure.

When using the external earth terminal a cable crimp lug must be used. The cable lug should be located between the two M5 stainless steel flat washers. The M5 stainless steel spring washer must be fixed between the outer flat washer and the M5 stainless steel nut to ensure that the cable lug is secured against loosening and twisting.

The internal earth bonding wires ensure that a good quality earth is maintained between the flameproof chamber casting, the terminal section casting and the terminal cover casting.

## 13) Cable Glands

The BExL25E and BExL15E loudspeakers have dual cable gland entries which have an M20 x1.5 entry thread as standard or a PG13.5 thread as a special. Only cable glands approved for Ex 'e' applications or better (i.e. Ex 'd' applications) can be used. They must be suitable for the type of cable to be used

and also meet the requirements of the Ex equipment installation standard EN60079-14:2008.

**SAFETY WARNING:** If the loudspeakers are used at high ambient temperatures, i.e. over +40°C, then the cable entry temperature may exceed +70°C and therefore suitable heat resisting cable glands must be used, with a rated service temperature of at least 110°C.

If a high IP (Ingress Protection) rating is required then a suitable sealing washer must be fitted under the cable gland.

When only one cable entry is used the other one must be closed with an Ex 'e' blanking plug, which must be suitably approved for the installation requirements.

## 14) Cable Connections

The cable connections are made into an Ex e II approved twelve way terminal block (six way on low impedance units) which is located in the Increased Safety Area terminal chamber (see figure 3). See section 9 of this manual for access to the terminal chamber. When wiring into Increased Safety Area terminal enclosures, you are only permitted to connect one wire into each way on the terminal block. Therefore in order that loudspeakers can be connected in a parallel line, the terminal block is fitted with approved connecting combs so that each electrical connection has two terminals in parallel. Terminal No's. 1 and 12 (1 and 6 on low impedance units) must not be used on any units. Cables with a cross-sectional area of up to 4mm<sup>2</sup> can be connected to the terminal block. Cables that have a small cross-sectional area should be fitted with crimp ferules.

The low impedance loudspeakers are fitted with two pairs of terminals 2-3 and 4-5.

The 100V Line loudspeakers are fitted with five pairs of terminals. Terminals 10-11 which are the common and one of the other four pairs of terminals 8-9, 6-7, 4-5 or 2-3 should be selected depending on what output level is required (see the following table).

Terminals	BExL25E (25W) 100V Line	BExL15E (15W) 100V Line
10-11 to 8-9	25W	15W
10-11 to 6-7	12.5W	7.5W
10-11 to 4-5	6W	3W
10-11 to 2-3	2W	1W

## 15) End of Line DC Monitoring

On BExL25E and BExL15E loudspeakers, dc line monitoring can be used if required. Both the 100V Line units and the Low Impedance units have a blocking capacitor fitted. It should be noted that each loudspeaker has a 1M ohm bleed resistor connected across the blocking capacitor and this should be taken into account when selecting the value of the end of line monitoring resistance.

BExL25E and BExL15E 8 ohm and 16 ohm Loudspeakers

Flameproof Enclosure

The end of line monitoring resistor can be connected to the end of line unit. **Note the monitoring resistor MUST be connect to the terminals in the flameproof enclosure, it MUST NOT be connect to the terminals in the Increased Safety termination enclosure (see section 8 of this manual for access to the flameproof enclosure).** Figures 4 and 5 show the terminals in the flameproof enclosures for the 100V Line and low impedance units respectively. On the low impedance units care must be taken with the polarity of the monitoring voltage.

On 100V line units the end of line resistor used must have a minimum resistance value of 4k7 ohms and a minimum wattage of 2.5 watts. The terminal numbers, across which the resistor should be fitted, will depend on the output level selected and are given in the following table:-

Terminals	BExL25E (25W)	BExL15E (15W)
A - B	25W	15W
A - C	12.5W	7.5W
A - D	6W	3W
A - E	2W	1W

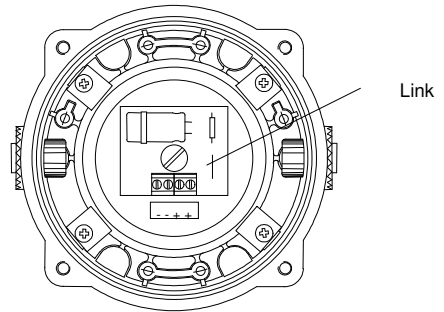

Figure 5

BExL25E and BExL15E 100V Line Loudspeakers

Flameproof Enclosure

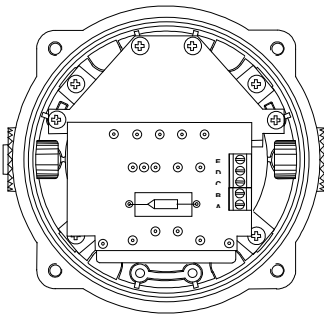

Figure 4

On low impedance units the end of line resistor used must have a minimum resistance value of 2k ohms and a minimum wattage of 0.5 watts or a minimum resistance value of 500 ohms and a minimum wattage of 2 watts. On the low impedance units care must be taken with the polarity of the monitoring voltage. If an end of line resistor is fitted to a unit the links on the printed circuit boards of all loudspeakers in the line must be cut for the dc blocking capacitors to be in circuit in order to dc monitor the line (see figure 5).