



1) Introduction

The BExBG15E and BExBG10E beacons are second generation flameproof beacons which are certified to the European Standards EN60079-0:2006, EN60079-1:2007, EN60079-7:2007, the Combustible Dust standards EN61241-0:2006, EN61241-1:2004 and meet the requirements of the ATEX directive 94/9/EC. The beacons produce synchronised visual warning signals and can be used in hazardous areas where potentially flammable gas and dust atmospheres may be present. The BExBG15E has an output level of 15 joules and the BExBG10E has an output level of 10 joules. The beacons can be used in Zone 1 and Zone 2 areas with gases in groups IIA, IIB and IIC and Temperature Classifications of T1, T2, T3 and T4. The beacons can also be used in the temperature classification T5, if the upper ambient temperature is restricted to +40°C. The units can be used in Zone 21 and Zone 22 areas for combustible dusts and have an IP rating of IP 66 and a surface temperature of T125°C based on max Ta of +70°C.

2) Marking

All units have a rating label, which carries the following important information:-

Unit Type No. BExBG15E and BExBG10E

Input Voltage: DC Units 24V or 48V or 12V (10J only)
AC Units 230V or 115V

Epsilon x:
Equipment Group and
Category:

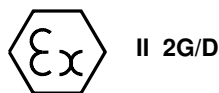

Codes: II 2G Ex de IIC T4 for Ta -50°C to +70°C
II 2G Ex de IIC T5 for Ta -50°C to +40°C
II 2D Ex tD A21 IP 66 T125°C based on max. Ta of +70°C

Certificate No. KEMA 01ATEX2030

CE Marking
Notified Body No.

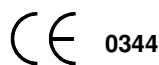

“Warnings” DO NOT OPEN WHEN AN EXPLOSIVE
GAS OR DUST ATMOSPHERE IS PRESENT

COVER BOLTS CLASS A4-80

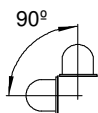

USE HEAT RESISTING CABLES AND CABLE GLANDS
(Rated 110°C) AT AMB. TEMPERATURES OVER 40°C

Year of Construction /
Serial No.

i.e. 09 / 3DB53000001

3) Type Approval Standards

The beacons have an EC Type examination certificate issued by KEMA and have been approved to the following standards:-

EN60079-0:2006	Gas General Requirements
EN60079-1:2007	Flameproof Enclosure 'd'
EN60079-7:2007	Increased Safety 'e'
EN61241-0:2006	Dust General Requirements
EN61241-1:2004	Dust Enclosures tD

4) Installation Requirements

The beacons must be installed in accordance with the latest issues of the relevant parts of the BS EN 60079 specifications or the equivalent IEC specifications – Selection, Installation and maintenance of electrical apparatus for use in potentially explosive atmospheres (other than mining applications or explosive processing and manufacture): -

EN60079-14:2008	Electrical Installations in Hazardous Areas (other than mines)
EN60079-10:2003	Classification of Hazardous Areas

The installation of the units must also be in accordance with any local codes that may apply and should only be carried out by a competent electrical engineer who has the necessary training.

5) Zones, Gas Group, Category, IP Rating and Temperature Classification

The BExBG15E and BExBG10E beacons have been certified Ex de IIC T4 for Ta -50°C to +70°C and Ex de IIC T5 for Ta -50°C to +40°C for gas and Ex tD A21 IP66 T125°C based on max. +70°C for dust. This means that the units can be installed in locations with the following conditions:-

Area Classification Gas:

Zone 1	Explosive gas air mixture likely to occur in normal operation.
Zone 2	Explosive gas air mixture not likely to occur, and if it does, it will only exist for a short time.

Gas Groupings:

Group IIA	Propane
Group IIB	Ethylene
Group IIC	Hydrogen and Acetylene

Temperature Classification:

T1	400° C
T2	300° C
T3	200° C
T4	135° C

T5	100° C	Amb. +40° C
----	--------	-------------

Area Classification Dust:

Zone 21	Explosive dust air mixture likely to occur in normal operation.
Zone 22	Explosive dust air mixture not likely to occur, and if it does, it will only exist for a short time.

IP Rating: IP66 T125°C $T_a \leq +70^\circ\text{C}$
 T110°C $T_a \leq +55^\circ\text{C}$
 T95°C $T_a \leq +40^\circ\text{C}$

Equipment Category: 2G/D

Ambient Temperature Range: -50°C to +70°C
 (T5 = +40°C)

6) Beacon Location and Mounting

The location of the beacons should be made with due regard to the area over which the warning signal must be visible. They should only be fixed to services that can carry the weight of the unit.

SAFETY WARNING: The BExBG15E and BExBG10E 15 and 10 joule beacons must be mounted with their flashdome in a position between upright and 90° as shown.

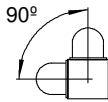

The beacons should be securely bolted to a suitable surface using the 7mm diameter boltholes in the stainless steel U shaped mounting bracket (see figure 1). The angle can then be adjusted as required but the mounting restrictions must be observed (see above). This can be achieved by loosening the two large bracket screws in the side of the unit, which allow adjustment in steps of 18°. On completion of the installation the two large bracket adjustment screws on the side of the unit must be fully tightened to ensure that the unit cannot move in service.

SAFETY WARNING: The flashdome guard must not be removed from the unit at any time.

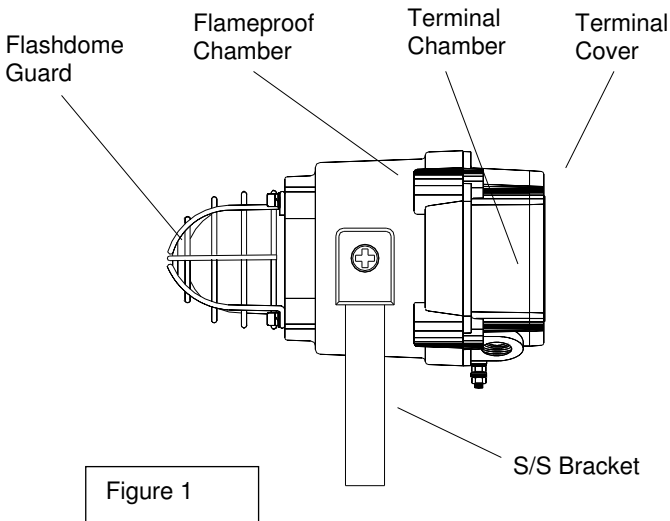

7) Access to the Flameproof Enclosure

For normal operation it will not be necessary to gain access to the flameproof chamber. The only time this will be necessary is when the unit is being set to flip-flop mode or the fitting of an end of line monitoring resistor on DC units. If access is necessary remove the four M6 hexagon socket head screws (see figure 2) and withdraw the flameproof cover taking extreme care not to damage the flameproof joints in the process.

Note the four **M6 screws are Class A4-80 stainless steel and only screws of this category can be used on the beacons.** It is therefore important that these screws and their spring washers are kept in a safe place during installation.

On completion of the output mode setting or the fitting of the end of line resistor, the flameproof joints should be inspected to ensure that they are clean and that they have not been damaged. Also check that the earth bonding wire between the two casting sections is secure and that the 'O' ring seal is in place. When replacing the terminal chamber section casting, ensure that it is square with the flameproof chamber casting before inserting. Carefully push the section in place allowing time for the air to be expelled. Only after the section is fully in place should the four M6 Stainless Steel A4-80 cover bolts and their spring washers be inserted and tightened down. If the section jams while it is being inserted, carefully remove it and try again. Never use the M6 cover bolts to force the cover into position.

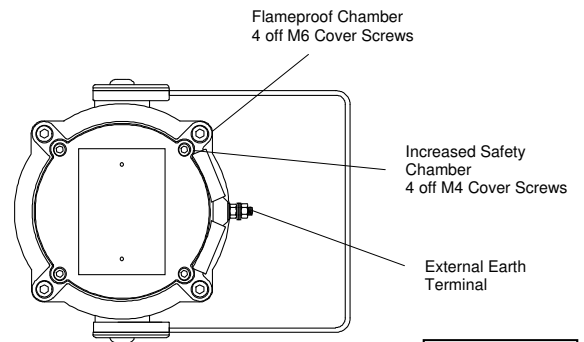
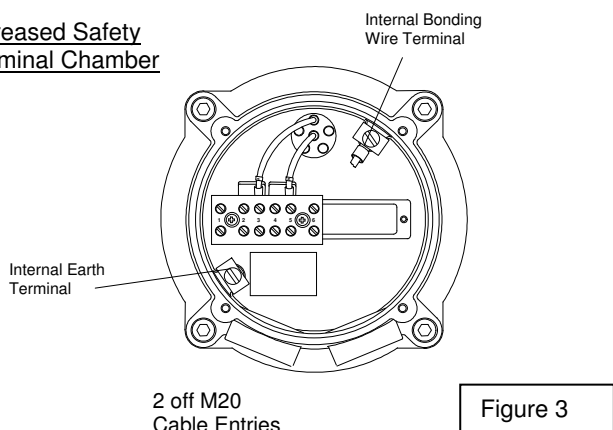

Figure 2

8) Access to the Increased Safety Terminal Chamber

To connect the input cables to the beacon it is necessary to remove the terminal cover to gain access to the termination chamber. To achieve this remove the four M4 hexagon socket head screws (see figure 2). The four M4 screws and their spring washers are grade A4 stainless steel and they should be kept in a safe place during installation. Before replacing the terminal cover ensure that the earth bonding wire between the two castings is secure and that the 'O' ring seal is in place. Insert the four M4 hexagon screws and their spring washers and tighten them down.

Increased Safety Terminal Chamber



11) Earthing

Both AC and DC beacon units must be connected to a good quality earth. The units are provided with internal and external earthing terminals which are both located on the terminal chamber section of the unit (see figures 2 and 3).

When using the internal earth terminal ensure that the stainless steel M4 flat washer is between the incoming earth wire and the enclosure.

When using the external earth terminal a cable crimp lug must be used. The cable lug should be located between the two M5 stainless steel flat washers. The M5 stainless steel spring washer must be fixed between the outer flat washer and the M5 stainless steel nut to ensure that the cable lug is secured against loosening and twisting.

The internal earth bonding wire ensures that a good quality earth is maintained between the flameproof chamber casting and the flameproof cover casting.

12) Cable Glands

The BExBG15E and BExBG10E beacons have dual cable gland entries which have an M20 x1.5 entry. Only cable glands approved for Ex 'e' applications or better (i.e. Ex 'd' applications, provided they have an IP rating of IP 54 or better) can be used. They must be suitable for the type of cable to be used and also meet the requirements of the Ex equipment installation standard EN 60079-14:2008.

When only one cable entry is used the other one must be closed with an Ex 'e' blanking plug, which must be suitably approved for the installation requirements.

For combustible dust applications, the cable entry device and blanking elements shall be in type of explosion protection increased safety "e" or flameproof enclosure "d" and shall have an IP 6X rating according to EN 60529:2000.

SAFETY WARNING: If the beacons are used at high ambient temperatures, i.e. over +40°C, then the cable entry temperature may exceed +70°C and therefore suitable heat resisting cable glands must be used, with a rated service temperature of at least 110°C.

13) Cable Connections

The cable connections are made into an Ex e II approved six way terminal block which is located in the Increased Safety Area terminal chamber (see figure 3). See section 8 of this manual for access to the terminal chamber. When wiring into Increased Safety Area terminal enclosures, you are only permitted to connect one wire into each way on the terminal block. Therefore in order that beacons can be connected in a parallel line, the terminal block is fitted with approved connecting combs so that each electrical connection has two terminals in parallel. Terminal No's. 1 and 6 must not be used on either AC or DC units. Cables with a cross-sectional area of up to 4mm² can be connected to the terminal block. Cables that have a small cross-sectional area should be fitted with crimp ferules.

9) Power Supply Selection

It is important that a suitable power supply is used to run the beacons. The power supply selected must have the necessary capacity to provide the input current to all of the beacons connected to the system.

The following table shows the input current taken by the various beacons:-

Unit Type	Nominal I/P Voltage	Input Current	Max. I/P
Volts			
BExBG15E	24V DC	860mA	30V
BExBG15E	48V DC	480mA	58V
BExBG15E	230V AC	170mA	253V
BExBG15E	115V AC	360mA	126V
BExBG10E	12V DC	1.45A	15V
BExBG10E	24V DC	660mA	30V
BExBG10E	48V DC	340mA	58V
BExBG10E	230V AC	110mA	253V
BExBG10E	115V AC	250mA	126V

The input current will vary according to the voltage input level. The current levels shown above are for nominal input voltage. The 12V, 24V and 48V DC units have a converter circuit and therefore the input current level will decrease slightly as the input voltage is increased and will increase slightly as the input voltage is reduced.

The above table also shows the maximum voltages at which the beacons can be operated.

10) Cable Selection

When selecting the cable size consideration must be given to the input current that each unit draws (see table above), the number of beacons on the line and the length of the cable runs. The cable size selected must have the necessary capacity to provide the input current to all of the beacons connected to the line.

SAFETY WARNING: If the BExBG15E and BExBG10E beacons are used at high ambient temperatures, i.e. over +40°C, then the cable entry temperature may exceed +70°C and therefore suitable heat resisting cables must be used, with a rated service temperature of at least 110°C.

The wiring connections to the beacons are as follows:-

Terminal No's	DC Units	AC Units
2 and 3	-ve	N
4 and 5	+ve	L

14) Synchronised Operation

All BExBG15E and BExBG10E beacons that are connected to the same supply line will have a synchronised flash rate at one flash every second.

15) Flip-Flop Operation

Two beacons can be mounted close to each other to form a flip-flop operation, where the beacons will flash alternately. To achieve this one beacon must be set so that the first flash is delayed by $\frac{1}{2}$ a second. To set this mode of operation the flameproof chamber must be accessed, (see section 7). The unit is set by fitting a pin header to the flip- flop header pins on the electronics board, i.e. the two header pins are shorted together (see figure 4), on one of the two beacons being used. The two beacons will then flash alternately every $\frac{1}{2}$ a second.

BExBG15E and BExBG10E 15 and 10 Joule Beacons Flameproof Enclosure

Flip / Flop
Terminal
Header

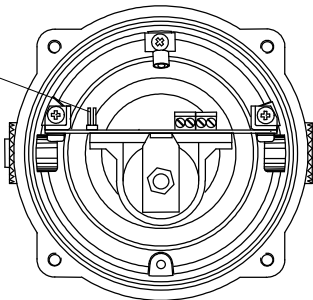

Figure 4

16) End of Line Monitoring (DC Units)

On the BExBG15E and the BExBG10E DC beacon units, dc reverse line monitoring can be used if required. All DC units have a blocking diode fitted in their supply input lines. An end of line monitoring diode or an end of line monitoring resistor can be connected across the +ve and -ve terminals in the flameproof chamber. **Note monitoring components must not be connected to the terminal block in the Increased Safety terminal chamber.** See section 7 of this instruction manual for access to the flameproof enclosure. If an end of line resistor is used it must have a minimum resistance value of 3k3 ohms and a minimum wattage of 0.5 watts or a minimum resistance value of 500 ohms and a minimum wattage of 2 watts.