

MANUAL

PMI360DV-F130-IU2E2-V15

Inductive angle positioning system



CE

With regard to the supply of products, the current issue of the following document is applicable: The General Terms of Delivery for Products and Services of the Electrical Industry, published by the Central Association of the Electrical Industry (Zentralverband Elektrotechnik und Elektroindustrie (ZVEI) e.V.) in its most recent version as well as the supplementary clause: "Expanded reservation of proprietorship"

1	Introduction.....	5
2	Declaration of conformity	6
3	Safety	7
3.1	Used Symbols	7
3.2	Intended use.....	7
3.3	General safety instructions	7
4	Product Description	8
4.1	Use and application	8
4.2	Displays and controls.....	9
4.3	Delivery package.....	9
4.4	Accessories	10
4.4.1	Connecting cable.....	10
4.4.2	Actuator	10
5	Installation.....	11
5.1	Note on safety	11
5.2	Mounting.....	11
5.3	Electrical connection.....	13
6	Commissioning.....	14
6.1	Programming the switching outputs.....	14
6.2	Programming the analog output	15
7	Output function in normal operation	17
7.1	Function of switching outputs S1 and S2.....	18
7.2	Function of the analog output I/U.....	18
8	Maintenance and Repair	20
8.1	Maintenance	20
8.2	Resetting the output functions to default.....	20



9 Troubleshooting..... 21
 9.1 Faults when programming the outputs 21
 9.2 Faults during operation..... 22

10 Disposal..... 23

1 Introduction

Congratulations

You have chosen a device manufactured by Pepperl+Fuchs. Pepperl+Fuchs develops, produces and distributes electronic sensors and interface modules for the market of automation technology on a worldwide scale.

Symbols used

The following symbols are used in this manual:



Note!

This symbol draws your attention to important information.



Handling instructions

You will find handling instructions beside this symbol

Contact

If you have any questions about the device, its functions, or accessories, please contact us at:

Pepperl+Fuchs GmbH
Lilienthalstraße 200
68307 Mannheim
Telephone: +49 621 776-4411
Fax: +49 621 776-274411
E-Mail: fa-info@pepperl-fuchs.com



2

Declaration of conformity

This product was developed and manufactured under observance of the applicable European standards and guidelines.



Note!

A Declaration of Conformity can be requested from the manufacturer.

The product manufacturer, Pepperl+Fuchs GmbH, D-68307 Mannheim, has a certified quality assurance system that conforms to ISO 9001.



3 Safety

3.1 Used Symbols

Safety-relevant Symbols



Danger!

This symbol indicates an imminent danger.
Non-observance will result in personal injury or death.



Warning!

This symbol indicates a possible fault or danger.
Non-observance may cause personal injury or serious property damage.



Caution!

This symbol indicates a possible fault.
Non-observance could interrupt the device and any connected systems and plants, or result in their complete failure.

Informative Symbols



Note!

This symbol brings important information to your attention.



Action

This symbol indicates a paragraph with instructions.

3.2 Intended use

The inductive angle positioning system PMI360DV-F130... was designed for position detection on valve actuators or valves. In addition to these main applications, the inductive angle positioning system PMI360DV-F130... is also suitable for the precision, non-contact detection of all movement sequences in applications where machine or system components rotate or swivel around an axis with a maximum diameter of 41.5 mm.

3.3 General safety instructions

Responsibility for planning, assembly, commissioning, operation, maintenance, and dismantling lies with the plant operator.

Installation and commissioning of all devices must be performed by a trained professional only.

User modification and or repair are dangerous and will void the warranty and exclude the manufacturer from any liability. If serious faults occur, stop using the device. Secure the device against inadvertent operation. In the event of repairs, return the device to your local Pepperl+Fuchs representative or sales office.



Note!

Disposal

Electronic waste is hazardous waste. When disposing of the equipment, observe the current statutory requirements in the respective country of use, as well as local regulations.

4 Product Description

4.1 Use and application

The inductive angular positioning system PMI360DV-F130-IU2E2-V15 is a measuring system designed for the non-contact detection of the angular position of valve actuators and valves. The system offers flexible, user-friendly parameterization functions and is suitable for the universal detection and feedback of rotary movements around a fixed rotation point in all areas of machine and plant construction.



The PMI360DV-F130-IU2E2-V15 has an analog output for the indication of angular positions. For high resistance loads ($>3.3 \text{ k}\Omega$), the angular position will output a voltage value $0 \dots 10 \text{ V}$ DC and for low resistance loads ($<400 \Omega$), a current value $4 \dots 20 \text{ mA}$. In addition, the PMI360DV-F130-IU2E2-V15 has two switching outputs that can be programmed independently of one another and that can be used to mark two important positions (e.g., start and stop position).

The actuator BT-F130-A (see chapter 4.4) is usually attached to the rotary system component to detect the position. This actuator rotates in the central hole on the PMI360DV-F130-IU2E2-V15, contains a metal insert required for position detection and is adapted perfectly to the mechanical requirements of valves or valve actuators.



Note!

In principle, the actuator BT-F130-A is not required. A damping element made from construction steel such as S235JR+AR or international equivalent, (previously St37-2) can be mounted on the rotary system component. This damping element must fulfill all requirements relating to the material, dimensions and distances to the inductive angular positioning system PMI360DV-F130... See chapter 5.2

4.2 Displays and controls

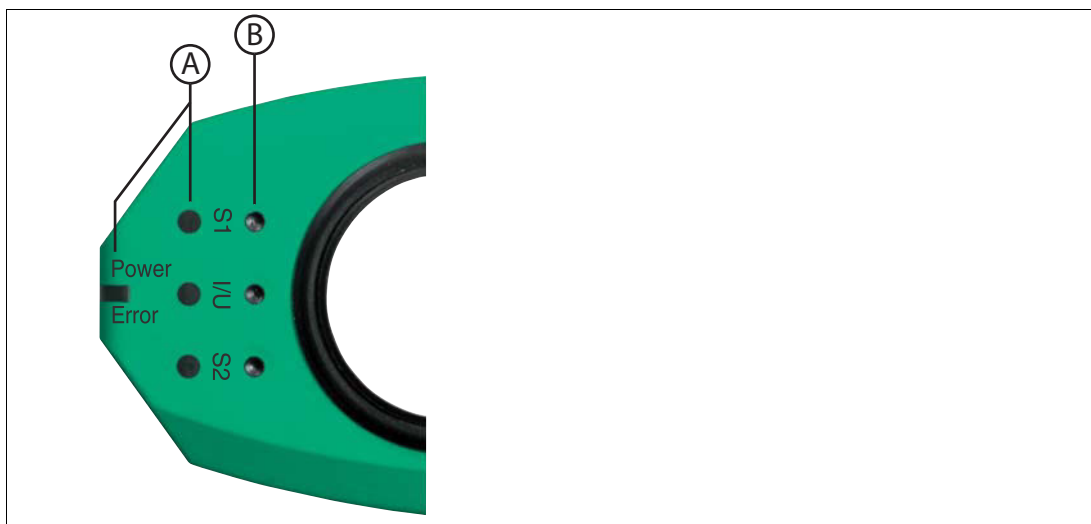

- A LED indicators**
- B Programming buttons**

4 LEDs and 3 programming buttons are located on top of the PMI360DV-F130-IU2E2-V15.

The central, front "Power/Error" LED is a 2-color LED that lights up or flashes green (normal operation) or red (fault) depending on the operating state of the device. The LEDs "S1", "S2" and "I/U" are yellow and indicate the status of the device during programming and normal operation.

The programming buttons are used to configure the angular positioning system. The central I/U button is used to configure the start and end points of the analog output and the outer "S1" and "S2" buttons are used to configure the start and end of the detection zone of the two switching outputs on the sensor.

The "S1", "S2" and "I/U" LEDs correspond to the "S1", "S2" and "I/U" programming buttons.

4.3 Delivery package

- PMI360DV-F130-IU2E2-V15
- Quick start guide



4.4 Accessories

Various accessories are available.

4.4.1 Connecting cable

You can use the following cables for the electrical connection:

M12 x 1 connectors, 5-pin

Figure	Material	Length	Order designation
	PVC	2 m 5 m 10 m	V15-G-2M-PVC V15-G-5M-PVC V15-G-10M-PVC
	PUR	2 m 5 m 10 m	V15-G-2M-PUR V15-G-5M-PUR V15-G-10M-PUR
	PVC	2 m 5 m 10 m	V15-W-2M-PVC V15-W-5M-PVC V15-W-10M-PVC
	PUR	2 m 5 m 10 m	V15-W-2M-PUR V15-W-5M-PUR V15-W-10M-PUR

Different lengths on request. Also available are shielded cables that may be used in electrically noisy installation environments.

4.4.2 Actuator

The BT-F130-A actuator is designed for mounting directly on the drive shaft or a servodrive.



5 Installation

5.1 Note on safety



Warning!

Risk of short circuit

Injuries and damage to the device are possible when working with live parts.

- Before working on the device, always disconnect the supply voltage.
- Connect the device to the supply voltage only after completion of the work.

5.2 Mounting

Mount the sensor as follows:



Mounting

1. Place the sensor on a stable mounting bracket or another suitable base.
2. Align the sensor so that the axis of rotation to be detected is centered on the housing bore hole.
3. Fix the sensor by means of two cylinder head bolts M5 (thread length ≥ 20 mm).
4. Check for rigid and stable seating of the sensor.
5. Mount the actuator or a self-made actuation element on the rotation shaft (if not already mounted) .
6. Check for the required actuator dimensions and gap distance between sensor and actuator. The actuator must not make physical contact or scratch the sensors surface when moving.

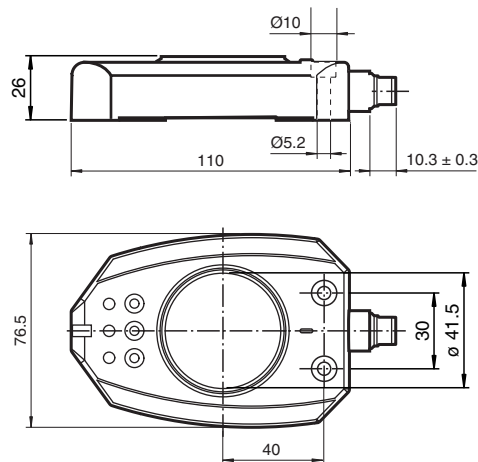

Using a different actuating element

You may use a different actuator instead of the BT-F130-A actuator provided. When using a different actuating element, the element must fulfill all requirements relating to the material, dimensions and distance to the sensitive surface on the sensors (see table). Failing to fulfill all of these requirements may reduce the accuracy/resolution of the sensor or even cause the sensor to stop functioning.

Dimensions when using a different actuating element

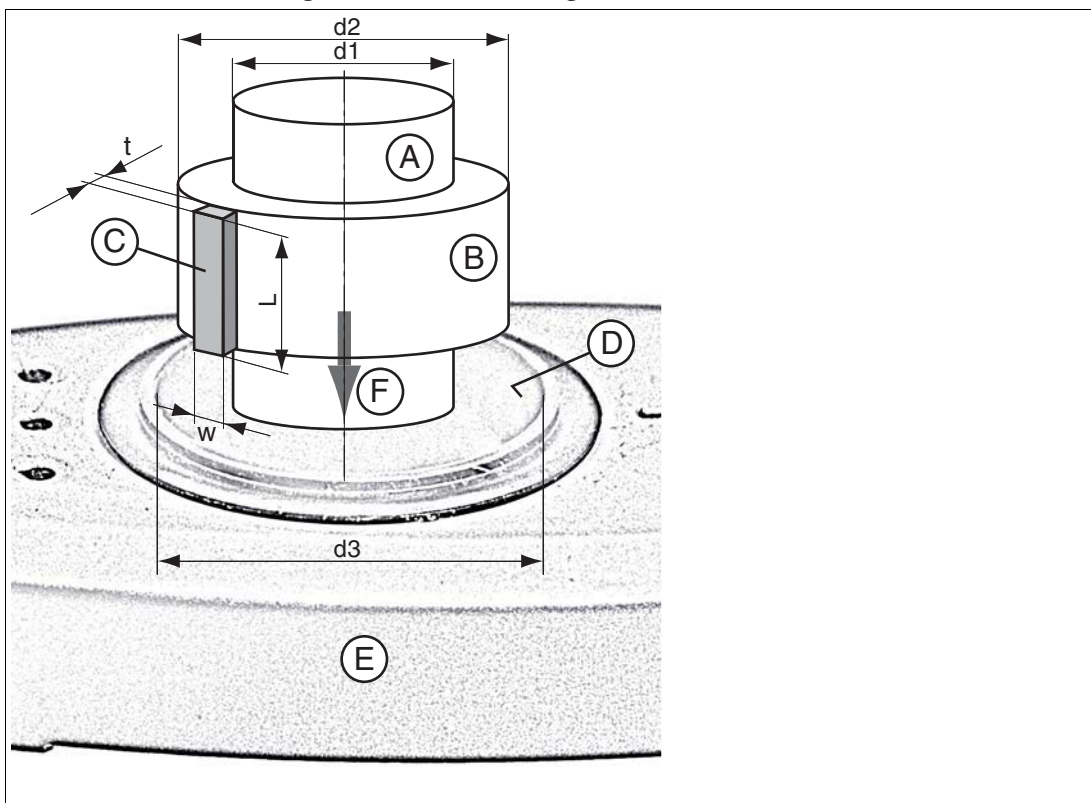

- A Drive shaft**
- B Insulation ring made from non-conductive material**
- C Separate actuator (L ≥ 23 mm)**
- D Sensitive surface on the sensors (black, cylindrical inner surface)**
- E Sensor**
- F Insert the shaft until actuator C and the sensitive surface on sensor D overlap as far as possible.**

Actuator (C) can be placed on the insulating ring made from non-conductive material (B) or inserted in this ring.

Dimension	Value
t	2 mm
w	7.5 mm
d1	Depending on the drive shaft material S235JR+AR (previously St37-2): max. 19 mm Stainless steel 1.4435 / AISI 316L (V4A): max. 21 mm Stainless steel 1.4305 / AISI 303 (V2A): max. 23 mm
d2	Select so that the distance between the edges of the actuator and the sensitive surface on the sensor is 1 ... 2 mm.
d3	41.5 mm
Actuator material	Construction steel such as S235JR+AR (previously St37-2)

5.3 Electrical connection

Wire the electrical connections on the sensor as follows:



Electrical connection

1. For the electrical connection to the sensor, use one of the cordsets with a 5-pin connector M12 x 1 listed in the Accessories chapter.
2. When routing the electric cables, make sure they are protected against physical damage.
3. Make sure that cables are routed at a sufficient distance from other current-carrying system components. This is the only way to guarantee adequate protection from short circuits and/or interfering signals. If required shielded cables can be used to help prevent electrical interference.
4. Check that the wires are connected correctly before connecting the cordset to the sensor. On Pepperl+Fuchs cordsets, the wire colors are assigned to the connecting pins in the connector according to DIN EN 60947-5-2.
5. Attach the socket on the cordset to the connector on the sensor and tighten the union nut by hand.
6. Switch on the operating voltage.
 - ↳ The "Power/Error" LED on the sensor lights up green if the actuator is already fitted and red if the actuator is not yet fitted.



Note!

Other LEDs may light up depending on the position of the actuator.

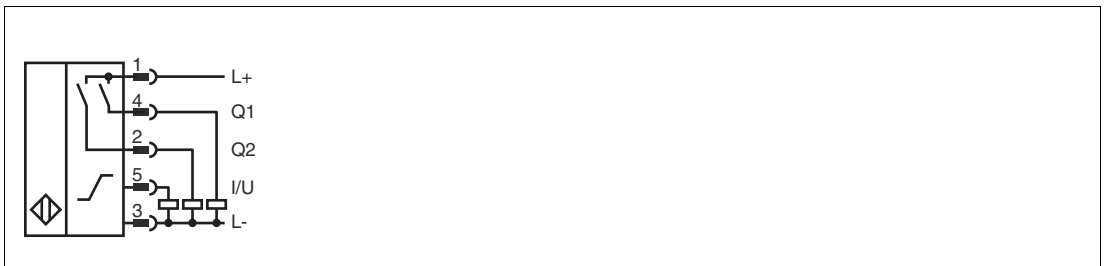

Connector pin	Function
1	+U _B
2	Switching output Q2 (detection zone S2)
3	-U _B
4	Switching output Q1 (detection zone S1)
5	Analog output I/U

Wire colors are assigned to the connecting pins in the connector according to DIN EN60947-5-2.

Connecting pin	Wire color
1	brown
2	white
3	blue
4	black
5	gray

6 Commissioning

6.1 Programming the switching outputs

2 switching zones with a zone width of 5° are preset at the factory. The switching zones lie between the angle settings 120°... 125° (S1) and 240° ... 245° (S2). You can modify the position and width of these switching zones by programming them accordingly. The start and end points of a switching zone can be defined at any position. The smallest angle range of a switching zone can be 5° and the largest angle range of a switching zone 360°.



Note!

Unlocking the buttons

If the keylock is active, it must first be deactivated. The sensor indicates that the keylock is active by changing the color of the "Power/Error" LED to red when a button is pressed. To unlock the buttons, press and hold the S1 and S2 buttons simultaneously for 3 seconds. The color of the "Power/Error" LED changes to green. The buttons are no longer locked.

Program switching output 1 (S1) as follows:



Programming switching output S1

1. Make sure that the sensor is mounted correctly and securely, and check that an actuator with the specified dimensions is positioned at the correct distance from the surface of the sensor. See chapter 5.2
2. Unlock the keyboard, if locked. See "Unlocking the buttons" on page 14
3. Press the S1 button for ≥ 2 s.
 - ↳ The flashing yellow LED indicates that the device is ready for you to teach in the signaling zone start point.
4. Move the actuator to the position that you wish to define as the start point of the signaling zone. Press the S1 button again.
 - ↳ The yellow S1 LED lights up for 2 seconds and then starts to flash again. This indicates that the device is ready for you to teach in the signaling zone end point.
5. Move the actuator to the position that you wish to define as the signaling zone end point. **The rotation direction of the actuator is decisive here. At the end of programming, the area covered by the actuator will be the angle range in which the switching output is active.**
6. Briefly press the S1 button.
 - ↳ The setting is then stored in the non-volatile memory of the sensor. The yellow LED then lights up permanently to indicate that programming was successful.



Note!

If the actuator does not move between the time the signaling zone start and end points are programmed, the smallest possible signaling zone is programmed with a width of 5°. The signaling zone start point is then set at the programmed position.



Note!

If interrupted for more than 1 minute, the programming process is terminated. The sensor continues operating with unchanged values.



Note!

The programming process is terminated if any button is pressed other than the correct button. The sensor continues operating with unchanged values.

Programming switching output S2

The switching output 2 (S2) is programmed in the same way. Press the S2 button. The S2 LED indicates the status.



Note!

Activating the keylock

The keylock is not activated initially. Press any button on the sensor briefly to determine whether the keylock is active. If the color of the "Power/Error" LED remains green, the keylock is inactive and if the color of the "Power/Error" LED changes to red, the keylock is active. To activate the keylock, press and hold the S1 and S2 keys simultaneously for 3 seconds. The color of the "Power/Error" LED changes to red.

6.2 Programming the analog output

The start point of the analog output is preset to the angular position 0° and the end point is preset to the angular position 360° in the factory. If the actuator is located in the 0° position, a current value of 4 mA or a voltage value of 0 V is available at the analog output depending on the connected load. If the actuator is rotating clockwise, the output value increases proportionately according to the angle until the analog output adopts the maximum value of 20 mA or 10 V after reaching the angular position 360°. The start and end points of the analog output can be programmed at any desired position. The permitted limited values of the angle range for the analog output are 45° and 360°.



Note!

A loss of the actuator during the programming process interrupts the programming process and a fault message is issued. The last valid parameters are retained.

Program the analog output as follows:



Programming the analog output

1. Make sure that the sensor is mounted correctly and securely, and check that an actuator with the specified dimensions is positioned at the correct distance from the surface of the sensor. See chapter 5.2
2. Press the "I/U" button for ≥ 2 s.
 - ↳ The flashing yellow LED indicates that the device is ready for you to teach in the start point of the analog ramp.
3. Move the actuator to the position that you wish to define as the start point of the analog ramp and then press the "I/U" button.
 - ↳ The yellow "I/U" LED lights up for 2 seconds and then starts to flash again. This indicates that the device is ready for you to teach in the end point of the analog ramp.
4. Move the actuator to the position that you wish to define as the end point of the analog ramp.

When the actuator rotates, the first 30° define the direction of rotation of the measurement range in which the values of the analog output increase (clockwise/counterclockwise). If the actuator rotates less than 30°, the previously set direction of rotation is retained.
5. Briefly press the "I/U" button.
 - ↳ The setting is then stored in the non-volatile memory of the sensor. The yellow "I/U" LED then lights up permanently to indicate that programming was successful.

When the actuator moves in a clockwise or counterclockwise direction, the analog output value increases starting from the programmed start position, depending on the direction in which the actuator moves during the programming process. The overall signal range 4 ... 20 mA or 0 ... 10 V of the analog output is scaled to the programmed angle segment.



Note!

Programming an angle segment of exactly 45°

If you intend to program an angle segment of exactly 45° for the analog output, you can make use of the restriction that prevents the angle segment from being below 45°
 In the second step of the angle segment programming process, move the actuator to a position that represents less than 45° in relation to the start position. If the actuator covers an angle < 30°, the preset direction of rotation is retained. If the actuator covers an angle > 30° but < 45°, this direction of rotation is adopted.
 After the relevant button is pressed to confirm this position, the sensor calculates and stores the exact position value for 45°.



Note!

Programming an angle segment of exactly 360°

If you intend to program an angle segment of exactly 360° for the analog output, you can make use of the restriction that prevents the angle segment from exceeding 360°.
 In the second step of the angle segment programming process, move the actuator to a position that represents more than a full rotation in relation to the start position (>360°, but <390°). The direction of the rotation movement determines the direction in which the output values of the analog output increase.
 If the actuator does not move between the time the measurement range start point and end point are parameterized, a measurement range of 360° is programmed. The measurement range start point is then located in the position defined in the first step. The previous preset direction of rotation for increasing the output values is retained in this case.
 After the relevant button is pressed to confirm this position, the sensor independently calculates and stores the exact position value for 360°.

7 Output function in normal operation

Example

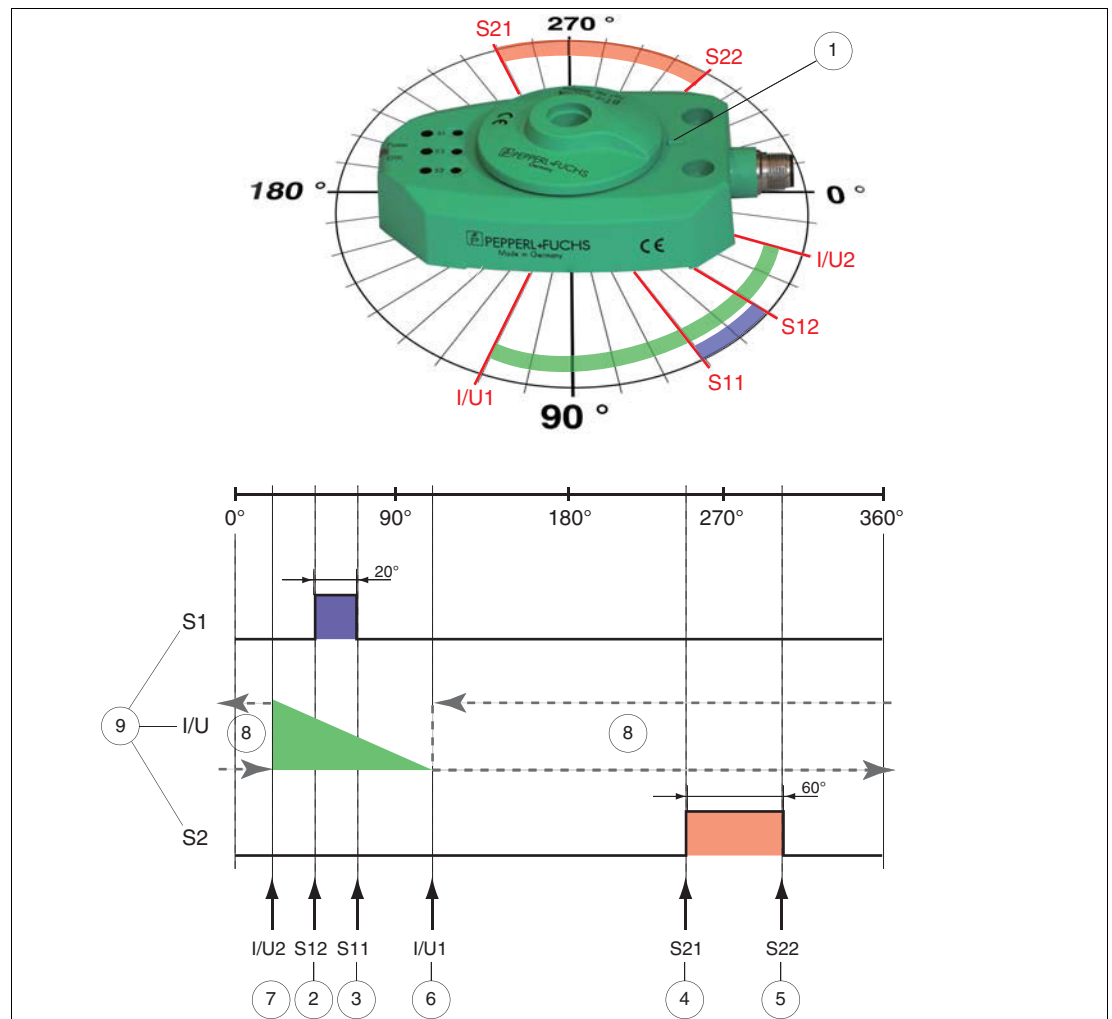

Figure 7.1 Output function depends on the position of the actuator and the method used to program the outputs.

1. Marking for angle position 0° (default setting is analog output I/U)
2. Position of the second switching point of switching output S1 (example 40°)
3. Position of the first switching point of switching output S1 (example 60°)
4. Position of the first switching point of switching output S2 (example 250°)
5. Position of the second switching point of switching output S2 (example 310°)
6. Start position of analog output S3 (example 20°)
7. End position of analog output S3 (example 110°)
8. Angular range outside of analog measurement range. The function of the analog output depends on whether the output assumes the function of a voltage or a current output (depending on the load). See chapter 4.1

Current output:

If the measurement range is exceeded, the analog output value adopts the error signal 3.6 mA. The current output issues this fault current until the position of the actuator falls within the programmed analog measurement range again.

Voltage output:

If the measurement range is exceeded, the analog output value retains the last displayed value until the position of the actuator falls within the analog measurement range again (shown in the example).

9. Output signals

7.1 Function of switching outputs S1 and S2

The position of the actuator defined by the angular positioning system is based on half of the actuator width (center of the actuator). The signaling zones are preset to the angle settings 120°... 125° (S1) and 240° ... 245° (S2) at the factory. The switch-on and switch-off points of the signaling zone can be programmed at any desired position. However, the minimum signaling zone width is 5°.

If the actuator falls between S11 and S12 or S21 and S22 in the programmed signaling zone, the corresponding switching output is activated. When a switching output is active, the corresponding yellow LED lights up. If the actuator is positioned outside of a programmed signaling zone, the relevant switching output changes to an idle state. When the actuator leaves the detection area of the angular positioning system (loss of actuator), an active switching output changes to an idle state ("up" position) and a switching output already in an idle state remains in this state. The "Power/Error" LED lights up red when the actuator is lost.

7.2 Function of the analog output I/U

Function in normal operation

The position of the actuator defined by the angular positioning system is based on half of the actuator width (center of the actuator). The start point of the analog output is preset to the angular position 0° and the analog measuring range is set to a full 360° in the factory. The start and end points of the analog measuring range can be defined by programming each relevant angular position, the only restriction being that the analog measurement range must fall between 45° and 360°.

After switching on, the angular positioning system automatically evaluates the load connected at the analog output. If the load is a low resistance load (<400 Ω), the analog output assumes the function of a current output 4 ... 20 mA. If the load is a high resistance load (>3.3 kΩ), the analog output assumes the function of a voltage output 0 ... 10 V. A change in the load properties during operation is not evaluated.



Caution!

Make sure that the connected load is always low resistance ($\leq 400 \Omega$) or high resistance ($\geq 3.3 \text{ k}\Omega$).

If a load is connected with an impedance between 400 Ω and 3.3 kΩ, this may result in undefined output values because the sensor cannot fully control the analog output. The function of the output (current or voltage output) is not defined either.

The analog output shows the minimum value of the relevant value range (4 mA or 0 V) at the start position (I/U1). If the actuator rotates towards the programmed end position (I/U2), the output value increases proportionally in relation to the rotation angle covered. When the programmed end position is reached (I/U2), the analog output shows its maximum value (20 mA or 10 V). If the actuator moves within the area of the programmed measurement range, the corresponding yellow LED lights up. If the actuator rotates beyond the limits of the programmed measurement range, the LED goes out. The function of the output depends on whether the analog output assumes the function of a voltage or a current output.

Current output:

If the measurement range is exceeded, the analog output value adopts the error signal 3.6 mA. The current output delivers this fault current until the position of the actuator falls within the programmed analog measurement range again.

Voltage output:

After the measurement range is exceeded, the analog output value retains the last displayed value until the position of the actuator falls within the analog measurement range again (depending on the rotation direction, i.e. 0 V or 10 V).

When the position falls within the programmed measurement range again, the output value is updated according to the position of the actuator and adopts the programmed function.

Function when actuator is lost

If the actuator leaves the detection range of the angular positioning system (e.g. actuator is removed), the function of the output depends on whether the analog output assumes the function of a voltage or a current output.

Current output:

The output current retains the last valid value for 0.5 seconds. The output current then switches to a value of 3.6 mA in order to signal a fault. This current value is output until the actuator falls within the detection range of the angular positioning system again and the output value is updated.

Voltage output:

The output voltage retains the last valid value. This value is output until the actuator falls within the detection range of the angular positioning system again and the output value is updated.

8 Maintenance and Repair

8.1 Maintenance

The sensor's transmission properties are stable over long periods. For this reason, regular adjustments to, and maintenance on the sensor itself, are not necessary. Nevertheless check in the course of normal maintenance intervals that the sensor, the actuator and the connector are securely attached. Also check that the connecting cable is intact and correctly routed.

8.2 Resetting the output functions to default

The resetting process for each individual output is initiated using the buttons on the sensor. If the keylock is active, it must be deactivated before the functions can be reset to default.



Note!

Unlocking the buttons

If the keylock is active, it must first be deactivated. The sensor indicates that the keylock is active by changing the color of the "Power/Error" LED to red when a button is pressed. To unlock the buttons, press and hold the S1 and S2 buttons simultaneously for 3 seconds. The color of the "Power/Error" LED changes to green. The buttons are no longer locked.

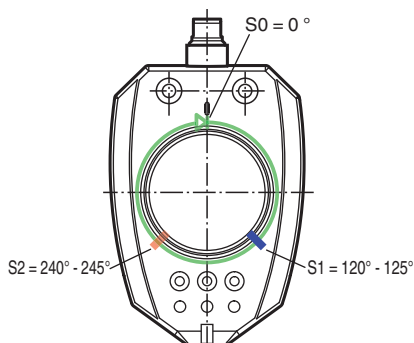

Default setting PMI360DV-F130-IU2E2-V15



Reset process

1. Press and hold the sensor button assigned to the output that you would like to reset.
 - ↳ The associated yellow LED starts to flash slowly after 2 seconds.
2. Continue to hold the sensor button.
 - ↳ The LED begins to flash more quickly after an additional 10 seconds.
3. Then release the button within 3 seconds.
 - ↳ The selected output is subsequently reset to default.



Note!

If a button is pressed and held for more than 15 seconds, the associated LED starts to flash slowly again. The "Power/Error" LED then flashes red at the same time. This fault signal indicates that a button is stuck. A reset to default does not occur in this case. As soon as the button is released, the "Power/Error" LED stops flashing red and lights up green permanently.

9 Troubleshooting

9.1 Faults when programming the outputs

If unexpected situations occur when the outputs of the inductive angular positioning system are programmed, refer to the table below for possible causes and instructions for rectifying the problem.

State	Possible cause	Action
The buttons do not unlock.	Buttons S1 and S2 not pressed long enough.	Press the buttons ≥ 3 seconds to unlock the buttons (see chapter 6.1).
Sensor cannot be moved in programming mode. The "Power/Error" LED lights up red when a button is pressed.	Keylock is activated.	Unlock the buttons (see chapter 6.1 or)
Sensor cannot be moved in programming mode (relevant yellow LED does not flash when a button is pressed).	Button not pressed long enough.	Press the button for programming the output ≥ 2 s.
Sensor cannot be moved in programming mode ("Power/Error" LED lights up red).	No actuator available or own actuator mounted too far away from the surface of the sensor.	Mount actuator according to specifications (see chapter 5.2).
"Power/Error" LED lights up red during programming.	Actuator lost during the parameterization process or distance between actuator and surface of sensor too great (own actuator).	Make sure that the concentricity and adjustment of own actuator does not result in a loss of the actuator (see chapter 5.2).
LED stops flashing during the programming process.	Timeout while programming the output (1 minute after the last input).	Move sensor again in programming mode (see chapter 6.1 or)
After programming, the function of the output/outputs remains unchanged.	Programming process not completed within the time frame (1 minute) or incorrect button pressed during programming.	Complete the programming process by pressing the corresponding button for the output a third time within the time frame (see chapter 6.1 or)
A yellow LED flashes and the "Power/Error" LED flashes red at the same time.	The button assigned to the flashing yellow LED is stuck.	Remove any dirt or foreign objects that are causing the key to stick.

9.2 Faults during operation

If the inductive angular positioning system does not function correctly, refer to the table below for possible causes and instructions for rectifying the problem.

Error	Possible cause	Action
"Power/Error" LED does not light up	The power supply is switched off.	Check whether there is a reason for it being switched off (installation or maintenance work etc.). Switch the power supply on if appropriate.
	The cordset is not connected to the connector on the sensor.	Connect the cordset to the sensor and tighten the union nut by hand.
	Wiring fault in the splitter or control cabinet.	Check the wiring carefully and repair any wiring faults.
	Supply cable to the sensor is damaged.	Replace the damaged cable.
"Power/Error" LED lights up red permanently or intermittently.	No actuator in the detection area of the sensor or unreliable detection of the actuator.	Check that the actuator used is mounted correctly or install an actuator with appropriate dimensions at the correct distance from the sensor. (see chapter 5.2).
Analog current output yields a value of approx. 3.6 mA	No actuator in the detection area of the sensor or unreliable detection of the actuator.	Check that the actuator used is mounted correctly or install an actuator with appropriate dimensions at the correct distance from the sensor. (see chapter 5.2).
	Actuator outside of parameterized measurement range.	Check that the position of the parameterized measurement range is correct.
Analog output does not reach the maximum value	Sensor operating voltage too low or load impedance out of specification.	Check the operating voltage of the sensor. Ensure that the load impedance is within the specified limits.
No output signal at the switching output even though the associated LED lights up	Output cable not connected	Connect the output cable
	Output cable is short circuiting	Rectify the short circuit
Output signal outside the value range specified at the analog output	Load connected only after the sensor is switched on	Disconnect the sensor from the supply voltage. Switch on the sensor again with the load connected.
Switching output signal "chatters"	Use of a different actuator with incorrect dimensions or an incorrect distance to the sensor	Install an actuator according to specifications ()
Output signal unstable or unreliable	Actuator rotating too quickly	Make sure that the speed of the actuator is ≤ 100 rotations/minute



10 Disposal

Electronic waste is hazardous waste. When disposing of the equipment, observe the current statutory requirements in the respective country of use, as well as local regulations.

The device does not contain any batteries that require separate disposal.

FACTORY AUTOMATION – SENSING YOUR NEEDS



Worldwide Headquarters

Pepperl+Fuchs GmbH
68307 Mannheim · Germany
Tel. +49 621 776-0
E-mail: info@de.pepperl-fuchs.com

USA Headquarters

Pepperl+Fuchs Inc.
Twinsburg, Ohio 44087 · USA
Tel. +1 330 4253555
E-mail: sales@us.pepperl-fuchs.com

Asia Pacific Headquarters

Pepperl+Fuchs Pte Ltd.
Company Registration No. 199003130E
Singapore 139942
Tel. +65 67799091
E-mail: sales@sg.pepperl-fuchs.com

www.pepperl-fuchs.com

 **PEPPERL+FUCHS**
SENSING YOUR NEEDS

Subject to modifications
Copyright PEPPERL+FUCHS • Printed in Germany

/ DOCT-1863B
06/2015