



TXMINI-M12 TRANSMITTER – OPERATING MANUAL – V1.0x E

INTRODUCTION

The TxMini-M12 Transmitter is a 4-20 mA 2-wires temperature transmitter for head mount, powered by the current loop. Its configuration is accomplished by connecting the TxConfig-M12 interface configuration. The configuration does not require that the transmitter be powered.

The output current is linearized according to the selected input sensor and adjusted to the configured range.

SPECIFICATIONS

Sensor Input: User defined. The supported sensors are listed in Table 1, along with their maximum ranges.

Pt100: Type 3-wire, Excitation 0.8 mA, $\alpha= 0.00385$, according IEC 60751 (ITS-90).

Pt1000: Type 3-wire, Excitation 0.8 mA, $\alpha= 0.00385$, according NBR 13773. IEC 60751 (ITS-90).
For 2-wire sensors, tie terminals 3 and 4 together.

Switch-on delay: < 2.5 s. The accuracy is only guaranteed after 15 min.

Terms of reference: ambient: 25 ° C; voltage: 24 Vdc, load: 250 Ω; settling time: 10 minutes.

Temperature Effect: < ± 0.2 % / 25 ° C

Response time: typical 1.6 s

Maximum voltage allowed at input terminals no sensor: 3 V.

RTD current: 800 μA.

RTD cable resistance effect: 0.005 °C / Ω.

Maximum allowable cable resistance for RTD: 25 Ω.

Sensor Type	Typical Accuracy	Minimum Accuracy
Pt100 / Pt1000	0.1%	0.2 %

Table 1 – Calibration error, percentage of the full measurement range

Power supply influence: 0.006 % / V typical (percentage of the full measure range).

Output: 4-20 mA or 20-4 mA current, 2-wire; linear in relation to the temperature measurement by the selected sensor.

Output Resolution: 2 μA.

Power supply: 8 to 35 Vdc, across the transmitter;

Maximum load (RL): $RL (max.) = (Vdc - 8) / 0.02 [\Omega]$
Where: Vdc= Power supply voltage (8-35 Vdc)

Operating Temperature: -40 to 85 ° C

Humidity: 0 to 90 % RH

Electromagnetic Compatibility: EN 61326-1:2006

No electrical isolation between input and output.

Internal protection against polarity inversion.

Cold junction compensation for thermocouples.

Connection Wire Cross Section: 0.14 a 1.5 mm²

Screw Tightening: 0.8 Nm.

Housing: Polyamide.

Sensor Type	Maximum Measurement Range	Minimum Measurement Range
Pt100	-200 to 650 °C	40 °C
Pt1000	-200 to 650 °C	40 °C

Table 2 – Sensors accepted by the transmitter

Order Codes:

- P/N: **8806060406:** TxMini-M12 transmitter;
- P/N: **8816021079:** TxConfig-M12 Interface.

CONFIGURATION

The sensor offset can be adjusted through the **TxConfig II** software. The USB cable may be connected to the transmitter without causing any measurement errors.

The user must select the sensor and most suitable range to the process. The chosen range must not exceed the maximum range specified for that sensor and should not be narrower than the minimum range for that same sensor.

It is important to note that the transmitter accuracy is based on the maximum range of the sensor used, even when a narrower range is programmed. Example:

- The Pt100 input has a max. range of -200 to +650 °C. Its accuracy is 0.2 % of the full range, resulting in a maximum allowed error of 1.7 °C (0.2 % of 850 °C).
- This error may be present even when a narrower range is configured for the sensor (for example: 0 to 100 °C.).

Note: When Pt100 simulators are used with the transmitter, make sure the excitation current of the simulator is compatible with the Pt100 excitation current of the transmitter, which is 0.8 mA.

The communication interface TxConfig-M12 is not electrically isolated from the transmitter's input.

SOFTWARE CONFIGURATION:

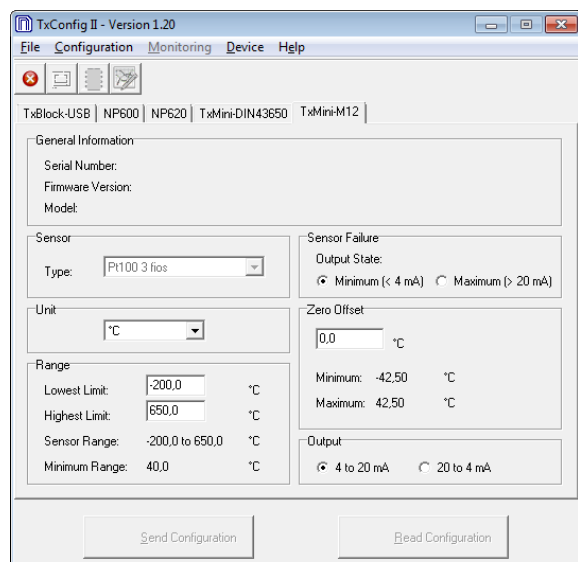

Fig. 1 – TxConfig II software main screen

The fields in the screen mean:

1. **General Information:** This field shows information that identifying the transmitter. This information should be sent to the manufacturer in an eventual request for technical assistance.

2. **Sensor:** Select the type of sensor to be used. See **Table 1**.

3. **Measuring Range:** Sets de measurement range of the transmitter.

Lower Range Limit: equivalent temperature for a current of 4 mA.

Upper Range Limit: equivalent temperature for a current of 20 mA.

Sensor Range

The values chosen cannot exceed the **range of sensor** shown in this field. See **Table 1** of this manual.

Minimum Range

Do not set a lower band (span) that the **Minimum Range** indicated below in this same field. See **Table 1** of this manual.

4. **Sensor Failure:** It establishes the output behavior, when the transmitter indicates a failure:

Minimum: output current goes to < 3.8 mA (down-scale), typically used for refrigeration.

Maximum: output current goes to > 20.5 mA (up-scale), typically used for heating.

5. **Zero Correction:** It corrects small deviations presented in the transmitter output, for example, when the sensor is replaced.

6. **Send Configuration:** It applies the new setup. Once sent, the setup will be immediately adopted by the transmitter.

7. **Read Configuration:** Reads the current setup in the transmitter connected. The screen now presents the current setup that may be changed by the user.

FACTORY SETTING:

- Sensor: Pt100 3-wire, range 0 to 100 °C
- Sensor failure: upscale (maximum).
- 0 °C zero correction.
- Unit: °C;
- Output: 4 to 20 mA.

Upon purchase order, the user can define a specific setup.

MECHANICAL INSTALLATION

TxMini-M12 Transmitter was designed to be installed in tubes and other small places. Vibrations, moisture and extreme temperatures, electro-magnetic interference, high voltage and other interferences can permanently damage the unit, and could cause error in the measured value.

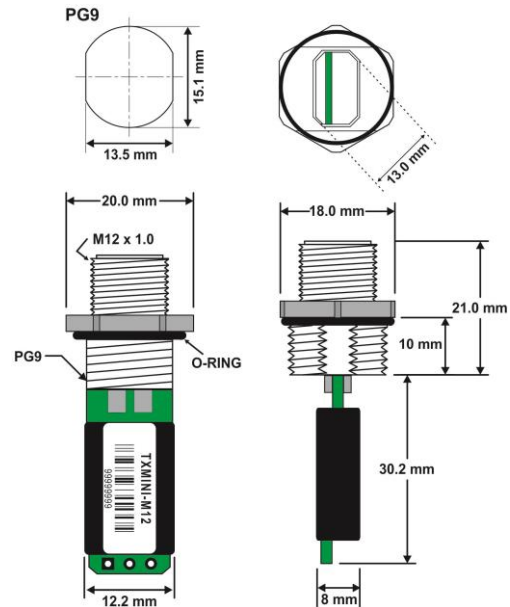

Fig. 2 – Dimensions of the transmitter

ELECTRICAL INSTALLATION

- Polyamide enclosure.
- Section of the cable used: 0.14 to 1.5 mm²

RECOMMENDATIONS FOR INSTALLATION

- Sensor signals conductors must go through the plant system separate from power leads (loop), if possible in grounded conduits.
- The instruments must be powered from the instrumentation power supply circuit.
- In control and monitoring applications is essential to consider what can happen when any part of the system fails.
- It is recommended the use of suppressors in contact coils, solenoids and any inductive load.

POWER AND COMMUNICATION CONNECTION

Terminal 2 is used to communicate with the product (TxConfig-M12 interface must be used).

Terminal 4 can be connected to cable shield, if needed.

	1	LOOP +
	2	COMM
	3	LOOP -
	4	SHIELD

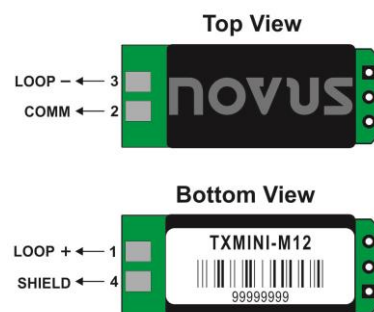

Fig. 3 – Output 4-20 mA

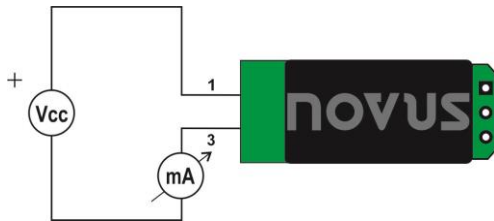

Fig. 4 – TxMini-M12 Connection Diagram

SENSOR CONNECTION

Terminals 1, 2 and 3 are dedicated to sensor connection. Terminals 1 and 2 must be shorted, as shown in the figure below.

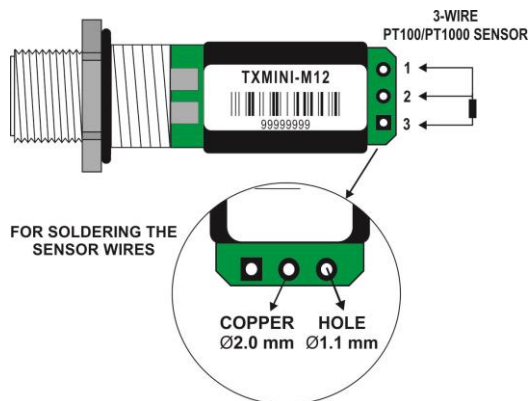

Fig. 5 – Input 3-wire Pt100/Pt1000

For appropriate cable resistance compensation, the same cable type should be used for all terminals. Maximum wire resistance is 25 Ω . Usage of a 3 or 4 wire with conductors of equal length and gauge is recommended.

OPERATION

The sensor offset can be adjusted through the **TxConfig II** software. The USB cable may be connected to the transmitter without causing any measurement errors.

The user must select the sensor and most suitable range to the process. The chosen range must not exceed the maximum range specified for that sensor and should not be narrower than the minimum range for that same sensor.

It is important to note that the transmitter accuracy is based on the maximum range of the sensor used, even when a narrower range is programmed. Example:

- The Pt100 input has a max. range of -200 to $+650$ $^{\circ}\text{C}$. Its accuracy is 0.2 % of the full range, resulting in a maximum allowed error of 1.7 $^{\circ}\text{C}$ (0.2 % of 850 $^{\circ}\text{C}$).
- This error may be present even when a narrower range is configured for the sensor (for example: 0 to 100 $^{\circ}\text{C}$).

Note: When Pt100 simulators are used with the transmitter, make sure the excitation current of the simulator is compatible with the Pt100 excitation current of the transmitter, which is 0.8 mA.

WARRANTY

Warranty conditions are on our web site www.novusautomation.com.