



# TxBlock-USB Transmitter

TEMPERATURE TRANSMITTER - OPERATING MANUAL – V1.0x G

## INTRODUCTION

The TxBlock-USB is a 4-20 mA 2-wire temperature transmitter for head mount, powered by the current loop. The output current is linearized and adjusted in function of the input sensor type and range configured.

Its configuration is accomplished by connecting the transmitter to a PC USB port without the need of any dedicated interface. The configuration does not require that the transmitter be powered.

## SPECIFICATIONS

**Sensor input:** User defined. The supported sensors are listed in Table 1, along with their maximum ranges.

**Thermocouples:** Types J, K, R, S, T, N, E and B according to IEC 60584 (ITS-90). Impedance >> 1 MΩ

**Pt100:** Type 3-wire, Excitation 0.8 mA,  $\alpha = 0.00385$ , according IEC 60751 (ITS-90).  
For 2-wire sensors, tie terminals 3 and 4 together.

**Pt1000:** Type 3-wire, Excitation 0.17 mA,  $\alpha = 0.00385$ , according IEC 60751 (ITS-90).  
For 2-wire sensors, tie terminals 3 and 4 together.

**NTC R<sub>25°C</sub>:** 10 kΩ ± 1 %, B<sub>25/85</sub> = 3435

**Voltage:** 0 to 50 mVdc. Impedance >> 1 MΩ

Sensor Type	Maximum Measurement Range	Minimum Measurement Range
Voltage	0 to 50 mV	5 mV
Thermocouple K	-150 to 1370 °C	100 °C
Thermocouple J	-100 to 760 °C	100 °C
Thermocouple R	-50 to 1760 °C	400 °C
Thermocouple S	-50 to 1760 °C	400 °C
Thermocouple T	-160 to 400 °C	100 °C
Thermocouple N	-270 to 1300 °C	100 °C
Thermocouple E	-90 to 720 °C	100 °C
Thermocouple B	500 to 1820 °C	400 °C
Pt100	-200 to 650 °C	40 °C
Pt1000	-200 to 650 °C	40 °C
NTC	-30 to 120 °C	40 °C

Table 1 – Sensors accepted by the transmitter

**Switch-on delay:** < 2.5 s. The accuracy is only guaranteed after 15 min.

**Terms of reference:** ambient: 25 ° C; voltage: 24 Vdc, load: 250 Ω; settling time: 10 minutes.

**Temperature Effect:** < ±0.16 % / 25 °C

**Response time:** typical 1.6 s.

**Maximum voltage allowed at input terminals no sensor:** 3 V.

**RTD current:** 800 μA.

**RTD cable resistance effect:** 0.005 °C / Ω

**Maximum allowable cable resistance for RTD:** 25 Ω.

Sensor Type	Typical Accuracy	Minimum Accuracy
Pt100 / Pt1000 (-150 to 400 °C)	0,10 %	0,12 %
Pt100 / Pt1000 (-200 to 650 °C)	0,13 %	0,19 %
mV, K, J, T, E, N, R, S, B	0.1 % (*)	0.15 % (*)
NTC	0.3 °C	0.7 °C

Table 2 – Calibration error, percentage of the full measurement range

(\*) Add cold junction compensation: < ± 1 °C.

**Power supply influence:** 0.006 % / V typical (percentage of the full measure range).

**Output:** 4-20 mA or 20-4 mA current, 2-wired; linear in relation to the temperature measurement by the selected sensor.

**Output Resolution:** 2 μA.

**Power supply:** 10 to 35 Vdc, across the transmitter;

**Maximum load (RL):** RL (max.) = (Vdc – 10) / 0.02 [Ω]

Where: Vdc= Power supply voltage (10-35 Vdc)

**Operating Temperature:** -40 to 85 °C

**Humidity:** 0 to 90 % RH

**Electromagnetic Compatibility:** EN 61326-1:2006

**No electrical isolation between input and output.**

**Internal protection against polarity inversion.**

**Cold junction compensation for thermocouples.**

**Dimensions:** 43.5 mm (diameter) x 20.5 mm (height)

**Connection Wire Cross Section:** 0.14 a 1.5 mm<sup>2</sup>

**Screw Tightening:** 0.8 Nm.

**Housing:** ABS UL94-HB.

## CONFIGURATION

When the transmitter is used with the factory setting, no further action is required and the transmitter is ready to be installed. Changes to the configuration are possible through the TxConfig II software, provided free of charge.

The TxBlock-USB Setup Kit consisting of the Txconfig II software and USB cable can be purchased from the manufacturer or any authorized distributor. The Txconfig II software is continuously updated and new versions can be downloaded at no charge from the manufacturer's website. To install, execute the *TxConfigIISetup.exe* file and follow the instructions.

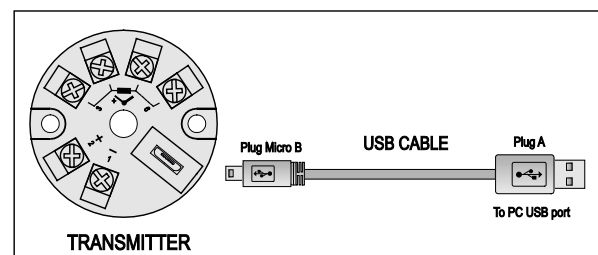

Fig. 1 – USB cable connection

During the setup, the transmitter is powered by the USB, not requiring an external power supply.

The transmitter setup can also be made by connecting it to the loop, using the *loop* power supply. There is no electrical insulation between the transmitter and the communication port (interface), therefore it is not recommended to configure it with the sensor inlet connected to the process. See Fig. 2.

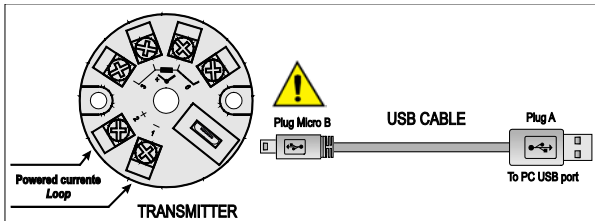
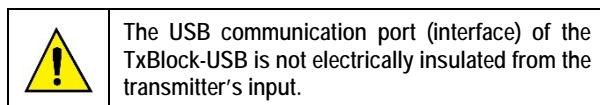

Fig. 2 – USB cable connections – Loop powered

After these connections, the user must run the *TxConfig II* software and, if necessary, consult the *Help* topic to help using the software.



### SOFTWARE CONFIGURATION:

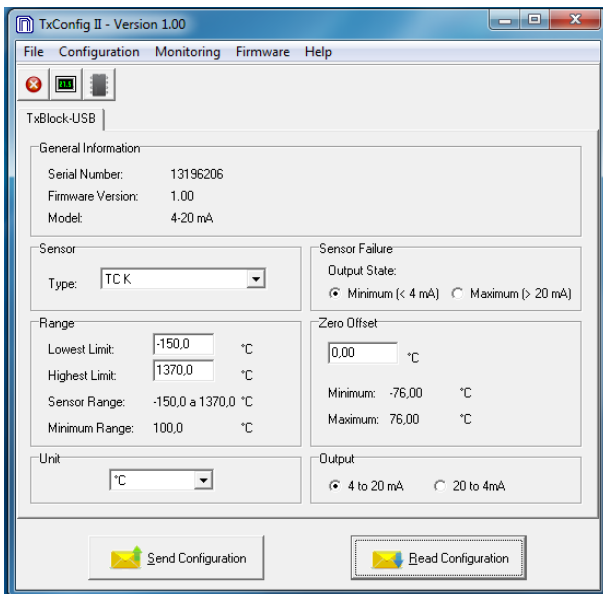

Fig. 3 – *TxConfig II* software main screen

The fields in the screen mean:

- General Information:** This field shows information that identifying the transmitter. This information should be sent to the manufacturer in an eventual request for technical assistance.
- Sensor:** Select the type of sensor to be used. See Table 1.
- Measuring Range:** Sets de measurement range of the transmitter.

**Lower Range Limit:** equivalent temperature for a current of 4 mA.

**Upper Range Limit:** equivalent temperature for a current of 20 mA.

#### Sensor Range

The values chosen cannot exceed the **range of sensor** shown in this field. See Table 1 of this manual.

#### Minimum Range

Do not set a lower band (span) that the **Minimum Range** indicated below in this same field. See Table 1 of this manual.

- Sensor Failure:** It establishes the output behavior, when the transmitter indicates a failure:

**Minimum:** output current goes to < 3.6 mA (down-scale), typically used for refrigeration.

**Maximum:** output current goes to > 22.0 mA (up-scale), typically used for heating.

- Zero Correction:** It corrects small deviations presented in the transmitter output, for example, when the sensor is replaced.
- Send Configuration:** It applies the new setup. Once sent, the setup will be immediately adopted by the transmitter.
- Read Configuration:** Reads the current setup in the transmitter connected. The screen now presents the current setup that may be changed by the user.

### FACTORY SETTING:

- Sensor: Pt100 3-wire, range 0 to 100 °C
- Sensor failure: upscale (maximum).
- 0 °C zero correction.
- Unit: °C;
- Output: 4-20 mA.

Upon purchase order, the user can define a specific setup.

### MECHANICAL INSTALLATION

The TxBlock-USB transmitter is suitable to be installed in heads. Vibrations, moisture and extreme temperatures, electro-magnetic interference, high voltage and other interferences can permanently damage the unit, and could cause error in the measured value.

### DIMENSIONS:

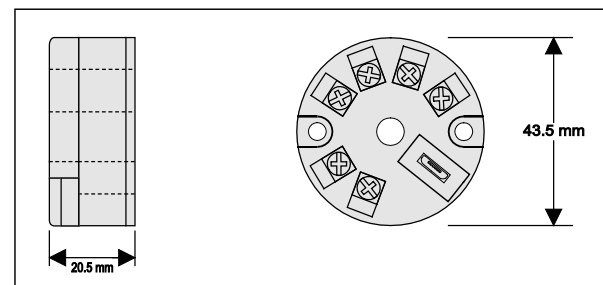

Fig. 4 – Transmitter dimensions

### ELECTRICAL INSTALLATION

- Section of the cable used: 0.14 to 1.5 mm<sup>2</sup>
- Recommended torque in the terminal: 0.8 Nm.

### RECOMMENDATIONS FOR INSTALLATION

- Sensor signals conductors must go through the plant system separate from power leads (loop), if possible in grounded conduits.
- The instruments must be powered from the instrumentation power supply circuit.
- In control and monitoring applications is essential to consider what can happen when any part of the system fails.
- It is recommended the use of suppressors in contact coils, solenoids and any inductive load.

## ELECTRICAL CONNECTIONS

The figures below show the electrical connections required. The terminals 3, 4, 5 and 6 are dedicated to the sensor connection. **LOAD** represents the 4-20 mA current measuring device (indicator, controller, recorder, etc.).

### PT100 2-WIRE

**Note:** When the Pt100 2-wire the terminals 3 and 4 must be interconnected, according to the figure below.

The Pt100 wire length **should be less than 30 cm** to maintain the measurement error within specifications (electrical resistance).

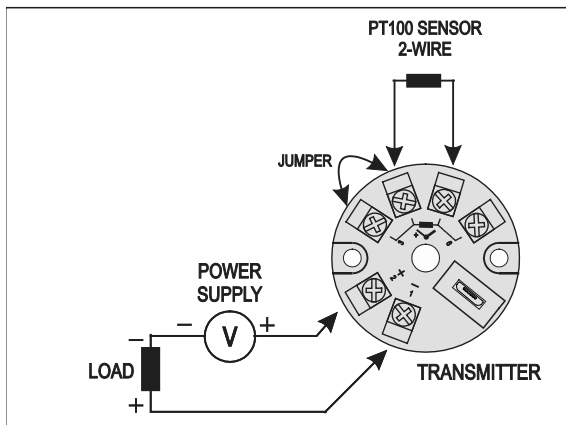

Fig. 5 – Transmitter electrical connections (Pt100 2-wire)

### PT100 3-WIRE

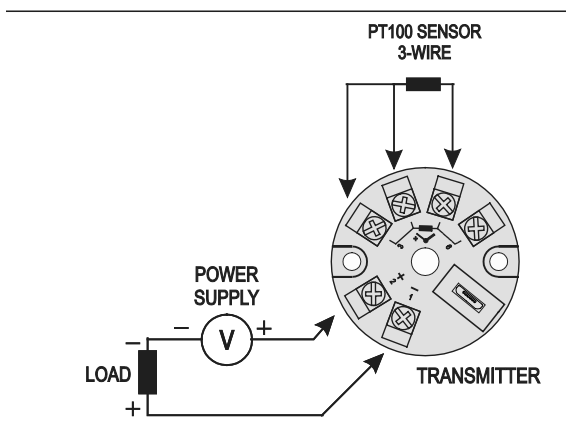

Fig. 6 – Transmitter electrical connections (Pt100 3-wire)

### PT100 4-WIRE

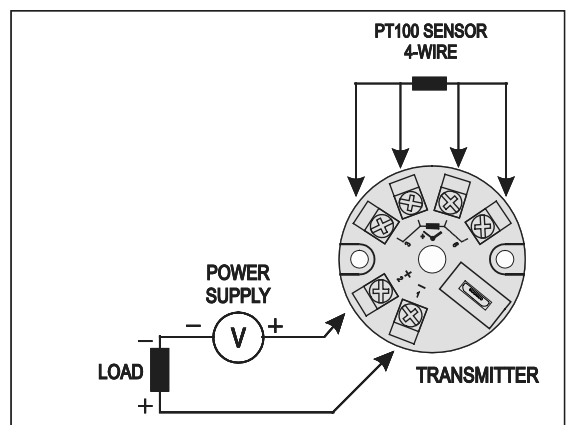

Fig. 7 – Transmitter electrical connections (Pt100 4-wire)

**Pt1000 3-wire / Pt100 3-wire and 4-wire:** For appropriate cable resistance compensation they should be equal for all legs. Maximum wire resistance is  $25 \Omega$  per wire leg. Usage of a 3 or 4 wire with conductors of equal length and gauge is recommended.

### NTC 2-WIRE

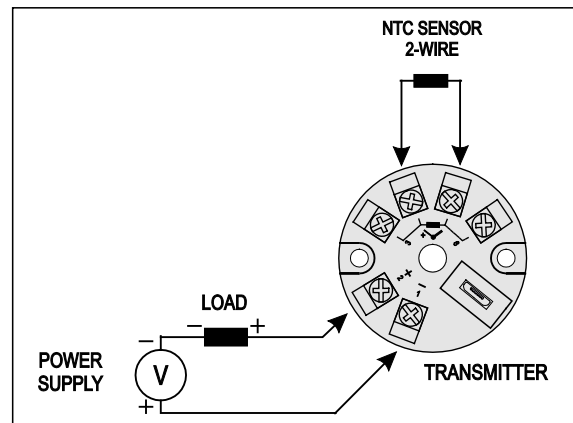

Fig. 8 – Transmitter electrical connections (NTC 2-wire)

### THERMOCOUPLES

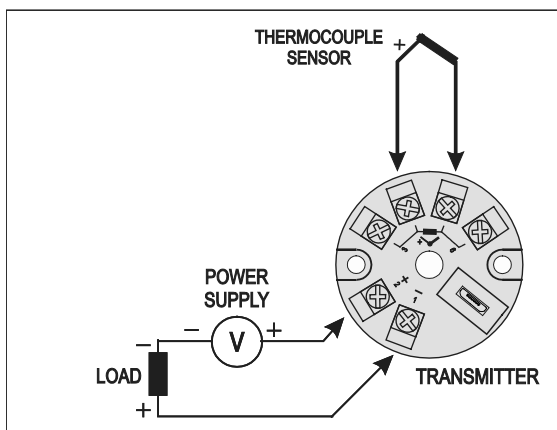

Fig. 9 – Transmitter electrical connections (Thermocouple)

### VOLTAGE (0-50 mV)

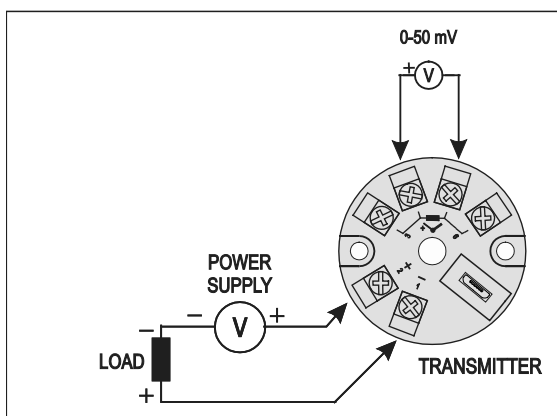

Fig. 10 – Transmitter electrical connections (0-50 mV)

## OPERATION

The sensor offset can be changed through the *TxConfig II* software. The USB cable may be connected to the transmitter without causing any measurement errors. See item *Zero Correction* in the chapter **CONFIGURATION** of this manual.

The user must choose the most suitable sensor and range to the process. The chosen range must not exceed the maximum range of measurement defined for the sensor and should not be smaller than the minimum range for the same sensor.

It is important to note that the transmitter accuracy is based on the maximum range of the sensor used, even when a narrower range is programmed.

### Example:

- The Pt100 sensor in the range 0 to 100 °C and accuracy of 0.12 %, the maximum error will be 1.02 °C (0.12 % of 850 °C).
- The Pt100 sensor in the range 500 to 600 °C and accuracy of 0.19 %, the maximum error will be 1.61 °C (0.19 % of the 850 °C).

**Note:** When measurements are made at the transmitter, see if the Pt100 excitation current required by the calibrator is compatible with the Pt100 excitation current used in the transmitter: 0.8 mA.

## SAFETY INFORMATION

Any control system design should take into account that any part of the system has the potential to fail. This product is not a protection or safety device and its alarms are not intended to protect against product failures. Independent safety devices should be always provided if personnel or property are at risk.

Product performance and specifications may be affected by its environment and installation. It's user's responsibility to assure proper grounding, shielding, cable routing and electrical noise filtering, in accordance with local regulations, EMC standards and good installation practices.

## SUPPORT AND MAINTENANCE

This product contains no serviceable parts inside. Contact our local distributor in case you need authorized service. For troubleshooting, visit our FAQ at [www.novusautomation.com](http://www.novusautomation.com).

## LIMITED WARRANTY AND LIMITATION OF LIABILITY

NOVUS warrants to the original purchaser that this product is free from defects in material and workmanship under normal use and service within one (1) year from the date of shipment from factory or from its official sales channel to the original purchaser.

NOVUS liability under this warranty shall not in any case exceed the cost of correcting defects in the product or of supplying replacement product as herein provided and upon the expiration of the warranty period all such liability shall terminate.

For complete information on warranty and liability limitations, check appropriate section in our web site: [www.novusautomation.com/warranty](http://www.novusautomation.com/warranty).