

---

## Solid State SSR

### Monophasic 150, 200 and 300 A

INSTRUCTION MANUAL V1.0x A



Product marketed by NOVUS Automation.

## 1. PRESENTATION

The **SSR Static Switch** is an electronic device used to drive resistive and inductive loads with numerous advantages over conventional electromechanical (contactor) relays. A control signal determines the activation of the load connected to the power terminals of the device.

Differentials of this product:

- No electrical noise, sparking or mechanical wear;
- Status indicator light (LED) on or off;
- Internal protection circuit (Snubber) for the output;
- Zero Crossing: turns on at zero Volt and turns off at zero Ampère;
- Optical isolation between command and power.

## 2. IDENTIFICATION

Attached to the device is the identification tag. Check if the features described on this tag are in accordance with what was requested.

## 3. OPERATION

After receiving a command signal at its input terminals, the static switch conducts (turns on) and feeds the load. The conduction happens effectively at the next zero crossing of the mains voltage. The same happens in the shutdown. The command signal is removed, but the key only effectively blocks (turns off) the next zero crossing of the electric current on the load.

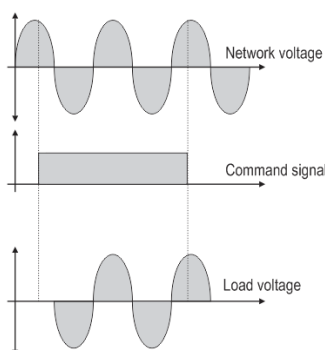

Fig. 01 – Electrical voltage on a resistive load

This implies delays never exceeding 8.3 milliseconds between the tripping time of the ON/OFF command and the effective charging/discharging of the load.

Turning the load on and off at zero crossing always brings important advantages to the installation. Practically no electrical interference is generated at the installation and the switch is not subjected to severe switching conditions.

It is impossible to switch DC voltage, only alternating voltage (AC).

## 4. INSTALLATION

To install the device, the following recommendations must be observed:

- Fix it upright, with the fan blowing up.
- There should be a free area below and above the device, with a distance of 15 cm from other devices or wall, to allow good air circulation.
- Protection and disconnection devices must be provided.
- As a safety measure for installations, the maximum load current must not exceed 80% of the rated current of the SSR module.
- At these nominal current values, well-secured terminals, suitable conductors and environments with adequate ventilation help in the installation efficiency.
- The recommended cables are 70, 95 and 185 mm<sup>2</sup> for the 150, 200 and 300 A chains, respectively.

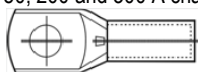

- To the connections, use compatible compression terminals:



**Under rated current, the ambient temperature must not exceed 40 °C.**

## 5. ELECTRICAL CONNECTIONS

When installing the SSR module, **Command Signal**, **Fan** and **Load** connections are required.

- The control signal must be connected to terminals 1 and 2 of the side connector. A thermal protection relay is already inserted in this circuit. It interrupts the control circuit when the temperature of the heatsink exceeds 80 °C.
- In the connection with the load, the power buses (or cables) are connected directly to the key buses of the switch. An ultrafast fuse must be used to protect the installation.

- Fan is available on the side connector terminals 3, 4, 5, and 6. The installer must observe the supply voltage of the fan and connect it according to the respective figures.

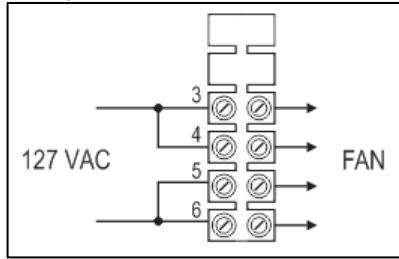

Fig. 02 – Fan connection at 127 Vac

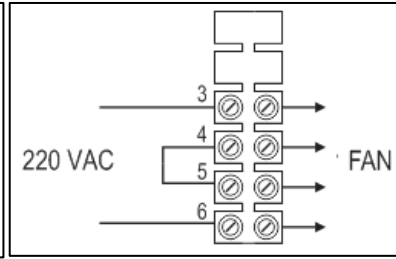

Fig. 03 – Fan connection at 220 Vac

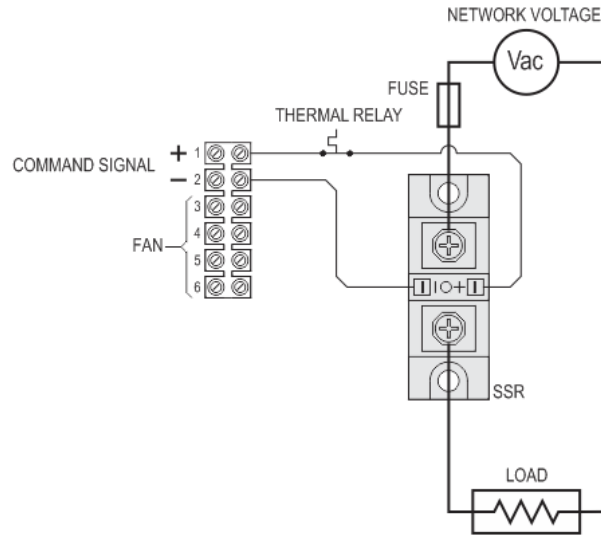

Fig. 04 – Electrical Connections - Command Signal and SSR Static Key Charge

## 6. DISSIPATION OF HEAT

With the current of load circulating, there is generation of intense heat on the SSR. This heat should be quickly transferred (dissipated) into the environment to prevent the overheating of the SSR. The nominal load current ( $I_L$ ) values defined for each SSR model take into account the use of a suitably calculated heatsink.

The SSR static switch already incorporates the heatsink in the dimension suitable for the rated current specified and also the fan required.

As a safety measure for installations, the nominal load current shall not exceed 80% of the rated current of the switch.

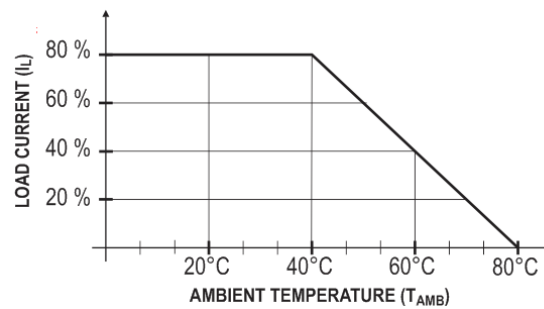

Fig. 05 – Ambient Temperature and Charging Current

## 7. OVERHEATING PROTECTION

The SSR static switch has a NF (normally closed) thermal relay that is in series with the control terminals. This thermal relay interrupts the command signal by turning off the SSR when the heatsink temperature exceeds 80 °C. This prevents damage to the electronic relays of the switch.

## 8. DIMENSION

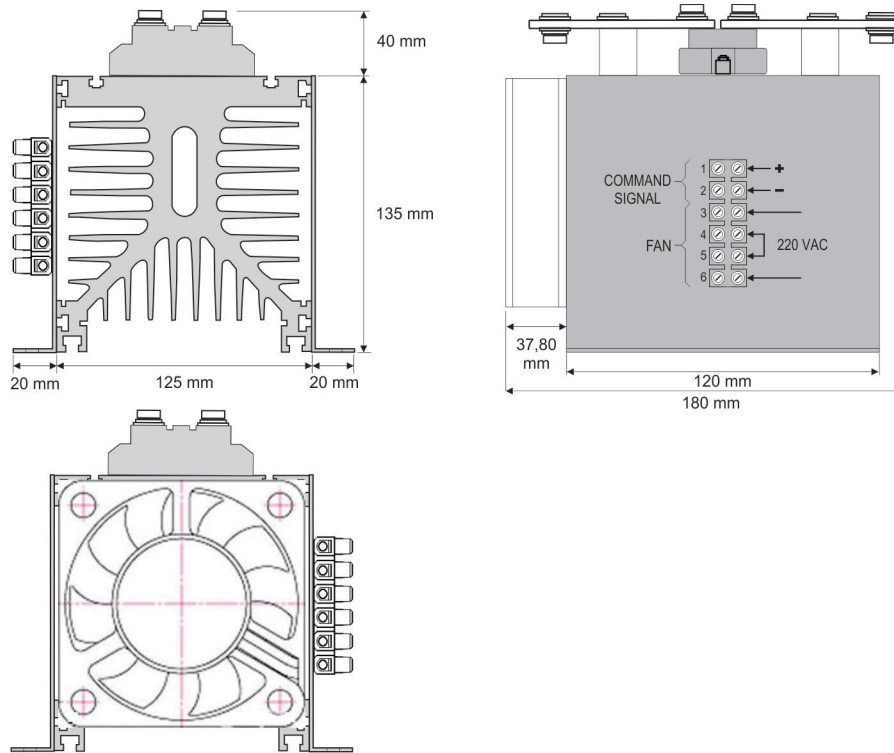

Fig. 06 – Heatsink NDP3 dimensions

## 9. PROBLEMS SOLUTIONS

### 9.1 STATIC SWITCH DOES NOT TURN ON

The following possibilities must be observed:

- Inverted control signal;
- Control signal without sufficient voltage (minimum);
- Minimum load current not reached;
- Minimum load voltage not reached;
- Overheated device;
- Protection relay is defective, causing overheating.

### 9.2 STATIC SWITCH TURNS OFF IMPROPERLY

The following possibilities must be observed:

- Overheating caused by overload current;
- Overheating caused by a defective fan;
- Overheating caused by excessively hot environment;
- Overheating caused by poorly made load connections or badly tightened screws.

The user must identify the cause of the defect and arrange the correction, always with the key turned off.

## 10. TECHNICAL SPECIFICATIONS

Operation Conditions	Unit	Model		
		Static Switch 4880	Static Switch 48100	Static Switch 48300
Load Current (I <sub>L</sub> )	A rms	150	200	300
Load Voltage	V rms	40 to 480		
Voltage Drop (V <sub>SSr</sub> )	V rms	1.6 to 1.8		
Leakage Current	mA rms	< 5.0		
Frequency	Hz	47 to 63		
dv/dt	V/μs	300		
Control Voltage	Vcc	3 to 32		

<b>Control Current</b>	mAcc	6 to 20
<b>Switch Time</b>	ms	< 10
<b>Shoot</b>		Zero cross
<b>Isolation</b>	V rms	2000
<b>Housing Temperature</b>	°C	-40 to 80
<b>Ambient Temperature</b>	°C	-20 to 40
<b>Protection Actuation Temperature</b>	°C	80

**Table 01** – Technical Specifications

## 11. WARRANTY

The warranty conditions are set forth on our website [www.novusautomation.com/warranty](http://www.novusautomation.com/warranty).