

**INTRODUCTION**

The **N1100** series of Universal Process Controllers is a real breakthrough in versatility for holding in one single instrument all the major features that are needed for the vast majority of industrial processes.

The sophisticated and consistent software and its advanced truly universal SMT circuitry make the **N1100** the only 1/16 DIN PID instrument in the world to accept configuration of both input signal and control output through the front keyboard without any hardware change.

From the very simple applications as a temperature controller to the most complex systems of distributed control with PLC's or SCADA networks, the **N1100** is the right answer to your needs for industrial, building or laboratory automation.



**FEATURES**

- Universal multi-sensor input without the need for hardware change or recalibration.
- Outputs: 2 SPST relays, 1 SPDT relay (optional), linear 4-20 mA and up to 3 logic pulse outputs (2 optional).
- The outputs can be configured as control, alarm and analog retransmission (4-20 mA).
- Up to 2 timer relay alarms, settable from 0 to 6500 s, ideal for servo-positioning with up/down function.
- Alarm functions: low, high, differential, low differential, high differential, sensor break, ramp and soak event, and inoperable.
- PV or Setpoint 0-20 mA analog retransmission.
- Auto/Manual "bumpless" transfer.
- Up to 3 digital inputs with 5 programmable functions.
- Sensor break protection in any condition.
- 4 to 20 mA Remote Setpoint input.
- Programmable Soft Start (0 to 9999 seconds).
- Ramp and Soak: Seven 7-segment profiles, can be linked to make longer programs of up to 49 segments.
- RS-485 digital Communication, MODBUS RTU protocol, 19200 baud rate.
- Heater break protection (option).
- Up to 247 slave controllers in a network.
- Auto tuning PID.
- Consistent menu adapts to the installed options.
- Unique electronic 8-digit serial number can be viewed at the display.
- Silicone rubber keypad.
- Front panel: IP65, Polycarbonate UL94 V-2.
- Back panel: IP30, ABS+PC UL94 V-0.
- Keypad protection prevents unauthorized parameters changes.
- Circuitry can be removed from the front panel.
- Terminal connection: 18 screws accepting 6.3 mm fork lugs.

**SPECIFICATIONS**

- Accepts J, K, T, N, R, S thermocouples; Pt100, 4-20 mA, 0-50 mVdc, 0-5 Vdc.
- Internal resolution: 19500 levels.
- Measuring resolution: 12000 levels.
- Dual LED display: red 10 mm height PV upper display, green 8 mm height SV display.
- Sampling rate: 5 per second.
- Control output update: 200 ms.
- Isolated 4-20 mA output with 1500 level high resolution, 550 Ohms maximum load.
- 2 SPST relays and 1 SPDT relay (optional) 3A @250 Vac.
- Power supply: 85 to 250 Vac, 50/60 Hz; optionally 24 Vdc/ac.
- Maximum consumption: 3 VA.
- Ambient conditions: 0 to 55°C, 20 to 95% RH
- Dimensions: 48 x 48 x 110 mm.
- Panel cutout: 45,5 x 45,5 mm.
- Weight: 150 g.

**ELECTRICAL CONNECTIONS**

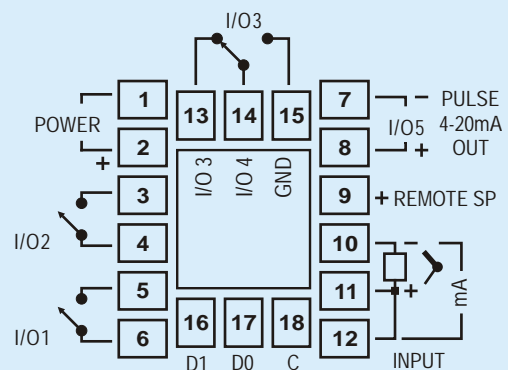

**HOW TO SPECIFY**

The basic unit includes universal input, 2 SPST relays and one 4-20 mA output that can be configured as logic pulse output or digital input.  
**Option 1:** SPDT relay (for control or alarm output). **Option 2:** 2 Digital I/Os. **Option 3:** Heater break detection. **Option 4:** RS-485 digital communication.  
**Note:** Options 1, 2 e 3 are excludent.  
**Accessory 1:** Current transformer for heater break protection.  
 A factory manufacturing Calibration Certificate can be issued under request.