

# Matrix<sup>®</sup> AP

400V – 690V

## TECHNICAL REFERENCE MANUAL

FORM: MAP-TRM-E  
REL. September 2015  
REV. 019  
© 2015 MTE Corporation

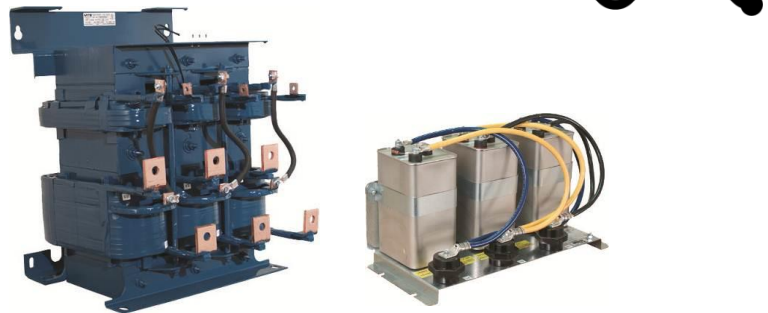

**WARNING**

High Voltage! Only a qualified electrician can carry out the electrical installation of this filter.

### Quick Reference

<b>1</b>	Selection Guide	Pages 7 – 35
<b>2</b>	Installation Guide	Pages 36 – 51
<b>3</b>	Startup/Troubleshooting	Pages 52 – 56
<b>4</b>	Reference Drawings	Pages 57 – 77

## TABLE OF CONTENT

<b>1. WARNINGS .....</b>	<b>4</b>
WARNINGS AND CAUTIONS.....	4
GENERAL SAFETY INSTRUCTIONS.....	5
<b>2. INTRODUCTION.....</b>	<b>6</b>
RECEIPT & REPAIR STATEMENT .....	6
<b>3. HOW TO SELECT .....</b>	<b>7</b>
SELECTION GUIDE .....	7
PART NUMBER CONFIGURATION.....	8
MATRIX AP 400 VOLTS, 50HZ.....	9
<i>Part Number Selection Tables .....</i>	<i>9</i>
FILTER EFFICIENCY + WATT LOSS .....	11
<i>Matrix AP 400V, 50Hz .....</i>	<i>11</i>
<i>Mounting Patterns .....</i>	<i>12</i>
<i>Capacitor and Cap-panel Bolt Hole Mounting Patterns .....</i>	<i>13</i>
MATRIX AP 480 VOLTS, 60HZ.....	14
<i>Part Number Selection Tables .....</i>	<i>14</i>
MATRIX AP 480 VOLTS, 60HZ.....	15
<i>Part Number Selection Tables .....</i>	<i>15</i>
FILTER EFFICIENCY + WATT LOSS .....	17
<i>Matrix AP 480V, 60Hz .....</i>	<i>17</i>
<i>Mounting Patterns .....</i>	<i>18</i>
<i>Capacitor and Cap-panel Bolt Hole Mounting Patterns .....</i>	<i>19</i>
<i>Capacitor and Cap-panel Bolt Hole Mounting Patterns .....</i>	<i>20</i>
MATRIX AP 600 VOLTS, 60HZ.....	21
<i>Part Number Selection Tables .....</i>	<i>21</i>
<i>Filter Efficiency + Watt loss .....</i>	<i>23</i>
<i>Mounting Patterns .....</i>	<i>24</i>
<i>Capacitor and Cap-panel Bolt Hole Mounting Patterns .....</i>	<i>25</i>
MATRIX AP 690 VOLTS, 50HZ.....	26
<i>Part Number Selection Tables .....</i>	<i>26</i>
<i>Filter Efficiency + Watt loss .....</i>	<i>27</i>
<i>Mounting Patterns .....</i>	<i>28</i>
<i>Capacitor and Cap-panel Bolt Hole Mounting Patterns .....</i>	<i>29</i>
<b>4. PRODUCT SPECIFICATIONS .....</b>	<b>30</b>
PERFORMANCE SPECIFICATIONS .....	30
ENCLOSURES .....	31
AGENCY APPROVALS .....	31
WARRANTY.....	31
OVER TEMPERATURE SWITCH.....	31
<b>5. TYPICAL PERFORMANCE DATA .....</b>	<b>32</b>
TYPICAL HARMONIC SPECTRUM .....	32
POWER FACTOR .....	33
PERFORMANCE WITH UNBALANCED LINE VOLTAGE (TYPICAL) .....	33
ALTITUDE DERATING.....	34
TEMPERATURE DERATING.....	34
VOLTAGE DISTORTION DERATING CURVE .....	35
<b>6. HOW TO INSTALL .....</b>	<b>36</b>
INSTALLATION CHECKLIST .....	36
MECHANICAL MOUNTING.....	38
POWER WIRING CONNECTION .....	38

BASIC SCHEMATIC DIAGRAM .....	40
OPEN PANEL UNIT INTERCONNECTION DIAGRAM .....	41
ENCLOSED UNIT INTERCONNECTION DIAGRAM.....	42
CONTACTOR OPTIONS .....	43
CONTACTOR COIL SWITCHING CURRENTS .....	48
TORQUE RATINGS.....	49
TORQUE RATINGS.....	51
<b>7. START UP .....</b>	<b>52</b>
STARTUP CHECKLIST .....	52
<b>8. TROUBLESHOOTING.....</b>	<b>54</b>
MATRIX AP HARMONIC FILTER FIELD CHECKS .....	55
<b>APPENDIX.....</b>	<b>57</b>
AP HMR MOUNTING & TERMINAL LOCATIONS .....	58
AP HMR 6 – 44 Amp (400V & 480V) .....	58
AP HMR 6 – 34 Amp (600V) .....	58
AP HMR 52 – 66 Amp (690V) .....	59
AP HMR 52 - 103 Amp (400V & 480V) .....	60
AP HMR 44 – 83 Amp (600V) .....	60
AP HMR 83 - 103 Amp (690V).....	61
AP HMR 128 - 320 Amp (400V & 480V) .....	62
AP HMR 103 – 208 Amp (600V) .....	62
AP HMR 128 – 165 Amp (690V) .....	62
AP HMR 208 – 240 Amp (690V) .....	63
AP HMR 403 - 482 Amp (400V & 480V) .....	64
AP HMR 240 – 403 Amp (600V) .....	65
AP HMR 320 – 482 Amp (690V) .....	66
AP HMR 482 – 786 Amp (600V) .....	67
AP HMR 636 Amp (690V) .....	67
AP HMR 636 - 1200 Amp (400V & 480V) .....	68
AP HMR 1600 - 2300 Amp (480V).....	69
CAP-ASSEMBLY MOUNTING & TERMINAL LOCATIONS .....	70
ENCLOSED UNIT EXTERNAL DETAILS .....	72
CAB-12AP .....	72
CAB-17AP .....	73
CAB-26AP .....	74
CAB-26APD.....	75
CAB-42AP .....	76
CAB-48AP .....	77

## List of Figures

Figure 5-1: Load Effect on THID .....	32
Figure 5-2: Typical Harmonic Spectrum with and without Matrix AP .....	32
Figure 5-3: Altitude Derating Curve .....	34
Figure 5-4: Temperature Derating .....	34
Figure 5-5: Voltage Distortion Derating Curve .....	35
Figure 6-1: Basic Schematic Diagram .....	40
Figure 6-2: Open Panel Interconnection .....	41
Figure 6-3: Enclosed Interconnection .....	42
Figure 6-4: Contactor Options – 002.....	43
Figure 6-5: Contactor Option – 009 .....	44
Figure 6-6: Contact Option – 012.....	45
Figure 6-7: Contact Option - 013 .....	46

## List of Tables



Table 3-1: Matrix AP 400V Open Panel.....	9
Table 3-2: Matrix AP 400V Enclosed .....	10
Table 3-3: Watt Loss - Matrix AP 400V, 50Hz .....	11
Table 3-4: Matrix AP 400V HMR Bolt Hole Mounting Patterns.....	12
Table 3-5: Matrix AP 400V Capacitor and Cap-panel Bolt Hole Mounting Patterns.....	13
Table 3-6: Matrix AP 480V Open Panel.....	14
Table 3-7: Matrix AP 480V Enclosed .....	16
Table 3-8: Watt Loss - Matrix AP 480V, 60Hz .....	17
Table 3-9: Matrix AP 480V Mounting Patterns.....	18
Table 3-10: Matrix AP 480V Capacitor and Cap-panel Bolt Hole Mounting Patterns .....	19
Table 3-11: Matrix AP 600V Open Panel.....	21
Table 3-12: Matrix AP 600V Enclosed .....	22
Table 3-13: Watt Loss - Matrix AP 600V, 60Hz .....	23
Table 3-14: Matrix AP 600V Mounting Patterns.....	24
Table 3-15: Matrix AP 600V Capacitor and Cap-panel Bolt Hole Mounting Patterns .....	25
Table 3-16: Matrix AP 690V Open Panel.....	26
Table 3-17: Watt Loss - Matrix AP 690V, 50Hz .....	27
Table 3-18: Matrix AP 690V Mounting Patterns.....	28
Table 3-19: Matrix AP 690V Capacitor and Cap-panel Bolt Hole Mounting Patterns .....	29
Table 4-1: Performance Specifications .....	30
Table 4-2: Over Temperature Switch.....	31
Table 5-1: Performance with Unbalanced Line Voltage (Typical).....	33
Table 6-1: Contactor Coil Switching Currents.....	48
Table 6-2: Torque Ratings-400V, 480V, 600V.....	49
Table 6-3: Torque Ratings-690V.....	51
Table 8-1: Troubleshooting Guide .....	56

# 1. WARNINGS

## Warnings and Cautions



There are two types of warnings in this manual:

- WARNING describes situations that can lead to serious faults, physical injuries, or even death.
- Caution describes situations that can lead to malfunction or possible equipment damage.











 <b>WARNING</b>	WARNING describes situations that can lead to serious faults, physical injuries, or even death.
 <b>Caution</b>	Caution describes situations that can lead to malfunction or possible equipment damage.

The following symbols are used in this manual.

- High Voltage Warning: warns of situations that dangerously high voltage is involved. Failure to use proper precautions may lead to serious injury or even death.
- General Warning: warns of situations that can result in serious injury or death if proper precautions are not used.
- General Caution: identifies situations that could lead to malfunction or possible equipment damage.

 <b>WARNING</b>	High Voltage Warning: warns of situations that dangerously high voltage is involved. Failure to use proper precautions may lead to serious injury or even death.
 <b>WARNING</b>	General Warning: warns of situations that can result in serious injury or death if proper precautions are not used.
 <b>Caution</b>	General Caution: identifies situations that could lead to malfunction or possible equipment damage.

## General Safety Instructions

 <b>WARNING</b>	<b>High Voltage! Only a qualified electrician can carry out the electrical installation of this filter.</b>
 <b>WARNING</b>	High voltage is used in the operation of this filter. Use extreme caution to avoid contact with high voltage when operating, installing or repairing this filter. <b>Injury or death may result if safety precautions are not observed.</b>
 <b>WARNING</b>	The opening of the branch circuit protective device may be an indication that a fault current has been interrupted. To reduce the risk of fire or electrical shock, current-carrying parts and other components of the filter should be examined and replaced if damaged.
 <b>WARNING</b>	An upstream disconnect/protection device must be used as required by the National Electrical Code (NEC) or governing authority.
 <b>WARNING</b>	Even if the upstream disconnect/protection device is open, the drive down stream of the filter may feed back high voltage to the filter. The drive safety instructions must be followed. <b>Injury or death may result if safety precautions are not observed.</b>
 <b>WARNING</b>	The filter must be grounded with a grounding conductor connected to all grounding terminals. Open panel filters must have reactor grounded through a 2"x2" area cleaned of paint and varnish on lower mounting bracket.
 <b>WARNING</b>	Only spare parts obtained from MTE Corporation or an authorized MTE distributor can be used.
 <b>WARNING</b>	After removing power, allow at least five minutes to elapse and verify that the capacitors have discharged to a safe level before contacting internal components. Connect a DC voltmeter across the capacitor terminals and ensure that the voltage is at a safe level.
 <b>Caution</b>	Loose or improperly secured connections may damage or degrade filter performance. Visually inspect and secure all electrical connections before power is applied to the filter.
 <b>Caution</b>	The user of this filter must assure that the input voltage and frequency is correct for the filter rating and that the voltage applied falls within the rated operating tolerance envelop specified for the filter. For sever power line applications where the power feed is likely to experience surges and transients that exceed the input voltage rating, it is recommended that a TVSS (Transient Voltage Surge Suppression) or SPD (Surge Protection Device) be deployed ahead of the filter to reduce the possibility of exceeding the filter rated voltage. Consult with TVSS or SPD manufacturer to determine the correct protection requirements for your power line conditions.

## 2. INTRODUCTION

The purpose of the manual is to properly specify, size, and install the Matrix AP.

For most current information, please refer to website  
<http://www.mtecorp.com/products/matrix-ap-harmonic-filters/>

### Receipt & Repair Statement

#### Upon Receipt of this Filter:

The Matrix AP Harmonic Filter has been subjected to demanding factory tests before shipment. Carefully inspect the shipping container for damage that may have occurred in transit. Then unpack the filter and carefully inspect for any signs of damage. Save the shipping container for future transport of the filter.

**In the event of damage, please contact and file a claim with the freight carrier involved immediately.**

If the equipment is not going to be put into service upon receipt, cover and store the filter in a clean, dry location. After storage, ensure that the equipment is dry and that no condensation or dirt has accumulated on the internal components of the filter before applying power.

#### Repair/Exchange Procedure

MTE Corporation requires a Return Material Authorization Number and form before we can accept any filters that qualify for return or repair. If problems or questions arise during installation, setup, or operation of the filter, please contact MTE for assistance at:

Toll Free: 1-800-455-4MTE (1-800-455-4683)

International Tel: 262-253-8200

Fax: 262-253-8222

## 3. HOW TO SELECT

### Selection Guide

The MTE Corporation Matrix AP Harmonic Filter is designed for harmonic mitigation of 6-pulse inverter drives supplying variable torque loads in a wide variety of applications. The suitability of this filter for a specific application must therefore be determined by the customer. In no event will MTE Corporation assume responsibility or liability for any direct or consequential damages resulting from the use or application of this filter, nor will MTE Corporation assume patent liability with respect to the use of information, circuits or equipment described in this instruction manual. The Matrix AP Harmonic Filter uses a patent pending Adaptive Passive Harmonic Mitigating Reactor (AP HMR) technology to limit full load current distortion to less than 5% THID and 8% at 30% load.

Matrix AP Harmonic Filters are available in Open Panel, NEMA 1/2, and 3R mechanical configurations.

For inverters feeding isolation transformers select a filter with a current rating equal to or greater than that of the transformer primary current.

#### Please verify information below for proper selection:

- Line Voltage and Frequency:** Input voltage from 400V – 690V at standard frequency. See Table 4-1 (p30) for specification.
- Current Rating:** 400V 6-1200 Amp, 480V 6-2300 Amp, 600V 6-786 Amp, 690V 52-636 Amp.
- Voltage Distortion:** See Figure 5-5 (p35) for voltage distortion derating curve.
- Contactors Option:** See Figure 6-4 (p43) for contactor option 002, Figure 6-5 (p44) for contactor option 009, Figure 6-6 (p45) for contactor option 012, Figure 6-7 (p46) for contactor option 013.
- Temperature:** See Table 4-1: Performance Specifications (p30) for specification, and Figure 5-4 (p34) for temperature derating.
- Altitude:** 3,300 feet above sea level without derating. See Figure 5-3 (p34) for derating curve.
- Enclosure Type:** Open Panel, NEMA 1/2 & NEMA 3R, see Enclosures (p31) for enclosure descriptions.



## Part Number Configuration

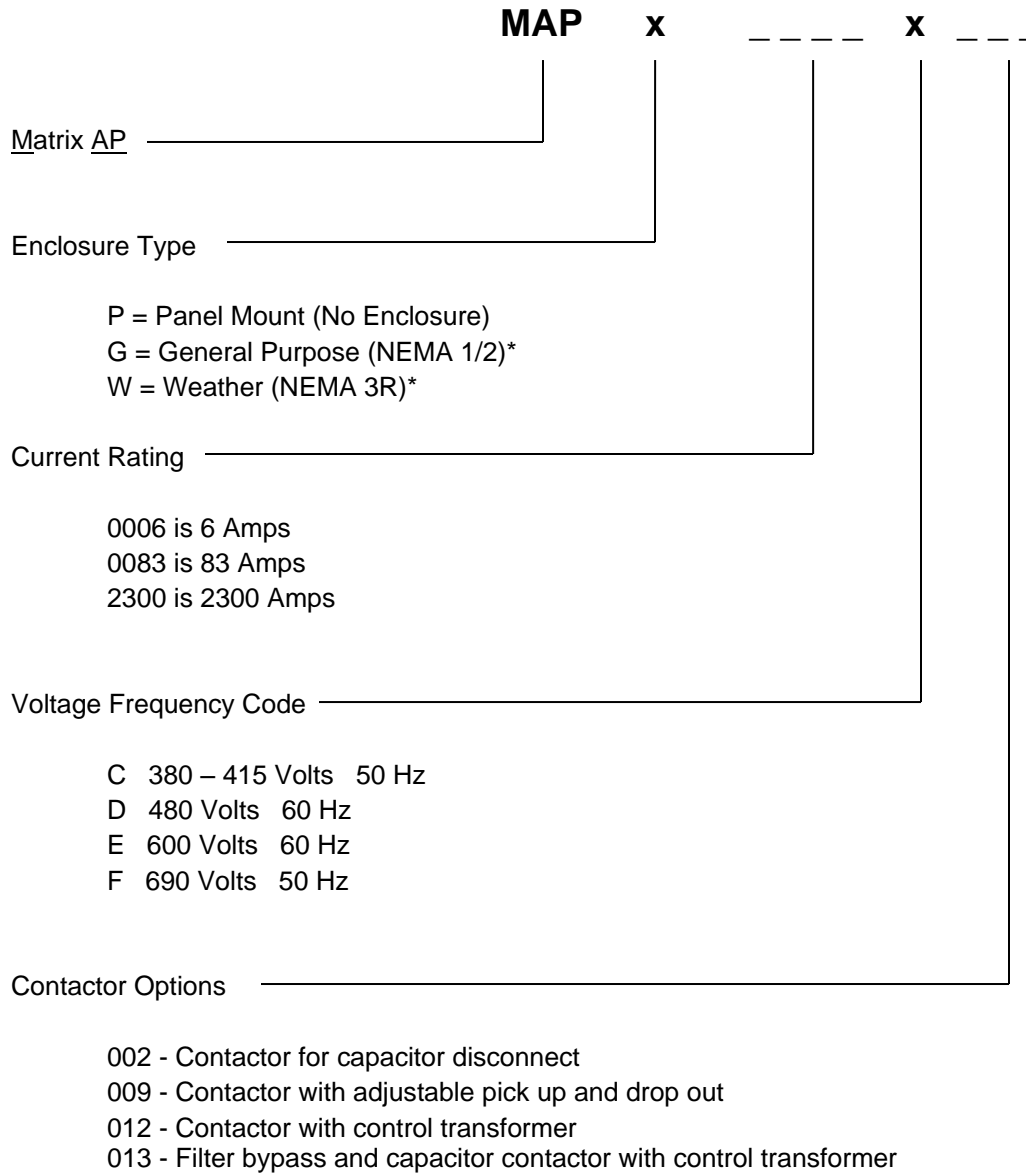

**Additional Options**

Option - 400  
Standard NEMA 3R enclosure with optional rodent/serpent screen  
Option 400 provides intake exhaust air screens with (¼ x ¼) mesh  
\*Not available on units 1600A (480V) and above

## Matrix AP 400 Volts, 50Hz Part Number Selection Tables Open Panel

Table 3-1: Matrix AP 400V Open Panel

Filter Amps Rating	Part Number	App. Wt. (lbs.)	HMR Size (in.) (H x W x D)	HMR Ref. Fig.	Cap-panel P/N	3-Phase Capacitor (in.) (H x D) Capacitor Panel (in.) (H x W x D)	Capacitor Ref. Fig.
6	MAPP0006C	16	8.7 x 8.0 x 5.5	<a href="#">A-1 (p57)</a>	CAP-350TP	7.5 x 2.9	<a href="#">A-13 (p69)</a>
8	MAPP0008C	17	8.7 x 8.0 x 5.5	<a href="#">A-1 (p57)</a>	CAP-351TP	7.5 x 2.9	<a href="#">A-13 (p69)</a>
11	MAPP0011C	26	9.9 x 9.0 x 4.8	<a href="#">A-1 (p57)</a>	CAP-352TP	7.5 x 2.9	<a href="#">A-13 (p69)</a>
14	MAPP0014C	30	9.8 x 9.0 x 5.3	<a href="#">A-1 (p57)</a>	CAP-353TP	7.5 x 3.9	<a href="#">A-13 (p69)</a>
21	MAPP0021C	47	11.7 x 10.5 x 6.6	<a href="#">A-1 (p57)</a>	CAP-342TP	7.5 x 3.9	<a href="#">A-13 (p69)</a>
27	MAPP0027C	52	11.7 x 10.5 x 7.0	<a href="#">A-1 (p57)</a>	CAP-354TP	7.5 x 4.6	<a href="#">A-13 (p69)</a>
34	MAPP0034C	62	11.7 x 10.5 x 7.6	<a href="#">A-1 (p57)</a>	CAP-355TP	9.1 x 4.6	<a href="#">A-13 (p69)</a>
44	MAPP0044C	74	11.7 x 10.5 x 8.0	<a href="#">A-1 (p57)</a>	CAP-356TP	9.1 x 4.6	<a href="#">A-13 (p69)</a>
52	MAPP0052C	94	14.0 x 12.0 x 9.0	<a href="#">A-3 (p59)</a>	CAP-357TP	10.6 x 4.6	<a href="#">A-13 (p69)</a>
66	MAPP0066C	107	14.0 x 12.0 x 9.0	<a href="#">A-3 (p59)</a>	CAP-358TP	10.6 x 4.6	<a href="#">A-13 (p69)</a>
83	MAPP0083C	135	14.0 x 12.0 x 10.9	<a href="#">A-3 (p59)</a>	CAP-359TP	10.6 x 4.6	<a href="#">A-13 (p69)</a>
103	MAPP0103C	145	14.0 x 12.0 x 10.8	<a href="#">A-3 (p59)</a>	CAP-360TP	10.6 x 4.6	<a href="#">A-13 (p69)</a>
128	MAPP0128C	165	20.0 x 15.3 x 10.7	<a href="#">A-5 (p61)</a>	594	6.9 x 16.3 x 7.6	<a href="#">A-14 (p70)</a>
165	MAPP0165C	223	20.0 x 15.3 x 11.8	<a href="#">A-5 (p61)</a>	544	7.9 x 16.3 x 7.6	<a href="#">A-14 (p70)</a>
208	MAPP0208C	237	20.0 x 15.3 x 11.9	<a href="#">A-5 (p61)</a>	543	8.9 x 16.3 x 7.6	<a href="#">A-14 (p70)</a>
240	MAPP0240C	327	20.0 x 15.3 x 12.8	<a href="#">A-5 (p61)</a>	595	7.9 x 16.3 x 7.6	<a href="#">A-14 (p70)</a>
320	MAPP0320C	390	20.0 x 15.3 x 14.8	<a href="#">A-5 (p61)</a>	596	10.7 x 16.3 x 7.6	<a href="#">A-14 (p70)</a>
403	MAPP0403C	433	23.3 x 15.3 x 13.9	<a href="#">A-7 (p63)</a>	597	11.5 x 16.3 x 7.6	<a href="#">A-14 (p70)</a>
482	MAPP0482C	483	23.3 x 15.3 x 14.8	<a href="#">A-7 (p63)</a>	595	7.9 x 16.3 x 7.6	<a href="#">A-14 (p70)</a>
					595	7.9 x 16.3 x 7.6	<a href="#">A-14 (p70)</a>
636	MAPP0636C	736	26.0 x 2.04 x 16.5	<a href="#">A-11 (p67)</a>	596	10.7 x 16.3 x 7.6	<a href="#">A-14 (p70)</a>
					596	10.7 x 16.3 x 7.6	<a href="#">A-14 (p70)</a>
786	MAPP0786C	911	26.0 x 24.0 x 17.8	<a href="#">A-11 (p67)</a>	597	11.5 x 16.3 x 7.6	<a href="#">A-14 (p70)</a>
					597	11.5 x 16.3 x 7.6	<a href="#">A-14 (p70)</a>
850	MAPP0850C	983	26.0 x 24.0 x 20.3	<a href="#">A-11 (p67)</a>	596	10.7 x 16.3 x 7.6	<a href="#">A-14 (p70)</a>
					596	10.7 x 16.3 x 7.6	<a href="#">A-14 (p70)</a>
					595	7.9 x 16.3 x 7.6	<a href="#">A-14 (p70)</a>
1000	MAPP1000C	1137	26.0 x 24.0 x 21.7	<a href="#">A-11 (p67)</a>	598	10.7 x 16.3 x 7.6	<a href="#">A-14 (p70)</a>
					598	10.7 x 16.3 x 7.6	<a href="#">A-14 (p70)</a>
					598	10.7 x 16.3 x 7.6	<a href="#">A-14 (p70)</a>
1200	MAPP1200C	1297	26.0 x 24.0 x 22.2	<a href="#">A-11 (p67)</a>	597	11.5 x 16.3 x 7.6	<a href="#">A-14 (p70)</a>
					597	11.5 x 16.3 x 7.6	<a href="#">A-14 (p70)</a>
					597	11.5 x 16.3 x 7.6	<a href="#">A-14 (p70)</a>

## Matrix AP 400 Volts, 50Hz Part Number Selection Tables Enclosed

Table 3-2: Matrix AP 400V Enclosed

Filter Amps Rating	NEMA 1/2	Enclosure	App. Weight (lbs.)	NEMA 3R	Enclosure	App. Weight (lbs.)	Ref. Fig.
6	<b>MAPG0006C</b>	CAB-12AP2	65	<b>MAPW0006C</b>	CAB-12AP3	73	<a href="#">A-15 (p71)</a>
8	<b>MAPG0008C</b>	CAB-12AP2	65	<b>MAPW0008C</b>	CAB-12AP3	73	<a href="#">A-15 (p71)</a>
11	<b>MAPG0011C</b>	CAB-12AP2	75	<b>MAPW0011C</b>	CAB-12AP3	82	<a href="#">A-15 (p71)</a>
14	<b>MAPG0014C</b>	CAB-12AP2	81	<b>MAPW0014C</b>	CAB-12AP3	88	<a href="#">A-15 (p71)</a>
21	<b>MAPG0021C</b>	CAB-12AP2	97	<b>MAPW0021C</b>	CAB-12AP3	105	<a href="#">A-15 (p71)</a>
27	<b>MAPG0027C</b>	CAB-12AP2	104	<b>MAPW0027C</b>	CAB-12AP3	111	<a href="#">A-15 (p71)</a>
34	<b>MAPG0034C</b>	CAB-12AP2	115	<b>MAPW0034C</b>	CAB-12AP3	123	<a href="#">A-15 (p71)</a>
44	<b>MAPG0044C</b>	CAB-12AP2	127	<b>MAPW0044C</b>	CAB-12AP3	135	<a href="#">A-15 (p71)</a>
52	<b>MAPG0052C</b>	CAB-17AP2	174	<b>MAPW0052C</b>	CAB-17AP3	181	<a href="#">A-16 (p72)</a>
66	<b>MAPG0066C</b>	CAB-17AP2	186	<b>MAPW0066C</b>	CAB-17AP3	194	<a href="#">A-16 (p72)</a>
83	<b>MAPG0083C</b>	CAB-17AP2	210	<b>MAPW0083C</b>	CAB-17AP3	217	<a href="#">A-16 (p72)</a>
103	<b>MAPG0103C</b>	CAB-17AP2	221	<b>MAPW0103C</b>	CAB-17AP3	228	<a href="#">A-16 (p72)</a>
128	<b>MAPG0128C</b>	CAB-26AP2	361	<b>MAPW0128C</b>	CAB-26AP3	374	<a href="#">A-17 (p73)</a>
165	<b>MAPG0165C</b>	CAB-26AP2	429	<b>MAPW0165C</b>	CAB-26AP3	442	<a href="#">A-17 (p73)</a>
208	<b>MAPG0208C</b>	CAB-26AP2	444	<b>MAPW0208C</b>	CAB-26AP3	457	<a href="#">A-17 (p73)</a>
240	<b>MAPG0240C</b>	CAB-26AP2	476	<b>MAPW0240C</b>	CAB-26AP3	489	<a href="#">A-17 (p73)</a>
320	<b>MAPG0320C</b>	CAB-26APD2	643	<b>MAPW0320C</b>	CAB-26APD3	675	<a href="#">A-18 (p74)</a>
403	<b>MAPG0403C</b>	CAB-26APD2	637	<b>MAPW0403C</b>	CAB-26APD3	669	<a href="#">A-18 (p74)</a>
482	<b>MAPG0482C</b>	CAB-42AP2	734	<b>MAPW0482C</b>	CAB-42AP3	739	<a href="#">A-19 (p75)</a>
636	<b>MAPG0636C</b>	CAB-42AP2	1111	<b>MAPW0636C</b>	CAB-42AP3	1116	<a href="#">A-19 (p75)</a>
786	<b>MAPG0786C</b>	CAB-42AP2	1260	<b>MAPW0786C</b>	CAB-42AP3	1264	<a href="#">A-19 (p75)</a>
850	<b>MAPG0850C</b>	CAB48AP2	1685	<b>MAPW0850C</b>	CAB-48AP3	1726	<a href="#">A-20 (p76)</a>
1000	<b>MAPG1000C</b>	CAB48AP2	1837	<b>MAPW1000C</b>	CAB-48AP3	1878	<a href="#">A-20 (p76)</a>
1200	<b>MAPG1200C</b>	CAB48AP2	1883	<b>MAPW1200C</b>	CAB-48AP3	1924	<a href="#">A-20 (p76)</a>

## Filter Efficiency + Watt loss Matrix AP 400V, 50Hz

**Table 3-3: Watt Loss - Matrix AP 400V, 50Hz**

Maximum Output Amps RMS	Efficiency (Typical) (%)	400V Power Dissipation @ Rated Current (Typical) (Watts)	Capacitor Current 400V (Typical) Amps RMS
6	97.5%	114	2.145
8	97.6%	149	3.52
11	97.9%	180	4.84
14	98.1%	206	5.39
21	98.6%	235	7.48
27	98.7%	266	10.23
34	98.8%	298	13.145
44	98.9%	356	15.983
52	99.0%	388	19.25
66	99.1%	459	24.904
83	99.1%	565	31.196
103	99.2%	660	38.071
128	99.0%	973	43.978
165	99.2%	1,030	55.033
208	99.2%	1,263	72.666
240	99.2%	1,423	80.63
320	99.4%	1,450	104.709
403	99.4%	1,816	138.82
482	99.5%	2,008	157.553
636	99.5%	2,359	218.581
786	99.6%	2,604	271.865
850	99.6%	2,974	299.255
1000	99.5%	3,954	341.11
1200	99.6%	4,136	420

**Note: Use the IEC AC-3 rating for the corresponding filter capacitor current when selecting a contactor.**

## Matrix AP 400 Volts, 50Hz Mounting Patterns

**Table 3-4: Matrix AP 400V HMR Bolt Hole Mounting Patterns**

Part Number	App. Wt. (lbs.)	Overall Size (in.) (H x W x D)	Rear Mount Centerline	Base Mount Centerline	Mounting Holes	Ref. Fig.
MAPP0006C	16	8.7 x 8.0 x 5.5	7.0"A x 7.2"B	2.8"C x 7.2"E	.28" DIA	<a href="#">A-1 (p57)</a>
MAPP0008C	17	8.7 x 8.0 x 5.5	7.0"A x 7.2"B	2.8"C x 7.2"E	.28" DIA	<a href="#">A-1 (p57)</a>
MAPP0011C	26	9.9 x 9.0 x 4.8	8.2"A x 8.2"B	2.8"C x 8.2"E	.28" DIA	<a href="#">A-1 (p57)</a>
MAPP0014C	30	9.8 x 9.0 x 5.3	8.2"A x 8.2"B	3.3"C x 8.2"E	.28" DIA	<a href="#">A-1 (p57)</a>
MAPP0021C	47	11.7 x 10.5 x 6.6	9.8"A x 9.7"B	3.5"C x 9.7"E	.28" DIA	<a href="#">A-1 (p57)</a>
MAPP0027C	52	11.7 x 10.5 x 7.0	9.9"A x 9.7"B	4.0"C x 9.7"E	.28" DIA	<a href="#">A-1 (p57)</a>
MAPP0034C	62	11.7 x 10.5 x 7.6	9.8"A x 9.7"B	4.5"C x 9.7"E	.28" DIA	<a href="#">A-1 (p57)</a>
MAPP0044C	74	11.7 x 10.5 x 8.0	9.8"A x 9.7"B	5.0"C x 9.7"E	.28" DIA	<a href="#">A-1 (p57)</a>
MAPP0052C	94	14.0 x 12.0 x 9.0	12.0"A x 11.0"B	5.4"C x 11.0"E	.34" DIA	<a href="#">A-3 (p59)</a>
MAPP0066C	107	14.0 x 12.0 x 9.0	12.0"A x 11.0"B	5.9"C x 11.0"E	.340 DIA	<a href="#">A-3 (p59)</a>
MAPP0083C	133	14.0 x 12.0 x 10.9	12.0"A x 11.0"B	6.5"C x 11.0"E	.34" DIA	<a href="#">A-3 (p59)</a>
MAPP0103C	144	14.0 x 12.0 x 10.8	12.1"A x 11.0"B	6.5"C x 11.0"E	.34" DIA	<a href="#">A-3 (p59)</a>
MAPP0128C	149	20.0 x 15.3 x 10.7	17.4"A x 14.0"B	6.0"C x 14.0"E	.41" DIA	<a href="#">A-5 (p61)</a>
MAPP0165C	257	20.0 x 15.3 x 11.8	17.3"A x 14.0"B	7.0"C x 14.0"E	.41" DIA	<a href="#">A-5 (p61)</a>
MAPP0208C	270	20.0 x 15.3 x 11.9	17.5"A x 14.0"B	7.0"C x 14.0"E	.41" DIA	<a href="#">A-5 (p61)</a>
MAPP0240C	310	20.0 x 15.3 x 12.8	17.5"A x 14.0"B	8.0"C x 14.0"E	.41" DIA	<a href="#">A-5 (p61)</a>
MAPP0320C	397	20.0 x 15.3 x 14.8	17.2"A x 14.0"B	10.0"C x 14.0"E	.41" DIA	<a href="#">A-5 (p61)</a>
MAPP0403C	433	23.3 x 15.3 x 13.9	20.6"A x 14.0"B	9.2"C x 14.0"E	.41" DIA	<a href="#">A-7 (p63)</a>
MAPP0482C	483	23.3 x 15.3 x 14.8	20.6"A x 14.0"B	10.1"C x 14.0"E	.41" DIA	<a href="#">A-7 (p63)</a>
MAPP0636C	793	26.0 x 24.0 x 16.5	N/A	9.2"C x 22.0"E	1.0" DIA	<a href="#">A-11 (p67)</a>
MAPP0786C	970	26.0 x 24.0 x 17.8	N/A	10.7"C x 22.0"E	1.0" DIA	<a href="#">A-11 (p67)</a>
MAPP0850C	1070	26.0 x 24.0 x 20.0	N/A	10.7"C x 22.0"E	1.0" DIA	<a href="#">A-11 (p67)</a>
MAPP1000C	1213	26.0 x 24.0 x 21.7	N/A	12.2"C x 22.0"E	1.0" DIA	<a href="#">A-11 (p67)</a>
MAPP1200C	1365	26.0 x 24.0 x 22.2	N/A	13.7"C x 22.0"E	1.0" DIA	<a href="#">A-11 (p67)</a>

## Matrix AP 400 Volts, 50Hz Capacitor and Cap-panel Bolt Hole Mounting Patterns

**Table 3-5: Matrix AP 400V Capacitor and Cap-panel Bolt Hole Mounting Patterns**

Part Number	Cap-panel P/N	App. Weight (lbs.)	Overall Size (in.) (H x W x D)	Rear Mount Centerline	Mounting Holes	Ref. Fig.
MAPP0006C	CAP-350TP	1.8	7.5 x 2.9	N/A	M12 STUD	<a href="#">A-13 (p69)</a>
MAPP0008C	CAP-351TP	2.2	7.5 x 2.9	N/A	M12 STUD	<a href="#">A-13 (p69)</a>
MAPP0011C	CAP-352TP	2.3	7.5 x 2.9	N/A	M12 STUD	<a href="#">A-13 (p69)</a>
MAPP0014C	CAP-353TP	2.64	7.5 x 3.9	N/A	M12 STUD	<a href="#">A-13 (p69)</a>
MAPP0021C	CAP-342TP	3.2	7.5 x 3.9	N/A	M12 STUD	<a href="#">A-13 (p69)</a>
MAPP0027C	CAP-354TP	4.0	7.5 x 4.6	N/A	M12 STUD	<a href="#">A-13 (p69)</a>
MAPP0034C	CAP-355TP	4.1	9.1 x 4.6	N/A	M12 STUD	<a href="#">A-13 (p69)</a>
MAPP0044C	CAP-356TP	5.0	9.1 x 4.6	N/A	M12 STUD	<a href="#">A-13 (p69)</a>
MAPP0052C	CAP-357TP	6.0	10.6 x 4.6	N/A	M12 STUD	<a href="#">A-13 (p69)</a>
MAPP0066C	CAP-358TP	6.0	10.6 x 4.6	N/A	M12 STUD	<a href="#">A-13 (p69)</a>
MAPP0083C	CAP-359TP	6.45	10.6 x 4.6	N/A	M12 STUD	<a href="#">A-13 (p69)</a>
MAPP0103C	CAP-360TP	6.45	10.6 x 4.6	N/A	M12 STUD	<a href="#">A-13 (p69)</a>
MAPP0128C	594	16	6.9 x 16.3 x 7.6	3.8"A x 15.8"B	.28" DIA	<a href="#">A-14 (p70)</a>
MAPP0165C	544	18	7.9 x 16.3 x 7.6	3.8"A x 15.8"B	.28" DIA	<a href="#">A-14 (p70)</a>
MAPP0208C	543	20	8.9 x 16.3 x 7.6	3.8"A x 15.8"B	.28" DIA	<a href="#">A-14 (p70)</a>
MAPP0240C	595	18	7.9 x 16.3 x 7.6	3.8"A x 15.8"B	.28" DIA	<a href="#">A-14 (p70)</a>
MAPP0320C	596	23	10.7" x 16.3 x 7.6	3.8"A x 15.8"B	.28" DIA	<a href="#">A-14 (p70)</a>
MAPP0403C	597	23	11.5" x 16.3" x 7.6	3.8"A x 15.8"B	.28" DIA	<a href="#">A-14 (p70)</a>
MAPP0482C	595	18	7.9 x 16.3 x 7.6	3.8"A x 15.8"B	.28" DIA	<a href="#">A-14 (p70)</a>
	595	18	7.9 x 16.3 x 7.6	3.8"A x 15.8"B	.28" DIA	<a href="#">A-14 (p70)</a>
MAPP0636C	596	23	10.7" x 16.3 x 7.6	3.8"A x 15.8"B	.28" DIA	<a href="#">A-14 (p70)</a>
	596	23	10.7" x 16.3 x 7.6	3.8"A x 15.8"B	.28" DIA	<a href="#">A-14 (p70)</a>
MAPP0786C	597	23	11.5" x 16.3" x 7.6	3.8"A x 15.8"B	.28" DIA	<a href="#">A-14 (p70)</a>
	597	23	11.5" x 16.3" x 7.6	3.8"A x 15.8"B	.28" DIA	<a href="#">A-14 (p70)</a>
MAPP0850C	596	23	10.7" x 16.3 x 7.6	3.8"A x 15.8"B	.28" DIA	<a href="#">A-14 (p70)</a>
	596	23	10.7" x 16.3 x 7.6	3.8"A x 15.8"B	.28" DIA	<a href="#">A-14 (p70)</a>
	595	18	7.9 x 16.3 x 7.6	3.8"A x 15.8"B	.28" DIA	<a href="#">A-14 (p70)</a>
MAPP1000C	598	23	10.7" x 16.3 x 7.6	3.8"A x 15.8"B	.28" DIA	<a href="#">A-14 (p70)</a>
	598	23	10.7" x 16.3 x 7.6	3.8"A x 15.8"B	.28" DIA	<a href="#">A-14 (p70)</a>
	598	23	10.7" x 16.3" x 7.6	3.8"A x 15.8"B	.28" DIA	<a href="#">A-14 (p70)</a>
MAPP1200C	597	23	11.5" x 16.3" x 7.6	3.8"A x 15.8"B	.28" DIA	<a href="#">A-14 (p70)</a>
	597	23	11.5" x 16.3" x 7.6	3.8"A x 15.8"B	.28" DIA	<a href="#">A-14 (p70)</a>
	597	23	11.5" x 16.3" x 7.6	3.8"A x 15.8"B	.28" DIA	<a href="#">A-14 (p70)</a>

**Note: Units above 403 amps require multiple parallel cap panels.**

**Use the above table and referenced figures to establish suitable Cap-panel mounting.**

## Matrix AP 480 Volts, 60Hz Part Number Selection Tables Open Panel

Table 3-6: Matrix AP 480V Open Panel

Filter Amps Rating	Part Number	App. Wt. (lbs.)	HMR Size (in.) (H x W x D)	HMR Ref. Fig.	Cap-panel P/N	3-Phase Capacitor (in.) (H x D) Capacitor Panel (in.) (H x W x D)	Cap. Ref. Fig.
6	MAPP0006D	16	8.7 x 8.0 x 5.5	<a href="#">A-1 (p57)</a>	CAP-338TP	7.5 x 2.9	<a href="#">A-13 (p69)</a>
8	MAPP0008D	17	8.7 x 8.0 x 5.5	<a href="#">A-1 (p57)</a>	CAP-339TP	7.5 x 2.9	<a href="#">A-13 (p69)</a>
11	MAPP0011D	26	9.9 x 9.0 x 4.8	<a href="#">A-1 (p57)</a>	CAP-349TP	7.5 x 2.9	<a href="#">A-13 (p69)</a>
14	MAPP0014D	30	9.8 x 9.0 x 5.3	<a href="#">A-1 (p57)</a>	CAP-340TP	7.5 x 2.9	<a href="#">A-13 (p69)</a>
21	MAPP0021D	47	11.7 x 10.5 x 6.6	<a href="#">A-1 (p57)</a>	CAP-341TP	7.5 x 3.9	<a href="#">A-13 (p69)</a>
27	MAPP0027D	52	11.7 x 10.5 x 7.0	<a href="#">A-1 (p57)</a>	CAP-342TP	7.5 x 3.9	<a href="#">A-13 (p69)</a>
34	MAPP0034D	62	11.7 x 10.5 x 7.6	<a href="#">A-1 (p57)</a>	CAP-343TP	7.5 x 3.9	<a href="#">A-13 (p69)</a>
44	MAPP0044D	74	11.7 x 10.5 x 8.0	<a href="#">A-1 (p57)</a>	CAP-344TP	7.5 x 4.6	<a href="#">A-13 (p69)</a>
52	MAPP0052D	94	14.0 x 12.0 x 9.0	<a href="#">A-3 (p59)</a>	CAP-345TP	9.2 x 4.6	<a href="#">A-13 (p69)</a>
66	MAPP0066D	107	14.0 x 12.0 x 9.0	<a href="#">A-3 (p59)</a>	CAP-346TP	9.2 x 4.6	<a href="#">A-13 (p69)</a>
83	MAPP0083D	135	14.0 x 12.0 x 10.9	<a href="#">A-3 (p59)</a>	CAP-347TP	10.6 x 4.6	<a href="#">A-13 (p69)</a>
103	MAPP0103D	145	14.0 x 12.0 x 10.8	<a href="#">A-3 (p59)</a>	CAP-348TP	10.6 x 4.6	<a href="#">A-13 (p69)</a>
128	MAPP0128D	165	20.0 x 15.3 x 10.7	<a href="#">A-5 (p61)</a>	555	6.9 x 16.3 x 7.6	<a href="#">A-14 (p70)</a>
165	MAPP0165D	223	20.0 x 15.3 x 11.8	<a href="#">A-5 (p61)</a>	557	6.9 x 16.3 x 7.6	<a href="#">A-14 (p70)</a>
208	MAPP0208D	237	20.0 x 15.3 x 11.8	<a href="#">A-5 (p61)</a>	545	7.9 x 16.3 x 7.6	<a href="#">A-14 (p70)</a>
240	MAPP0240D	327	20.0 x 15.3 x 12.8	<a href="#">A-5 (p61)</a>	544	7.9 x 16.3 x 7.6	<a href="#">A-14 (p70)</a>
320	MAPP0320D	390	20.0 x 15.3 x 14.8	<a href="#">A-5 (p61)</a>	543	8.9 x 16.3 x 7.6	<a href="#">A-14 (p70)</a>
403	MAPP0403D	433	23.3 x 15.3 x 13.9	<a href="#">A-7 (p63)</a>	562	10.7 x 16.3 x 7.6	<a href="#">A-14 (p70)</a>
482	MAPP0482D	483	23.3 x 15.3 x 14.8	<a href="#">A-7 (p63)</a>	544	7.9 x 16.3 x 7.6	<a href="#">A-14 (p70)</a>
					544	7.9 x 16.3 x 7.6	<a href="#">A-14 (p70)</a>
636	MAPP0636D	736	26.0 x 24.0 x 16.5	<a href="#">A-11 (p67)</a>	543	8.9 x 16.3 x 7.6	<a href="#">A-14 (p70)</a>
					543	8.9 x 16.3 x 7.6	<a href="#">A-14 (p70)</a>
786	MAPP0786D	911	26.0 x 24.0 x 17.8	<a href="#">A-11 (p67)</a>	562	10.7 x 16.3 x 7.6	<a href="#">A-14 (p70)</a>
					562	10.7 x 16.3 x 7.6	<a href="#">A-14 (p70)</a>
850	MAPP0850D	983	26.0 x 24.0 x 20.3	<a href="#">A-11 (p67)</a>	543	8.9 x 16.3 x 7.6	<a href="#">A-14 (p70)</a>
					543	8.9 x 16.3 x 7.6	<a href="#">A-14 (p70)</a>
					544	7.9 x 16.3 x 7.6	<a href="#">A-14 (p70)</a>
1000	MAPP1000D	1137	26.0 x 24.0 x 21.7	<a href="#">A-11 (p67)</a>	543	8.9 x 16.3 x 7.6	<a href="#">A-14 (p70)</a>
					543	8.9 x 16.3 x 7.6	<a href="#">A-14 (p70)</a>
					561	10.7 x 16.3 x 7.6	<a href="#">A-14 (p70)</a>
1200	MAPP1200D	1297	26.0 x 24.0 x 22.2	<a href="#">A-11 (p67)</a>	562	10.7 x 16.3 x 7.6	<a href="#">A-14 (p70)</a>
					562	10.7 x 16.3 x 7.6	<a href="#">A-14 (p70)</a>
					562	10.7 x 16.3 x 7.6	<a href="#">A-14 (p70)</a>

### Matrix AP 480 Volts, 60Hz Part Number Selection Tables Open Panel (Continued)

Table 3-6 Continued: Matrix AP 480V Open Panel

Filter Amps Rating	Part Number	App. Wt. (lbs.)	HMR Size (in.) (H x W x D)	HMR Ref. Fig.	Cap-panel P/N	3-Phase Capacitor (in.) (H x D) Capacitor Panel (in.) (H x W x D)	Cap. Ref. Fig.
1600	MAPP1600D	1970	34.7 x 36.0 x 29.2	<a href="#">A-12 (p68)</a>	563	10.7 x 16.3 x 7.6	<a href="#">A-14 (p70)</a>
					563	10.7 x 16.3 x 7.6	<a href="#">A-14 (p70)</a>
					563	10.7 x 16.3 x 7.6	<a href="#">A-14 (p70)</a>
					563	10.7 x 16.3 x 7.6	<a href="#">A-14 (p70)</a>
2000	MAPP2000D	2347	35.0 x 36.0 x 31.0	<a href="#">A-12 (p68)</a>	563	10.7 x 16.3 x 7.6	<a href="#">A-14 (p70)</a>
					563	10.7 x 16.3 x 7.6	<a href="#">A-14 (p70)</a>
					563	10.7 x 16.3 x 7.6	<a href="#">A-14 (p70)</a>
					563	10.7 x 16.3 x 7.6	<a href="#">A-14 (p70)</a>
					563	10.7 x 16.3 x 7.6	<a href="#">A-14 (p70)</a>
2300	MAPP2300D	2541	34.5 x 36.0 x 32.3	<a href="#">A-12 (p68)</a>	562	10.7 x 16.3 x 7.6	<a href="#">A-14 (p70)</a>
					562	10.7 x 16.3 x 7.6	<a href="#">A-14 (p70)</a>
					562	10.7 x 16.3 x 7.6	<a href="#">A-14 (p70)</a>
					562	10.7 x 16.3 x 7.6	<a href="#">A-14 (p70)</a>
					562	10.7 x 16.3 x 7.6	<a href="#">A-14 (p70)</a>
					562	10.7 x 16.3 x 7.6	<a href="#">A-14 (p70)</a>



## Matrix AP 480 Volts, 60Hz Part Number Selection Tables Enclosed

Table 3-7: Matrix AP 480V Enclosed

Filter Amps Rating	NEMA 1/2	Enclosure	App. Weight (lbs.)	NEMA 3R	Enclosure	App. Weight (lbs.)	Ref. Fig.
6	MAPG0006D	CAB-12AP2	64	MAPW0006D	CAB-12AP3	72	<a href="#">A-15 (p71)</a>
8	MAPG0008D	CAB-12AP2	65	MAPW0008D	CAB-12AP3	73	<a href="#">A-15 (p71)</a>
11	MAPG0011D	CAB-12AP2	74	MAPW0011D	CAB-12AP3	82	<a href="#">A-15 (p71)</a>
14	MAPG0014D	CAB-12AP2	79	MAPW0014D	CAB-12AP3	87	<a href="#">A-15 (p71)</a>
21	MAPG0021D	CAB-12AP2	97	MAPW0021D	CAB-12AP3	105	<a href="#">A-15 (p71)</a>
27	MAPG0027D	CAB-12AP2	101	MAPW0027D	CAB-12AP3	109	<a href="#">A-15 (p71)</a>
34	MAPG0034D	CAB-12AP2	112	MAPW0034D	CAB-12AP3	120	<a href="#">A-15 (p71)</a>
44	MAPG0044D	CAB-12AP2	125	MAPW0044D	CAB-12AP3	133	<a href="#">A-15 (p71)</a>
52	MAPG0052D	CAB-17AP2	172	MAPW0052D	CAB-17AP3	179	<a href="#">A-16 (p72)</a>
66	MAPG0066D	CAB-17AP2	185	MAPW0066D	CAB-17AP3	192	<a href="#">A-16 (p72)</a>
83	MAPG0083D	CAB-17AP2	209	MAPW0083D	CAB-17AP3	217	<a href="#">A-16 (p72)</a>
103	MAPG0103D	CAB-17AP2	313	MAPW0103D	CAB-17AP3	321	<a href="#">A-16 (p72)</a>
128	MAPG0128D	CAB-26AP2	333	MAPW0128D	CAB-26AP3	347	<a href="#">A-17 (p73)</a>
165	MAPG0165D	CAB-26AP2	392	MAPW0165D	CAB-26AP3	406	<a href="#">A-17 (p73)</a>
208	MAPG0208D	CAB-26AP2	405	MAPW0208D	CAB-26AP3	419	<a href="#">A-17 (p73)</a>
240	MAPG0240D	CAB-26AP2	489	MAPW0240D	CAB-26AP3	503	<a href="#">A-17 (p73)</a>
320	MAPG0320D	CAB-26APD2	630	MAPW0320D	CAB-26APD3	656	<a href="#">A-18 (p74)</a>
403	MAPG0403D	CAB-26APD2	673	MAPW0403D	CAB-26APD3	700	<a href="#">A-18 (p74)</a>
482	MAPG0482D	CAB-42AP2	702	MAPW0482D	CAB-42AP3	710	<a href="#">A-19 (p75)</a>
636	MAPG0636D	CAB-42AP2	1077	MAPW0636D	CAB-42AP3	1084	<a href="#">A-19 (p75)</a>
786	MAPG0786D	CAB-42AP2	1252	MAPW0786D	CAB-42AP3	1260	<a href="#">A-19 (p75)</a>
850	MAPG0850D	CAB48AP2	1386	MAPW0850D	CAB-48AP3	1393	<a href="#">A-20 (p76)</a>
1000	MAPG1000D	CAB48AP2	1640	MAPW1000D	CAB-48AP3	1647	<a href="#">A-20 (p76)</a>
1200	MAPG1200D	CAB48AP2	1700	MAPW1200D	CAB-48AP3	1707	<a href="#">A-20 (p76)</a>

## Filter Efficiency + Watt loss Matrix AP 480V, 60Hz

Table 3-8: Watt Loss - Matrix AP 480V, 60Hz

Maximum Output Amps RMS	Efficiency (Typical) (%)	480V Power Dissipation @ Rated Current (Typical) (Watts)	Capacitor Current 480V (Typical) Amps RMS
6	97.5%	122	1.98
8	97.6%	158	2.64
11	97.9%	192	3.7
14	98.1%	220	4.62
21	98.6%	251	6.93
27	98.7%	283	9.24
34	98.8%	318	11.8
44	98.9%	379	14.52
52	99.0%	413	17.16
66	99.1%	488	22.16
83	99.1%	600	29.2
103	99.2%	702	34.7
128	99.0%	1,035	39.8
165	99.2%	1,096	53.2
208	99.2%	1,343	64.8
240	99.2%	1,514	72.7
320	99.4%	1,543	94.5
403	99.4%	1,932	132.3
482	99.5%	2,137	141.8
636	99.5%	2,509	195.6
786	99.6%	2,771	245.0
850	99.6%	3,163	265.9
1000	99.5%	4,206	308.6
1200	99.6%	4,400	355.2
1600	99.4%	4,500	496.5
2000	99.4%	5,050	696.5
2300	99.4%	6,100	716.0

**Note:** Use the IEC AC-3 rating for the corresponding filter capacitor current when selecting a contactor.

## Matrix AP 480 Volts, 60Hz Mounting Patterns

Table 3-9: Matrix AP 480V Mounting Patterns

Part Number	App. Wt. (lbs.)	Overall Size (in.) (H x W x D)	Rear Mount Centerline	Base Mount Centerline	Mounting Holes	Ref. Fig.
MAPP0006D	16	8.7 x 8.0 x 5.5	7.0"A x 7.2"B	2.8"C x 7.2"E	.28" DIA	<a href="#">A-1 (p57)</a>
MAPP0008D	17	8.7 x 8.0 x 5.5	7.0"A x 7.2"B	2.8"C x 7.2"E	.28" DIA	<a href="#">A-1 (p57)</a>
MAPP0011D	26	9.9 x 9.0 x 4.8	8.2"A x 8.2"B	2.8"C x 8.2"E	.28" DIA	<a href="#">A-1 (p57)</a>
MAPP0014D	30	9.8 x 9.0 x 5.3	8.2"A x 8.2"B	3.3"C x 8.2"E	.28" DIA	<a href="#">A-1 (p57)</a>
MAPP0021D	47	11.7 x 10.5 x 6.6	9.8"A x 9.7"B	3.5"C x 9.7"E	.28" DIA	<a href="#">A-1 (p57)</a>
MAPP0027D	52	11.7 x 10.5 x 7.0	9.9"A x 9.7"B	4.0"C x 9.7"E	.28" DIA	<a href="#">A-1 (p57)</a>
MAPP0034D	62	11.7 x 10.5 x 7.6	9.8"A x 9.7"B	4.5"C x 9.7"E	.28" DIA	<a href="#">A-1 (p57)</a>
MAPP0044D	74	11.7 x 10.5 x 8.0	9.8"A x 9.7"B	5.0"C x 9.7"E	.28" DIA	<a href="#">A-1 (p57)</a>
MAPP0052D	94	14.0 x 12.0 x 9.0	12.0"A x 11.0"B	5.4"C x 11.0"E	.34" DIA	<a href="#">A-3 (p59)</a>
MAPP0066D	107	14.0 x 12.0 x 9.0	12.0"A x 11.0"B	5.9"C x 11.0"E	.34" DIA	<a href="#">A-3 (p59)</a>
MAPP0083D	133	15.7 x 12.0 x 10.7	12.0"A x 11.0"B	6.5"C x 11.0"E	.34" DIA	<a href="#">A-3 (p59)</a>
MAPP0103D	144	15.7 x 12.0 x 11.1	12.1"A x 11.0"B	6.5"C x 11.0"E	.34" DIA	<a href="#">A-3 (p59)</a>
MAPP0128D	149	20.0 x 15.3 x 10.7	17.4"A x 14.0"B	6.0"C x 14.0"E	.41" DIA	<a href="#">A-5 (p61)</a>
MAPP0165D	257	20.0 x 15.3 x 11.8	17.3"A x 14.0"B	7.0"C x 14.0"E	.41" DIA	<a href="#">A-5 (p61)</a>
MAPP0208D	270	20.0 x 15.3 x 11.9	17.8"A x 14.0"B	7.0"C x 14.0"E	.41" DIA	<a href="#">A-5 (p61)</a>
MAPP0240D	310	20.0 x 15.3 x 12.8	17.5"A x 14.0"B	8.0"C x 14.0"E	.41" DIA	<a href="#">A-5 (p61)</a>
MAPP0320D	397	20.0 x 15.3 x 14.8	17.6"A x 14.0"B	10.0"C x 14.0"E	.41" DIA	<a href="#">A-5 (p61)</a>
MAPP0403D	433	23.3 x 15.3 x 13.9	20.6"A x 14.0"B	9.2"C x 14.0"E	.41" DIA	<a href="#">A-7 (p63)</a>
MAPP0482D	483	23.3 x 15.3 x 14.4	20.6"A x 14.0"B	10.1"C x 14.0"E	.41" DIA	<a href="#">A-7 (p63)</a>
MAPP0636D	793	26.0 x 24.0 x 16.5	N/A	9.2"C x 22.0"E	1.0" DIA	<a href="#">A-11 (p67)</a>
MAPP0786D	970	26.0 x 24.0 x 17.8	N/A	10.7"C x 22.0"E	1.0" DIA	<a href="#">A-11 (p67)</a>
MAPP0850D	1070	26.0 x 24.0 x 20.3	N/A	10.7"C x 22.0"E	1.0" DIA	<a href="#">A-11 (p67)</a>
MAPP1000D	1213	26.0 x 24.0 x 21.7	N/A	12.2"C x 22.0"E	1.0" DIA	<a href="#">A-11 (p67)</a>
MAPP1200D	1297	26.0 x 24.0 x 22.2	N/A	13.7"C x 22.0"E	1.0" DIA	<a href="#">A-12 (p68)</a>
MAPP1600D	1970	34.7 x 36.0 x 29.2	N/A	18.0"C x 22.5"E	1.0" DIA	<a href="#">A-12 (p68)</a>
MAPP2000D	2347	35.0 x 36.0 x 31.0	N/A	19.5"C x 22.5"E	1.0" DIA	<a href="#">A-12 (p68)</a>
MAPP2300D	2541	34.3 x 36.0 x 32.3	N/A	21.0"C x 22.5"E	1.0" DIA	<a href="#">A-12 (p68)</a>

## Matrix AP 480 Volts, 60Hz Capacitor and Cap-panel Bolt Hole Mounting Patterns

**Table 3-10: Matrix AP 480V Capacitor and Cap-panel Bolt Hole Mounting Patterns**

Part Number	Cap-panel P/N	App. Wt. (lbs.)	Overall Size (in.) (H x W x D)	Rear Mount Centerline	Mounting Holes	Ref. Fig.
MAPP0006D	CAP-338TP	1.8	7.5 x 2.9	N/A	M12 STUD	<a href="#">A-13 (p69)</a>
MAPP0008D	CAP-339TP	1.95	7.5 x 2.9	N/A	M12 STUD	<a href="#">A-13 (p69)</a>
MAPP0011D	CAP-349TP	2.1	7.5 x 2.9	N/A	M12 STUD	<a href="#">A-13 (p69)</a>
MAPP0014D	CAP-340TP	2.3	7.5 x 2.9	N/A	M12 STUD	<a href="#">A-13 (p69)</a>
MAPP0021D	CAP-341TP	2.65	7.5 x 3.9	N/A	M12 STUD	<a href="#">A-13 (p69)</a>
MAPP0027D	CAP-342TP	3.2	7.5 x 3.9	N/A	M12 STUD	<a href="#">A-13 (p69)</a>
MAPP0034D	CAP-343TP	3.7	7.5 x 3.9	N/A	M12 STUD	<a href="#">A-13 (p69)</a>
MAPP0044D	CAP-344TP	4.0	7.5 x 4.6	N/A	M12 STUD	<a href="#">A-13 (p69)</a>
MAPP0052D	CAP-345TP	4.1	9.2 x 4.6	N/A	M12 STUD	<a href="#">A-13 (p69)</a>
MAPP0066D	CAP-346TP	5.0	9.2 x 4.6	N/A	M12 STUD	<a href="#">A-13 (p69)</a>
MAPP0083D	CAP-347TP	6.0	10.6 x 4.6	N/A	M12 STUD	<a href="#">A-13 (p69)</a>
MAPP0103D	CAP-348TP	6.45	10.6 x 4.6	N/A	M12 STUD	<a href="#">A-13 (p69)</a>
MAPP0128D	555	16	6.9 x 16.3 x 7.6	3.8"A x 15.8"B	.28" DIA	<a href="#">A-14 (p70)</a>
MAPP0165D	557	16	6.9 x 16.3 x 7.6	3.8"A x 15.8"B	.28" DIA	<a href="#">A-14 (p70)</a>
MAPP0208D	545	18	7.9 x 16.3 x 7.6	3.8"A x 15.8"B	.28" DIA	<a href="#">A-14 (p70)</a>
MAPP0240D	544	18	7.9 x 16.3 x 7.6	3.8"A x 15.8"B	.28" DIA	<a href="#">A-14 (p70)</a>
MAPP0320D	543	20	8.9 x 16.3 x 7.6	3.8"A x 15.8"B	.28" DIA	<a href="#">A-14 (p70)</a>
MAPP0403D	562	23	10.7 x 16.3 x 7.6	3.8"A x 15.8"B	.28" DIA	<a href="#">A-14 (p70)</a>
MAPP0482D	544	18	7.9 x 16.3 x 7.6	3.8"A x 15.8"B	.28" DIA	<a href="#">A-14 (p70)</a>
	544	18	7.9 x 16.3 x 7.6	3.8"A x 15.8"B	.28" DIA	<a href="#">A-14 (p70)</a>
MAPP0636D	543	20	8.9 x 16.3 x 7.6	3.8"A x 15.8"B	.28" DIA	<a href="#">A-14 (p70)</a>
	543	20	8.9 x 16.3 x 7.6	3.8"A x 15.8"B	.28" DIA	<a href="#">A-14 (p70)</a>
MAPP0786D	562	23	10.7 x 16.3 x 7.6	3.8"A x 15.8"B	.28" DIA	<a href="#">A-14 (p70)</a>
	562	23	10.7 x 16.3 x 7.6	3.8"A x 15.8"B	.28" DIA	<a href="#">A-14 (p70)</a>
MAPP0850D	543	20	8.9 x 16.3 x 7.6	3.8"A x 15.8"B	.28" DIA	<a href="#">A-14 (p70)</a>
	543	20	8.9 x 16.3 x 7.6	3.8"A x 15.8"B	.28" DIA	<a href="#">A-14 (p70)</a>
	544	18	7.9 x 16.3 x 7.6	3.8"A x 15.8"B	.28" DIA	<a href="#">A-14 (p70)</a>
MAPP1000D	543	20	8.9 x 16.3 x 7.6	3.8"A x 15.8"B	.28" DIA	<a href="#">A-14 (p70)</a>
	543	20	8.9 x 16.3 x 7.6	3.8"A x 15.8"B	.28" DIA	<a href="#">A-14 (p70)</a>
	561	23	10.7 x 16.3 x 7.6	3.8"A x 15.8"B	.28" DIA	<a href="#">A-14 (p70)</a>
MAPP1200D	562	23	10.7 x 16.3 x 7.6	3.8"A x 15.8"B	.28" DIA	<a href="#">A-14 (p70)</a>
	562	23	10.7 x 16.3 x 7.6	3.8"A x 15.8"B	.28" DIA	<a href="#">A-14 (p70)</a>
	562	23	10.7 x 16.3 x 7.6	3.8"A x 15.8"B	.28" DIA	<a href="#">A-14 (p70)</a>

## Matrix AP 480 Volts, 60Hz Capacitor and Cap-panel Bolt Hole Mounting Patterns (Continued)

Table 3-10 Continued: Matrix AP 480V Capacitor and Cap-panel Bolt Hole Mounting Patterns

Part Number	Cap-panel P/N	App. Wt. (lbs.)	Overall Size (in.) (H x W x D)	Rear Mount Centerline	Mounting Holes	Ref. Fig.
MAPP1600D	563	23	10.7 x 16.3 x 7.6	3.8"A x 15.8"B	.28" DIA	<a href="#">A-14 (p70)</a>
	563	23	10.7 x 16.3 x 7.6	3.8"A x 15.8"B	.28" DIA	<a href="#">A-14 (p70)</a>
	563	23	10.7 x 16.3 x 7.6	3.8"A x 15.8"B	.28" DIA	<a href="#">A-14 (p70)</a>
	563	23	10.7 x 16.3 x 7.6	3.8"A x 15.8"B	.28" DIA	<a href="#">A-14 (p70)</a>
MAPP2000D	563	23	10.7 x 16.3 x 7.6	3.8"A x 15.8"B	.28" DIA	<a href="#">A-14 (p70)</a>
	563	23	10.7 x 16.3 x 7.6	3.8"A x 15.8"B	.28" DIA	<a href="#">A-14 (p70)</a>
	563	23	10.7 x 16.3 x 7.6	3.8"A x 15.8"B	.28" DIA	<a href="#">A-14 (p70)</a>
	563	23	10.7 x 16.3 x 7.6	3.8"A x 15.8"B	.28" DIA	<a href="#">A-14 (p70)</a>
	563	23	10.7 x 16.3 x 7.6	3.8"A x 15.8"B	.28" DIA	<a href="#">A-14 (p70)</a>
MAPP2300D	562	23	10.7 x 16.3 x 7.6	3.8"A x 15.8"B	.28" DIA	<a href="#">A-14 (p70)</a>
	562	23	10.7 x 16.3 x 7.6	3.8"A x 15.8"B	.28" DIA	<a href="#">A-14 (p70)</a>
	562	23	10.7 x 16.3 x 7.6	3.8"A x 15.8"B	.28" DIA	<a href="#">A-14 (p70)</a>
	562	23	10.7 x 16.3 x 7.6	3.8"A x 15.8"B	.28" DIA	<a href="#">A-14 (p70)</a>
	562	23	10.7 x 16.3 x 7.6	3.8"A x 15.8"B	.28" DIA	<a href="#">A-14 (p70)</a>
	562	23	10.7 x 16.3 x 7.6	3.8"A x 15.8"B	.28" DIA	<a href="#">A-14 (p70)</a>

**Note: Units above 403 amps require multiple parallel cap panels.  
Use the above table and referenced figures to establish suitable Cap-panel mounting.**

## Matrix AP 600 Volts, 60Hz Part Number Selection Tables Open Panel

Table 3-11: Matrix AP 600V Open Panel

Filter Amps Rating	Part Number	App. Wt. (lbs.)	HMR Size (in.) (H x W x D)	HMR Ref. Fig.	Cap-panel P/N	3-Phase Capacitor (in.) (H x D) Capacitor Panel (in.) (H x W x D)	Cap. Ref. Fig.
6	MAPP0006E	17	8.7 x 8.0 x 5.5	<a href="#">A-1 (p57)</a>	CAP-361TP	7.5 x 2.9	<a href="#">A-13 (p69)</a>
8	MAPP0008E	26	9.8 x 9.0 x 4.8	<a href="#">A-1 (p57)</a>	CAP-362TP	7.5 x 2.9	<a href="#">A-13 (p69)</a>
11	MAPP0011E	30	9.8 x 9.0 x 5.3	<a href="#">A-1 (p57)</a>	CAP-363TP	7.5 x 2.9	<a href="#">A-13 (p69)</a>
14	MAPP0014E	47	11.7 x 10.5 x 6.6	<a href="#">A-1 (p57)</a>	CAP-364TP	7.5 x 3.9	<a href="#">A-13 (p69)</a>
21	MAPP0021E	52	11.7 x 10.5 x 7.1	<a href="#">A-1 (p57)</a>	CAP-365TP	7.5 x 3.9	<a href="#">A-13 (p69)</a>
27	MAPP0027E	62	11.7 x 10.5 x 7.6	<a href="#">A-1 (p57)</a>	CAP-366TP	7.5 x 4.6	<a href="#">A-13 (p69)</a>
34	MAPP0034E	74	11.7 x 10.5 x 8.1	<a href="#">A-1 (p57)</a>	CAP-367TP	7.5 x 4.6	<a href="#">A-13 (p69)</a>
44	MAPP0044E	94	14.0 x 12.0 x 9.9	<a href="#">A-3 (p59)</a>	CAP-368TP	9.1 x 4.6	<a href="#">A-13 (p69)</a>
52	MAPP0052E	107	14.0 x 12.0 x 10.3	<a href="#">A-3 (p59)</a>	CAP-369TP	9.1 x 4.6	<a href="#">A-13 (p69)</a>
66	MAPP0066E	135	14.0 x 12.0 x 11.0	<a href="#">A-3 (p59)</a>	CAP-370TP	10.6 x 4.6	<a href="#">A-13 (p69)</a>
83	MAPP0083E	140	14.1 x 12.0 x 11.0	<a href="#">A-3 (p59)</a>	CAP-371TP	10.6 x 4.6	<a href="#">A-13 (p69)</a>
103	MAPP0103E	165	20.0 x 15.3 x 10.7	<a href="#">A-5 (p61)</a>	567	6.9 x 16.3 x 7.6	<a href="#">A-14 (p70)</a>
128	MAPP0128E	223	20.0 x 15.3 x 11.7	<a href="#">A-5 (p61)</a>	568	6.9 x 16.3 x 7.6	<a href="#">A-14 (p70)</a>
165	MAPP0165E	237	20.1 x 15.3 x 11.9	<a href="#">A-5 (p61)</a>	570	6.9 x 16.3 x 7.6	<a href="#">A-14 (p70)</a>
208	MAPP0208E	337	20.1 x 15.3 x 13.4	<a href="#">A-5 (p61)</a>	572	7.9 x 16.3 x 7.6	<a href="#">A-14 (p70)</a>
240	MAPP0240E	433	20.0 x 15.3 x 16.1	<a href="#">A-6 (p62)</a>	574	8.9 x 16.3 x 7.6	<a href="#">A-14 (p70)</a>
320	MAPP0320E	477	23.3 x 15.3 x 15.7	<a href="#">A-6 (p62)</a>	576	10.7 x 16.3 x 7.6	<a href="#">A-14 (p70)</a>
403	MAPP0403E	483	23.3 x 15.3 x 16.1	<a href="#">A-6 (p62)</a>	578	11.5 x 16.3 x 7.6	<a href="#">A-14 (p70)</a>
482	MAPP0482E	736	25.8 x 24.0 x 16.7	<a href="#">A-10 (p66)</a>	574	8.9 x 16.3 x 7.6	<a href="#">A-14 (p70)</a>
					574	8.9 x 16.3 x 7.6	<a href="#">A-14 (p70)</a>
636	MAPP0636E	911	25.9 x 24.0 x 18.2	<a href="#">A-10 (p66)</a>	576	10.7 x 16.3 x 7.6	<a href="#">A-14 (p70)</a>
					576	10.7 x 16.3 x 7.6	<a href="#">A-14 (p70)</a>
786	MAPP0786E	1137	25.0 x 24.0 x 19.5	<a href="#">A-10 (p66)</a>	578	11.5 x 16.3 x 7.6	<a href="#">A-14 (p70)</a>
					578	11.5 x 16.3 x 7.6	<a href="#">A-14 (p70)</a>

## Matrix AP 600 Volts, 60Hz Part Number Selection Tables Enclosed

Table 3-12: Matrix AP 600V Enclosed

Filter Amps Rating	NEMA 1/2	Enclosure	App. Weight (lbs.)	NEMA 3R	Enclosure	App. Weight (lbs.)	Ref. Fig.
6	MAPG0006E	CAB-12AP2	65	MAPW0006E	CAB-12AP3	73	<a href="#">A-15 (p71)</a>
8	MAPG0008E	CAB-12AP2	74	MAPW0008E	CAB-12AP3	82	<a href="#">A-15 (p71)</a>
11	MAPG0011E	CAB-12AP2	79	MAPW0011E	CAB-12AP3	87	<a href="#">A-15 (p71)</a>
14	MAPG0014E	CAB-12AP2	97	MAPW0014E	CAB-12AP3	105	<a href="#">A-15 (p71)</a>
21	MAPG0021E	CAB-12AP2	101	MAPW0021E	CAB-12AP3	109	<a href="#">A-15 (p71)</a>
27	MAPG0027E	CAB-12AP2	112	MAPW0027E	CAB-12AP3	120	<a href="#">A-15 (p71)</a>
34	MAPG0034E	CAB-12AP2	125	MAPW0034E	CAB-12AP3	133	<a href="#">A-15 (p71)</a>
44	MAPG0044E	CAB-17AP2	172	MAPW0044E	CAB-17AP3	179	<a href="#">A-16 (p72)</a>
52	MAPG0052E	CAB-17AP2	185	MAPW0052E	CAB-17AP3	192	<a href="#">A-16 (p72)</a>
66	MAPG0066E	CAB-17AP2	209	MAPW0066E	CAB-17AP3	217	<a href="#">A-16 (p72)</a>
83	MAPG0083E	CAB-17AP2	313	MAPW0083E	CAB-17AP3	338	<a href="#">A-16 (p72)</a>
103	MAPG0103E	CAB-26AP2	333	MAPW0103E	CAB-26AP3	358	<a href="#">A-17 (p73)</a>
128	MAPG0128E	CAB-26AP2	392	MAPW0128E	CAB-26AP3	417	<a href="#">A-17 (p73)</a>
165	MAPG0165E	CAB-26AP2	405	MAPW0165E	CAB-26AP3	430	<a href="#">A-17 (p73)</a>
208	MAPG0208E	CAB-26AP2	489	MAPW0208E	CAB-26AP3	514	<a href="#">A-17 (p73)</a>
240	MAPG0240E	CAB-26APD2	630	MAPW0240E	CAB-26APD3	656	<a href="#">A-18 (p74)</a>
320	MAPG0320E	CAB-26APD2	673	MAPW0320E	CAB-26APD3	700	<a href="#">A-18 (p74)</a>
403	MAPG0403E	CAB-42AP2	702	MAPW0403E	CAB-42AP3	710	<a href="#">A-19 (p75)</a>
482	MAPG0482E	CAB-42AP2	1077	MAPW0482E	CAB-42AP3	1085	<a href="#">A-19 (p75)</a>
636	MAPG0636E	CAB-42AP2	1252	MAPW0636E	CAB-42AP3	1260	<a href="#">A-19 (p75)</a>
786	MAPG0786E	CAB-48AP2	1640	MAPW0786E	CAB-48AP3	1647	<a href="#">A-20 (p76)</a>

## Matrix AP 600V, 60Hz Filter Efficiency + Watt loss

Table 3-13: Watt Loss - Matrix AP 600V, 60Hz

Maximum Output Amps RMS	Efficiency (Typical) (%)	600V Power Dissipation @ Rated Current (Typical) (Watts)	Capacitor Current 600V (Typical) Amps RMS
6	97.6%	150	1.98
8	97.8%	183	2.64
11	98.2%	205	3.7
14	98.3%	250	4.62
21	98.7%	285	6.93
27	98.9%	304	9.24
34	99.0%	366	11.8
44	99.1%	395	14.52
52	99.1%	494	17.16
66	99.0%	655	22.16
83	99.1%	718	29.2
103	99.0%	1085	34.7
128	99.2%	1090	39.8
165	99.3%	1285	53.2
208	99.3%	1431	64.8
240	99.3%	1624	72.7
320	99.4%	2021	94.5
403	99.5%	2208	132.3
482	99.5%	2481	141.8
636	99.6%	2884	195.6
786	99.6%	3368	245.0

**Note:** Use the IEC AC-3 rating for the corresponding filter capacitor current when selecting a contactor.



## Matrix AP 600 Volts, 60Hz Mounting Patterns

Table 3-14: Matrix AP 600V Mounting Patterns

Part Number	App. Wt. (lbs.)	Overall Size (in.) (H x W x D)	Rear Mount Centerline	Base Mount Centerline	Mounting Holes	Ref. Fig.
MAPP0006E	17	8.7 x 8.0 x 5.5	7.0"A x 7.2"B	2.8"C x 7.2"E	.28" DIA	<a href="#">A-1 (p57)</a>
MAPP0008E	26	8.7 x 8.0 x 5.5	8.2"A x 8.2"B	2.8"C x 8.2"E	.28" DIA	<a href="#">A-1 (p57)</a>
MAPP0011E	30	9.9 x 9.0 x 4.8	8.1"A x 8.2"B	3.3"C x 8.2"E	.28" DIA	<a href="#">A-1 (p57)</a>
MAPP0014E	47	9.8 x 9.0 x 5.3	9.9"A x 9.7"B	3.5"C x 9.7"E	.28" DIA	<a href="#">A-1 (p57)</a>
MAPP0021E	52	11.7 x 10.5 x 6.6	9.9"A x 9.7"B	4.0"C x 9.7"E	.28" DIA	<a href="#">A-1 (p57)</a>
MAPP0027E	62	11.7 x 10.5 x 7.0	9.9"A x 9.7"B	4.5"C x 9.7"E	.28" DIA	<a href="#">A-1 (p57)</a>
MAPP0034E	74	11.7 x 10.5 x 7.6	9.9"A x 9.7"B	5.0"C x 9.7"E	.28" DIA	<a href="#">A-1 (p57)</a>
MAPP0044E	94	11.7 x 10.5 x 8.0	12.0"A x 11.0"B	5.9"C x 11.0"E	.28" DIA	<a href="#">A-3 (p59)</a>
MAPP0052E	107	14.0 x 12.0 x 9.0	11.6"A x 11.0"B	6.4"C x 11.0"E	.34" DIA	<a href="#">A-3 (p59)</a>
MAPP0066E	135	14.0 x 12.0 x 9.0	11.8"A x 11.0"B	6.9"C x 11.0"E	.34" DIA	<a href="#">A-3 (p59)</a>
MAPP0083E	140	15.7 x 12.0 x 10.7	11.6"A x 11.0"B	6.9"C x 11.0"E	.34" DIA	<a href="#">A-3 (p59)</a>
MAPP0103E	165	15.7 x 12.0 x 11.1	17.1 x 14.0"B	6.0"C x 14.0"E	.34" DIA	<a href="#">A-5 (p61)</a>
MAPP0128E	223	20.0 x 15.3 x 10.7	17.0"A x 14.0"B	7.0"C x 14.0"E	.41" DIA	<a href="#">A-5 (p61)</a>
MAPP0165E	237	20.0 x 15.3 x 11.8	17.4"A x 14.0"B	7.0"C x 14.0"E	.41" DIA	<a href="#">A-5 (p61)</a>
MAPP0208E	337	20.0 x 15.3 x 11.9	17.2"A x 14.0"B	8.0"C x 14.0"E	.41" DIA	<a href="#">A-5 (p61)</a>
MAPP0240E	433	20.0 x 15.3 x 12.8	17.3"A x 14.0"B	10.0"C x 14.0"E	.41" DIA	<a href="#">A-8 (p64)</a>
MAPP0320E	477	20.0 x 15.3 x 14.8	20.4"A x 14.0"B	10.0"C x 14.0"E	.41" DIA	<a href="#">A-8 (p64)</a>
MAPP0403E	483	23.3 x 15.3 x 13.9	20.9"A x 14.0"B	10.0"C x 14.0"E	.41" DIA	<a href="#">A-8 (p64)</a>
MAPP0482E	736	23.3 x 15.3 x 14.4	N/A	9.2"C x 22.0"E	.41" DIA	<a href="#">A-10 (p66)</a>
MAPP0636E	911	26.0 x 24.0 x 16.5	N/A	10.7"C x 22.0"E	1.0" DIA	<a href="#">A-10 (p66)</a>
MAPP0786E	1137	26.0 x 24.0 x 17.8	N/A	12.2"C x 22.0"E	1.0" DIA	<a href="#">A-10 (p66)</a>

## Matrix AP 600 Volts, 60Hz Capacitor and Cap-panel Bolt Hole Mounting Patterns

Table 3-15: Matrix AP 600V Capacitor and Cap-panel Bolt Hole Mounting Patterns

Part Number	Cap-panel P/N	App. Weight (lbs.)	Overall Size (in.) (H x D x W)	Rear Mount Centerline	Mounting Holes	Ref. Fig.
MAPP0006E	CAP-361TP	1.8	7.5 x 2.9	N/A	M12 STUD	<a href="#">A-13 (p69)</a>
MAPP0008E	CAP-362TP	1.95	7.5 x 2.9	N/A	M12 STUD	<a href="#">A-13 (p69)</a>
MAPP0011E	CAP-363TP	1.95	7.5 x 2.9	N/A	M12 STUD	<a href="#">A-13 (p69)</a>
MAPP0014E	CAP-364TP	3.35	7.5 x 2.9	N/A	M12 STUD	<a href="#">A-13 (p69)</a>
MAPP0021E	CAP-365TP	3.4	7.5 x 3.9	N/A	M12 STUD	<a href="#">A-13 (p69)</a>
MAPP0027E	CAP-366TP	4.6	7.5 x 3.9	N/A	M12 STUD	<a href="#">A-13 (p69)</a>
MAPP0034E	CAP-367TP	4.8	7.5 x 3.9	N/A	M12 STUD	<a href="#">A-13 (p69)</a>
MAPP0044E	CAP-368TP	5.4	7.5 x 4.6	N/A	M12 STUD	<a href="#">A-13 (p69)</a>
MAPP0052E	CAP-369TP	5.5	9.2 x 4.6	N/A	M12 STUD	<a href="#">A-13 (p69)</a>
MAPP0066E	CAP-370TP	6.2	9.2 x 4.6	N/A	M12 STUD	<a href="#">A-13 (p69)</a>
MAPP0083E	CAP-371TP	6.5	10.6 x 4.6	N/A	M12 STUD	<a href="#">A-13 (p69)</a>
MAPP0103E	567	16	6.9 x 16.3 x 7.6	3.8"A x 15.8"B	.28" DIA	<a href="#">A-14 (p70)</a>
MAPP0128E	568	16	6.9 x 16.3 x 7.6	3.8"A x 15.8"B	.28" DIA	<a href="#">A-14 (p70)</a>
MAPP0165E	570	16	6.9 x 16.3 x 7.6	3.8"A x 15.8"B	.28" DIA	<a href="#">A-14 (p70)</a>
MAPP0208E	572	18	7.9 x 16.3 x 7.6	3.8"A x 15.8"B	.28" DIA	<a href="#">A-14 (p70)</a>
MAPP0240E	574	20	7.9 x 16.3 x 7.6	3.8"A x 15.8"B	.28" DIA	<a href="#">A-14 (p70)</a>
MAPP0320E	576	23	8.9 x 16.3 x 7.6	3.8"A x 15.8"B	.28" DIA	<a href="#">A-14 (p70)</a>
MAPP0403E	578	25	10.7 x 16.3 x 7.6	3.8"A x 15.8"B	.28" DIA	<a href="#">A-14 (p70)</a>
MAPP0482E	574	20	7.9 x 16.3 x 7.6	3.8"A x 15.8"B	.28" DIA	<a href="#">A-14 (p70)</a>
	574	20	7.9 x 16.3 x 7.6	3.8"A x 15.8"B	.28" DIA	<a href="#">A-14 (p70)</a>
MAPP0636E	576	23	8.9 x 16.3 x 7.6	3.8"A x 15.8"B	.28" DIA	<a href="#">A-14 (p70)</a>
	576	23	8.9 x 16.3 x 7.6	3.8"A x 15.8"B	.28" DIA	<a href="#">A-14 (p70)</a>
MAPP0786E	578	25	10.7 x 16.3 x 7.6	3.8"A x 15.8"B	.28" DIA	<a href="#">A-14 (p70)</a>
	578	25	10.7 x 16.3 x 7.6	3.8"A x 15.8"B	.28" DIA	<a href="#">A-14 (p70)</a>

**Note:** Units above 403 amps require multiple parallel cap panels.

Use the above table and referenced figures to establish suitable Cap-panel mounting.

## Matrix AP 690 Volts, 50Hz Part Number Selection Tables Open Panel

Table 3-16: Matrix AP 690V Open Panel

Filter Amps Rating	Part Number	App. Wt. (lbs.)	HMR Size (in.) (H x W x D)	HMR Ref. Fig.	Cap-panel P/N	3-Phase Capacitor (in.) (H x D) Capacitor Panel (in.) (H x W x D)	Cap. Ref. Fig.
52	MAPP0052F	182	19.8 x 15.3 x 11.1	<a href="#">A-2 (p58)</a>	622	6.9 x 16.3 x 7.6	<a href="#">A-14 (p70)</a>
66	MAPP0066F	193	19.8 x 15.3 x 11.2	<a href="#">A-2 (p58)</a>	612	7.9 x 16.3 x 7.6	<a href="#">A-14 (p70)</a>
83	MAPP0083F	243	19.8 x 15.3 x 11.6	<a href="#">A-4 (p60)</a>	613	6.9 x 16.3 x 7.6	<a href="#">A-14 (p70)</a>
103	MAPP0103F	262	20.1 x 15.3 x 11.7	<a href="#">A-4 (p60)</a>	615	10.7 x 16.3 x 7.6	<a href="#">A-14 (p70)</a>
128	MAPP0128F	311	19.9 x 15.3 x 12.7	<a href="#">A-5 (p61)</a>	617	8.9 x 16.3 x 7.6	<a href="#">A-14 (p70)</a>
165	MAPP0165F	393	19.9 x 15.3 x 14.8	<a href="#">A-5 (p61)</a>	619	10.7 x 16.3 x 7.6	<a href="#">A-14 (p70)</a>
208	MAPP0208F	492	23.1 x 15.3 x 13.7	<a href="#">A-6 (p62)</a>	614	7.9 x 16.3 x 7.6	<a href="#">A-14 (p70)</a>
					616	7.9 x 16.3 x 7.6	<a href="#">A-14 (p70)</a>
240	MAPP0240F	551	23.2 x 15.3 x 14.9	<a href="#">A-6 (p62)</a>	616	7.9 x 16.3 x 7.6	<a href="#">A-14 (p70)</a>
					617	8.9 x 16.3 x 7.6	<a href="#">A-14 (p70)</a>
320	MAPP0320F	912	25.9 x 24.0 x 16.2	<a href="#">A-9 (p65)</a>	618	10.7 x 16.3 x 7.6	<a href="#">A-14 (p70)</a>
					618	10.7 x 16.3 x 7.6	<a href="#">A-14 (p70)</a>
403	MAPP0403F	982	25.8 x 24.0 x 17.3	<a href="#">A-9 (p65)</a>	614	7.9 x 16.3 x 7.6	<a href="#">A-14 (p70)</a>
					618	10.7 x 16.3 x 7.6	<a href="#">A-14 (p70)</a>
					618	10.7 x 16.3 x 7.6	<a href="#">A-14 (p70)</a>
482	MAPP0482F	1167	25.9 x 24.0 x 19.0	<a href="#">A-9 (p65)</a>	618	10.7 x 16.3 x 7.6	<a href="#">A-14 (p70)</a>
					618	10.7 x 16.3 x 7.6	<a href="#">A-14 (p70)</a>
					618	10.7 x 16.3 x 7.6	<a href="#">A-14 (p70)</a>
636	MAPP0636F	1404	25.9 x 24.0 x 21.3	<a href="#">A-10 (p66)</a>	620	11.5 x 16.3 x 7.6	<a href="#">A-14 (p70)</a>
					621	11.5 x 16.3 x 7.6	<a href="#">A-14 (p70)</a>
					621	11.5 x 16.3 x 7.6	<a href="#">A-14 (p70)</a>

## Matrix AP 690V, 50Hz Filter Efficiency + Watt loss

Table 3-17: Watt Loss - Matrix AP 690V, 50Hz

Maximum Output Amps RMS	Efficiency (Typical) (%)	690V Power Dissipation @ Rated Current (Typical) (Watts)	Capacitor Current 690V (Typical) Amps RMS
52	98.9	681	17.16
66	98.9	844	21.78
83	99.1	850	27.39
103	99.1	1051	33.99
128	99.3	1106	42.24
165	99.4	1257	54.45
208	99.4	1400	68.64
240	99.4	1721	79.2
320	99.5	2031	105.6
403	99.4	2780	132.99
482	99.5	2883	159.06
636	99.6	3140	209.88

**Note:** Use the IEC AC-3 rating for the corresponding filter capacitor current when selecting a contactor.

## Matrix AP 690 Volts, 50Hz Mounting Patterns

**Table 3-18: Matrix AP 690V Mounting Patterns**

Part Number	App. Wt. (lbs.)	Overall Size (in.) (H x W x D)	Rear Mount Centerline	Base Mount Centerline	Mounting Holes	Ref. Fig.
MAPP0052F	182	20.0 x 15.3 x 11.1	16.9"A x 14.0"B	6.0"C x 14.0"E	.41" DIA	<a href="#">A-2 (p58)</a>
MAPP0066F	193	20.0 x 15.3 x 11.2	17.0"A x 14.0"B	6.0"C x 14.0"E	.41" DIA	<a href="#">A-2 (p58)</a>
MAPP0083F	243	20.0 x 15.3 x 11.6	16.9"A x 14.0"B	7.0"C x 14.0"E	.41" DIA	<a href="#">A-4 (p60)</a>
MAPP0103F	262	20.1 x 15.3 x 11.7	17.2"A x 14.0"B	7.0"C x 14.0"E	.41" DIA	<a href="#">A-4 (p60)</a>
MAPP0128F	311	20.0 x 15.3 x 12.7	17.0"A x 14.0"B	8.0"C x 14.0"E	.41" DIA	<a href="#">A-5 (p61)</a>
MAPP0165F	393	20.0 x 15.3 x 14.9	17.0"A x 14.0"B	10.0"C x 14.0"E	.41" DIA	<a href="#">A-5 (p61)</a>
MAPP0208F	492	23.1 x 15.3 x 13.7	20.2"A x 14.0"B	9.2"C x 14.0"E	.41" DIA	<a href="#">A-6 (p62)</a>
MAPP0240F	551	23.2 x 15.3 x 14.9	20.3"A x 14.0"B	10.1"C x 14.0"E	.41" DIA	<a href="#">A-6 (p62)</a>
MAPP0320F	912	26.0 x 24.0 x 16.2	N/A	9.2"C x 22.0"E	1.0" DIA	<a href="#">A-9 (p65)</a>
MAPP0403F	982	26.0 x 24.0 x 17.3	N/A	10.7"C x 22.0"E	1.0" DIA	<a href="#">A-9 (p65)</a>
MAPP0482F	1167	26.0 x 24.0 x 19.0	N/A	12.2"C x 22.0"E	1.0" DIA	<a href="#">A-9 (p65)</a>
MAPP0636F	1404	26.0 x 24.0 x 21.3	N/A	13.7"C x 22.0"E	1.0" DIA	<a href="#">A-10 (p66)</a>

## Matrix AP 690 Volts, 50Hz Capacitor and Cap-panel Bolt Hole Mounting Patterns

Table 3-19: Matrix AP 690V Capacitor and Cap-panel Bolt Hole Mounting Patterns

Part Number	Cap-panel P/N	App. Wt. (lbs.)	Cap-panel Size (in.) (H x D x W)	Rear Mount Centerline	Mounting Holes	Ref. Fig.
MAPP0052F	622	14	6.9 x 16.3 x 7.6	3.8"A x 15.8"B	.28" DIA	<a href="#">A-14 (p70)</a>
MAPP0066F	612	16	7.9 x 16.3 x 7.6	3.8"A x 15.8"B	.28" DIA	<a href="#">A-14 (p70)</a>
MAPP0083F	613	14	6.9 x 16.3 x 7.6	3.8"A x 15.8"B	.28" DIA	<a href="#">A-14 (p70)</a>
MAPP0103F	615	2	10.7 x 16.3 x 7.6	3.8"A x 15.8"B	.28" DIA	<a href="#">A-14 (p70)</a>
MAPP0128F	617	18	8.9 x 16.3 x 7.6	3.8"A x 15.8"B	.28" DIA	<a href="#">A-14 (p70)</a>
MAPP0165F	619	21	10.7 x 16.3 x 7.6	3.8"A x 15.8"B	.28" DIA	<a href="#">A-14 (p70)</a>
MAPP0208F	614	16	7.9 x 16.3 x 7.6	3.8"A x 15.8"B	.28" DIA	<a href="#">A-14 (p70)</a>
	616	16	7.9 x 16.3 x 7.6	3.8"A x 15.8"B	.28" DIA	<a href="#">A-14 (p70)</a>
MAPP0240F	616	16	7.9 x 16.3 x 7.6	3.8"A x 15.8"B	.28" DIA	<a href="#">A-14 (p70)</a>
	617	18	8.9 x 16.3 x 7.6	3.8"A x 15.8"B	.28" DIA	<a href="#">A-14 (p70)</a>
MAPP0320F	618	21	10.7 x 16.3 x 7.6	3.8"A x 15.8"B	.28" DIA	<a href="#">A-14 (p70)</a>
	618	21	10.7 x 16.3 x 7.6	3.8"A x 15.8"B	.28" DIA	<a href="#">A-14 (p70)</a>
MAPP0403F	614	16	7.9 x 16.3 x 7.6	3.8"A x 15.8"B	.28" DIA	<a href="#">A-14 (p70)</a>
	618	21	10.7 x 16.3 x 7.6	3.8"A x 15.8"B	.28" DIA	<a href="#">A-14 (p70)</a>
	618	21	10.7 x 16.3 x 7.6	3.8"A x 15.8"B	.28" DIA	<a href="#">A-14 (p70)</a>
MAPP0482F	618	21	10.7 x 16.3 x 7.6	3.8"A x 15.8"B	.28" DIA	<a href="#">A-14 (p70)</a>
	618	21	10.7 x 16.3 x 7.6	3.8"A x 15.8"B	.28" DIA	<a href="#">A-14 (p70)</a>
	618	21	10.7 x 16.3 x 7.6	3.8"A x 15.8"B	.28" DIA	<a href="#">A-14 (p70)</a>
MAPP0636F	620	23	11.5 x 16.3 x 7.6	3.8"A x 15.8"B	.28" DIA	<a href="#">A-14 (p70)</a>
	621	23	11.5 x 16.3 x 7.6	3.8"A x 15.8"B	.28" DIA	<a href="#">A-14 (p70)</a>
	621	23	11.5 x 16.3 x 7.6	3.8"A x 15.8"B	.28" DIA	<a href="#">A-14 (p70)</a>

**Note: Units above 165 amps require multiple parallel cap panels.**

**Use the above table and referenced figures to establish suitable Cap-panel mounting.**

## 4. PRODUCT SPECIFICATIONS

### Performance Specifications

**Table 4-1: Performance Specifications**

<b>Service Conditions</b>	Load: 6-pulse variable torque rectifier only
Input Voltage(s)	400V Version (PN#'s MAPxxxxxC) - 380-415 VAC +/- 10%. 50 + 0.75 Hz. 3 phase 480V Version (PN#'s MAPxxxxxD) - 480 VAC +/- 10%, 60 + 0.75 Hz. 3 phase 600V Version (PN#'s MAPxxxxxE) - 600 VAC +/- 10%. 60 + 0.75 Hz. 3 phase 690V Version (PN#'s MAPxxxxxF) - 690 VAC +/- 10%. 50 + 0.75 Hz. 3 phase
Input voltage line unbalance	1% maximum to ensure performance guaranty
Maximum source impedance	<b>6.00% to ensure performance guaranty. Please contact MTE for sizing with Gensets.</b>
Minimum source impedance	1.5%
Service Factor	1.00
Overload	150% for 1 minute duration with 10% output voltage reduction of nominal of voltage
Ambient Temperature (Operating)	Refer to figure 5 for temperature de-rating
Enclosed Filters	320A and above: -40 to +45 degrees C Below 320A: -40 to +40 degrees C
Open Panel Filters	-40 to +50 degrees C
Storage Temperature	-40 to +90 degrees C
Altitude	0 to 3300 Feet above sea level. Refer to figure 4 for altitude de-rating
Relative Humidity	0 to 95% non-condensing
Over Voltage	Category II
Insertion Load	+5% no load -5% full load

**Generator sizing note:** Generator sizing is best completed by sizing programs or help from a generator manufacturing representative. Identify every load type and size that will be powered from the generator.

If non-linear loads are present the generator may need to be oversized.

Generator rated KVA minimum load  $\geq$  Matrix rated current  $\times \sqrt{3}$  generator voltage

FLA load current  $\leq$  Matrix filter rated current

#### **Notes (SCCR):**

***The Short Circuit Current Rating (SCCR) is not required under Exception No.1 of UL508A SB4.2.1 effective 4/25/06. This exception also applies to all the Contactor Options (002, 009, 012, and similar), where the Contactors are separated from the Main Power path by exempt components (such as Reactors) of sufficient Impedance, which is assured in case of the Reactors that are integral components of our Filter.***

## Enclosures

MTE enclosures are designed to provide a degree of protection for electrical components and prevent incidental personnel contact with the enclosed equipment. Depending on the enclosure selected, these enclosures meet the requirements of NEMA 1, 2 or 3R.

An approximate cross reference guide between NEMA, UL, CSA and IEC enclosure follows.

### Type 1 NEMA / IEC IP20 Enclosure:

Are designed for indoor use and will provide protection against contact with the enclosed equipment.

### Type 2 NEMA / IEC IP20 Enclosure:

Are designed for indoor use and will provide protection against contact with the enclosed equipment and provide a degree of protection against limited amounts of falling water and dirt.

### Type 3R NEMA / IEC IP23 Enclosure:

Are designed for outdoor use primarily to provide protection against contact with the enclosed equipment and provide a degree of protection against falling rain sleet and external ice formation.

## Agency Approvals

UL and cUL listed to UL508 Type Mx and CSA-C22.2 No 14-95  
File E180243

## Warranty

Three years from the date of shipment. See [www.mtecorp.com](http://www.mtecorp.com) for details.

## Over Temperature Switch

**Table 4-2: Over Temperature Switch**

<i>NC Switch</i> opens at 180 Deg. +/- 5 Deg. C		
Current Amps	Voltage	Contact Load
6	120 AC	Resistive Loads
3	120 AC	Inductive Loads
3	240 AC	Resistive Loads
2.5	240 AC	Inductive Loads
8	12 VDC	Resistive Loads
4	24 VDC	Resistive Loads

MTE highly recommends the use of the over temperature switch to prevent damage to the filter in rare instances of overheating from abnormal operating conditions.



## 5. TYPICAL PERFORMANCE DATA

### Load Effect on THID

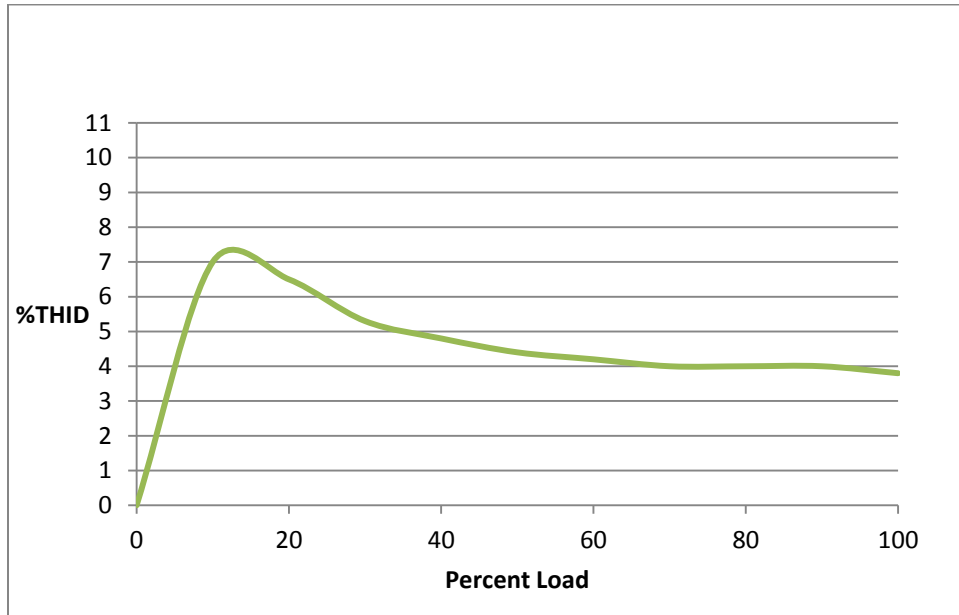

Figure 5-1: Load Effect on THID

### Typical Harmonic Spectrum

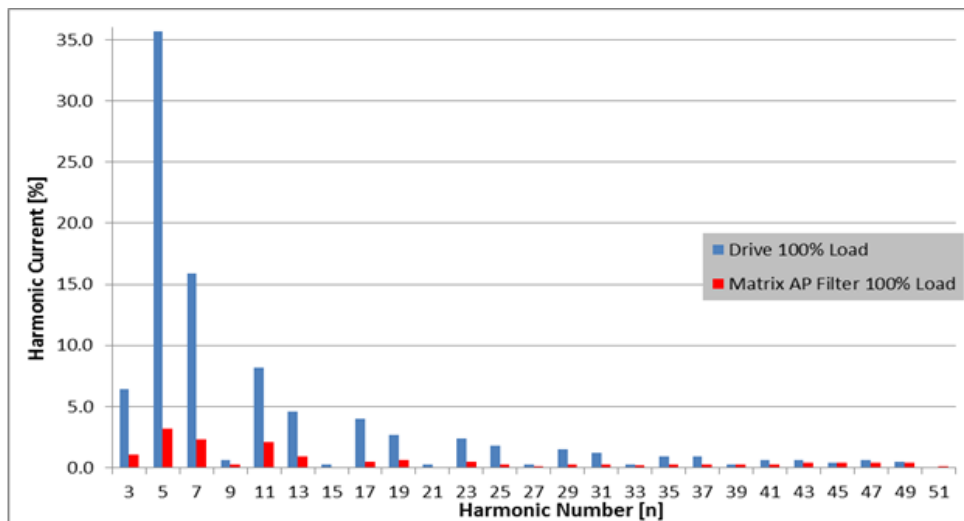

Figure 5-2: Typical Harmonic Spectrum with and without Matrix AP

### Power Factor

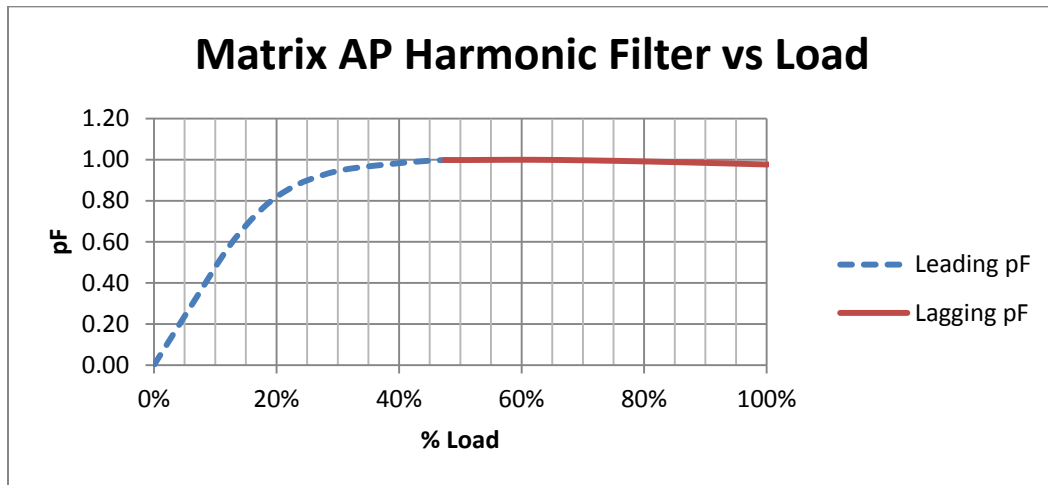

Figure 5-3: Power Factor

### Performance with Unbalanced Line Voltage (Typical)

Table 5-1: Performance with Unbalanced Line Voltage (Typical)

All Components at Nominal Values and Worse Case Service Conditions	
100% Load	
Nominal THID	4.2%
1% Unbalance	4.4%
2% Unbalance	4.8%
3% Unbalance	5.4%
30% Load	
Nominal THID	7.0%
1% Unbalance	7.3%
2% Unbalance	7.9%
3% Unbalance	8.8%

### Altitude Derating

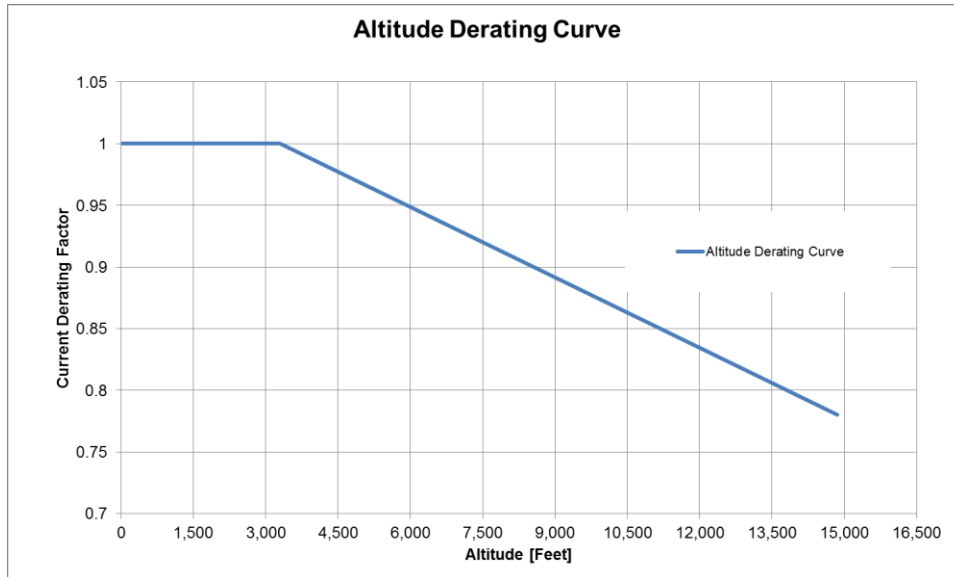

Figure 5-3: Altitude Derating Curve

### Temperature Derating

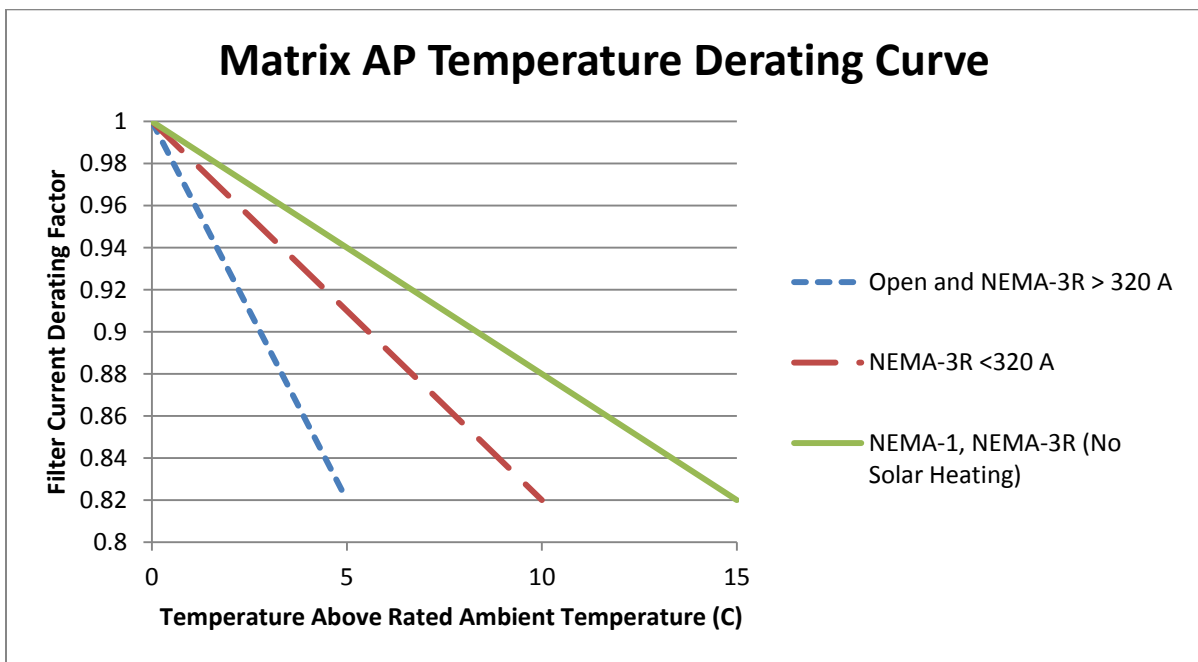

Figure 5-4: Temperature Derating

**Note:** Do not extend derating beyond published data. See or click [Specifications](#) for temperature ratings

### Voltage Distortion Derating Curve

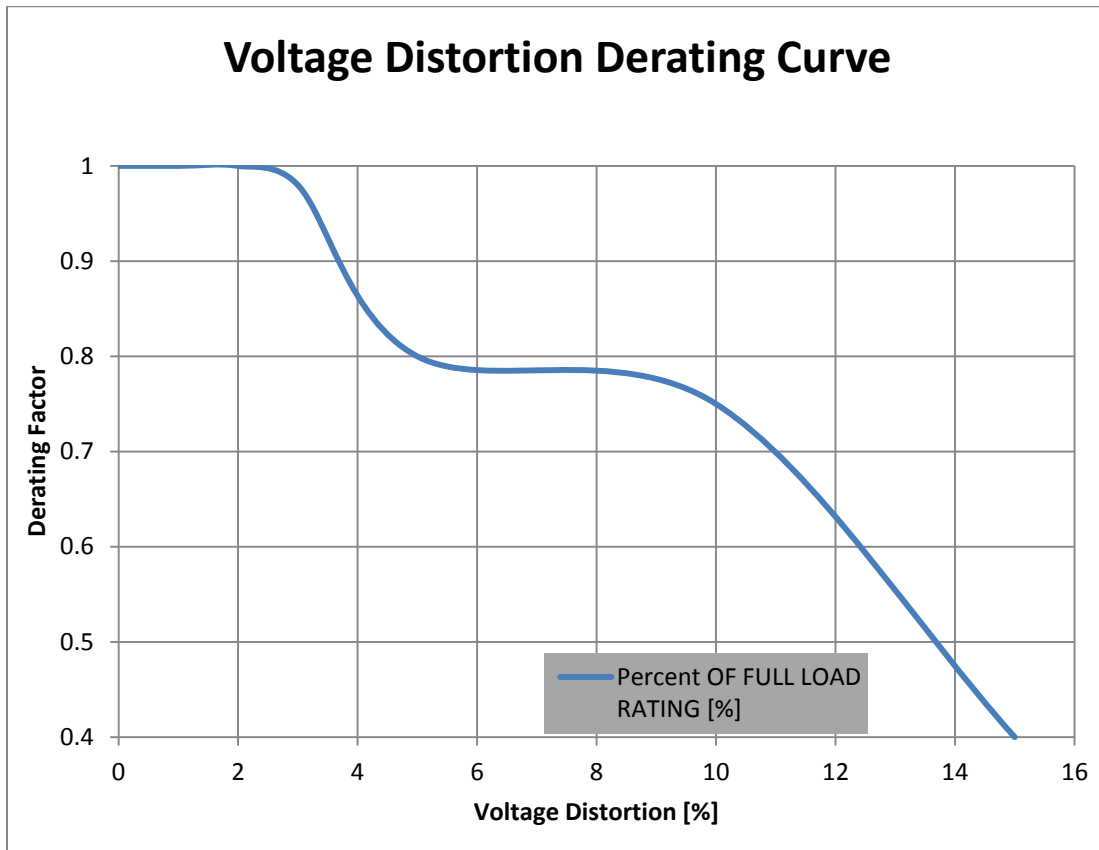





Figure 5-5: Voltage Distortion Derating Curve

This plot assists in proper de-rating of a Matrix AP Harmonic Filter in environments with a given voltage distortion. Example: In a system with 10% voltage distortion, a Matrix filter will need to be oversized by 25% to obtain the same performance as an appropriate filter in a 0% distortion environment.

## 6. HOW TO INSTALL

### Installation Checklist

 <b>WARNING</b>	<p>Prior to installation, please refer to all general warnings on page 5. Failure to practice this can result in body injury!</p>
 <b>WARNING</b>	<p>Input and output wiring to the filter should be performed by authorized personnel in accordance with NEC and all local electrical codes and regulations.</p>
 <b>WARNING</b>	<p>The filter is designed for use with copper conductors with a minimum temperature rating of 75 degrees C.</p>
 <b>WARNING</b>	<p><b>Do not install capacitor assembly above/near the Harmonic Mitigating Reactor. Premature or catastrophic failure may occur.</b></p>

Matrix Filters are supplied in the following mechanical configurations:

- Open Panel Mount
- Floor mounted general purpose NEMA 2, & 3R cabinets

Select a well-ventilated area suitable for the NEMA enclosure type number. Do not install in or near a corrosive environment. Avoid locations where the filter would be subjected to excessive vibrations.

Panel mounted filters are designed for mounting within the customer's enclosure. Panel mount units consist of a Harmonic Mitigating Reactor (HMR) and one or more capacitor panel modules referred to as cap-panels on drawings and diagrams.

The capacitor panel must be located in the lowest temperature regions of the enclosure – generally toward the bottom and away from high temperature components.



Figure A- 1 (p58) to Figure A- 14 (p71) contain outline drawings for the various ratings and show mounting orientation with bolt patterns.

Include the power dissipation of the filter along with all the other components located in the enclosure to determine the internal temperature rise and cooling requirements of the enclosure.

General purpose NEMA 2, and NEMA 3R enclosed filters are designed for floor mounting in an environment suitable for the enclosure type. Do not install in or near a corrosive environment. Avoid locations where the filter would be subjected to excessive vibrations. Allow a minimum side and back clearance of eight (8) inches and front clearance of thirty-six (36) inches for proper heat dissipation and access. For lower ambient temperatures and increased air flow clearance distances can be reduced.

Refer to Article 430 Table 430.91 of the National Electrical code for the selection of the appropriate enclosure Type Number for your application.

## Grounding

 <b>WARNING</b>	The filter must always be grounded with a grounding conductor connected to ground terminals.
 <b>WARNING</b>	For open panel units, ensure a 2" x 2" area is cleaned of paint and varnish on lower mounting bracket for ground connection.
 <b>WARNING</b>	<b>On NEMA 3R enclosures, CAB-26AP and larger, no live parts shall be mounted below 8 inches from the bottom of the enclosure</b>

For cable shield grounding follow the drive manufactures recommendations.

## Over Temperature Interlock

An over temperature interlock circuit should be used in conjunction with thermal switch to turn off the drive to prevent filter damage due to abnormal operating conditions. The temperature switch is normally closed and will open when an internal reactor temperature of 180°C is reached. See Table 4-2 (p31) for contact rating information and the drive user manual for interconnection information.

## Location & Spacing

Open panel filters are designed for mounting in the customer's enclosure. Include the power dissipation of the filter along with all the other components located in the panel to determine the internal temperature rise and cooling requirements of the enclosure. A general guideline is to allow a side clearance of four (4) inches and a vertical clearance of six (6) inches for proper heat dissipation and access within the enclosure. Clearances may be less if proper ventilation exists. Filter components must operate within temperatures specified in this manual or filter operating life will be compromised. Also be aware of minimum electrical clearances as defined by the appropriate system safety standard(s). Open panel Matrix AP Filters generate heat and should be positioned away from heat sensitive components. Ensure that proper panel orientation is maintained. Keep the capacitors away from reactor heat flow. Avoid locations where the filter would be subjected to excessive vibrations. Locate the filter as close to the inverter as possible.



General purpose NEMA 1, 2 and 3R enclosed filters are designed for floor mounting in an environment suitable for the enclosure type. Do not install in or near a corrosive environment. Avoid locations where the filter would be subjected to excessive vibrations. Allow a minimum side and back clearance of eight (8) inches for proper ventilation. Also consider spacing required for accessibility. Locate the filter as close to the inverter as possible.

## Mechanical Mounting

Please refer to Part Number Selection Tables for mounting locations.

- **Open Panel**
  - Table 3-1: Matrix AP 400V Open Panel (p9)
  - Table 3-6: Matrix AP 480V Open Panel (p14)
  - Table 3-11: Matrix AP 600V Open Panel (p21)
  - Table 3-16: Matrix AP 690V Open Panel (p26)
- **Enclosed**
  - Table 3-2: Matrix AP 400V Enclosed (p10)
  - Table 3-7: Matrix AP 480V Enclosed (p16)
  - Table 3-12: Matrix AP 600V Enclosed (p22)

## Power Wiring Connection

 <b>WARNING</b>	Input and output power wiring to the filter should be performed by authorized personnel in accordance with the NEC and all local electrical codes and regulations. Cable lugs and mounting hardware are provided by the customer.
 <b>WARNING</b>	Any extremely low or high resistance readings indicate a mis-wire and may result in damage to filter components if not corrected.
 <b>WARNING</b>	On NEMA 3R enclosures, CAB-26AP and larger, no live parts shall be mounted below 8 inches from the bottom of the enclosure.

Verify that the power source to which the filter is to be connected is in agreement with the nameplate data on the filter. A fused disconnect switch or circuit breaker should be installed between the filter and its source of power in accordance with the requirements of the NEC and all local electrical codes and regulations. Refer to the drive user manual for selection of the correct fuse rating and class.

For panel mounted filter applications, interconnection between the filter, its power source, the cap-panels, and the drive is shown in Figure 6-2 (p41). Wire gauge range and terminal torque requirements as well as selecting conductors that interconnect the HMR and capacitor assemblies are shown in Table 6-2 (p49) for 400V - 600V, Table 6-3 (p51) for 690V. Filters that use multiple cap-panels share total cap current shown on Table 3-3 (p11) for 400V, Table 3-8 (p17) for 480V, Table 3-13 (p23) for 600V, and Table 3-17 (p27) for 690V.

Refer to the drive user manual for instructions on interconnecting the drive and motor and the correct start-up procedures for the drive.

The filter is designed for use with copper conductors with a minimum temperature rating of 75 degrees C.

For filters supplied in general purpose NEMA 2 & 3R cabinets, interconnection between the filter, its power source, and the drive is shown in Figure 6-3 (p42).

Refer to Figure A- 1 (p58) to Figure A- 11 (p68) for the location of input, output, ground, and over temperature switch terminals. Refer to the drive user manual for instructions on interconnecting the drive and motor and the correct start-up procedures for the drive.

## **Wiring Checks**

Using Figure 6-1 (p40), visually check the wired components to confirm, verify, and correct wiring. Then, with a multi meter check phase to phase isolation using the 100 K ohm range. The multi meter will read the parallel equivalent of the bleeder resistors after the capacitors initially charge. All phase to phase resistance values should be the same.

### **Check for the Following Faults:**

- Capacitor shorted
- Capacitor bus not connected
- Capacitor bus to chassis short
- Paralleling wiring errors

## **Grounding and Ground Fault Protection**

The filter must always be grounded with a grounding conductor connected to all ground terminals.

Due to high leakage currents associated with variable frequency drives, ground fault protective devices do not necessarily operate correctly when placed ahead of a Matrix Filter feeding a drive. When using this type of device, its function should be tested in the actual installation.



### Basic Schematic Diagram

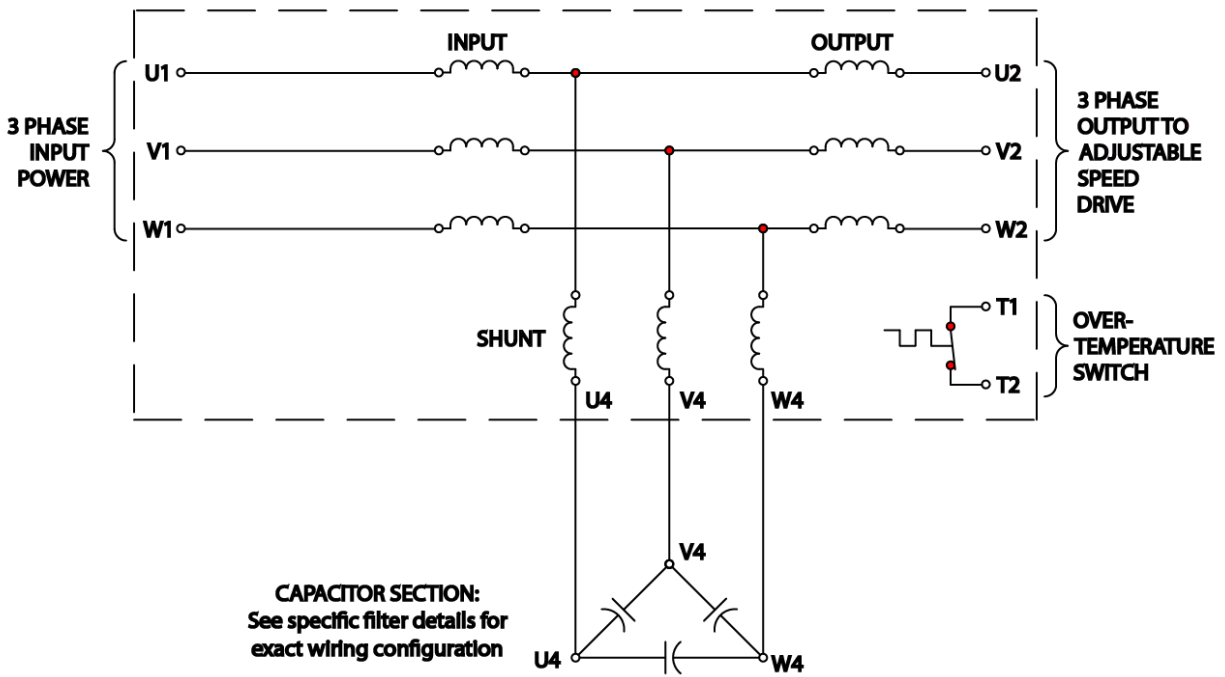

Figure 6-1: Basic Schematic Diagram

*Note: Drawing depicts delta configuration for capacitors, 690V filters are connected in a WYE configuration.*

## Open Panel Unit Interconnection Diagram

### MATRIX-AP OPEN PANEL UNIT INTERCONNECTION DIAGRAM

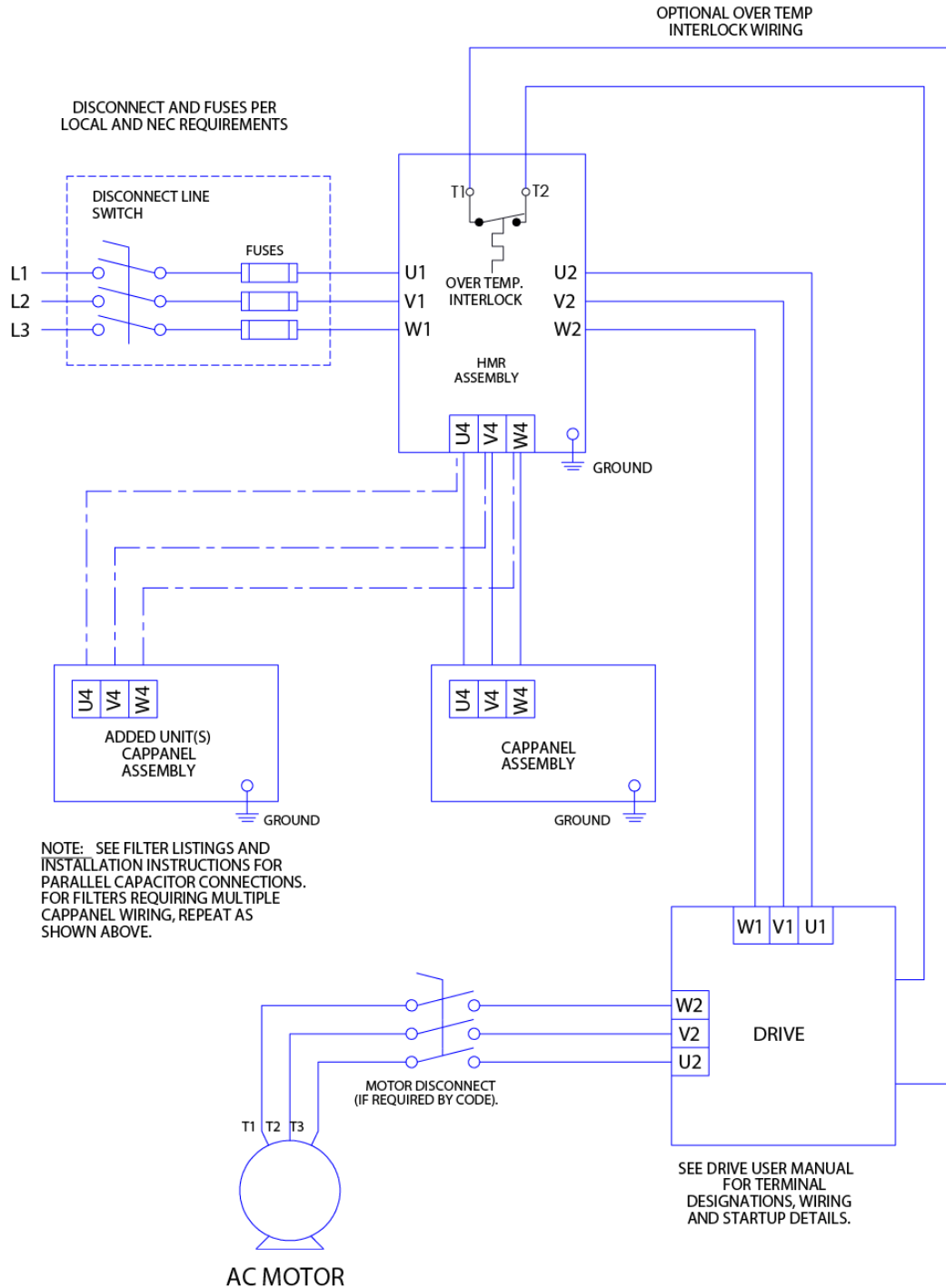

Figure 6-2: Open Panel Interconnection

## Enclosed Unit Interconnection Diagram

### MATRIX-AP ENCLOSED UNIT INTERCONNECTION DIAGRAM

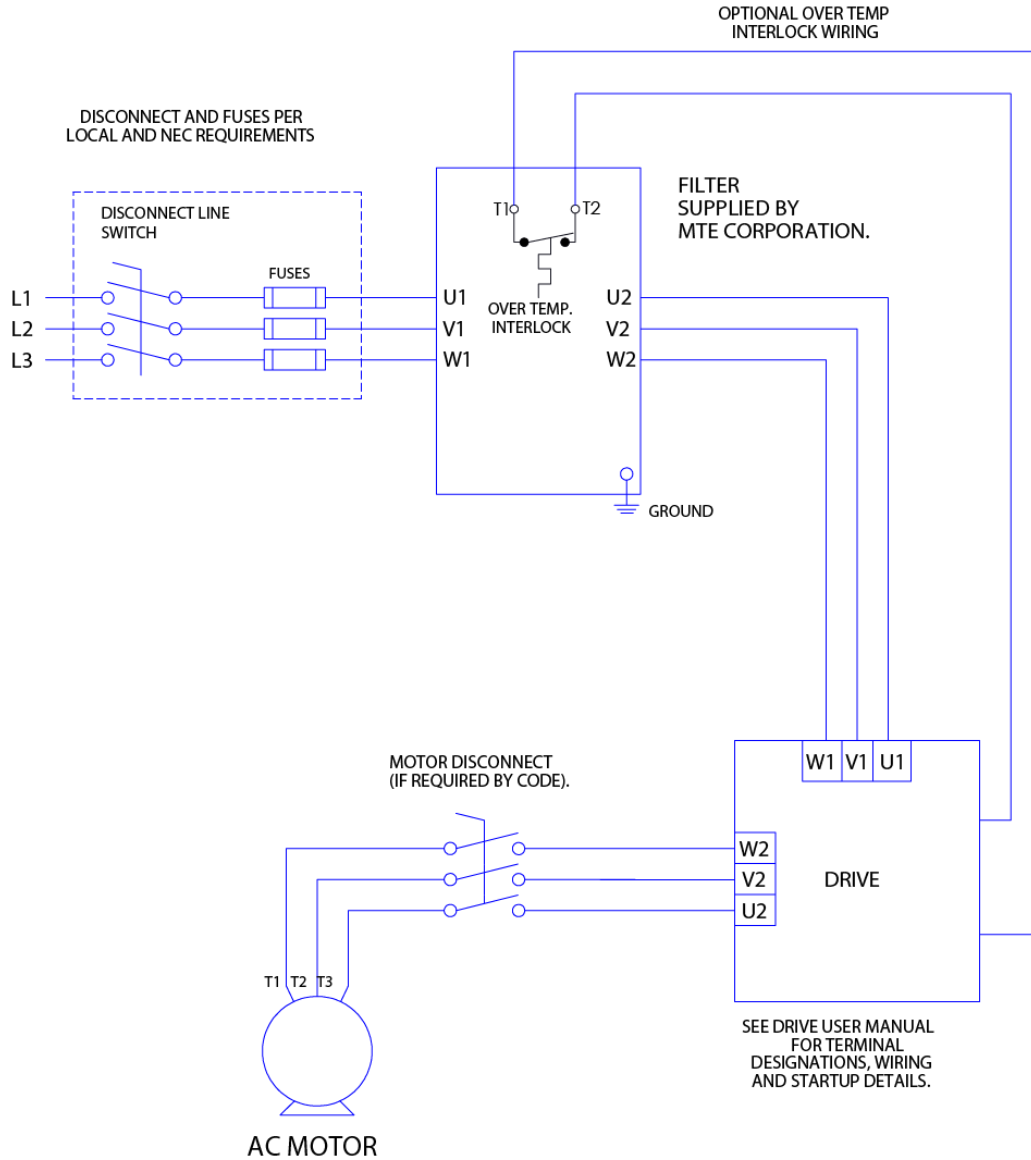

Figure 6-3: Enclosed Interconnection

## Contactor Options

### Option – 002

#### Capacitor Contactor

This option provides a contactor to disconnect the filter capacitor bank when the drive is not running. The contactor is supplied with NO/NC auxiliary contacts. The contactor coil and auxiliary contacts are wired to a customer terminal block. See page 53 for contactor coil switching characteristics. This option is provided pre-wired complete for enclosed filters and as loose parts for open panel filters.

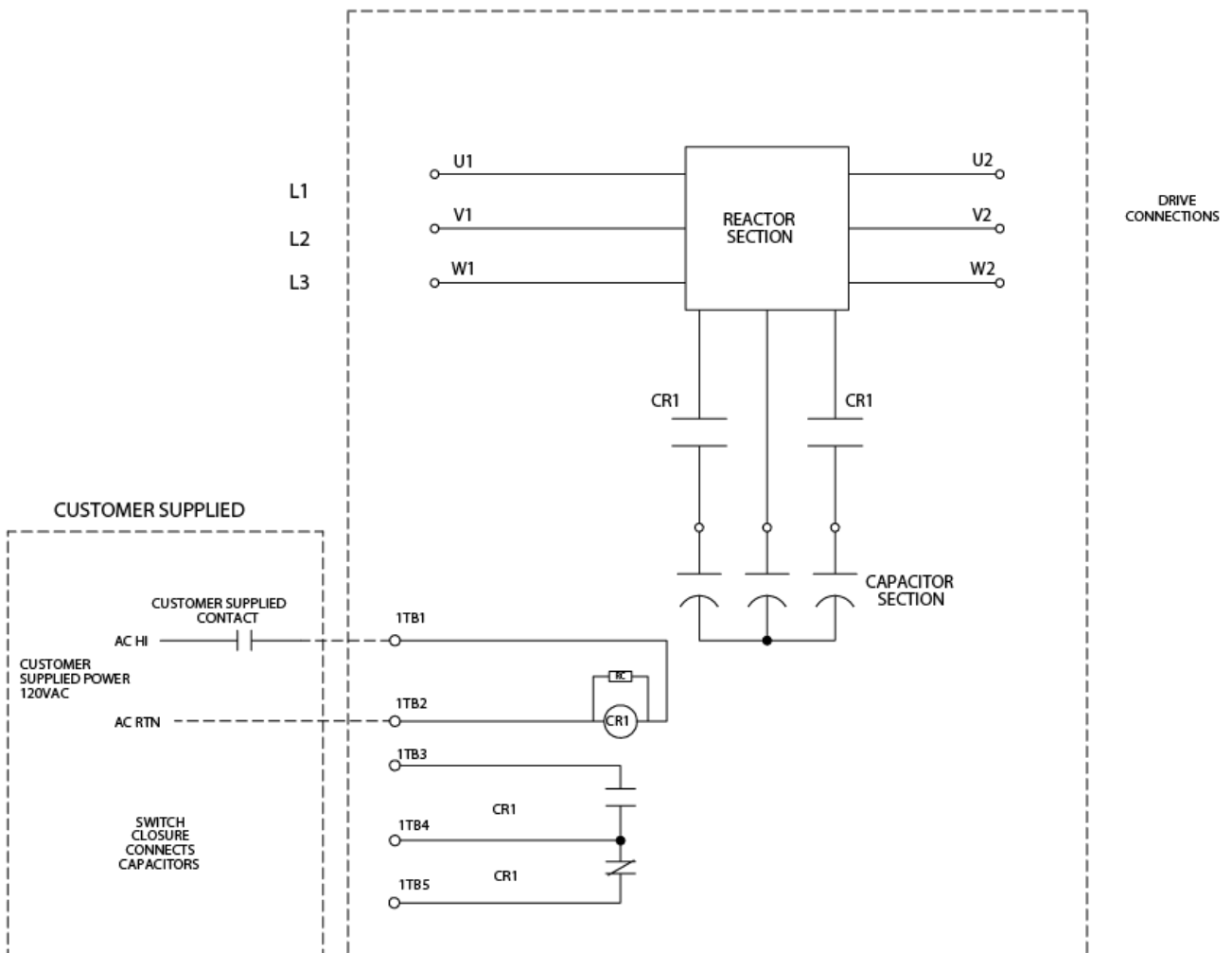

Figure 6-4: Contactor Options – 002

The above contactor option diagram is provided to help understand the circuit function and does not reflect actual circuit wiring.

## Contactor Options

### Option – 009

Capacitor Contactor with adjustable pick up and drop out

This option provides a contactor to disconnect the filter capacitor bank based on the motor load current. Two current operated switches provide independent adjustment of the pick-up and drop out current levels. The switches are preset at the factory for pick up at 35% and drop out at 20% of the filter output current rating. The switches are each field adjustable over a 0 – 100% current range. This option is only available for enclosed filters.

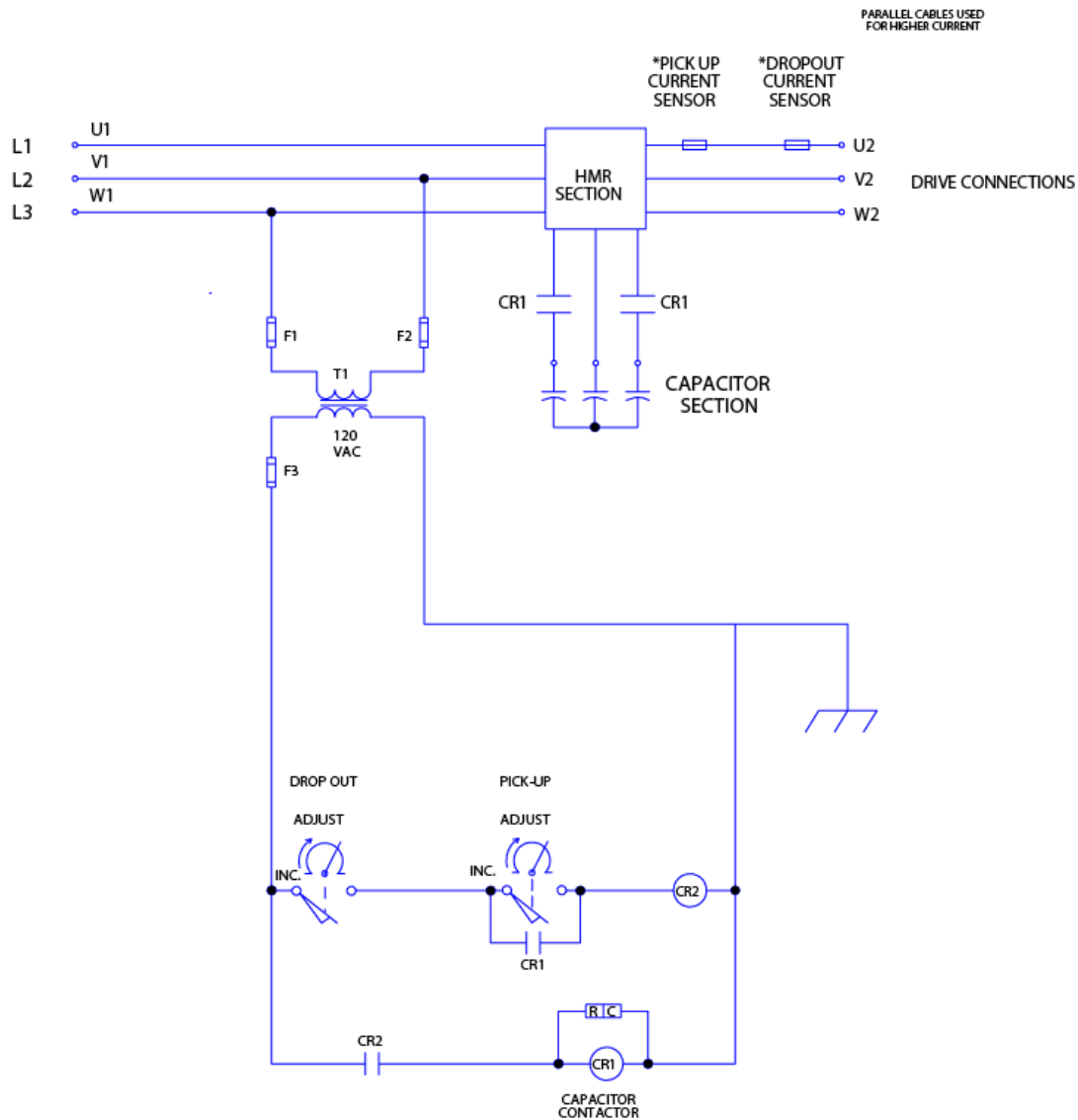

Figure 6-5: Contactor Option – 009

The above contactor option diagram is provided to help understand the circuit function and does not reflect actual circuit wiring.

### Contactor Options

#### Option – 012

Capacitor contactor with control transformer

This option provides a control transformer to power the capacitor contactor. The contactor is provided with NO/NC auxiliary contacts. For filter ratings 165 amps and above a pilot relay is also provided to limit inrush current below 0.60 amps. Connections are wired to a customer terminal block. This option is only available for enclosed filters.

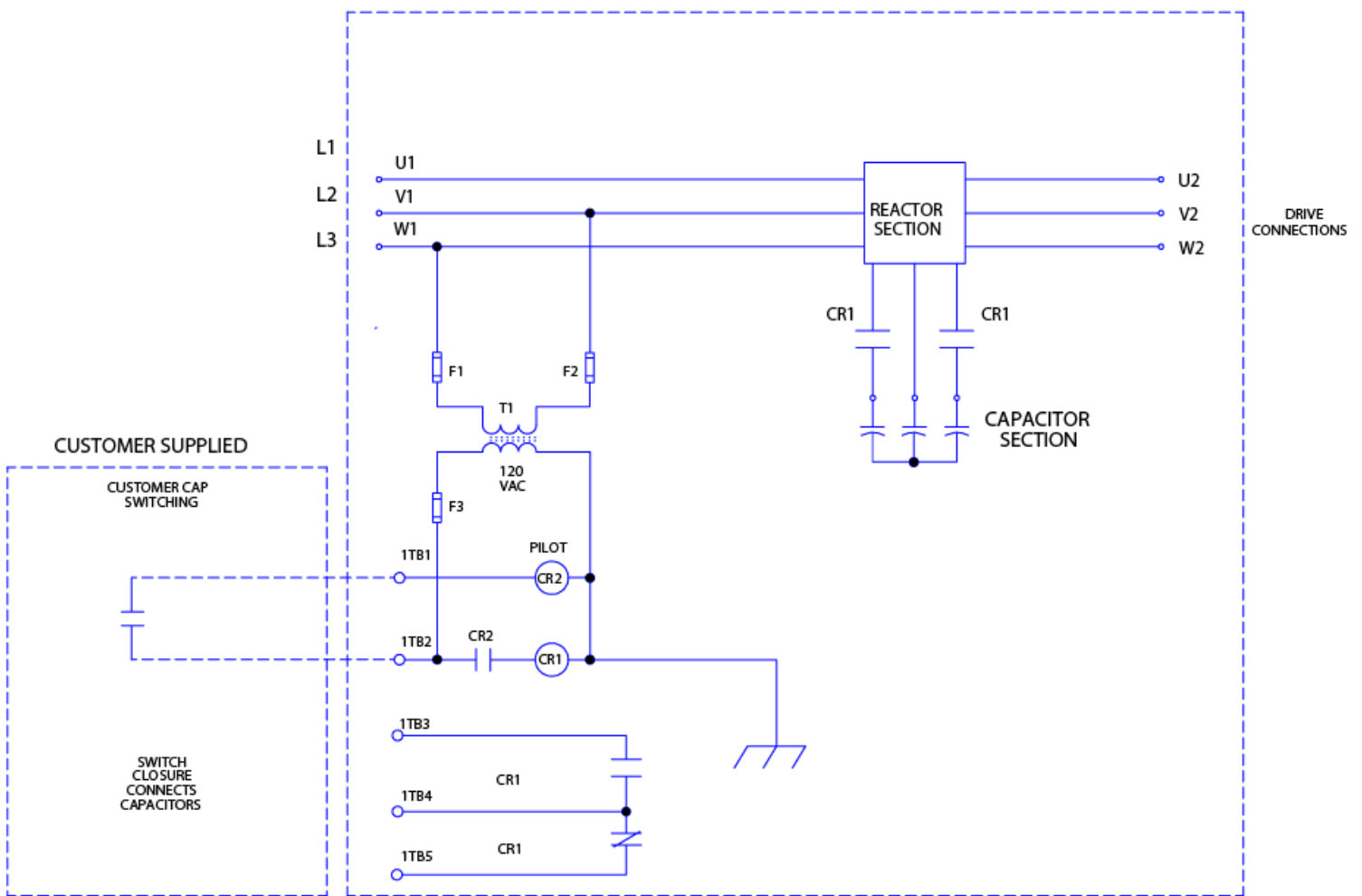

Figure 6-6: Contact Option – 012

The above contactor option diagram is provided to help understand the circuit function and does not reflect actual circuit wiring.

## Contactor Options

### Option – 013

Filter bypass and capacitor contactor with control transformer

This option provides a 120 VAC control transformer to power the capacitor and bypass contactors. Contactors are provided with NO/NC auxiliary contacts. For filter ratings 44 amps and above pilot relays are also provided to limit inrush currents below 0.60 amps. A jumper selection provides single contact switching for normal bypass control with capacitor removal. Connections are wired to a customer terminal block. To incorporate this option for a selected filter current rating use the part numbers shown below and select the option list price from the table below. This option is only available for enclosed filters.

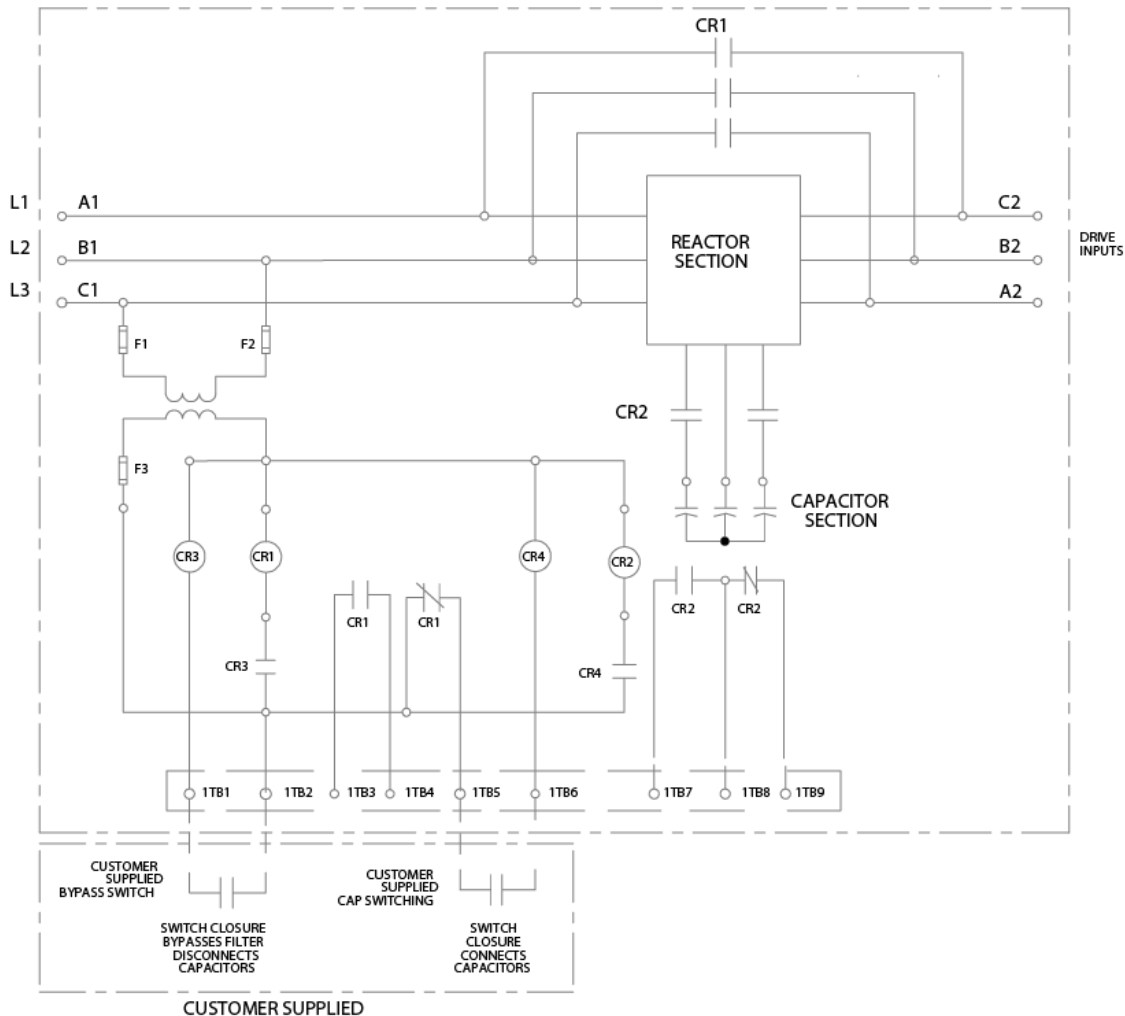

Figure 6-7: Contact Option - 013

The above contactor option diagram is provided to help understand the circuit function and does not reflect actual circuit wiring.





## Contactor Coil Switching Currents

### Option – 002

The following table indicates the 120 VAC 50/60 Hz current required to switch and hold the various size contactors used in Matrix Filter capacitor switching and bypass options. This data is provided to select the proper switch rating to remotely control the contactor and is consistent for the 400V, 480V, and 600V units.

Contactor Currents for 120 VAC 60 Hz coils.

**Table 6-1: Contactor Coil Switching Currents**

Matrix filter current Rating AMPS	Capacitor Contactor Option 002 AMPS	
	<i>INRUSH</i>	<i>SEALED</i>
6	0.341	0.054
8	0.341	0.054
11	0.341	0.054
14	0.341	0.054
21	0.341	0.054
27	0.341	0.054
34	0.341	0.054
44	0.341	0.054
52	0.341	0.054
66	0.341	0.054
83	0.341	0.054
103	0.341	0.054
128	0.922	0.064
165	1.70	0.304
208	1.70	0.304
240	2.00	0.42
320	1.41	0.025
403	1.41	0.025
482	2.08	0.036
636	2.08	0.036
786	3.75	0.036
850	3.75	0.036
1000	3.75	0.036
1200	3.75	0.036

## Torque Ratings

Matrix AP 400V, 480V, 600V

**Table 6-2: Torque Ratings-400V, 480V, 600V**

Filter Rating (Amps)	AP HMR Terminals			Cap-panel Terminals U4-V4-W4				
	Input /Output Power U1-V1-W1 / U2-V2-W2		U4-V4-W4 interconnect Cap-panel	400V Capacitor/ Cap-panel Part Number	480V Capacitor/ Cap-panel Part Number	600V Capacitor/ Cap-panel Part Number	Minimum Interconnect Wire Gauge (AWG)	Terminal Torque (in-lbs.)
	Wire Range (AWG)	Terminal Torque (in-lbs.)	Terminal Torque (in-lbs.)					
6	14 – 6	16	16	CAP-350TP	CAP-338TP	CAP-361TP	14	23
8	14 – 6	16	16	CAP-351TP	CAP-339TP	CAP-362TP	14	23
11	14 – 6	16	16	CAP-352TP	CAP-349TP	CAP-363TP	14	23
14	14 – 6	16	16	CAP-353TP	CAP-340TP	CAP-364TP	14	23
21	14 – 6	16	16	CAP-342TP	CAP-341TP	CAP-365TP	14	23
27	14 – 6	16	16	CAP-355TP	CAP-342TP	CAP-366TP	14	23
34	14 – 6	16	20	CAP-343TP	CAP-343TP	CAP-367TP	12	23
44	18 – 4	16	20	CAP-356TP	CAP-344TP	CAP-368TP	12	23
52	Flat copper tab	N/A	20	CAP-357TP	CAP-345TP	CAP-369TP	10	23
66	Flat copper tab	N/A	50	CAP-358TP	CAP-346TP	CAP-370TP	10	23
83	Flat copper tab	N/A	16	CAP-359TP	CAP-347TP	CAP-371TP	10	23
103	Flat copper tab	N/A	16	CAP-360TP	CAP-348TP	567	8	23/60
128	Flat copper tab	N/A	N/A	594	555	568	8	60
165	Flat copper tab	N/A	N/A	544	557	570	6	60
208	Flat copper tab	N/A	N/A	543	545	572	4	60
240	Flat copper tab	N/A	N/A	595	544	574	4	60
320	Flat copper tab	N/A	N/A	596	543	576	2	60
403	Flat copper tab	N/A	N/A	597	562	578	1/0	60
482	Flat copper tab	N/A	N/A	595	544	574	4	60
				595	544	754	4	60
636	Flat copper tab	N/A	N/A	596	543	576	2	60
				596	543	576	2	60
786	Flat copper tab	N/A	N/A	597	562	578	1/0	60
				597	562	578	1/0	60
850	Flat copper tab	N/A	N/A	596	543	N/A	2	60
				596	543	N/A	2	60
				595	544	N/A	4	60
1000	Flat copper	N/A	N/A	598	543	N/A	2	60

Filter Rating (Amps)	AP HMR Terminals			Cap-panel Terminals U4-V4-W4				
	Input /Output Power U1-V1-W1 / U2-V2-W2		U4-V4-W4 interconnect Cap-panel	400V Capacitor/ Cap-panel Part Number	480V Capacitor/ Cap-panel Part Number	600V Capacitor/ Cap-panel Part Number	Minimum Interconnect Wire Gauge (AWG)	Terminal Torque (in-lbs.)
	Wire Range (AWG)	Terminal Torque (in-lbs.)	Terminal Torque (in-lbs.)					
	tab							
1200	Flat copper tab	N/A	N/A	598	543	N/A	2	60
				598	561	N/A	2	60
				597	562	N/A	1/0	60
1600	Flat copper tab	N/A	N/A	N/A	563	N/A	1/0	60
				N/A	563	N/A	1/0	60
				N/A	563	N/A	1/0	60
				N/A	563	N/A	1/0	60
2000	Flat copper tab	N/A	N/A	N/A	563	N/A	1/0	60
				N/A	563	N/A	1/0	60
				N/A	563	N/A	1/0	60
				N/A	563	N/A	1/0	60
				N/A	563	N/A	1/0	60
2300	Flat copper tab	N/A	N/A	N/A	562	N/A	1/0	60
				N/A	562	N/A	1/0	60
				N/A	562	N/A	1/0	60
				N/A	562	N/A	1/0	60
				N/A	562	N/A	1/0	60
				N/A	562	N/A	1/0	60

**Note: Cap-panel interconnect wiring specification according to UL508 75° C Table.**

**Note: To prevent flexing or bending of the coil windings attached to AP HMR Flat copper terminal tabs, use two wrenches to tighten customer provided cable mounting hardware.**

## Torque Ratings Matrix AP 690V

**Table 6-3: Torque Ratings-690V**

Filter Rating (Amps)	AP HMR Terminals			Cap-panel Terminals U4-V4-W4		
	Input /Output Power U1-V1-W1 / U2-V2-W2		U4-V4-W4 interconnect Cap-panel	690V Capacitor/ Cap-panel Part Number	Minimum Interconnect Wire Gauge (AWG)	Terminal Torque (in-lbs.)
	Wire Range (AWG)	Terminal Torque (in-lbs.)	Terminal Torque (in-lbs.)			
52	Flat copper tab	N/A	N/A	622	12	60
66	Flat copper tab	N/A	N/A	612	10	60
83	Flat copper tab	N/A	N/A	613	10	60
103	Flat copper tab	N/A	N/A	615	8	60
128	Flat copper tab	N/A	N/A	617	8	60
165	Flat copper tab	N/A	N/A	619	8	60
208	Flat copper tab	N/A	N/A	614	8	60
				616	8	60
240	Flat copper tab	N/A	N/A	616	8	60
				617	8	60
320	Flat copper tab	N/A	N/A	618	6	60
				618	6	60
403	Flat copper tab	N/A	N/A	614	8	60
				618	6	60
				618	6	60
482	Flat copper tab	N/A	N/A	618	6	60
				618	6	60
				618	6	60
636	Flat copper tab	N/A	N/A	620	4	60
				621	4	60
				621	4	60

**Note: Cap-panel interconnect wiring specification according to UL508 75° C Table.**





**Note: To prevent flexing or bending of the coil windings attached to AP HMR Flat copper terminal tabs, use two wrenches to tighten customer provided cable mounting hardware.**

## 7. START UP

### Startup Checklist

#### Safety Precautions





Before startup, observe the following warnings and instructions:

 <b>WARNING</b>	<p><b>Internal components of the filter are at line potential when the filter is connected to the drive. This voltage is extremely dangerous and may cause death or severe injury if you come in contact with it.</b></p>
 <b>WARNING</b>	<p>Remove all power to the Matrix AP filter in compliance to standardized 26 CFR 1920.147 lockout/tagout policies. After disconnecting the utility power, wait at least 5 minutes before doing any work on the filter connections. After removing power, allow at least five minutes to elapse and verify that the capacitors have discharged to a safe level before contacting internal components. Connect a DC voltmeter across the capacitor terminals and ensure that the voltage is at a safe level.</p>
 <b>WARNING</b>	<p><b>Use extreme caution to avoid contact with line voltage when checking for power. INJURY OR DEATH MAY RESULT IF SAFETY PRECAUTIONS ARE NOT OBSERVED.</b></p>
 <b>WARNING</b>	<p>After disconnecting the utility power, wait at least 5 minutes before doing any work on the filter connections. After removing power, allow at least five minutes to elapse and verify that the capacitors have discharged to a safe level before contacting internal components. Connect a DC voltmeter across the capacitor terminals. Start with the meter on the highest scale and progressively switch to a lower scale as the indicated voltage falls below the maximum value of the scale used.</p>
 <b>WARNING</b>	<p><b>Injury or death may result if the drive safety precautions are not observed. Damage to equipment may occur if the drive startup procedures are not observed.</b></p>

## Sequence of Operation

1. Read and follow safety precautions.
2. After installation, ensure that:
  - All filter ground terminals are connected to ground.
  - Power wiring to the utility, drive and motor is in accordance with the power wiring connection diagrams shown in installation instructions section. Use the guidelines of Table 6-2 (p49) for 400 - 600V and Table 6-3 (p51) for 690V, for power and cap-panel wire gauges.
3. Check that moisture has not condensed on the filter components. If moisture is present, do not proceed with startup until the moisture has been removed.
4. Disconnect the filter output from the drive.
5. Connect the filter to the utility.
6. Confirm that line voltage is present at the input terminals (U, V1, W1) of the filter.
7. Confirm that line voltage is present at the output terminals (U2, V2, W2) of the filter and that it is less than or equal to 1.05 times the input voltage.
8. Using a clamp on Amp meter, check input phase currents to verify they are within a 5% match to each other and approximately 30% of filter current rating.
9. Remove power and verify that **NO VOLTAGE** is present on the filter terminals.
10. Connect the filter output to the drive.
11. Refer to the drive user manual for the drive startup procedure. Observe all safety instructions in the drive user manual.

## 8. TROUBLESHOOTING

 <b>WARNING</b>	<b>INJURY OR DEATH MAY RESULT IF THE DRIVE SAFETY PRECAUTIONS ARE NOT OBSERVED.</b>
 <b>WARNING</b>	When properly installed, this equipment has been designed to provide maximum safety for operating personnel. However, hazardous voltages and elevated temperatures exist within the confines of the enclosure. Servicing should therefore be performed by <b>qualified personnel only and in accordance with OSHA Regulations.</b>
 <b>WARNING</b>	<b>High voltage is used in the operation of this filter. Use Extreme caution to avoid contact with high voltage when operating, installing or repairing this filter. INJURY OR DEATH MAY RESULT IF SAFETY PRECAUTIONS ARE NOT OBSERVED.</b>
 <b>Caution</b>	After removing power, allow at least five minutes to elapse and verify that the capacitors have discharged to a safe level before contacting internal components. Connect a DC voltmeter across the capacitor terminals or terminals U1, V1 or V1, W1 and ensure that the voltage is at a safe level.

To aid in troubleshooting, two interconnection diagrams, Modular Unit Interconnection Diagram

Figure 6-2 (p41) and Enclosed Unit Interconnection Diagram

Figure 6-3 (p42) are included, and this table below list potential problems and solutions.

## Matrix AP Harmonic Filter Field Checks

1. Read and understand the voltage appropriate MTE Matrix Filter user manual. These manuals may be downloaded from the [www.mtecorp.com](http://www.mtecorp.com) web site. Locate figures and drawings for your particular filter and identify the terminal locations.
2. Disconnect all power and remove input power wiring from U1, V1, W1 terminals.
3. Remove VFD drive power connections from filter terminals U2, V2, W2 and any contactor or temperature switch wiring. (For filters using control transformers: remove power fuses on top of transformer.)
4. Visually inspect filter terminals and wiring lugs for signs of heat and corrosion. **Contact factory if any wires appear to be missing or cut!**
5. Inspect the U4, V4, W4 capacitor interconnect terminals and wiring.
6. Visually inspect all capacitors for signs of case deformation, bowing of the top, leaking oil or terminal damage. Note the CAP- # and date code of any damaged capacitors.
7. Using a multi meter set to read 100K ohms check:
  - a. Phase to phase U1-V1-W1-U1 (mechanically activate contactor if present) after reactor and caps charge reading should be about 40K (total equivalent breeder resistance value) and should be the same for each phase. Open circuit or very low readings indicate a problem.
  - b. Phase to chassis U1- case, V1-case, W1- case; low readings indicate a ground fault problem.
8. Ensure the “disconnect” is safe, then wire the utility power to U1, V1, W1.
9. Apply power and verify that proper output voltage is present on U2, V2, and W2.
10. Using a clamp on amp meter read the filter input current:
  - a. Readings will be 0.5 of the capacitor current listed in Table 3-3 (p11) (400V), Table 3-8 (p17) (480V), Table 3-13 (p23) (600V) and Table 3-17 (p27) (690V) for the listed filter current in the user manual (mechanically activate the contactor if the filter is equipped with one). Readings should be the same (+/- 5%) for all phase currents; **contact the factory if currents are out of tolerance!**
  - b. Open contactor readings will show zero current for all phases.
11. Disconnect filter power and wire the VFD to U2, V2, and W2 as well as any control wiring to the filter contactor or temperature switch. Replace any control transformer fuses. Follow the drive power startup guidelines in the drive manufacturer’s user manual.



**Table 8-1: Troubleshooting Guide**

<b>PROBLEM:</b>		<b>Line voltage is not present at the filter output terminals.</b>
<b>Possible cause:</b>	Power to the filter is turned off.	
<b>Solution:</b>	Turn power on.	
<b>Possible cause:</b>	One or more external line fuses are blown.	
<b>Solution:</b>	Verify the continuity of line fuses in all phases. Replace as necessary.	
<b>PROBLEM:</b>		<b>Full Load Harmonic current distortion exceeds 5% on one or more phases at full load.</b>
<b>Possible cause:</b>	The capacitor assembly has not been connected.	
<b>Solution:</b>	Check interconnection of capacitor assembly with AP HMR. Figure 6-2 (p41) and Figure 6-1 (p40)	
<b>Possible cause:</b>	A capacitor has failed.	
<b>Solution:</b>	Inspect the tops of all capacitors for bowing. Replace failed capacitors.	
<b>Possible cause:</b>	Source impedance is less than 1.5%.	
<b>Solution:</b>	Add a minimum 1.5% impedance line reactor to the filter input.	
<b>Possible cause:</b>	Input source voltage harmonic distortion.	
<b>Solution:</b>	Identify equipment causing harmonic voltage distortion and add filters as required or accept elevated THVD.	
<b>Possible cause:</b>	Line voltage unbalance exceeds 1%.	
<b>Solution:</b>	Balance input line voltage to 1% or less.	
<b>PROBLEM:</b>		<b>Filter output voltage is not within specification</b>
<b>Possible cause:</b>	Filter input voltage is not within specification.	
<b>Solution:</b>	Check the AC input line voltage and verify that it is within tolerance. Refer to the filter service conditions and performance specifications for tolerances.	
<b>Possible cause:</b>	Source impedance is out of tolerance.	
<b>Solution:</b>	Verify that the source impedance is within tolerance. Refer to the filter service conditions and performance specifications for tolerances.	
<b>Possible cause:</b>	Source impedance is out of tolerance.	
<b>Solution:</b>	Verify that the source impedance is within tolerance. Refer to the filter service conditions and performance specifications for tolerances.	
<b>Possible cause:</b>	One or more Capacitors is damaged.	
<b>Solution:</b>	Visually check capacitor top for distortion or doming. Check for shorts or open caps. Replace failed capacitors.	
<b>Possible cause:</b>	Drive set up parameter does not allow for input filter	
<b>Solution:</b>	Consult drive manufacturer to update setup to accommodate input filter.	
<b>Possible cause:</b>	Input voltage subject to extreme transients such as switching between two voltage sources. Drive faults on over or under voltage.	
<b>Solution:</b>	Source switching is not recommended without proper phase synchronizing or allowing reasonable time delay before transfer to new source.	

# APPENDIX

## Reference Drawings

## AP HMR Mounting & Terminal Locations

AP HMR 6 – 44 Amp (400V & 480V)

AP HMR 6 – 34 Amp (600V)

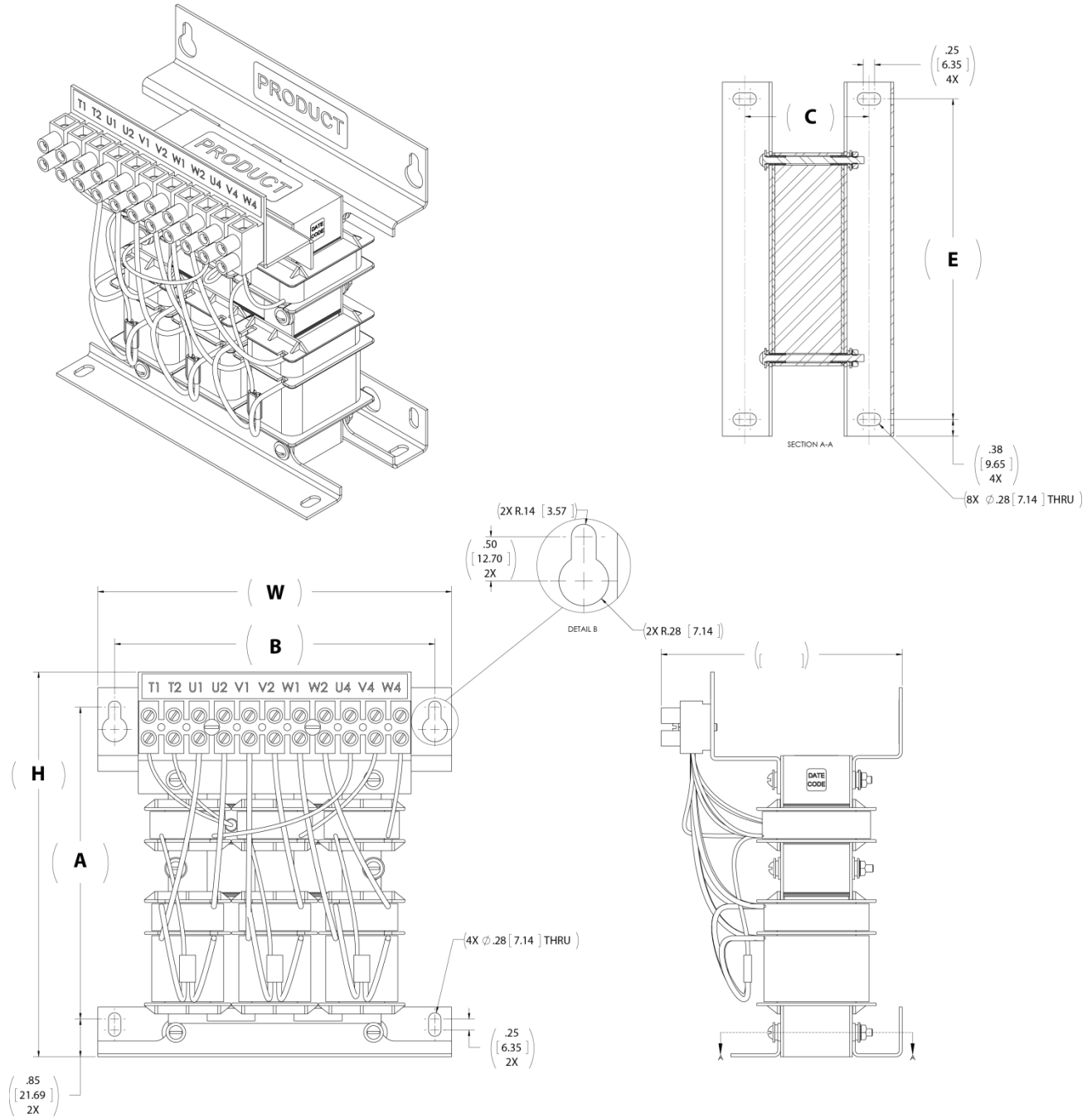

DWG\_MNL\_0001 Rev1

Figure A-1

Refer to the MTE website, [www.mtecorp.com](http://www.mtecorp.com), for detailed specifications.

## AP HMR Mounting & Terminal Locations

### AP HMR 52 – 66 Amp (690V)

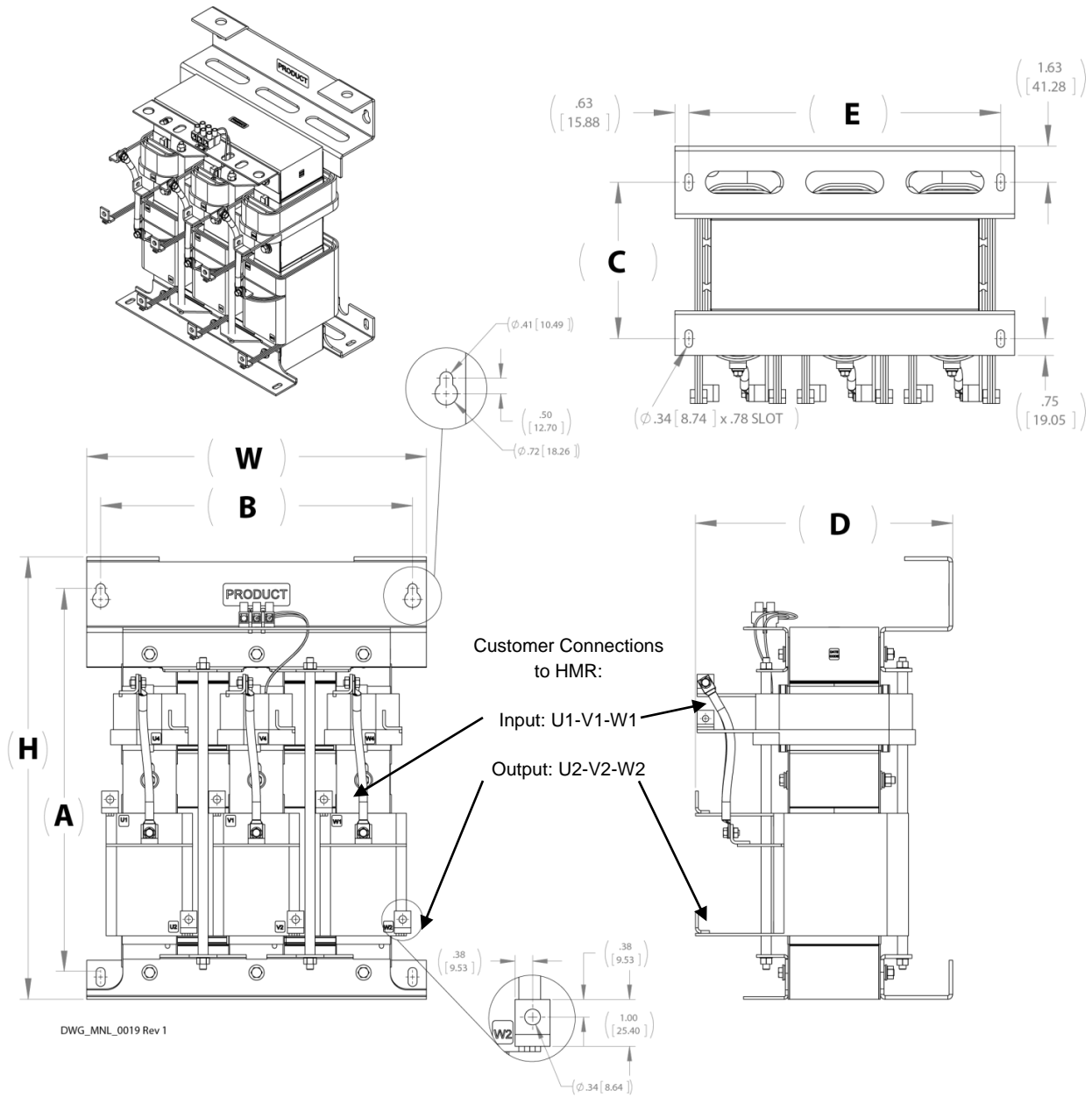

Figure A- 2

Refer to the MTE website, [www.mtecorp.com](http://www.mtecorp.com), for detailed specifications.

## AP HMR Mounting & Terminal Locations

AP HMR 52 - 103 Amp (400V & 480V)

AP HMR 44 - 83 Amp (600V)

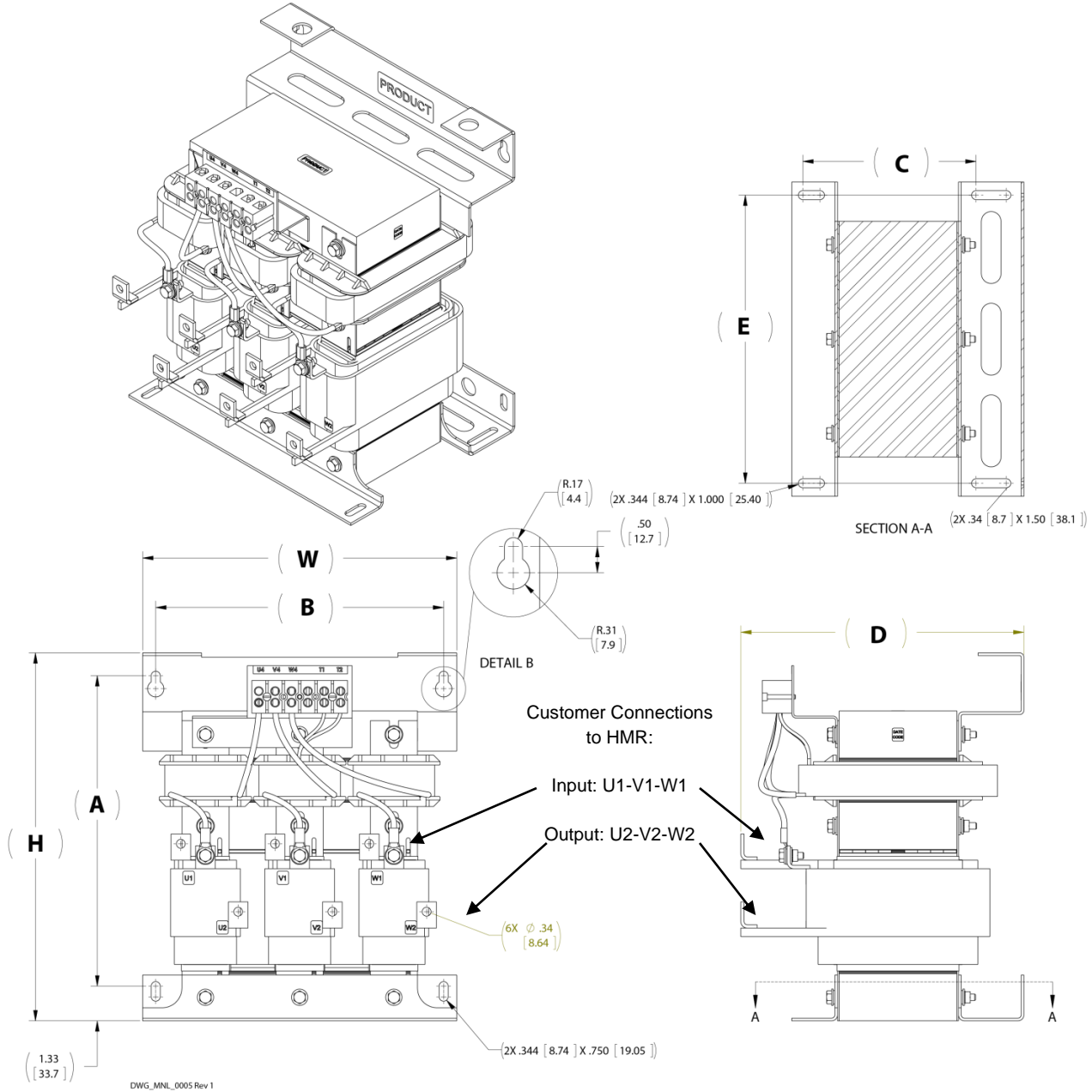

Figure A-3

Refer to the MTE website, [www.mtecorp.com](http://www.mtecorp.com), for detailed specifications.

## AP HMR Mounting & Terminal Locations

### AP HMR 83 - 103 Amp (690V)

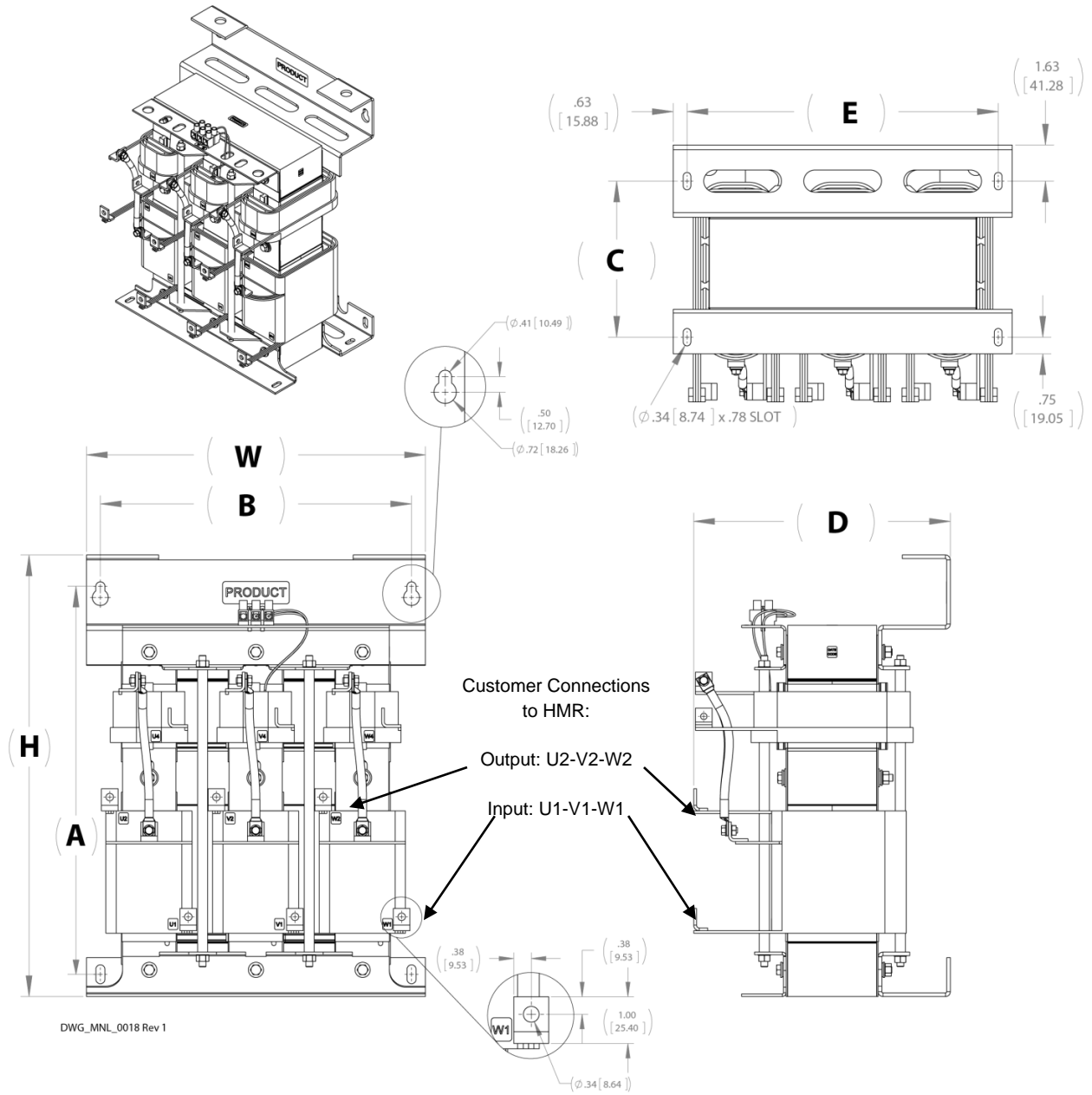

Figure A- 4

Refer to the MTE website, [www.mtecorp.com](http://www.mtecorp.com), for detailed specifications.

## AP HMR Mounting & Terminal Locations

AP HMR 128 - 320 Amp (400V & 480V)  
 AP HMR 103 – 208 Amp (600V)  
 AP HMR 128 – 165 Amp (690V)

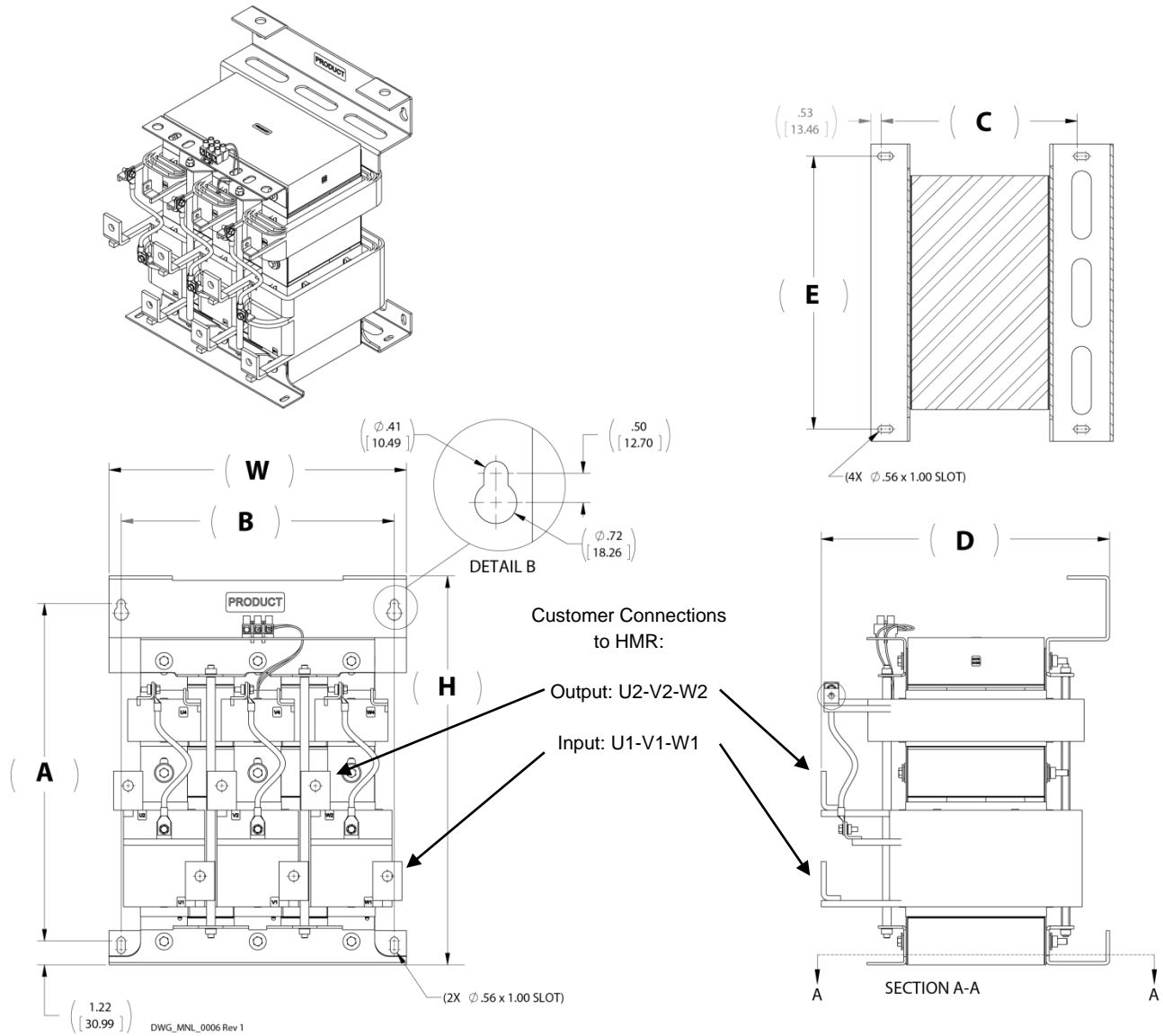

Figure A- 5

Refer to the MTE website, [www.mtecorp.com](http://www.mtecorp.com), for detailed specifications.

## AP HMR Mounting & Terminal Locations

### AP HMR 208 – 240 Amp (690V)

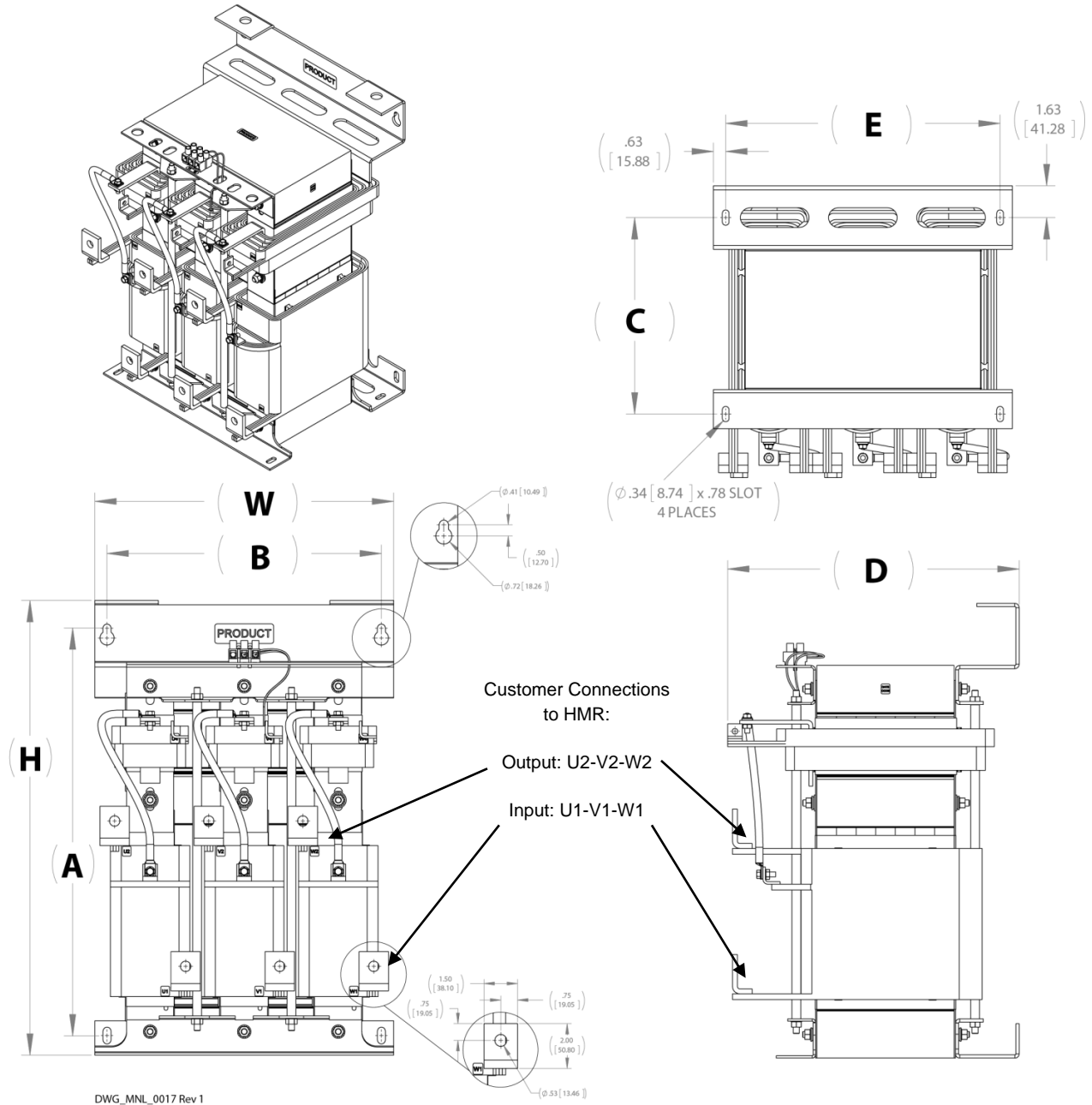

Figure A- 6

Refer to the MTE website, [www.mtecorp.com](http://www.mtecorp.com), for detailed specifications.



## AP HMR Mounting & Terminal Locations

AP HMR 403 - 482 Amp (400V & 480V)

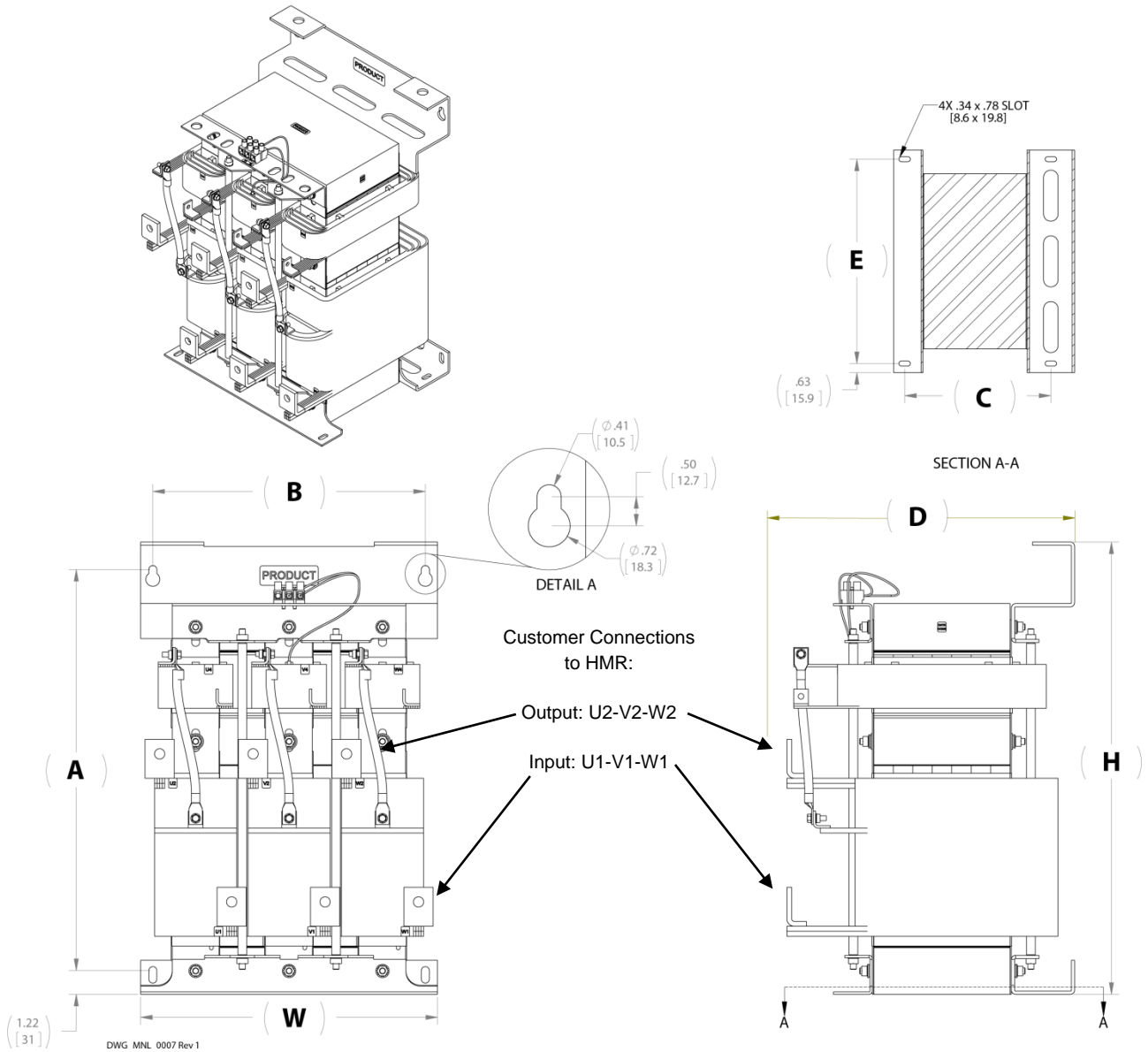

Figure A- 7

Refer to the MTE website, [www.mtecorp.com](http://www.mtecorp.com), for detailed specifications.

## AP HMR Mounting & Terminal Locations

### AP HMR 240 – 403 Amp (600V)

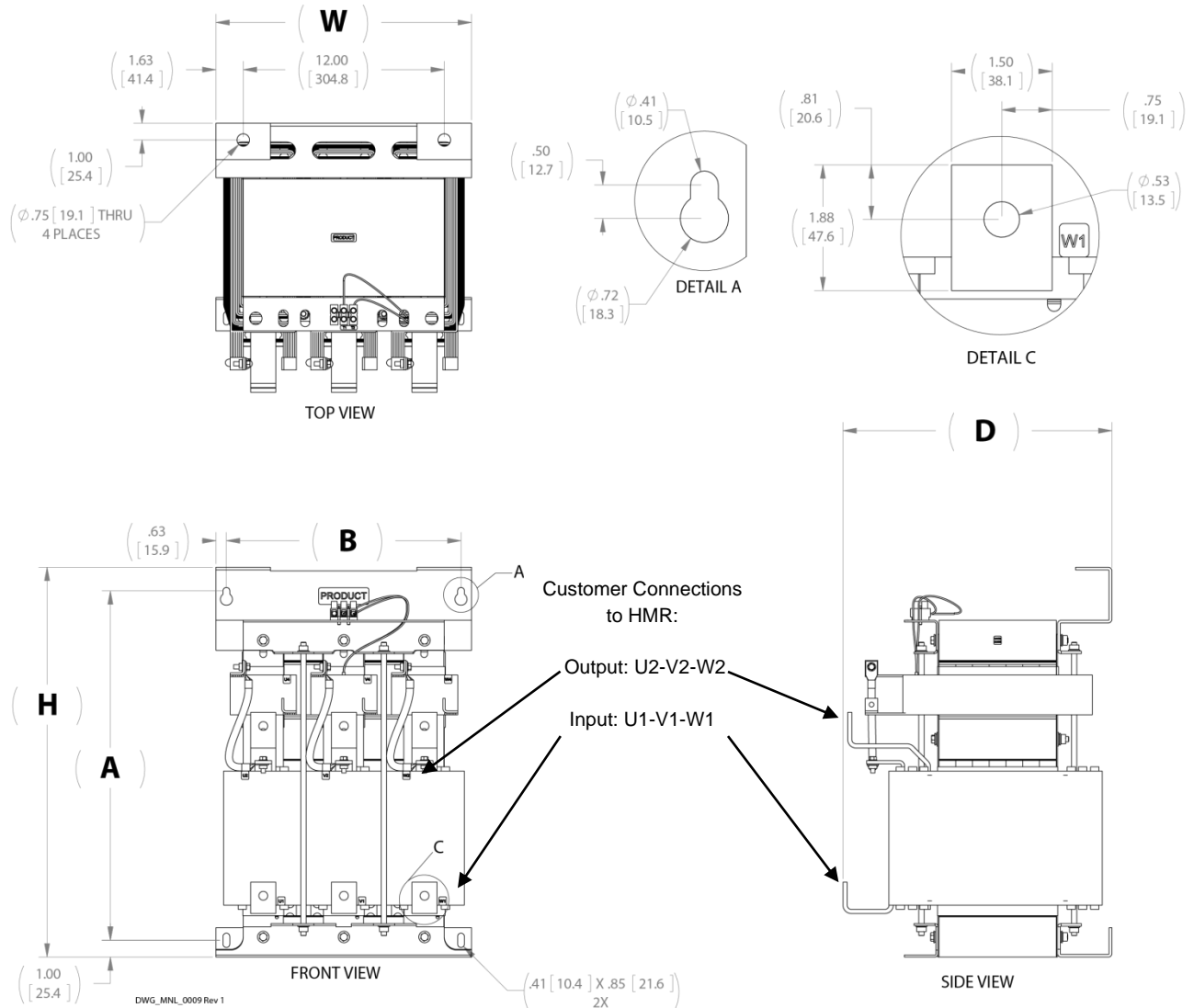

Figure A- 8

Refer to the MTE website, [www.mtecorp.com](http://www.mtecorp.com), for detailed specifications.

## AP HMR Mounting & Terminal Locations

### AP HMR 320 – 482 Amp (690V)

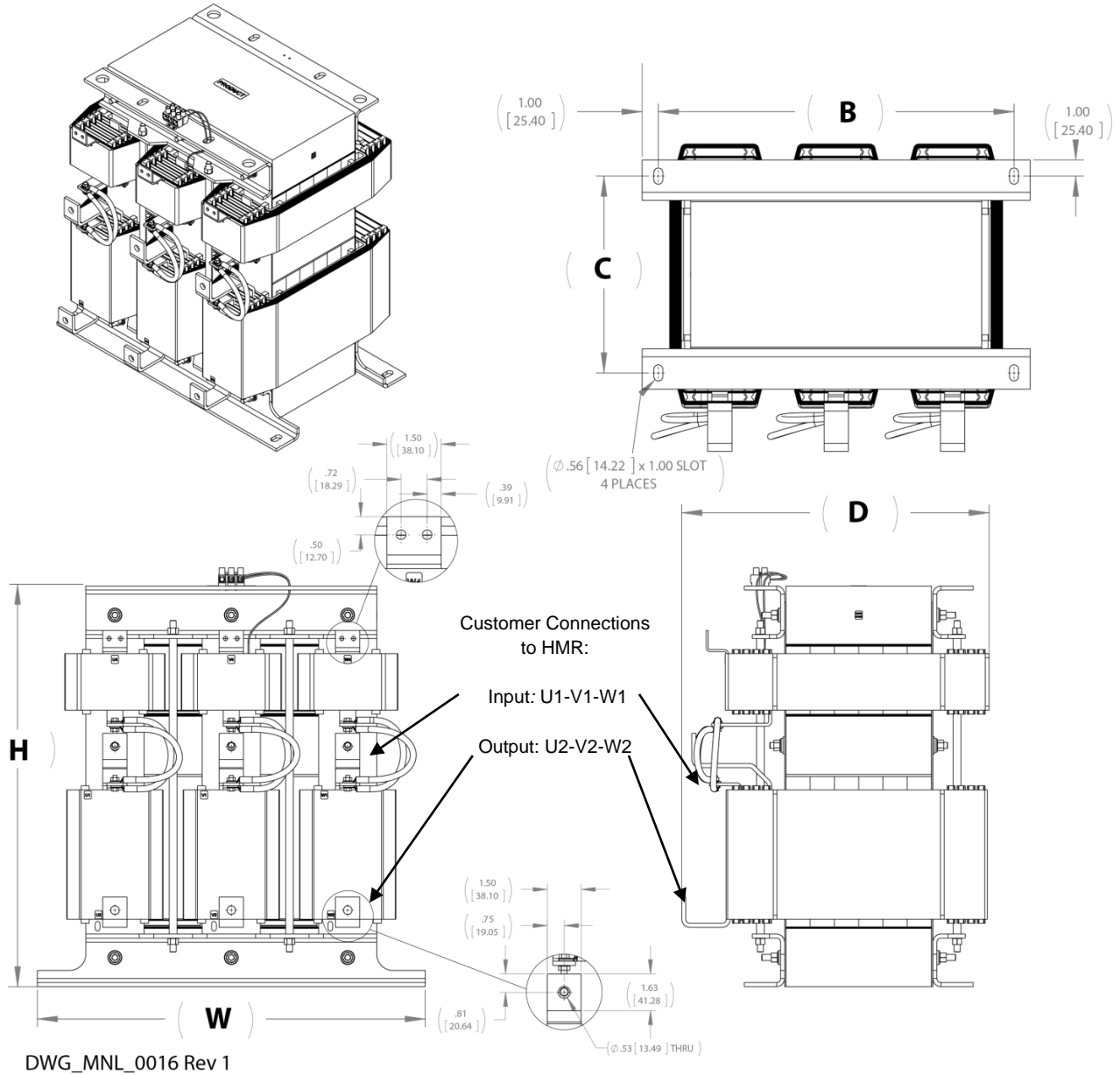

Figure A-9

Refer to the MTE website, [www.mtecorp.com](http://www.mtecorp.com), for detailed specifications.

## AP HMR Mounting & Terminal Locations

AP HMR 482 – 786 Amp (600V)

AP HMR 636 Amp (690V)

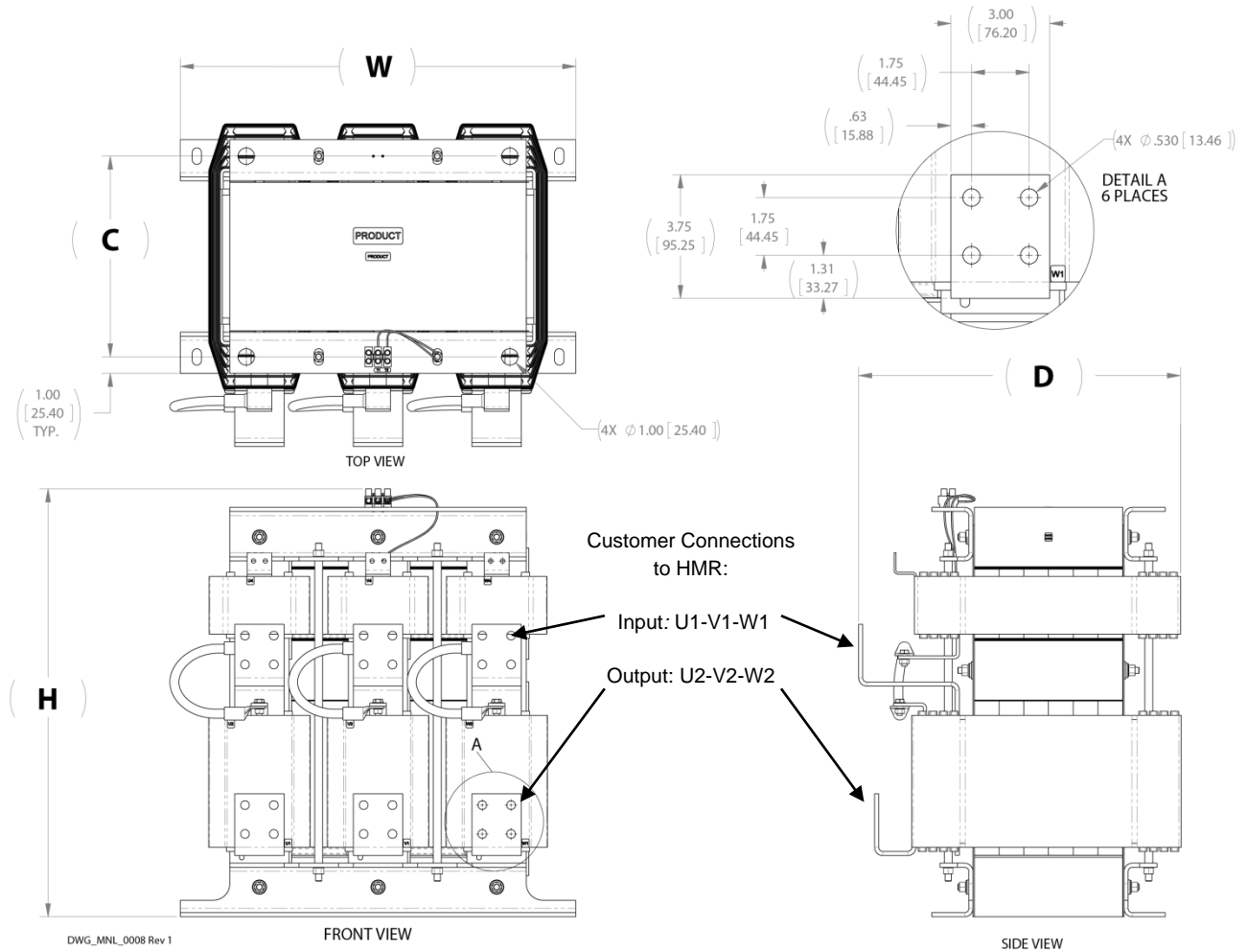

Figure A- 10

Refer to the MTE website, [www.mtecorp.com](http://www.mtecorp.com), for detailed specifications.

## AP HMR Mounting & Terminal Locations

### AP HMR 636 - 1200 Amp (400V & 480V)

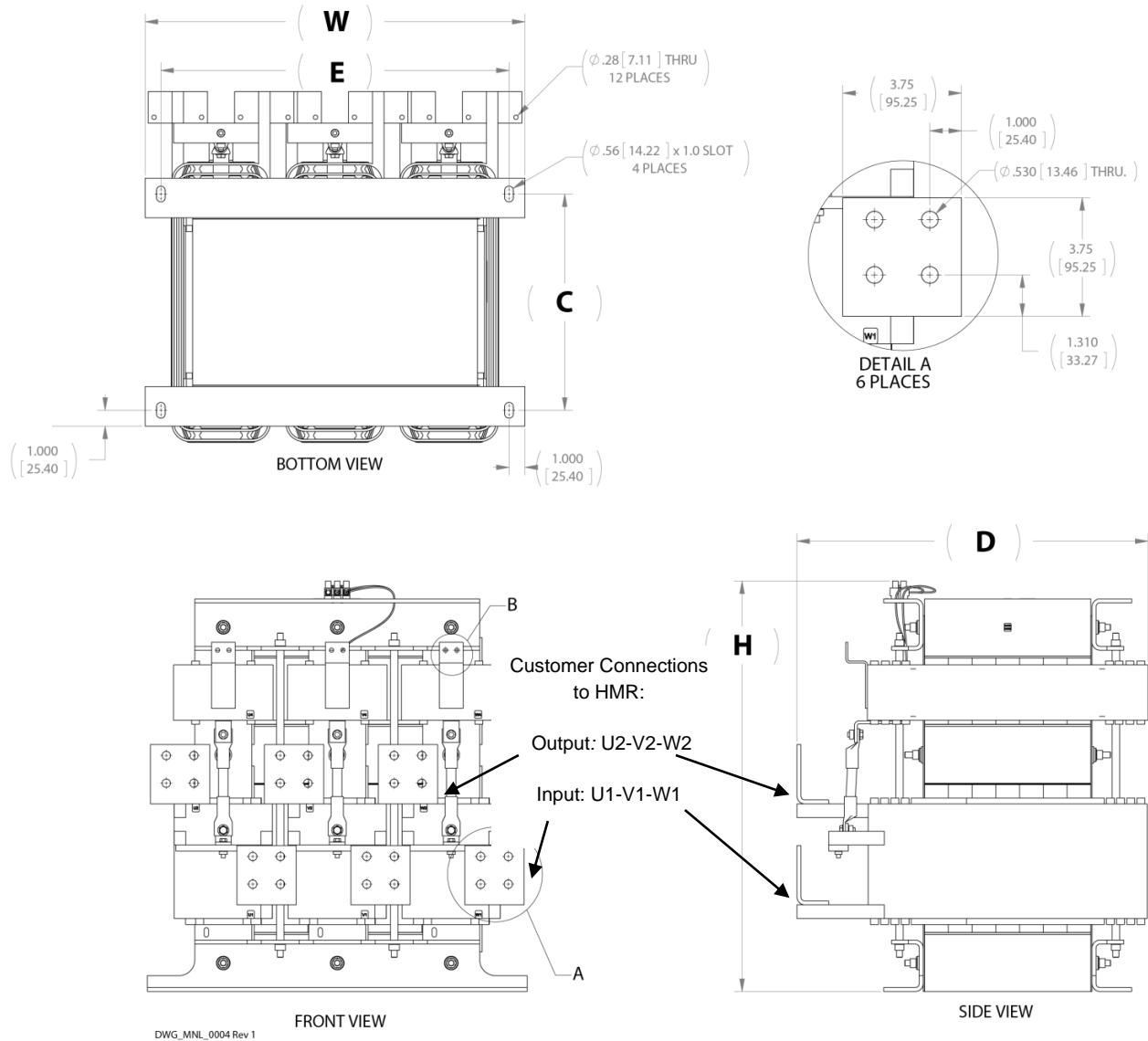

Figure A- 11

Refer to the MTE website, [www.mtecorp.com](http://www.mtecorp.com), for detailed specifications.

## AP HMR Mounting & Terminal Locations

### AP HMR 1600 - 2300 Amp (480V)

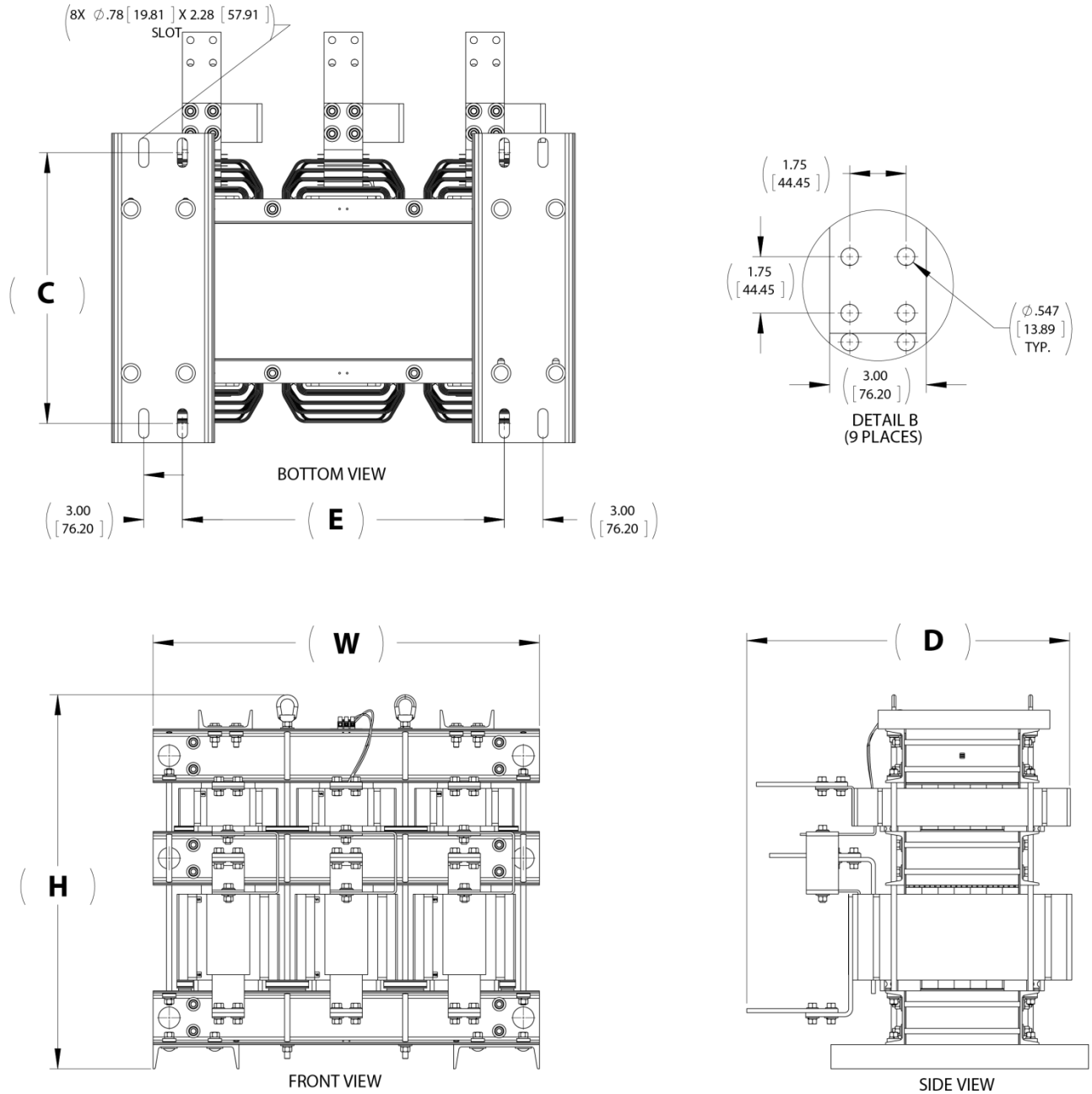

Figure A- 12

Refer to the MTE website, [www.mtecorp.com](http://www.mtecorp.com), for detailed specifications.

### Cap-Assembly Mounting & Terminal Locations

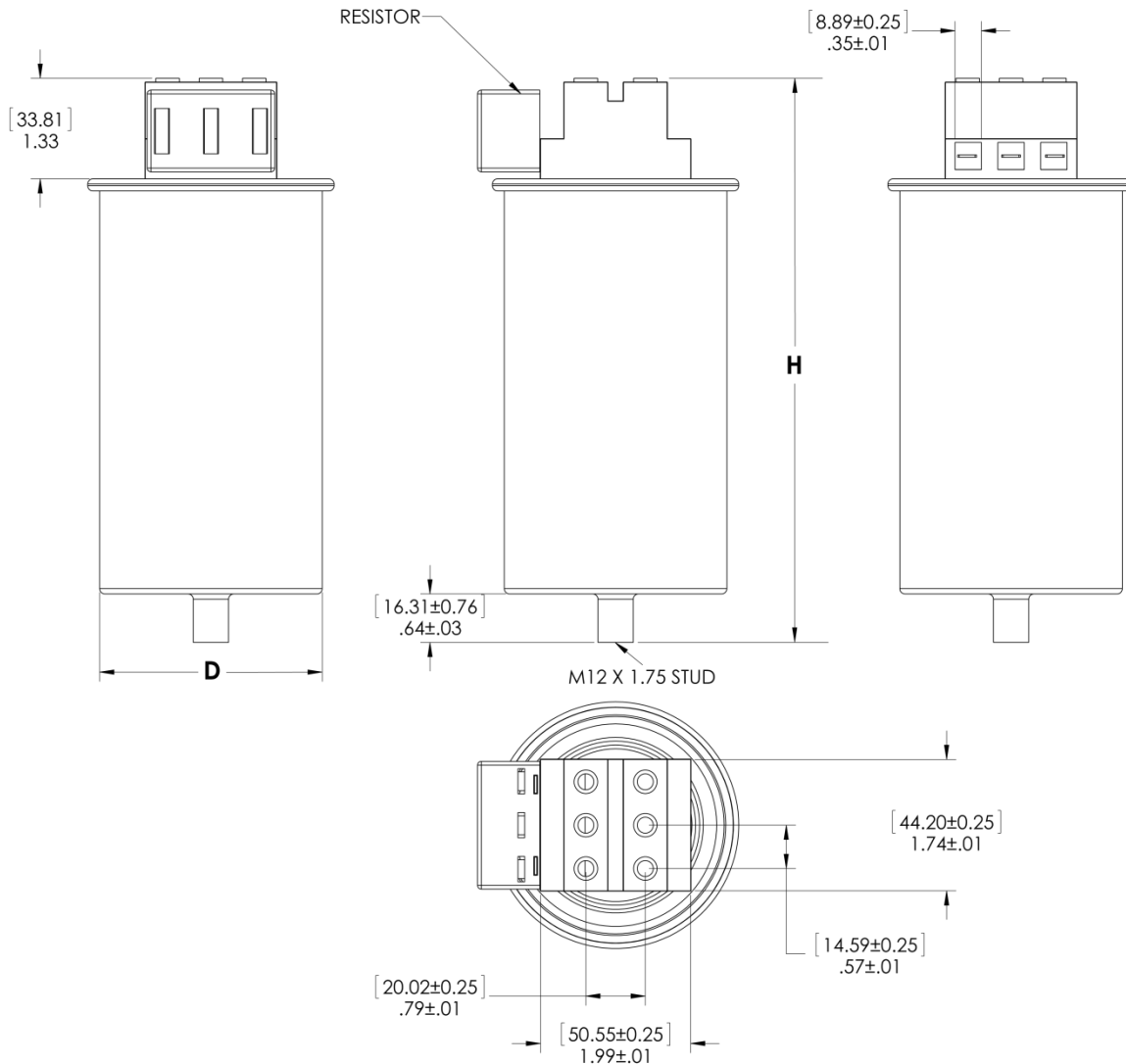

Figure A- 13

#### 1 - Three Phase Capacitor

Refer to the MTE website, [www.mtecorp.com](http://www.mtecorp.com), for detailed specifications.

**Note:** Height of capacitor will vary depending on the size of the filter.

## Cap-Assembly Mounting & Terminal Locations

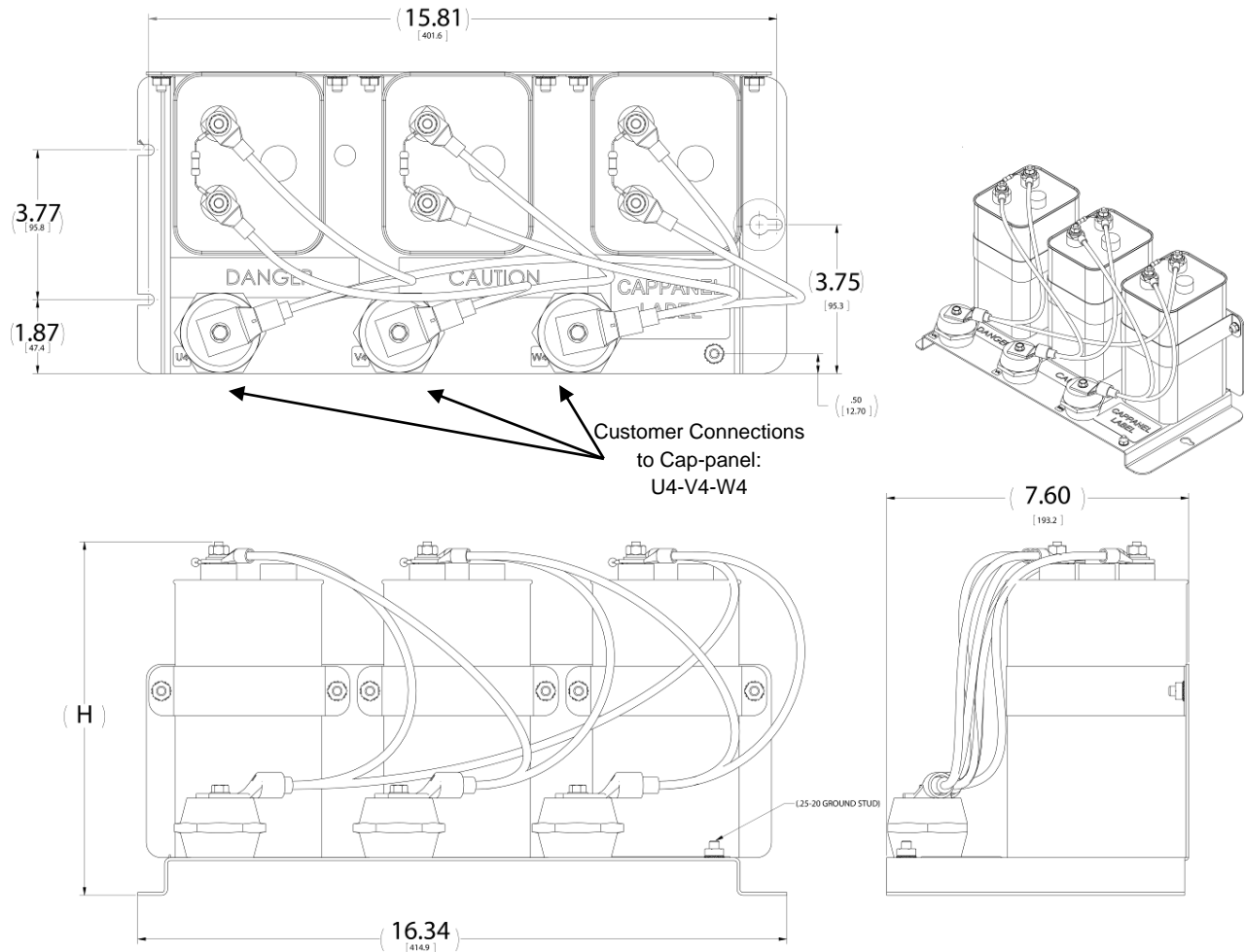

Figure A-14

### 3 – High Current Capacitor Panel

Refer to the MTE website, [www.mtecorp.com](http://www.mtecorp.com), for detailed specifications.

**Note:** Height of capacitors will vary depending on the size of the filter. 690V WYE connection for W4



### Enclosed Unit External Details

#### CAB-12AP

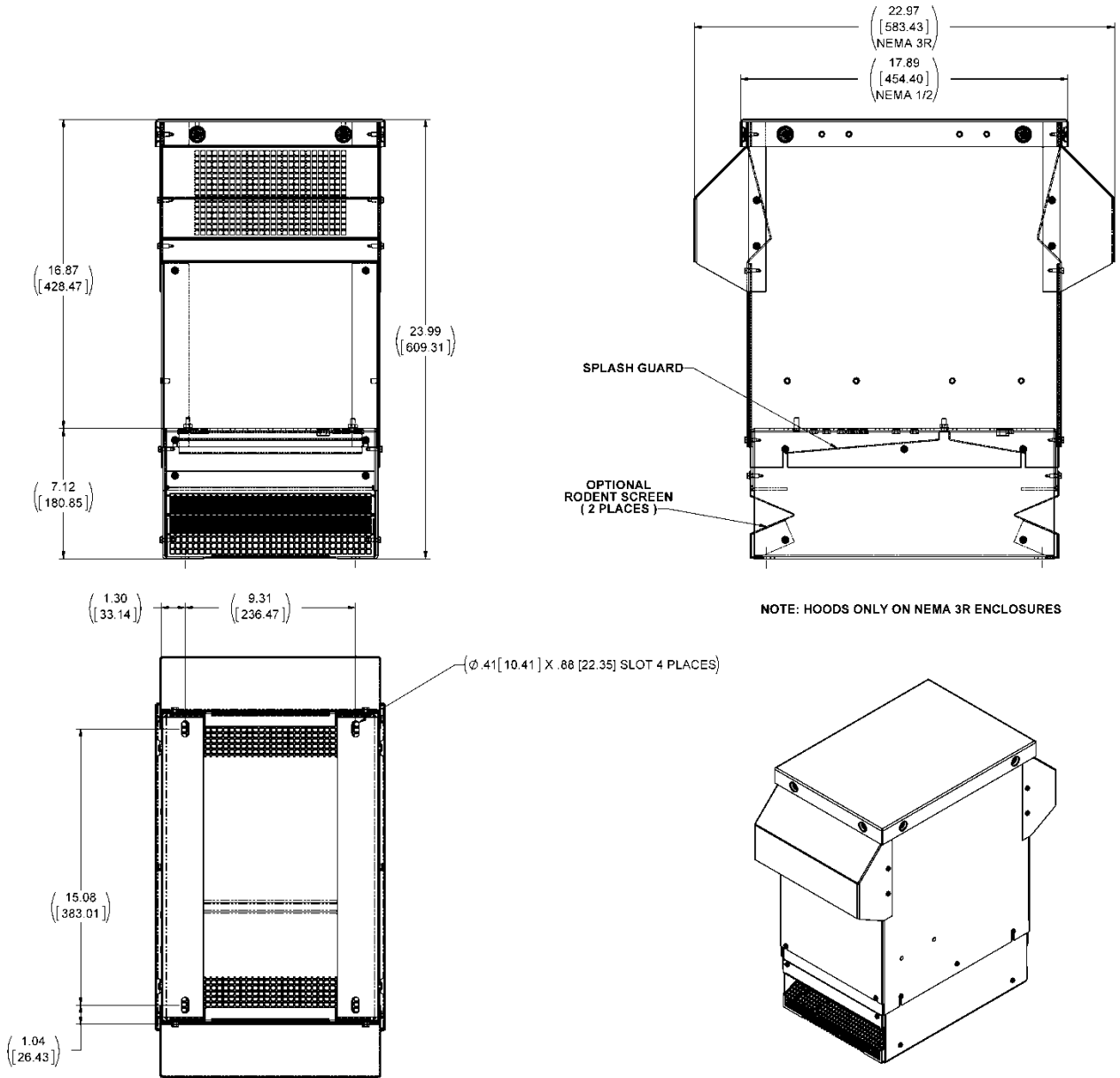

Figure A- 15

Refer to the MTE website, [www.mtecorp.com](http://www.mtecorp.com), for detailed specifications.

### Enclosed Unit External Details

CAB-17AP

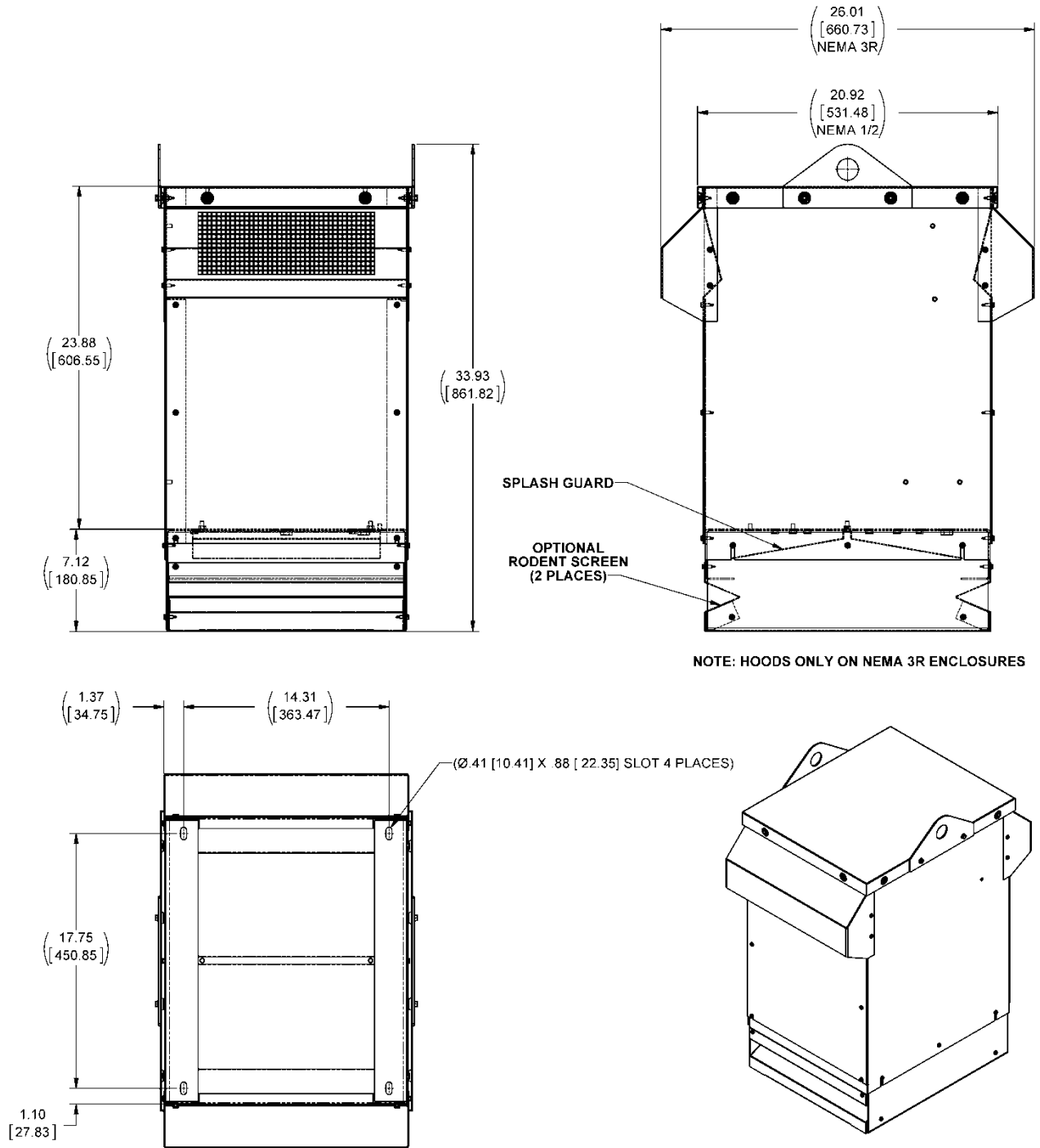

Figure A- 16

Refer to the MTE website, [www.mtecorp.com](http://www.mtecorp.com), for detailed specifications.

### Enclosed Unit External Details

#### CAB-26AP

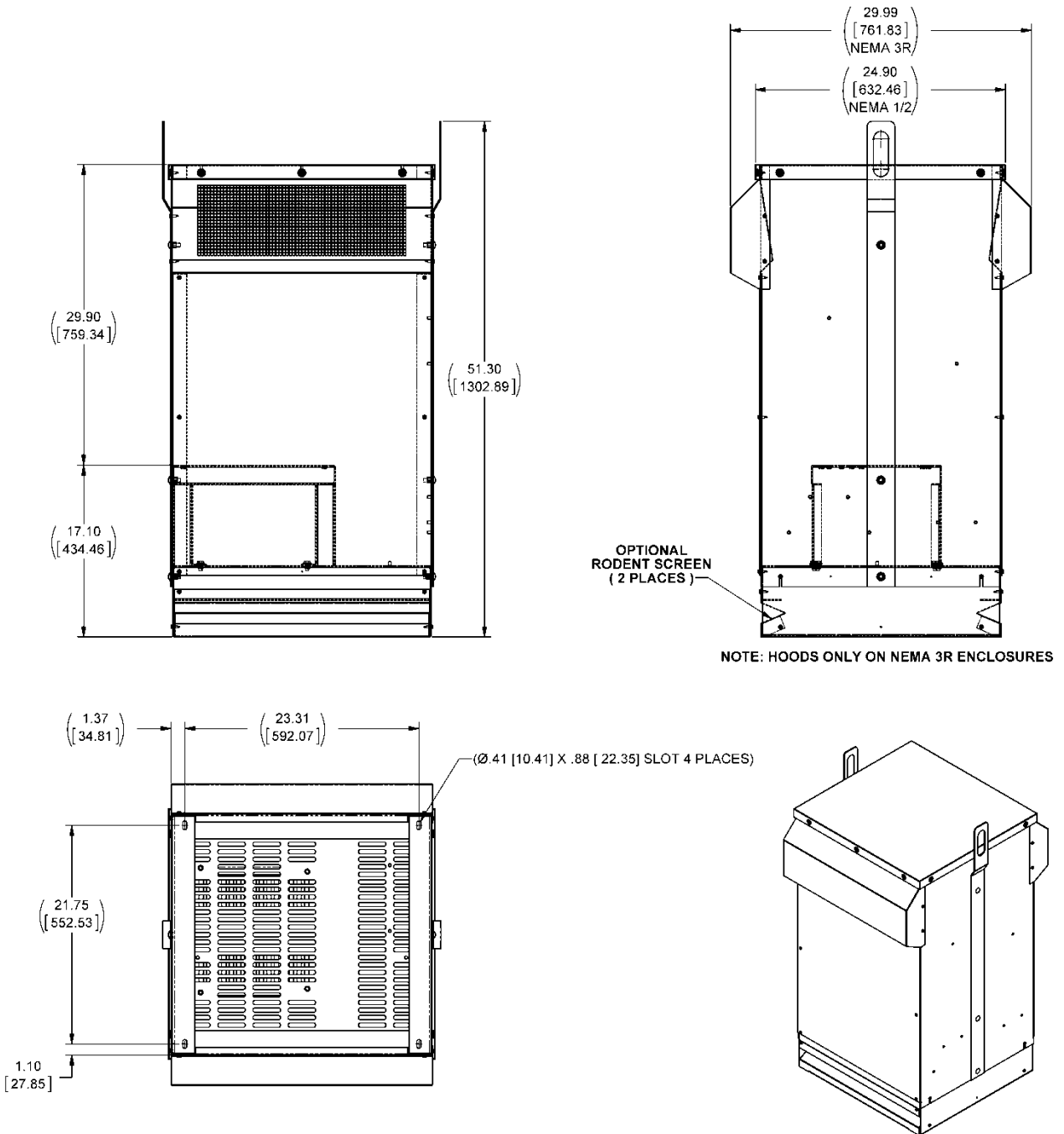

Figure A- 17

Refer to the MTE website, [www.mtecorp.com](http://www.mtecorp.com), for detailed specifications.

### Enclosed Unit External Details

CAB-26APD

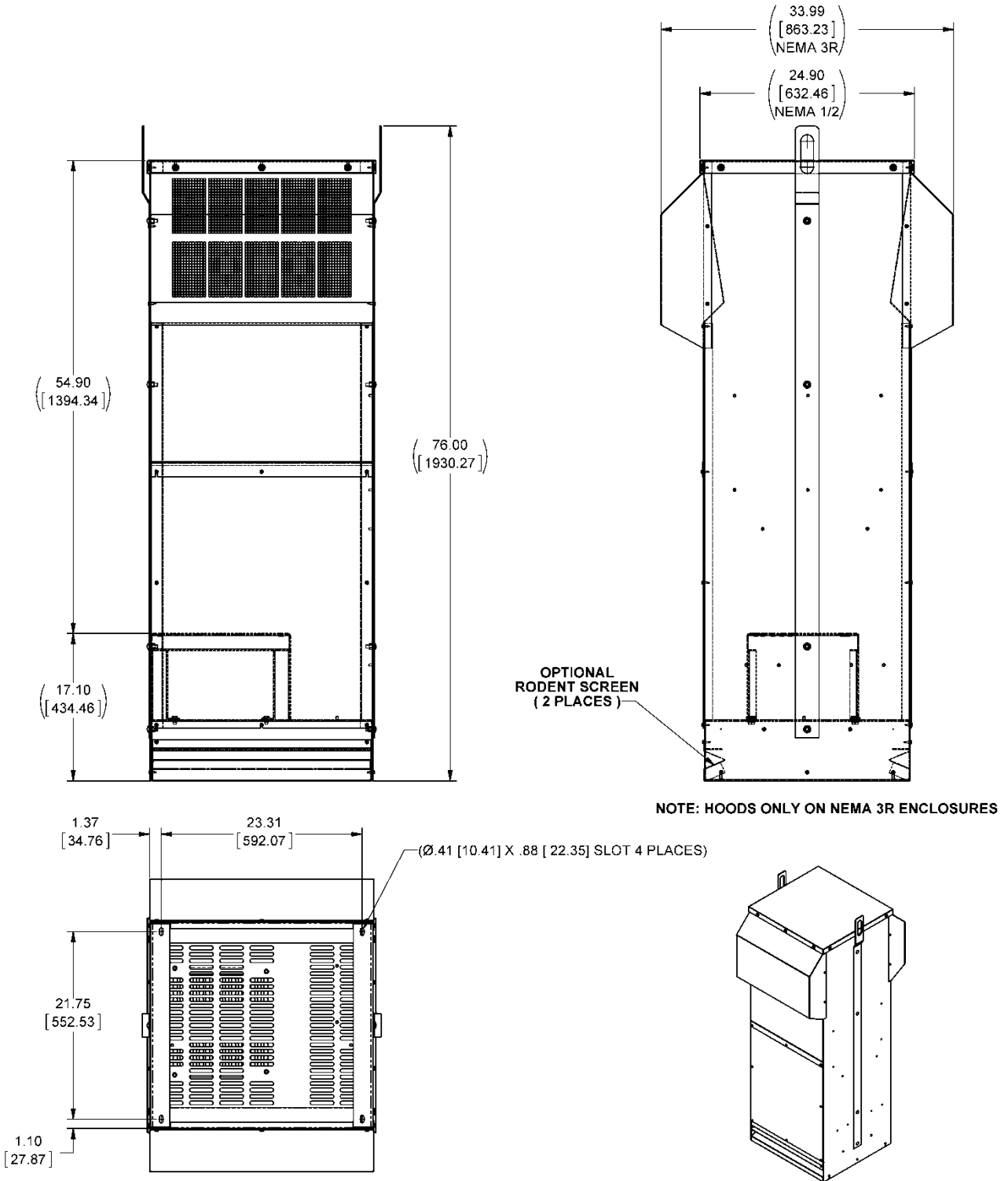

Figure A- 18

Refer to the MTE website, [www.mtecorp.com](http://www.mtecorp.com), for detailed specifications.

### Enclosed Unit External Details

#### CAB-42AP

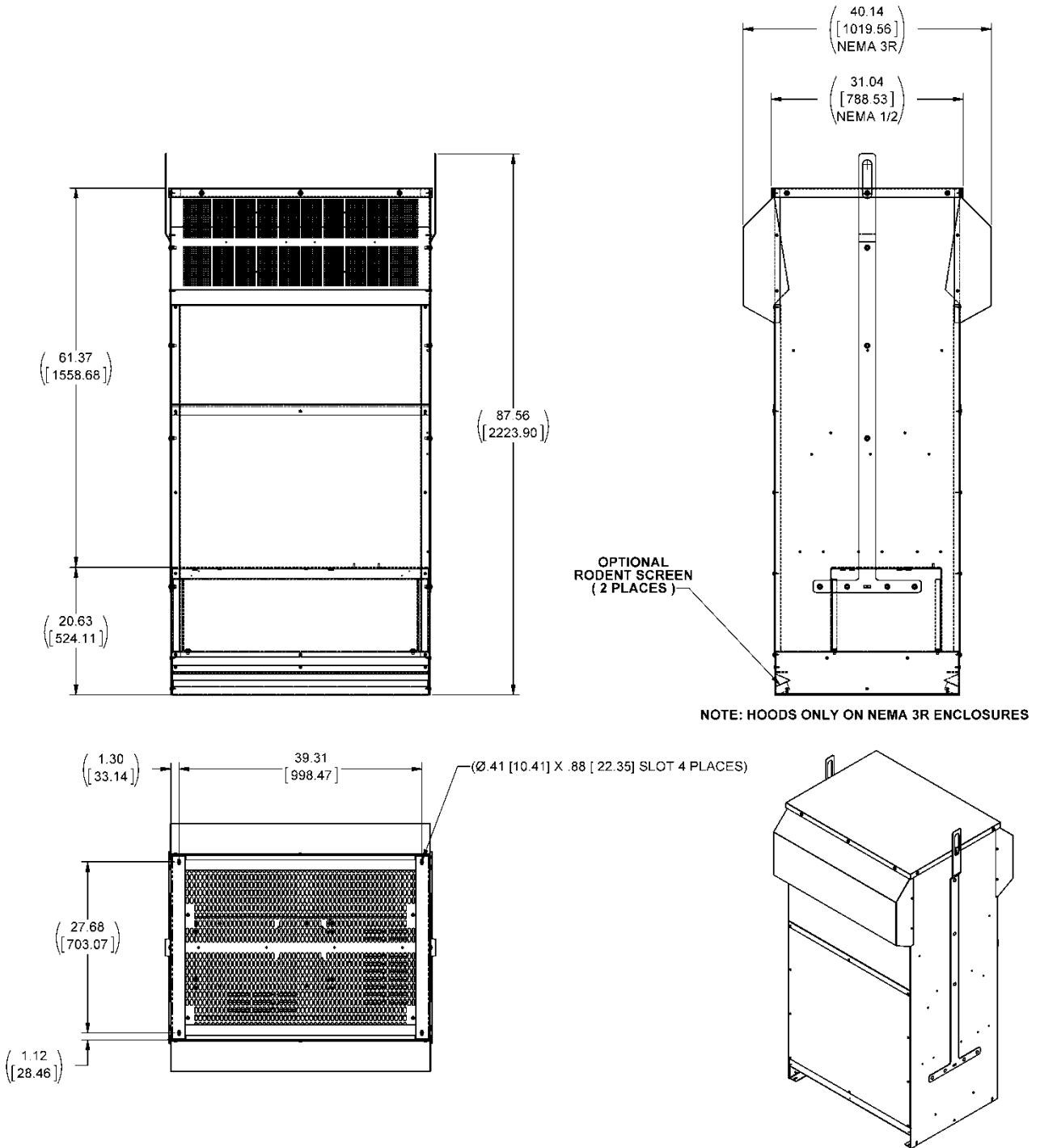

Figure A- 19

Refer to the MTE website, [www.mtecorp.com](http://www.mtecorp.com), for detailed specifications.

### Enclosed Unit External Details

#### CAB-48AP

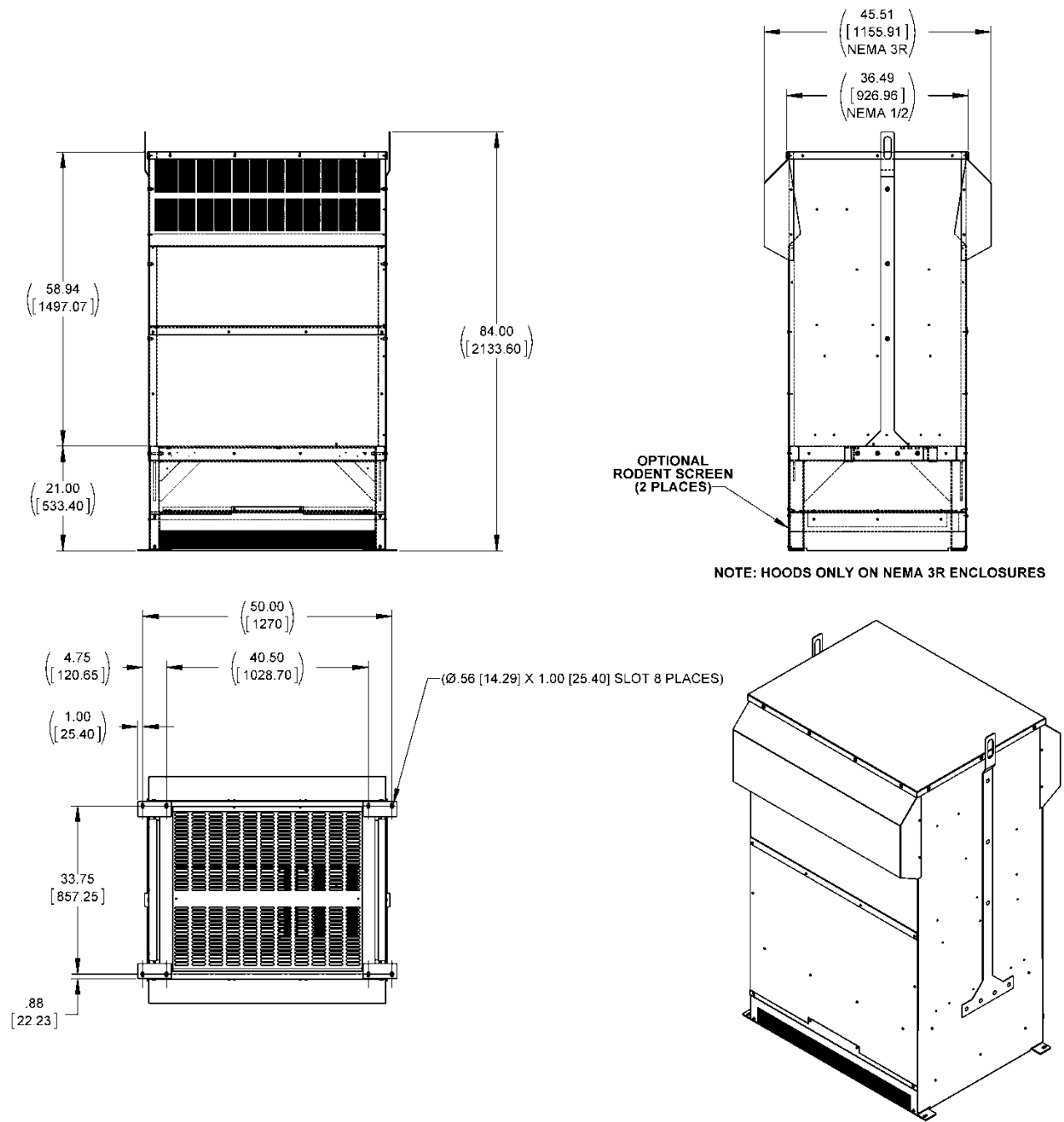

Figure A- 20

Refer to the MTE website, [www.mtecorp.com](http://www.mtecorp.com), for detailed specifications.