



Human Machine Interface Installation Guide

XGT Panel

- iXP2-08□□A(D)
- iXP2-10□□A(D)
- iXP2-12□□A(D)
- iXP2-15□□A(D)



This installation guide provides simple function information of HMI control. Please read carefully this data sheet and manuals before using products. Especially read safety precautions and handle the products properly.

1 Safety precautions

Meaning of warning and caution inscription

	WARNING	WARNING indicates a potentially hazardous situation which, if not avoided, could result in death or serious injury
	CAUTION	CAUTION indicates a potentially hazardous situation which, if not avoided, may result in minor or moderate injury. It may also be used to alert against unsafe practices

- WARNING**
- Do not contact the terminals while the power is applied.
 - Protect the product from being gone into by foreign metallic matter.
 - Do not manipulate the battery.(Charge, disassemble, hitting, short, soldering)

- CAUTION**
- Be sure to check the rated voltage and terminal arrangement before wiring.
 - When wiring, tighten the screw of terminal block with the specified torque range.
 - Do not install the flammable things on surroundings.
 - Do not use the HMI in the environment of direct vibration.
 - Except expert A/S staff, do not disassemble or fix or modify the product.
 - Use the HMI in an environment that meets the general specifications contained in this datasheet.
 - Be sure that external load does not exceed the rating of output module.
 - When disposing of HMI and battery, treat it as industrial waste.

2 Use of Environment

To install, observe the below conditions.

No	Item	Specification	Standard				
1	Ambient temp.	0°C ~ 50°C	-				
2	Storage temp	-20°C ~ 60°C	-				
3	Ambient humidity	10 ~ 85%RH, non-condensing	-				
4	Storage humidity	10 ~ 85%RH, non-condensing	-				
5	Vibration Resistance	Occasional vibration		10 times in each direction for X, Y, Z	IEC 61131-2		
		Frequency	Acceleration			Amplitude	Count
		5 ≤ f < 9Hz	-			3.5mm	-
		9 ≤ f ≤ 150Hz	9.8m/s ² (1g)			-	-
		Continuous vibration				Frequency	Acceleration
5 ≤ f < 9Hz	-	1.75mm	-				
9 ≤ f ≤ 150Hz	4.9m/s ² (0.5g)	-	-				

3 Applicable Version

For system configuration, the following version is necessary.

- XP-Runtime/XP-Builder: V2.10 above

4 Accessory

Check the battery attached in the XGT Panel.

- Use : Reserve backup data and RTC when power off
- Standard : CR2032

Check the mounting Brackets in the box

- Bracket Quantity : 1 set(iXP2-08: 8ea, iXP2-10: 10ea, iXP2-12/15: 12ea)

5 Parts Name and Dimension

This is appearance of the iXP. Refer to each name when driving the system. For more information, refer to user manual.

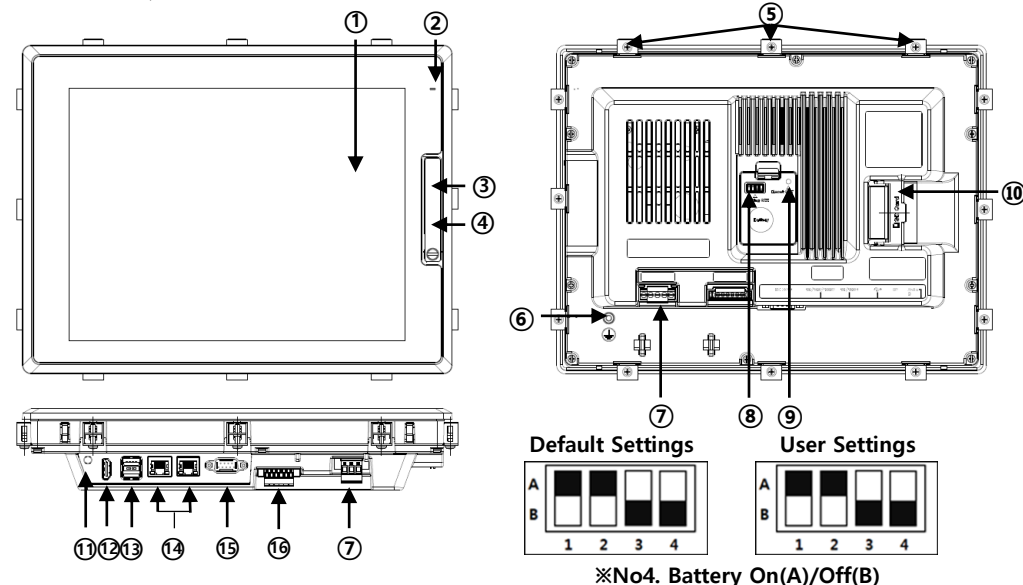

- | | | |
|-----------------------|-----------------------|--------------------|
| ① Front Part | ② Status LED | ③ USB Device |
| ④ USB Host | ⑤ Insertion Slots | ⑥ PE |
| ⑦ Power Terminal | ⑧ Dip Switch Settings | ⑨ Reset Switch |
| ⑩ SD card Interface | ⑪ Audio out | ⑫ HDMI out |
| ⑬ USB Host | ⑭ Ethernet Terminal | ⑮ RS-232C Terminal |
| ⑯ RS-422/485 Terminal | | |

Dimension

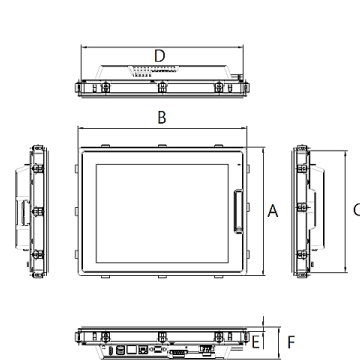

[Unit: mm]

Item	iXP2-08	iXP2-10	iXP2-12	iXP2-15
A	180.0	212.0	239.0	294.0
B	240.0	270.0	313.0	395.0
C	158.0	200.0	227.0	282.0
D	228.0	258.0	301.0	383.0
E	8.0	8.0	8.0	8.0
F	59.7	59.7	59.7	65.5

6 Installation

When you install the XGT Panel, a panel, designed to mount the XGT Panel inside should be specified and allowed for.

1) Panel Cut Dimensions

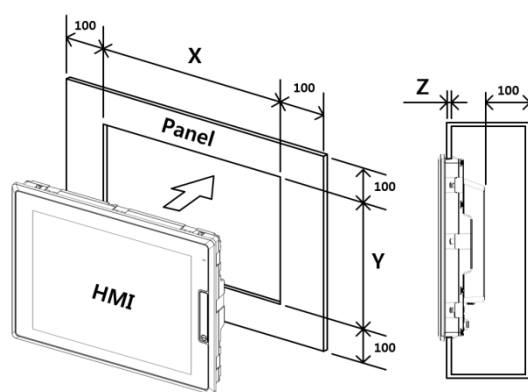

[Unit: mm]

Item	Dimension		Tolerance	
	X	Y		
iXP2-08	228.5	158.5	+	1
			-	0
iXP2-10	259.0	201.0	+	1
			-	0
iXP2-12	301.5	227.5	+	1
			-	0
iXP2-15	383.5	282.5	+	1
			-	0

2) Mounting XGT Panel

- Ensure that there is 100mm clearance around all sides of the panel to be affected at a minimum by the electromagnetic wave or heat.
- The panel thickness (Z) should be 1.6 ~ 6mm.
- Insert the mounting brackets into the XGT Panel insertion slots. Tightening the screws with too much force can damage the product. (The recommend torque is 6.7kgf·cm)
- Use screwdriver to tighten brackets screw as illustration shown.

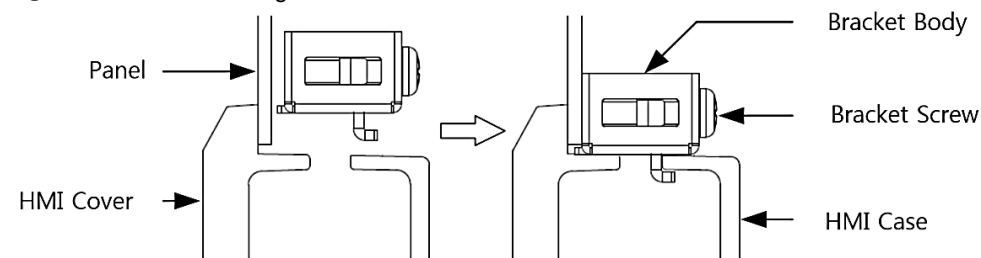

7 Wiring

Power wiring

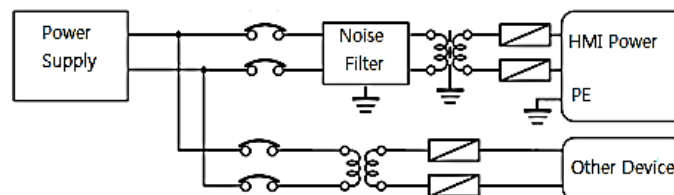

Item	iXP2-08□□/10□□/12□□/15□□A	iXP2-08□□/10□□/12□□/15□□D
Rated voltage	AC100~240V(50/60Hz)	DC24V

- In case that the power is out of rated voltage, connect constant voltage transformer.
- Connect the power having the small noise between cables or between earths. In case of having lots of noise, connect the insulation transformer or noise filter.
- Separate the XGT Panel mains from other equipment (high voltage and current). And communication cable should be separated from the power cable by 100mm or more.
- Use the power supply and earthing wire within the range 18AWG ~ 22AWG.
- Ground resistance should be less than 100Ω. Recommended to use a earthing wire with cross sectional area greater than 2mm². If it malfunctions, remove the earthing.

8 Warranty

Warranty period

LS ELECTRIC provides an 18-month-warranty from the date of the production.

Scope of Warranty

- The troubles caused by improper condition, environment or treatment except the instructions of LS ELECTRIC.
- The troubles caused by external devices.
- The troubles caused by remodeling or repairing based on the user's own discretion.
- The troubles caused by improper usage of the product.
- The troubles caused by the reason which exceeded the expectation from science and technology level when LS ELECTRIC manufactured the product.
- The troubles caused by natural disaster.

LS ELECTRIC Co., Ltd www.lselectric.co.kr 10310001653, V1.1 (2020.04)

E-mail: automation@lselectric.co.kr



- | | |
|----------------------------------------------------|-------------------------------|
| • Headquarter/Seoul Office | Tel: 82-2-2034-4033,4888,4703 |
| • LS ELECTRIC Shanghai Office (China) | Tel: 86-21-5237-9977 |
| • LS ELECTRIC (Wuxi) Co., Ltd. (Wuxi, China) | Tel: 86-510-6851-6666 |
| • LS-ELECTRIC Vietnam Co., Ltd. (Hanoi, Vietnam) | Tel: 84-93-631-4099 |
| • LS ELECTRIC Middle East FZE (Dubai, U.A.E.) | Tel: 971-4-886-5360 |
| • LS ELECTRIC Europe B.V. (Hoofddorf, Netherlands) | Tel: 31-20-654-1424 |
| • LS ELECTRIC Japan Co., Ltd. (Tokyo, Japan) | Tel: 81-3-6268-8241 |
| • LS ELECTRIC America Inc. (Chicago, USA) | Tel: 1-800-891-2941 |

• Factory: 56, Samseong 4-gil, Mokcheon-eup, Dongnam-gu, Cheonan-si, Chungcheongnam-do, 31226, Korea