

COMBITRON are supply and actuator modules for the electromagnet clutches and brakes. As power supply for DC- or AC-side switching different single-wave and bridge rectifiers as well as rapid switchgear of the series **COMBITRON** are available.

The rectifiers correspond to the low voltage regulation 73/231/EWG of the European Union.

COMBITRON Rectifiers and Switches

Half-wave and bridge rectifiers from	0 ... 720 V AC	page 44	COMBITRON 91
Electronic rapid switch up to	50 W	page 46	COMBITRON 94
Rapid-switching rectifier (for COMBISTOP)		page 47	COMBITRON 98

Technical Data

Switching mode (AC- / DC-side switching)	page 48
--	---------





COMBITRON 91 are **rectifiers** for power supply of brakes and clutches. AC voltage supply max 720 V AC for AC or DC side switching conform to the low voltage regulation 72/231 EWG of the European Union.

Harmful electromagnetic interferences arise at the switching of electromagnetic clutches and brakes and other inductive DC consumers.

The half-wave rectifier 0291010-CEMV limits these interferences to class A according to EN 55011.

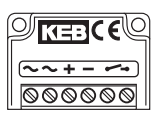
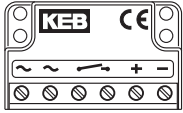
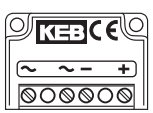
All other rectifiers are not equipped with measurements to suppress radio interference. This has to be taken into consideration for the planning of the interference suppression of the plant or the machine. The user is responsible for meeting the EU machine directive.

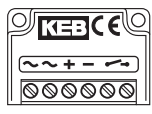
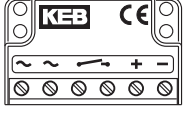
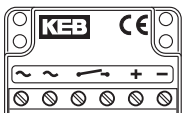
U_{in} switching U_{vmax}	275 V AC +0% AC/DC 450 V	500 V AC +0% AC/DC 900 V	600 V AC +0% AC 1000 V	720 V AC +0% AC 1600 V
half wave ⁴⁾ $U_{out} = 0,45 * U_{in}$ $I_N (45^\circ C) = 1,0A$ $I_N (80^\circ C) = 0,5A$	0291010-CE07 ²⁾ 	0491010-CE07 ³⁾ 	0591010-CE09 ²⁾ 	0691010-CE09 ³⁾ 
full wave ⁴⁾ $U_{out} = 0,9 * U_{in}$ $I_N (45^\circ C) = 2,0A$ $I_N (80^\circ C) = 1,0A$	0291020-CE07 ²⁾ 	0491020-CE07 ³⁾ 	U_{in} maximum input voltage U_{vmax} maximum cut-off voltage U_{out} Output DC voltage AC AC switching DC DC-side switching $I_N (45^\circ C)$ Rated output current at the temperature	
half wave with EMC protection ¹⁾ $U_{out} = 0,45 * U_{in}$ $I_N (45^\circ C) = 1,0A$ $I_N (80^\circ C) = 0,5A$	0291010-CEMV ³⁾ 	Characteristics <ul style="list-style-type: none"> • UL - certification (No.: E.308765) • compact design in a plastic housing • possible installation into the motor terminal box • protection against voltage peaks of the switching contacts • maximal ambient temperature 80 °C 		

¹⁾ with internal interference suppression according to EN 55011/ class A
²⁾ picture 1 ³⁾ picture 2
⁴⁾ different values (U, A) when used under UL conditions

Nominal voltage magnet	Coil voltage tolerance $U_2 (U_{out})$	AC voltage supply $U_1 (U_{in})$	Type of rectifier	
24 V DC				
105 V DC	93 - 118	230 V AC	half wave rectifier	(0291010-CE07)
205 V DC	182 - 230	230 V AC	full wave rectifier	(0291020-CE07)
180 V DC	162 - 198	400 V AC	half wave rectifier	(0491010-CE07)

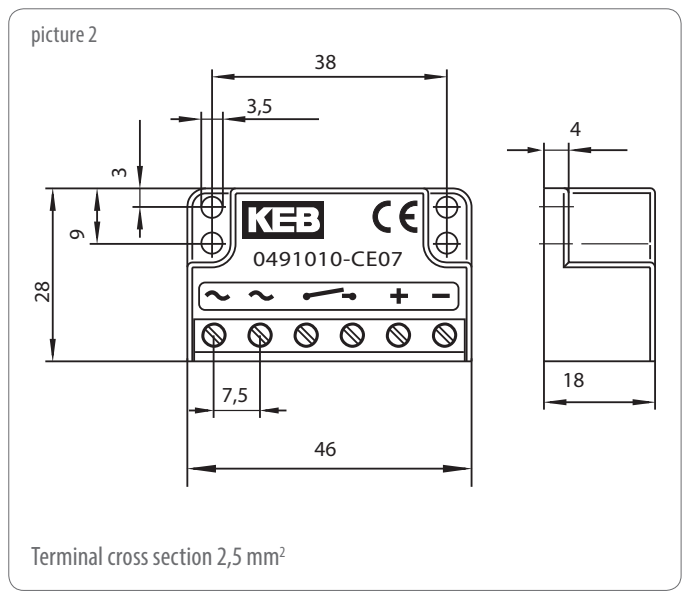
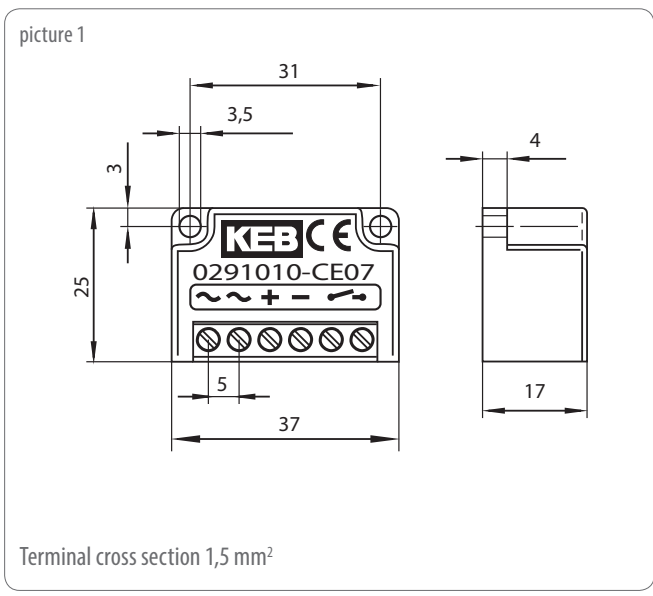

COMBITRON 94 for the power supply / actuator of two consumers.

The output current control ensures a constant magnetic flux and permits short-time overexcitations for shorter switching processes, i.e. improved repeat accuracy. The main field of application is the interconnection of clutch-brake-combinations **COMBIBOX** and is used whenever high switching frequencies and positioning accuracy are demanded. The primary feature is the current regulation of 24 V DC supply of electromagnets.

Eigenschaften

- circuit board is supplied inclusive holder and slide-in device
- connection according to DIN 41612
- Vadjustment of the deceleration time by potentiometer from 0 ... 1 second
- power supply of the circuit board via separate transformer
input voltage: 230/400/460 V AC
- power range 15 ... 50 W
- digital inputs
- relay output



transformer 0094006-0100



switcher 0094006-0004

COMBITRON 98 rapid-switching rectifiers with overexcitation for optimal turn-on and turn-off times of spring-applied brakes and electromagnets.

Two Powerbox versions with similar right housing to fit on DIN rail or bolt on version.

COMBITRON 9098200-CE09 UL - certification (No.: E.308765)



	9098210-CE04	9098200-CE09 ¹⁾
Input voltage	24 V DC $\pm 20\%$	180-300 V AC $\pm 0\%$
Overexcitation time	800 ms $\pm 15\%$	350 ms $\pm 10\%$
Cable length	max. 10 m to brake coil	max. 100 m to brake coil
Current I _N 45 °C	1.2 A continuous 7 A for 800 ms	1.2 A continuous 2.4 A for 350 ms
Current I _N 75 °C	0.6 A continuous 3.5 A for 800 ms	0.7 A continuous 1.4 A for 350 ms
Temperature	CCV -40° ... 75°	CCV -40° ... 75°
Switching rate	max. 6 per minute at max current	max. 1 per minute at max current
Side altitude above sea level	> 1,000 m - 1 % current reduction/100 m	> 1,000 m - 1 % current reduction/100 m
Wiring diagrams		

¹⁾ different values (U, A) when used under conditions of UL

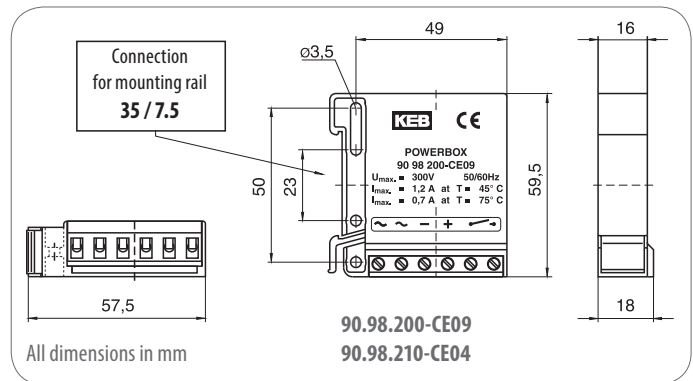

AC-side Switching

When switching before the rectifier on the AC-side the magnetic field decays slowly. At this mode of switching the tripping delay is quite long. The AC-side switching requires no protective measurements for the coil and the switching contacts. On disconnection the rectifier diodes act as free-wheeling diodes.

The switching times t_{11} for AC-side switching increase when the rectifier is connected directly in the motor terminal box **(2)**. When the motor slows down a generatoric voltage is applied to the motor terminals. The wiring **(2 and 3)** is not permitted for frequency inverter operation.

For line lengths of more than 10 m between rectifier and brake at AC-side switching the regulations prescribe the use of a separate switch **(1)**. In this case the supply voltage may not be tapped behind the motor contactor **(2)**. If it is not possible to install an additional switch the use of special rectifiers becomes necessary.

Current-time-/Voltage-time-/Torque-time-diagram

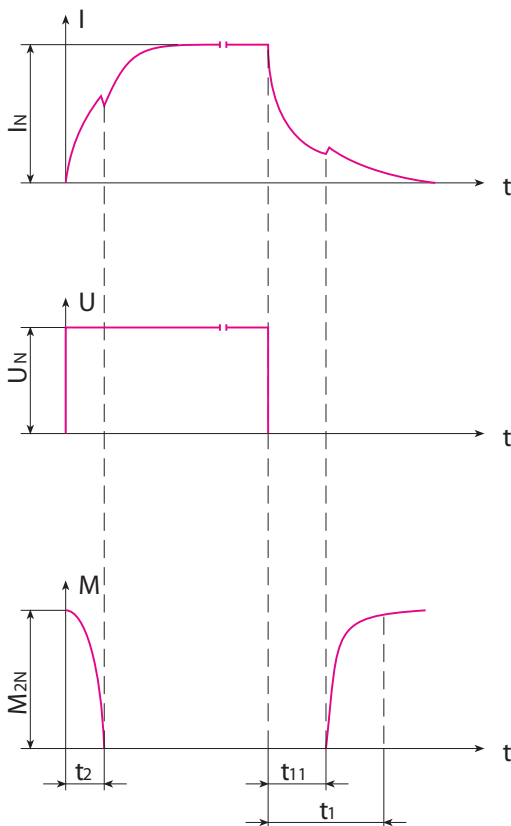

t_1 = Engagement time
 t_{11} = Engagement delay time
 t_2 = Release time

Wiring diagram

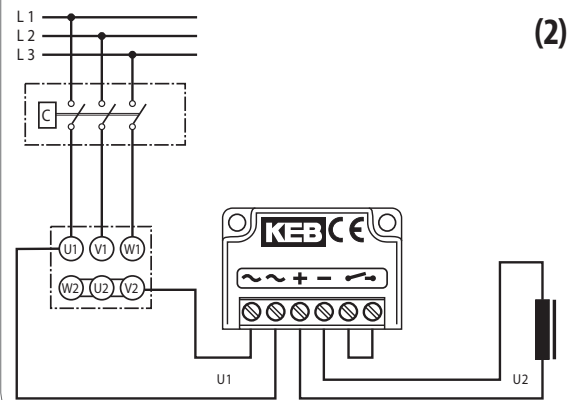
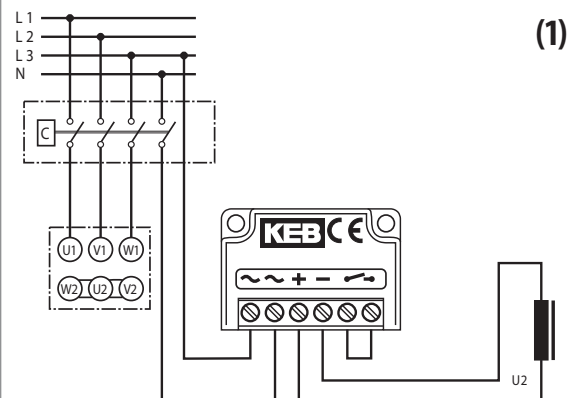

DC-side switching

The switching is done between the rectifier and the magnet. At his mode of switching the tripping delay is short, since the energy of the magnetic field is absorbed by the rectifier. The voltage peaks that occur at switching are limited to a harmless level for the rectifier.

The maximal permissible switching frequency for the DC-side switching of rectifiers depends on the energy content of the magnet for **COMBISTOP**. Higher switching frequencies are achieved by the external connection of a varistor in parallel to the brake or to the terminals + and - DC of the rectifier.

Rectifier	KEB-article	varistor
0291	0090045-2753	S20K275
0491	0090045-6251	S20K625
0591	0090045-6251	S20K625

Current-time-/Voltage-time/
Torque-time- diagram

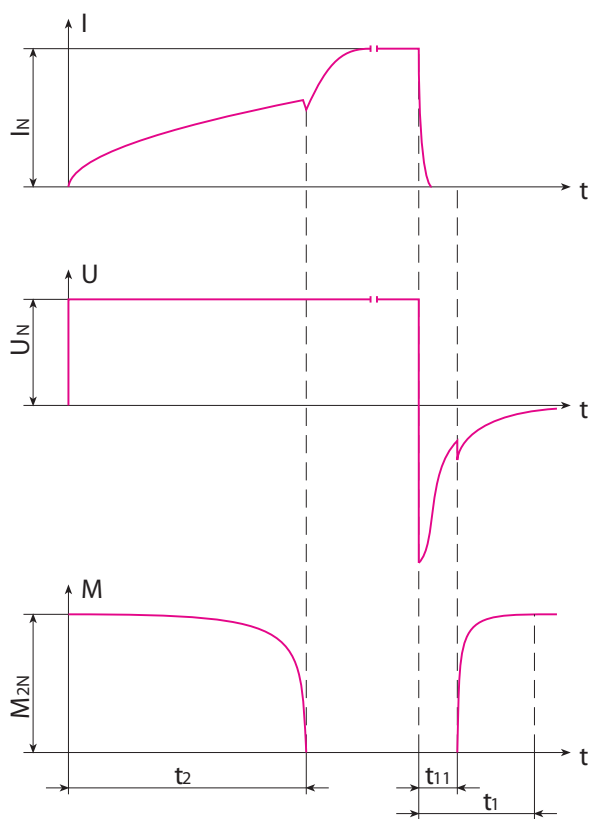

Wiring diagram

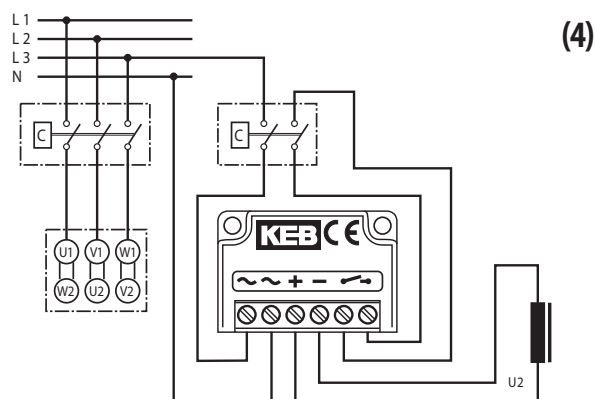
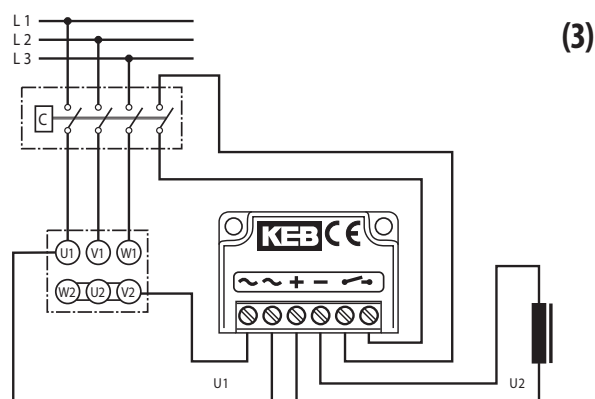

The simultaneous AC and DC-side switching, shown in example 4 guarantees short disconnecting times and reduces the contact erosion.