

# MicroSmart FC6A PLC

## CPU Module Specifications



### KEY FEATURES

- Embedded Ethernet port
- Embedded SD memory port
- Modbus TCP and RTU
- Embedded RS232C/RS485 user selectable
- Maximum 520 digital I/O
- Maximum 126 analog I/O
- Data Logging
- Web Server Functions
- Large programming and data memory
- CAN J1939 CPU
- Built-in Web Page Editor for user webpage

### Standard Base Module

Part Number	Total I/O	Power Voltage	Input Voltage	Output Type	Maximum Digital I/O	Maximum Analog I/O			
FC6A-C16R1AE	16 (9 inputs, 7 outputs)	100-240V AC	24V DC Sink/Source	Relay	400	100			
FC6A-C16R1CE		24V DC		Relay					
FC6A-C16P1CE				Transistor Source					
FC6A-C16K1CE		Transistor Sink							
FC6A-C24R1AE	24 (14 inputs, 10 outputs)	100-240V AC	24V DC Sink/Source	Relay	504	124			
FC6A-C24R1CE		24V DC		Relay					
FC6A-C24P1CE				Transistor Source					
FC6A-C24K1CE		Transistor Sink							
FC6A-C40R1AE	40 (24 inputs, 16 outputs)	100-240V AC	24V DC Sink/Source	Relay	520	126			
FC6A-C40R1CE		24V DC		Relay					
FC6A-C40P1CE				Transistor Source					
FC6A-C40K1CE		Transistor Sink							
FC6A-C40R1DE		12V DC		12V DC Sink/Source			Relay	40	6
FC6A-C40P1DE							Transistor Source		
FC6A-C40K1DE	Transistor Sink								

### CAN J1939 Base Module

Part Number	Total I/O	Power Voltage	Input Voltage	Output Type	Maximum Digital I/O	Maximum Analog I/O
FC6A-C40R1AEJ	40 (24 inputs, 16 outputs)	100-240V AC	24V DC Sink/Source	Relay	520	126
FC6A-C40R1CEJ		24V DC		Relay		
FC6A-C40P1CEJ				Transistor Source		
FC6A-C40K1CEJ		Transistor Sink				
FC6A-C40R1DEJ	12V DC	12V DC Sink/Source	Relay	40	6	
FC6A-C40P1DEJ			Transistor Source			
FC6A-C40K1DEJ			Transistor Sink			

# SPECIFICATIONS

Part Number	FC6A-C16R1AE FC6A-C16R1CE FC6A-C16P1CE FC6A-C16K1CE	FC6A-C24R1AE FC6A-C24R1CE FC6A-C24P1CE FC6A-C24K1CE	FC6A-C40R1AE FC6A-C40R1CE FC6A-C40P1CE FC6A-C40K1CE FC6A-C40R1DE FC6A-C40P1DE FC6A-C40K1DE	FC6A-C40R1AEJ FC6A-C40R1CEJ FC6A-C40P1CEJ FC6A-C40K1CEJ FC6A-C40R1DEJ FC6A-C40P1DEJ FC6A-C40K1DEJ
Rated Power Voltage	AC: 100 to 240V AC, DC: 24V DC, 12V DC			
Allowable Voltage Range	AC: 85 to 264V AC 24V DC: 20.4 to 28.8V DC (including ripple), 12V DC: 10.2 to 18.0V			
Rated Frequency	AC: 50/60Hz (47 to 63 Hz)			
Maximum Power Consumption (CPU module)	AC	FC6A-C16R1AE: 100-240V AC, 33VA FC6A-C24R1AE: 100-240V AC, 35VA FC6A-C40R1AE: 100-240V AC, 41VA FC6A-C40R1AEJ: 100-240V AC, 37VA		
	DC	FC6A-C16R1CE: 24V DC 140mA, 3.36W FC6A-C24R1CE: 24V DC 155mA, 3.72W FC6A-C40R1CE: 24V DC 195mA, 4.68W FC6A-C16P1CE: 24V DC 190mA, 4.6W FC6A-C24P1CE: 24V DC 200mA, 4.8W FC6A-C40P1CE: 24V DC 205mA, 5.0W	FC6A-C16K1CE: 24V DC 190mA, 4.6W FC6A-C24K1CE: 24V DC 200mA, 4.8W FC6A-C40K1CE: 24V DC 205mA, 5.0W FC6A-C40R1DE: 12V DC 345mA, 4.14W FC6A-C40P1DE: 12V DC 260mA, 3.12W FC6A-C40K1DE: 12V DC 260mA, 3.12W	FC6A-C40R1CEJ: 24V DC 205mA, 5.0W FC6A-C40P1CEJ: 24V DC 175mA, 4.2W FC6A-C40K1CEJ: 24V DC 175mA, 4.2W FC6A-C40R1DEJ: 12V DC 340mA, 4.08W FC6A-C40P1DEJ: 12V DC 320mA, 3.9W FC6A-C40K1DEJ: 12V DC 320mA, 3.9W
Allowable Momentary Power Interruption	10 ms (at rated voltage)			
Dielectric Strength	Between power and ground terminals: 1,500V AC, 1 minute Between I/O and ground terminals: 1,500V AC, 1 minute			
Insulation Resistance	Between power and ground terminals: 100 MΩ minimum (500V DC megger) Between I/O and ground terminals: 100 MΩ minimum (500V DC megger)			
Noise Resistance	AC or DC power terminal: 1.5kV (DC type: 1kV), 50 ns to 1 μs I/O terminals (coupling clamp): 1.5kV, 50ns to 1μs coupling adapter			
Inrush Current	AC: 40A maximum 24V DC: 35A maximum 12V DC: 35A maximum			
Power Supply Wire	AWG22, AWG18			
Operating Temperature	-10 to +55°C (no freezing)			
Storage Temperature	-25 to +70°C (no freezing)			
Relative Humidity	Level RH1 (IEC 61131-2-10 to 95% (no condensation)			
Altitude	Operation: 0 to 2,000m, 795 to 1,013hPa, Transport: 0 to 3,000m, 701 to 1,013hPa			
Pollution Degree	2 (IEC 60664-1)			
Corrosion Immunity	Free from corrosive gases			
Degree of Protection	IP20 (IEC 60529)			
Ground	D-type ground (Class 3 ground)			
Grounding Wire	AWG16			
Vibration Resistance	5 to 8.4 Hz amplitude 3.5 mm, 8.4 to 150 Hz acceleration 9.8 m/s <sup>2</sup> (1G), 2 hours per axis on each of three mutually perpendicular axes (IEC 61131-2)			
Shock Resistance	147 m/s <sup>2</sup> (15G), 11 ms duration, 3 shocks per axis on three mutually perpendicular axes			
Mounting	DIN rail or panel mounting			
Weight	AC: 350g DC: 340g	AC: 420g DC: 400g	AC: 560g DC (relay): 530g DC (transistor): 480g	AC: 560g DC (relay/24V DC): 530g DC (relay/12V DC): 560g DC (transistor/24V DC): 480g DC (transistor/12V DC): 530g

**SPECIFICATIONS CONT.**

Part Number		FC6A-C16R1AE FC6A-C16R1CE FC6A-C16P1CE FC6A-C16K1CE	FC6A-C24R1AE FC6A-C24R1CE FC6A-C24P1CE FC6A-C24K1CE	FC6A-C40R1AE FC6A-C40R1CE FC6A-C40P1CE FC6A-C40K1CE FC6A-C40R1DE FC6A-C40P1DE FC6A-C40K1DE	FC6A-C40R1AEJ FC6A-C40R1CEJ FC6A-C40P1CEJ FC6A-C40K1CEJ FC6A-C40R1DEJ FC6A-C40P1DEJ FC6A-C40K1DEJ
Control System		Stored program system			
Instruction Words	Basic	42			
	Advanced	124			
Program Capacity <sup>1</sup>		384KB (48,000 steps)/72KB (9,000 steps) <sup>2</sup>		640KB (80,000) 72KB (9,000 steps) <sup>2</sup>	
User Program Storage		Serial Flash Memory (100,000 times rewritable)			
Processing Time	Basic Instruction	42us/1,000 steps			
	END Processing <sup>3</sup>	1ms maximum			
I/O Points	Input	9 points	14 points	24 points	
	Output	7 points	10 points	16 points	
Expandable Modules		4 modules		7 modules	
Expandable I/O Points with Expansion Modules		128 points		224 points	
Expandable Modules with Expansion Interface Modules		8 modules			
Expandable I/O Points with Expansion Interface Modules		256 points			
Internal Relay		12,400 points			
Special Internal Relay		256 points			
Shift Register		256 points			
Data Register		54,000 points			
Special Data Register		500 points			
Counter		512 points			
Timer (1ms, 10ms, 100ms, 1s)		1,024 points			
Clock		Clock accuracy: ±30 sec/month (typical) at 25°C			
RAM Backup	Backup Data	Internal relay, shift register, counter, data register, timer, special data register, special internal relay			
	Battery	Lithium primary battery (BR2032)			
	Battery Life	Approx. 4 years			
	Replaceability	Possible			
Self-diagnostic Function		Keep data, user program sum check (EEPROM), user program sum check (RAM), timer/counter preset value sum check, user program syntax check, user program execution check, WDT check, user program write check, power failure, clock error, data link connection check, I/O bus initialization check			
Input Filter		0 ms (without filter), 3 to 15ms (selectable in increments of 1ms)			
Catch Input/Interrupt Input		Six inputs I0, I1, I6, I7 Minimum turn on pulse width: 5µs max. Minimum turn off pulse width: 5µs max.		I3, I4 Minimum turn on pulse width: 35µs max. Minimum turn off pulse width: 35µs max.	
High-speed Counter	Maximum Counting Frequency and High-speed Counter Points	Total 6 points Single/two-phase selectable: 100 kHz (single-phase: 4 points, two-phase: 2 points) Single-phase: 5 kHz (2 points)			
	Counting Range	0 to 4,294,967,295 (32 bits)			
	Operation Mode	Rotary encoder mode, adding counter mode, frequency measurement mode			
Analog Potentiometer	Quantity	1 point		-	
	Data Range	0 to 1,000		-	
Analog Voltage Input	Quantity	1 point		-	
	Input Voltage Range	0 to 10V		-	
	Input Impedance	Approx. 100KΩ		-	
	Digital Resolution	Approx. 1,000 steps (10 bits)		-	
Pulse Output	Quantity	4 points		-	
	Maximum Frequency	High speed output port: 100 kHz (2 points) maximum Middle speed output port: 5 kHz (2 points maximum)		High speed output port: 100 kHz maximum	
External Power Supply for Sensor (AC only)	Output Voltage/Current	24V (+10%, -15%) / 250mA			
	Overload Detection	Impossible			
	Isolation from the internal circuit	Transformer-isolated			
USB Port		USB mini-B (maintenance communication)			
Serial Port 1, CAN Port		RS232C or RS485 <sup>4</sup>		CAN J1939	
Ethernet Port 1		Ethernet (maintenance communication, user communication, user communication, Modbus TCP server/client)			
SD Card Slot		Embedded			
Cartridge (option)		One cartridge can be added		Two cartridges can be added	
HMI Module (option)		Yes	Yes	Yes	Yes

Note: The maximum number of relay outputs that can be turned on simultaneously is limited.

Note 1: 1 step equals 8 bytes.

Note 2: When 72KB is selected, download function can be used during RUN.

Note 3: Not including expansion I/O service time, counter timer processing time, data link processing time, and interrupt processing time.

Note 4: Maintenance communication, user communication, data link, Modbus RTU master/slave communication.

## USB Port Specifications

Part Number	FC6A-C16R1AE FC6A-C16R1CE FC6A-C16P1CE FC6A-C16K1CE	FC6A-C24R1AE FC6A-C24R1CE FC6A-C24P1CE FC6A-C24K1CE	FC6A-C40R1AE FC6A-C40R1CE FC6A-C40P1CE FC6A-C40K1CE FC6A-C40R1DE FC6A-C40P1DE FC6A-C40K1DE	FC6A-C40R1AEJ FC6A-C40R1CEJ FC6A-C40P1CEJ FC6A-C40K1CEJ FC6A-C40R1DEJ FC6A-C40P1DEJ FC6A-C40K1DEJ
USB Type	USB mini-B			
USB Standard	USB 2.0 full speed			
Isolation	Not isolated from the internal circuit			
Communication Function	Maintenance communication to PC			

## Ethernet Port 1 Specifications

Part Number	FC6A-C16R1AE FC6A-C16R1CE FC6A-C16P1CE FC6A-C16K1CE	FC6A-C24R1AE FC6A-C24R1CE FC6A-C24P1CE FC6A-C24K1CE	FC6A-C40R1AE FC6A-C40R1CE FC6A-C40P1CE FC6A-C40K1CE FC6A-C40R1DE FC6A-C40P1DE FC6A-C40K1DE	FC6A-C40R1AEJ FC6A-C40R1CEJ FC6A-C40P1CEJ FC6A-C40K1CEJ FC6A-C40R1DEJ FC6A-C40P1DEJ FC6A-C40K1DEJ
Communication Type	IEEE802.3 compliant			
Data Transfer	10BASE-T, 100BASE-TX			
Connector	RJ45			
Cable	CAT.5STP			
Maximum Cable Length	100m			
Isolation	Pulse trans isolation			
Communication Function	Maintenance communication server, user communication server, Modbus TCP (server/client), PING, SNTP			

## Serial Port 1, CAN Port Specifications

Part Number	FC6A-C16R1AE FC6A-C16R1CE FC6A-C16P1CE FC6A-C16K1CE	FC6A-C24R1AE FC6A-C24R1CE FC6A-C24P1CE FC6A-C24K1CE	FC6A-C40R1AE FC6A-C40R1CE FC6A-C40P1CE FC6A-C40K1CE FC6A-C40R1DE FC6A-C40P1DE FC6A-C40K1DE	FC6A-C40R1AEJ FC6A-C40R1CEJ FC6A-C40P1CEJ FC6A-C40K1CEJ FC6A-C40R1DEJ FC6A-C40P1DEJ FC6A-C40K1DEJ
Port Type	Serial port 1			CAN port
Communication Type	RS232C or RS485 selectable			CAN
Connector	RJ45			Terminal Block (5-pole)
Cable	CAT.5STP			SAE J1939-11/SAE J1939-15
Maximum Baud Rate Maximum Cable Length	115,200bps RS232C: 5m, RS485: 200m			SAE J1939-11: 250bps: 40m, stubs, 1m maximum SAE J1939-15: 250bps: 40m, stubs, 3m maximum
Isolation	Not isolated from the internal circuit			Isolated from the internal circuit
Communication Function	Maintenance communication, user communication, Modbus RTU (master/slave)			J1939

## CAN J1939 Specifications

Part Number	FC6A-C40P1CEJ FC6A-C40K1CEJ FC6A-C40P1DEJ FC6A-C40K1DEJ	FC6A-C40R1AEJ FC6A-C40R1CEJ FC6A-C40R1DEJ	
Supported SAE J1939	SAE J1939-11: Physical Layer, 250K bits/s, Twisted Shielded Pair SAE J1939-15: Reduced Physical Layer, 250K bits/s, Unshielded Twisted Pair SAE J1939-21: Data Link Layer SAE J1939-71: Vehicle Application Layer SAE J1939-73: Application Layer - Diagnostics SAE J1939-75: Application Layer - Generator Sets and Industrial SAE J1939-81: Network Management		
Transmit/Receive Message	Maximum No. of Send Message	100	
	Maximum No. of Receive Message	200	
	Transmittable PGN	Optional	
	Maximum Length of Transmit/Receive Message	1 to 252 bytes/message	
Transmission Function	Transmission Type	Event transmission/periodical transmission	
	Event Transmission	Transmission Method	Internal relay
	Cycle Transmission	Transmission Method Transmission Cycle <sup>1</sup>	Internal relay 10 to 655,350 ms (in increments of 10ms)
Receive Function	Receive Method	Polling reception <sup>2</sup>	
	Receive Cycle Monitor	0, 10 to 655,350 ms (disabled at 0)	
Request Function	Yes		
Network Management Function	Static address/dynamic address management		
	NAME	Optional (automatic switching of static address/dynamic address management at highest-order bit)	
	Number of Nodes Manageable	128 nodes	
PGNs used Internally	00EA00h: Request PGN		
	00E800h: Acknowledgement		
	00EB00h: TP.DT		
	00EC00h: TP.CM		
	00EE00h: Address claim		

Note 1: Message is transmitted in END processing. Actual transmission cycle is affected by the ladder execution cycle.

Note 2: Receive message is transferred from internal buffer to data register in END processing.

## Input Specifications

Part Number	FC6A-C16R1AE FC6A-C16R1CE FC6A-C16P1CE FC6A-C16K1CE	FC6A-C24R1AE FC6A-C24R1CE FC6A-C24P1CE FC6A-C24K1CE	FC6A-C40R1AE FC6A-C40R1CE FC6A-C40P1CE FC6A-C40K1CE FC6A-C40R1DE FC6A-C40P1DE FC6A-C40K1DE	FC6A-C40R1AEJ FC6A-C40R1CEJ FC6A-C40P1CEJ FC6A-C40K1CEJ FC6A-C40R1DEJ FC6A-C40P1DEJ FC6A-C40K1DEJ
Input Points	9 (9/1 common)	14 (14/1 common)	24 (24/1 common)	
Rated Input Voltage	AC, 24V DC: 24V DC sink/source input signal 12V DC: 12V DC sink/source input signal			
Input Voltage Range	AC, 24V DC: 0 to 28.8V DC 12V DC: 0 to 18.0V DC			
Rated Input Current	AC, 24V DC: high speed input port: 5mA/pt, middle/normal speed input port 7mA/pt 12V DC: high speed input port: 5mA/pt, middle/normal speed input port 6mA/pt			
Input Impedance	AC, 24V DC: high speed input port: 4.9kΩ, middle/normal speed input port: 3.4kΩ 12V DC: high speed input port: 1.8kΩ, middle/normal speed input port: 2.0kΩ			
Turn ON Time	High-speed input port: 5μs + filter value Middle-speed input port: 35μs + filter value Normal-speed input port: 35μs + filter value			
Turn OFF Time	High-speed input port: 5us + filter value Middle-speed input port: 35us + filter value Normal-speed input port: 100us + filter value			
Isolation	Between input terminals: Not isolated Internal circuit: Photocoupler-isolated			
Input Type	Type1 (IEC 61131-2)			
External Load for I/O Interconnection	Not needed			
Signal Determination Method	Static			
Effect of Improper Input Connection	Both sinking and sourcing input signals can be connected, therefore reverse connection does not cause damage. If any input exceeding the rated value is applied, permanent damage may be caused.			
Cable Length	3m in compliance with electromagnetic immunity			
Connector	Insertion Durability	100 times minimum		
	Applicable Ferrule	1-wire: AI 0.5-8 WH (Phoenix Contact) 2-wire: AI-TWIN 2×0.5-8 WH (Phoenix Contact)		

## Transistor Output Specifications

Part Number	FC6A-C16P1CE FC6A-C16K1CE	FC6A-C24P1CE FC6A-C24K1CE	FC6A-C40P1CE FC6A-C40K1CE FC6A-C40P1DE FC6A-C40K1DE	FC6A-C40P1CEJ FC6A-C40K1CEJ FC6A-C40P1DEJ FC6A-C40K1DEJ
Transistor Output Points	7 (7/1 common)	10 (10/1 common)	16 (8/1 common)	
Output Type	Transistor Sink	FC6A-C16K1CE/FC6A-C24K1CE/FC6A-C40K1CE/FC6A-C40K1DE/FC6A-C40K1CEJ/FC6A-C40K1DEJ		
	Transistor Source	FC6A-C16P1CE/FC6A-C24P1CE/FC6A-C40P1CE/FC6A-C40P1DE/FC6A-C40P1CEJ/FC6A-C40P1DEJ		
Rated Load Voltage	24V DC: 24V DC 12V DC: 12V DC			
Voltage Tolerance	24V DC: 19.2 to 28.8V DC 12V DC: 10.2 to 18.0V DC		24V DC: 19.2 to 28.8V DC 12V DC: 10.2 to 16.0V DC	
Rated Load Current	Per Point	0.5A		
	Per Common	3.5A	5A	4A
Voltage Drop (ON Voltage)	1V max (voltage between COM and output terminal when output is on.)			
Inrush Current	1A			
Leakage Current	0.1mA maximum			
Clamping Voltage	24V DC: 39V ±1V 12V DC: 27V ±1V			
Maximum Lamp Load	12W			
Inductive Load	24V DC: L/R=10ms (28.8V DC, 1Hz) 12V DC: FC6A-C40P1DE/FC6A-C40K1DE, L/R=10ms (18.0V DC 1Hz), FC6A-C40P1DEJ/FC6A-C40K1DEJ, L/R=10ms (16.0V DC, 1Hz)			
Overcurrent Protection	Transistor Sink Output: No Transistor Source Output: Overcurrent is detected by current limit resistance. <sup>1</sup>			
External Current Draw	24V DC: 100mA maximum, 24V DC (power voltage at the +V terminal, -V terminal at source) 12V DC: 100mA maximum, 12V DC (power voltage at the +V terminal, -V terminal at source)			
Isolation	Between output terminal and Internal circuit: Photocoupler-isolated Between output terminals: Not isolated			
Connector	Insertion Durability	100 times minimum		
	Applicable Ferrule	1-wire: AI 0.5-8 WH (Phoenix Contact) 2-wire: AI-TWIN 2×0.5-8 WH (Phoenix Contact)		
Output Delay	Turn ON Time	High speed input port: 5μs Middle speed input port: 30μs Normal speed input port: 300μs		High speed input port: 5μs Middle speed input port: 300μs
	Turn OFF Time	High speed input port: 5μs Middle speed input port: 30μs Normal speed input port: 300μs		High speed input port: 5μs Middle speed input port: 300μs

Note 1: This overcurrent signals consist of one signal per 4 point outputs. When microprocessor gets this overcurrent signal by interrupt input, microprocessor turns off 4pt outputs of this category at fixed time (approx. 1 second).

## Relay Output Specifications

Part Number		FC6A-C16R1AE FC6A-C16R1CE	FC6A-C24R1AE FC6A-C24R1CE	FC6A-C40R1AE FC6A-C40R1CE FC6A-C40R1DE	FC6A-C40R1AEJ FC6A-C40R1CEJ FC6A-C40R1DEJ
Relay Output Points		7	10		16
Output Points per Common Line	COM1	4	4		4
	COM2	3	4		4
	COM3	—	2		4
	COM4	—	—		4
Output Type		1NO 2A			
Maximum Load Current	Per Point	COM1: 7A COM2: 6A			
	Per Common	COM1: 7A COM2: 7A	COM1: 7A COM3: 4A	COM1: 7A COM2: 7A	COM3: 7A COM4: 7A
Minimum Switching Load		1mA/5V DC (reference value)			
Initial Contact Resistance		30 mΩ maximum			
Electrical Life		100,000 operations minimum (rated load 1,800 operations/hour)			
Mechanical Life		20,000,000 operations minimum (no load 18,000 operations/hour)			
Rated Load		Resistive load: 240V AC 2A, 30V DC 2A Inductive load: 240V AC 2A (cos $\theta = 0.4$ ), 30V DC 2A (L/R = 7 ms)			
Dielectric Strength		Between output and ground terminals: 1,500V AC, 1 minute Between output terminal and internal circuit: 1,500V AC, 1 minute Between output terminals (COMs): 1,500V AC, 1 minute			
Connector	Insertion/ Removal Durability	100 times minimum			
	Applicable Ferrule	1-wire: AI 0.5-8 WH (Phoenix Contact) 2-wire: AI-TWIN 2×0.5-8 WH (Phoenix Contact)			

## DIMENSIONS (all dimensions are in mm)

FC6A-C16R1AE/FC6A-C16R1CE  
FC6A-C16P1CE/FC6A-C16K1CE

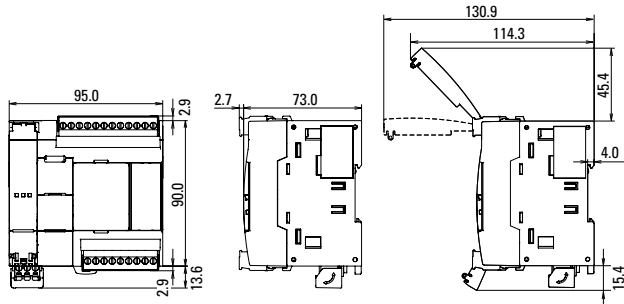

FC6A-C24R1AE/FC6A-C24R1CE  
FC6A-C24P1CE/FC6A-C24K1CE

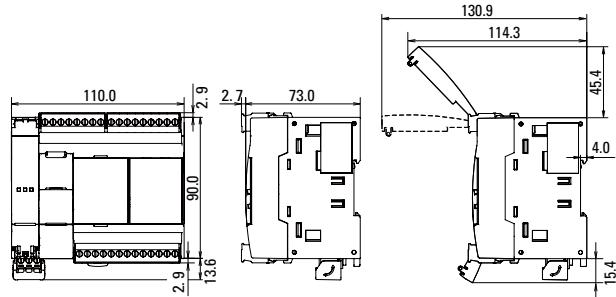

FC6A-C40R1AE/FC6A-C40R1CE  
FC6A-C40P1CE/FC6A-C40K1CE  
FC6A-C40R1DE/FC6A-C40P1DE  
FC6A-C40K1DE

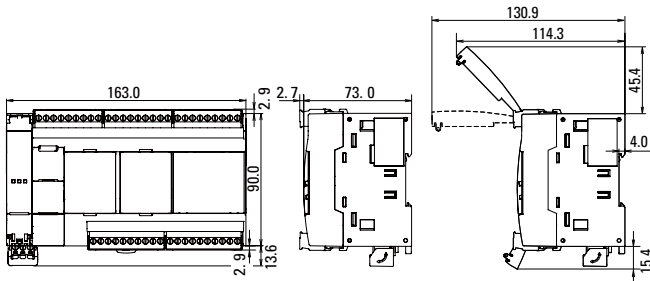

FC6A-C40R1AEJ/FC6A-C40R1CEJ  
FC6A-C40P1CEJ/FC6A-C40K1CEJ  
FC6A-C40R1DEJ/FC6A-C40P1DEJ  
FC6A-C40K1DEJ

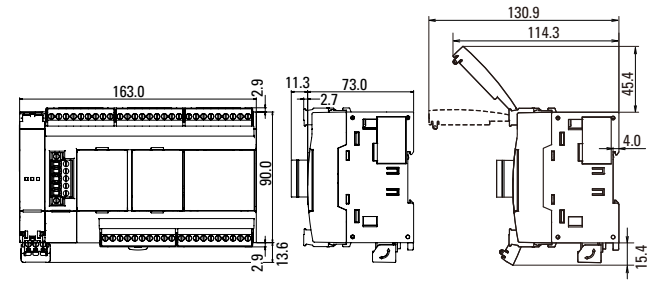

## Temperature derating curves: Input voltage vs. I/O Simultaneous ON Ratio (%)

### Input (with cartridge)

FC6A-C16K1CE FC6A-C40K1DE  
 FC6A-C24K1CE FC6A-C40K1CEJ  
 FC6A-C40K1CE FC6A-C40K1DEJ

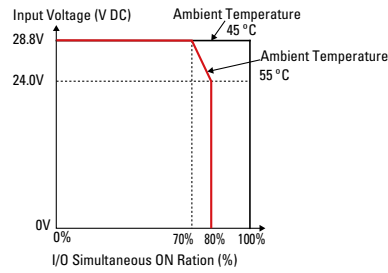

### Output (with cartridge)

FC6A-C16K1CE FC6A-C40K1DE  
 FC6A-C24K1CE FC6A-C40K1CEJ  
 FC6A-C40K1CE FC6A-C40K1DEJ

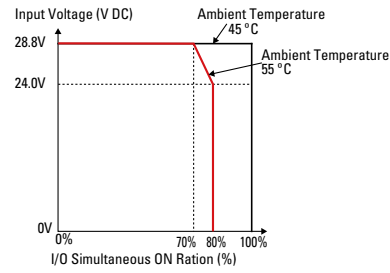

### Input (w/o cartridge)

FC6A-C24P1CE FC6A-C40P1CEJ  
 FC6A-C40P1CE FC6A-C40P1DEJ  
 FC6A-C40P1DE

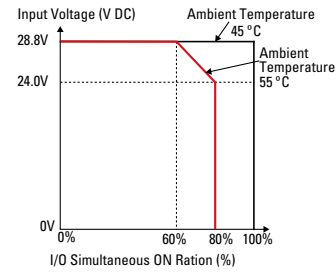

### Output (w/o cartridge)

FC6A-C24P1CE FC6A-C40P1CEJ  
 FC6A-C40P1CE FC6A-C40P1DEJ  
 FC6A-C40P1DE

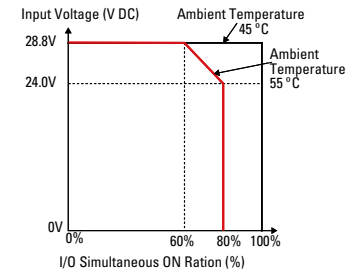

### Input (with cartridge)

FC6A-C24P1CE FC6A-C40P1CEJ  
 FC6A-C40P1CE FC6A-C40P1DEJ  
 FC6A-C40P1DE

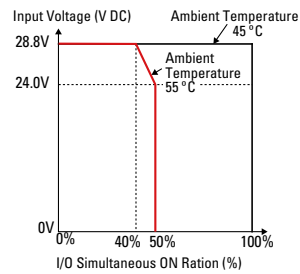

### Output (with cartridge)

FC6A-C24P1CE FC6A-C40P1CEJ  
 FC6A-C40P1CE FC6A-C40P1DEJ  
 FC6A-C40P1DE

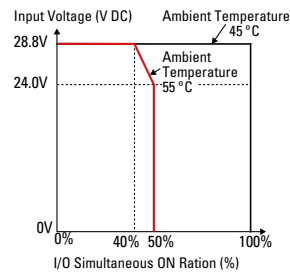

## Input Internal Circuit

100V to 240V AC, 24V DC  
 Transistor Sink Output  
 I0, I1, I6, I7

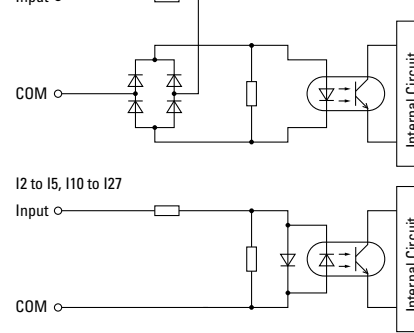

12V DC  
 Transistor Sink Output  
 I0, I1, I6, I7

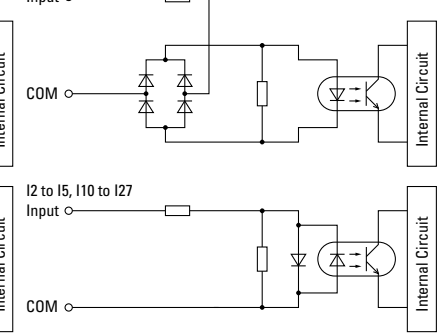

## Output Internal Circuit

100V to 240V AC, 24V DC  
 Transistor Sink Output

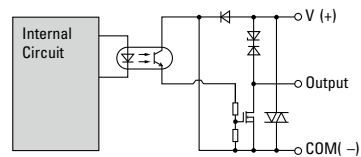

12V DC  
 Transistor Sink Output

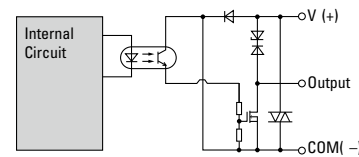

100V to 240V AC, 24V DC  
 Transistor Source Output

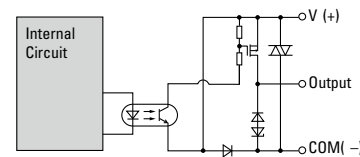

12V DC  
 Transistor Source Output

