

## WJ200 Series Inverter Quick Reference Guide

---

- Single-phase Input 100V class

Manual Number: NT3261X  
July 2011

Refer to the user manual for detail

Hitachi Industrial Equipment Systems Co., Ltd.

## UL® Cautions, Warnings and Instructions

### Warnings and Cautions for Troubleshooting and Maintenance

The warnings and instructions in this section summarize the procedures necessary to ensure an inverter installation complies with Underwriters Laboratories® guidelines.



---

**WARNING:** Use 60/75°C Cu wire only.

---



---

**WARNING:** Suitable for use on a circuit capable of delivering not more than 100,000 rms Symmetrical Amperes, 120V maximum.

---



---

**WARNING:** When protected by J class Fuses, or when Protected by Type E Combination Motor Controller Having An Interrupting Rating Not Less Than 100,000 rms Symmetrical Amperes, 120 Volts Maximum.

---



---

**WARNING:** Install device in pollution degree 2 environment.

---



---

**WARNING:** Maximum Surrounding Air Temperature 45°C (004M), 50°C (007M).

---



---

**WARNING:** Solid state motor overload protection is provided in each model

---



---

**WARNING:** Integral solid state short circuit protection does not provide branch circuit protection. Branch circuit protection must be provided in accordance with the National Electric Code and any additional local codes

---

## Terminal symbols and Screw size

Inverter Model	Screw Size	Required Torque (N-m)	Wire range
WJ200-004M	M3.5	1.2	AWG12 (3.3mm <sup>2</sup> )
WJ200-007M	M4	1.4	AWG10 (5.3mm <sup>2</sup> )

## Fuse Sizes

The inverter shall be connected with a UL Listed Cartridge Nonrenewable fuse, rated 600Vac with the current ratings as shown in the table below or Type E Combination Motor Controller marking is to indicate that the unit shall be connected with, LS Industrial System Co., Ltd, Type E Combination Motor Controller MMS Series with the ratings as shown in the table below:

Inverter Model	Fuse (UL-rated, class J, 600V , Maximum allowable current)	Type E C.M.C.
WJ200-004M	50A, AIC 200kA	MMS-32H, 120 V, 40 A
WJ200-007M		

## Inverter Specification Label

The Hitachi WJ200 inverters have product labels located on the right side of the housing, as pictured below. Be sure to verify that the specifications on the labels match your power source, and application safety requirements.

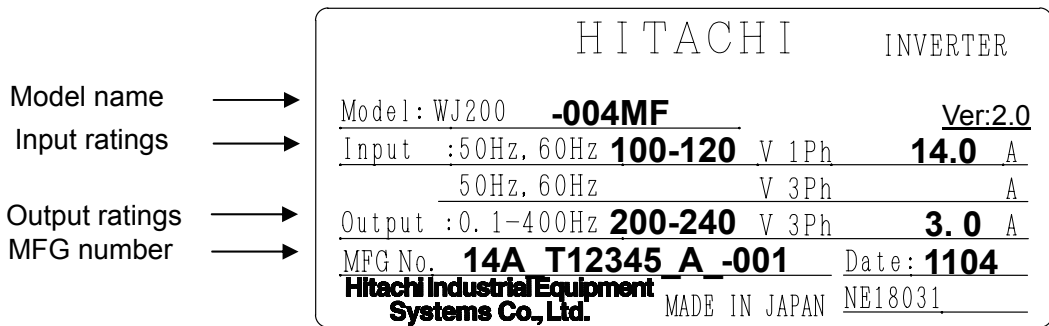

## Inverter Specification Label

The model number for a specific inverter contains useful information about its operating characteristics. Refer to the model number legend below:

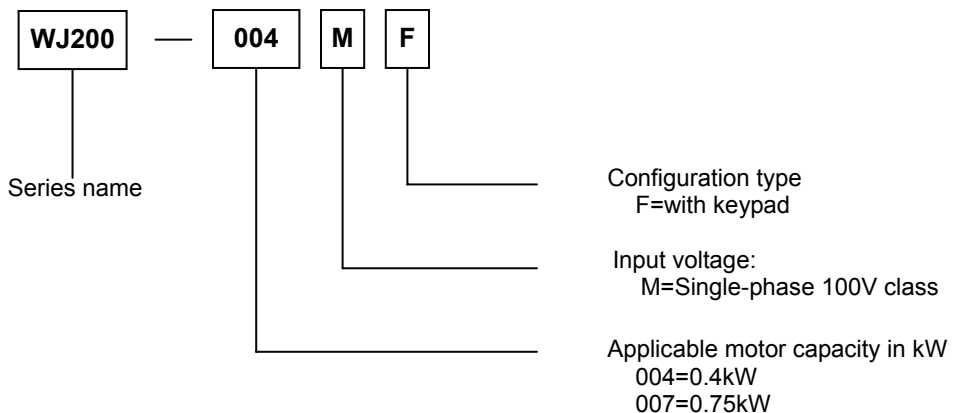

# WJ200 Inverter Specifications

## Model-specific tables for the Single-phase 100V class inverters

The following tables are specific to WJ200 inverters for the Single-phase 100V class model groups. Note that “General Specifications” on page in this chapter apply to both voltage class groups. Footnotes for all specification tables follow the table below.

Item		Single-phase 100V class Specifications	
WJ200 inverters, 100V models		004MF	007MF
Applicable motor size	kW	0.4	0.75
	HP	1/2	1
Rated capacity (kVA)	100V	1.0	1.7
	120V	1.2	2.0
Rated input voltage		Single-phase: 100V to 120V $\pm 10\%$ , 50/60Hz $\pm 5\%$	
Rated output voltage *3		Three-phase: 200 to 240V (proportional to input voltage)	
Rated output current (A) *12		3.0 (2.6)	5.0 (4.0)
Braking	Without resistor *6	100%: $\leq 50\text{Hz}$ 50%: $\leq 60\text{Hz}$	
	With resistor	150%	
DC braking		Variable operating frequency, time, and braking force	
Weight	kg	1.1	1.6
	lb	2.4	3.5

## General Specifications

The following table applies to Single-phase 100V class WJ200 inverters.

Item		General Specifications	
Protective housing *1		IP20	
Control method		Sinusoidal Pulse Width Modulation (PWM) control	
Carrier frequency		2kHz to 15kHz (derating required depending on the model)	
Output frequency range *4		0.1 to 400Hz	
Frequency accuracy		Digital command: $\pm 0.01\%$ of the maximum frequency Analog command: $\pm 0.2\%$ of the maximum frequency ( $25^\circ\text{C} \pm 10^\circ\text{C}$ )	
Frequency setting resolution		Digital: 0.01Hz; Analog: max. frequency/1000	
Volt./Freq. characteristic		V/f control (constant torque, reduced torque, free-V/F): base freq. 30Hz~400Hz adjustable, Sensorless vector control, Closed loop control with motor encoder feedback	
Overload capacity		60 sec. @150%	
Acceleration/deceleration time		0.01 to 3600 seconds, linear and S-curve accel/decel, second accel/decel setting available	
Starting torque *5		200% @0.5Hz (IM: sensorless vector control) 50% @10% of base frequency (PM: sensorless vector control)	
Input signal	Freq. setting	Operator panel	Up and Down keys / Value settings
		External signal *7	0 to 10 VDC (input impedance 10k Ohms), 4 to 20mA (input impedance 100 Ohms), Potentiometer (1k to 2k Ohms, 2W)
		Via network	RS485 ModBus RTU, other network option
	FWD/REV run	Operator panel	Run/Stop (Forward/Reverse run change by command)
		External signal	Forward run/stop, Reverse run/stop
		Via network	RS485 ModBus RTU, other network option

Item		General Specifications
	Intelligent input terminal  Seven terminals, sink/source changeable by a short bar  68 functions assignable	<b>FW</b> (forward run command), <b>RV</b> (reverse run command), <b>CF1~CF4</b> (multi-stage speed setting), <b>JG</b> (jog command), <b>DB</b> (external braking), <b>SET</b> (set second motor), <b>2CH</b> (2-stage accel./decel. command), <b>FRS</b> (free run stop command), <b>EXT</b> (external trip), <b>USP</b> (startup function), <b>CS</b> (commercial power switchover), <b>SFT</b> (soft lock), <b>AT</b> (analog input selection), <b>RS</b> (reset), <b>PTC</b> (thermistor thermal protection), <b>STA</b> (start), <b>STP</b> (stop), <b>F/R</b> (forward/reverse), <b>PID</b> (PID disable), <b>PIDC</b> (PID reset), <b>UP</b> (remote control up function), <b>DWN</b> (remote control down function), <b>UDC</b> (remote control data clear), <b>OPE</b> (operator control), <b>SF1~SF7</b> (multi-stage speed setting; bit operation), <b>OLR</b> (overload restriction), <b>TL</b> (torque limit enable), <b>TRQ1</b> (torque limit changeover1), <b>TRQ2</b> (torque limit changeover2), <b>BOK</b> (Braking confirmation), <b>LAC</b> (LAD cancellation), <b>PCLR</b> (position deviation clear), <b>ADD</b> (add frequency enable), <b>F-TM</b> (force terminal mode), <b>ATR</b> (permission of torque command input), <b>KHC</b> (Cumulative power clear), <b>MI1~MI7</b> (general purpose inputs for EzSQ), <b>AHD</b> (analog command hold), <b>CP1~CP3</b> (multistage-position switches), <b>ORL</b> (limit signal of zero-return), <b>ORC</b> (trigger signal of zero-return), <b>SPD</b> (speed/position changeover), <b>GS1,GS2</b> (STO inputs, safety related signals), <b>485</b> (Starting communication signal), <b>PRG</b> (executing EzSQ program), <b>HLD</b> (retain output frequency), <b>ROK</b> (permission of run command), <b>EB</b> (rotation direction detection of B-phase), <b>DISP</b> (display limitation), <b>NO</b> (no function)
Output signal	Intelligent output terminal  48 functions assignable	<b>RUN</b> (run signal), <b>FA1~FA5</b> (frequency arrival signal), <b>OL,OL2</b> (overload advance notice signal), <b>OD</b> (PID deviation error signal), <b>AL</b> (alarm signal), <b>OTQ</b> (over/under torque threshold), <b>UV</b> (under-voltage), <b>TRQ</b> (torque limit signal), <b>RNT</b> (run time expired), <b>ONT</b> (power ON time expired), <b>THM</b> (thermal warning), <b>BRK</b> (brake release), <b>BER</b> (brake error), <b>ZS</b> (0Hz detection), <b>DSE</b> (speed deviation excessive), <b>POK</b> (positioning completion), <b>ODc</b> (analog voltage input disconnection), <b>OIdc</b> (analog current input disconnection), <b>FBV</b> (PID second stage output), <b>NDc</b> (network disconnect detection), <b>LOG1~LOG3</b> (Logic output signals), <b>WAC</b> (capacitor life warning), <b>WAF</b> (cooling fan warning), <b>FR</b> (starting contact), <b>OHF</b> (heat sink overheat warning), <b>LOC</b> (Low load), <b>MO1~MO3</b> (general outputs for EzSQ), <b>IRDY</b> (inverter ready), <b>FWR</b> (forward operation), <b>RVR</b> (reverse operation), <b>MJA</b> (major failure), <b>WCO</b> (window comparator O), <b>WCOI</b> (window comparator OI), <b>FREF</b> (frequency command source), <b>REF</b> (run command source), <b>SETM</b> (second motor in operation), <b>EDM</b> (STO (safe torque off) performance monitor), <b>OP</b> (option control signal), <b>NO</b> (no function)
	Monitor output (analog)	Output freq., output current, output torque, output voltage, input power, thermal load ratio, LAD freq., heat sink temperature, general output (EzSQ)
	Pulse train output (0~10Vdc, 32kHz max.)	<b>[PWM output]</b> Output freq., output current, output torque, output voltage, input power, thermal load ratio, LAD freq., heat sink temperature, general output (EzSQ) <b>[Pulse train output]</b> Output frequency, output current, pulse train input monitor
Alarm output contact		ON for inverter alarm (1c contacts, both normally open or closed available.)
Other functions		Free-V/f, manual/automatic torque boost, output voltage gain adjustment, AVR function, reduced voltage start, motor data selection, auto-tuning, motor stabilization control, reverse running protection, simple position control, simple torque control, torque limiting, automatic carrier frequency reduction, energy saving operation, PID function, non-stop operation at instantaneous power failure, brake control, DC injection braking, dynamic braking (BRD), frequency upper and lower limiters, jump frequencies, curve accel and decel (S, U, inversed U,EL-S), 16-stage speed profile, fine adjustment of start frequency, accel and decel stop, process jogging, frequency calculation, frequency addition, 2-stage accel/decel, stop mode selection, start/end freq., analog input filter, window comparators, input terminal response time, output signal delay/hold function, rotation direction restriction, stop key selection, software lock, safe stop function, scaling function, display restriction, password function, user parameter, initialization, initial display selection, cooling fan control, warning, trip retry, frequency pull-in restart, frequency matching, overload restriction, over current restriction, DC bus voltage AVR
Protective function		Over-current, over-voltage, under-voltage, overload, brake resistor overload, CPU error, memory error, external trip, USP error, ground fault detection at power on, temperature error, internal communication error, driver error, thermistor error, brake error, safe stop, overload at low speed, modbus communication error, option error, encoder disconnection, speed excessive, EzSQ command error, EzSQ nesting error, EzSQ execution error, EzSQ user trip
Operating environment	Temperature	Operating (ambient): -10 to 40°C(*8), / Storage: -20 to 65°C(*9)
	Humidity	20 to 90% humidity (non-condensing)

Item		General Specifications
	Vibration *10	5.9m/s <sup>2</sup> (0.6G), 10 to 55 Hz
	Location	Altitude 1,000m or less, indoors (no corrosive gasses or dust)
Coating color		Black
Options		Remote operator unit, cables for the units, braking unit, braking resistor, fieldbus

Footnotes for the preceding table and the tables that follow:

**Note1:** The protection method conforms to JIC C 0920.

**Note2:** The applicable motor refers to Hitachi standard 3-phase motor (4p). When using other motors, care must be taken to prevent the rated motor current (50/60Hz) from exceeding the rated output current of the inverter.

**Note3:** The output voltage decreases as the main supply voltage decreases (except when using the AVR function). In any case, the output voltage cannot exceed the input power supply voltage. In any case, the output voltage cannot exceed two times the input power supply voltage

**Note4:** To operate the motor beyond 50/60Hz, consult the motor manufacturer for the maximum allowable rotation speed.

**Note5:** At the rated voltage when using a Hitachi standard 3-phase, 4-pole motor.

**Note6:** The braking torque via capacitive feedback is the average deceleration torque at the shortest deceleration (stopping from 50/60Hz as indicated). It is not continuous regenerative braking torque. The average deceleration torque varies with motor loss. This value decreases when operating beyond 50Hz. If a large regenerative torque is required, the optional regenerative braking unit and a resistor should be used.

**Note7:** The frequency command is the maximum frequency at 9.8V for input voltage 0 to 10VDC, or at 19.6mA for input current 4 to 20mA. If this characteristic is not satisfactory for your application, contact your Hitachi representative.

**Note8:** If the inverter is operated outside the region shown in the graph in the derating curve, the inverter may be damaged or its service life may be shortened. Set ~~b003~~ Carrier Frequency Adjustment in accordance with the expected output current level. See derating curve section for the detailed information of the inverter operating range.

**Note9:** The storage temperature refers to the short-term temperature during transportation.

**Note10:** Conforms to the test method specified in JIS JIS C 60068-2-6 :2010(IEC 60068-2-6:2007). For the model types excluded in the standard specifications, contact your Hitachi sales representative.

**Note11:** Watt losses are calculated values based on specification of main semi-conductors. You must take suitable margin when designing cabinet based on these values. Otherwise there is a possibility of heating trouble.

**Note12:** "When the ambient temperature exceeds 40C, output current must be limited to the value in ( ).

## Signal Ratings

Detailed ratings are in "Control Logic Signal Specifications" in Page 16.

Signal / Contact	Ratings
Built-in power for inputs	24VDC, 100mA maximum
Discrete logic inputs	27VDC maximum
Discrete logic outputs	50mA maximum ON state current, 27 VDC maximum OFF state voltage
Analog output	10bit / 0 to 10VDC, 2mA
Analog input, current	4 to 19.6 mA range, 20mA nominal
Analog input, voltage	0 to 9.8 VDC range, 10VDC nominal, input impedance 10kΩ
+10V analog reference	10VDC nominal, 10mA maximum
Alarm relay contacts	250 VAC, 2.5A (R load) max., 0.2A (I load, P.F.=0.4) max. 100 VAC, 10mA min 30 VDC, 3.0A (R load) max., 0.7A (I load, P.F.=0.4) max.) 5 VDC, 100mA min.

# Basic System Description

A motor control system will obviously include a motor and inverter, as well as a circuit breaker or fuses for safety. If you are connecting a motor to the inverter on a test bench just to get started, that's all you may need for now. But a system can also have a variety of additional components. Some can be for noise suppression, while others may enhance the inverter's braking performance. The figure and table below show a system with all the **optional** components you might need in your finished application.

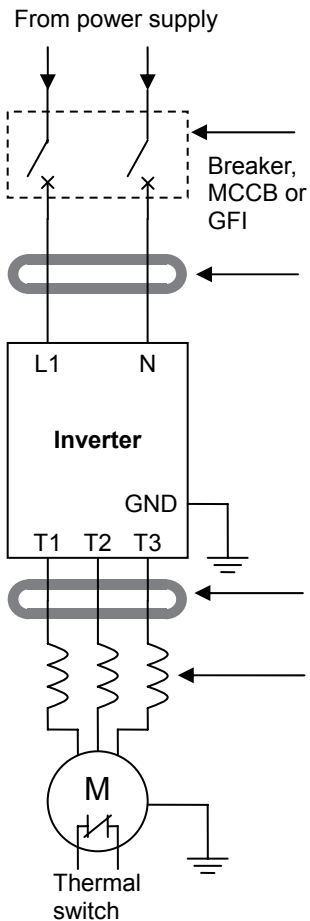

Name	Function
Breaker / disconnect	A molded-case circuit breaker (MCCB), ground fault interrupter (GFI), Type E Combination Motor Controller (Type E C.M.C) or a fused disconnect device. NOTE: The installer must refer to the NEC and local codes to ensure safety and compliance.
Radio noise filter	Electrical noise interference may occur on nearby equipment such as a radio receiver. This magnetic choke filter helps reduce radiated noise (can also be used on output).
Radio noise filter	Electrical noise interference may occur on nearby equipment such as a radio receiver. This magnetic choke filter helps reduce radiated noise (can also be used on input).
Output-side AC Reactor	This reactor reduces the vibration in the motor caused by the inverter's switching waveforms, by smoothing the waveform to approximate commercial power quality. It is also useful to reduce harmonics when wiring from the inverter to the motor is more than 10m in length.



## Determining Wire and Fuse Sizes

The maximum motor currents in your application determines the recommended wire size. The following table gives the wire size in AWG. The “Power Lines” column applies to the inverter input power, output wires to the motor, the earth ground connection, and any other components shown in the “Basic System Description” on page 7. The “Signal Lines” column applies to any wire connecting to the two green connectors just inside the front cover panel.

Motor Output		Inverter Model	Wiring		Applicable equipment	
kW	HP		Power Lines	Signal Lines	Fuse (UL-rated, class J, 600V , Maximum allowable current)	Type E C.M.C.
0.4	1/2	WJ200-004MF	AWG12 / 3.3mm <sup>2</sup>	18 to 28 AWG / 0.14 to 0.75 mm <sup>2</sup> shielded wire (see Note 4)	50A	MMS-32H, 120 V, 40 A
0.75	1	WJ200-007MF	AWG10 / 5.3mm <sup>2</sup>		50A	MMS-32H, 120 V, 40 A

**Note 1:** Field wiring must be made by a UL-Listed and CSA-certified closed-loop terminal connector sized for the wire gauge involved. Connector must be fixed by using the crimping tool specified by the connector manufacturer.

**Note 2:** Be sure to consider the capacity of the circuit breaker to be used.

**Note 3:** Be sure to use a larger wire gauge if power line length exceeds 66ft. (20m).

**Note 4:** Use 18 AWG / 0.75mm<sup>2</sup> wire for the alarm signal wire ([AL0], [AL1], [AL2] terminals).

**Note 5:** Type E Combination Motor Controller marking is to indicate that the unit shall be connected with, LS Industrial System Co., Ltd, Type E Combination Motor Controller MMS Series .

## Wire the Inverter Input to a Supply

In this step, you will connect wiring to the input of the inverter. This Inverter is single-phase power only. The power connection terminals are **[L1]** and **[N]**. **So you must refer to the specifications label (on the side of the inverter) for the acceptable power source types!** Single-phase inverter models will have no connection to the [S/L2] terminal. This is only used for three-phase models. Note the use of ring lug connectors is recommended for a secure connection.

### Single-phase 100V 0.4kW

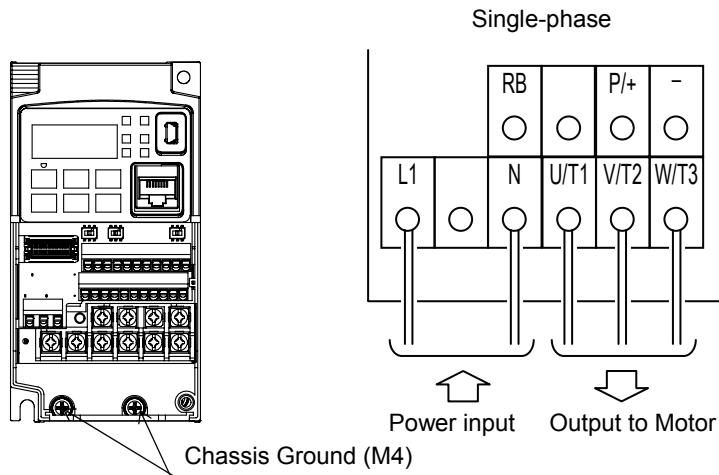

### Single-phase 100V 0.75kW

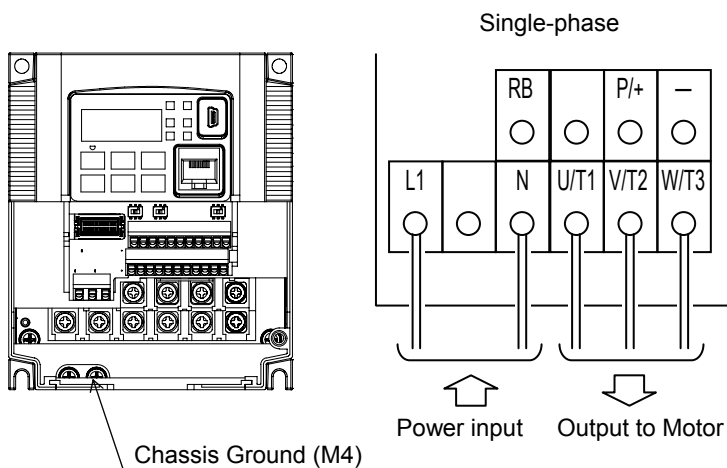

**NOTE:** An inverter powered by a portable power generator may cause a distorted power waveform, overheating the generator. In general, the generator capacity should be five times that of the inverter (kVA).

# Using the Front Panel Keypad

Please take a moment to familiarize yourself with the keypad layout shown in the figure below. The display is used in programming the inverter's parameters, as well as monitoring specific parameter values during operation.

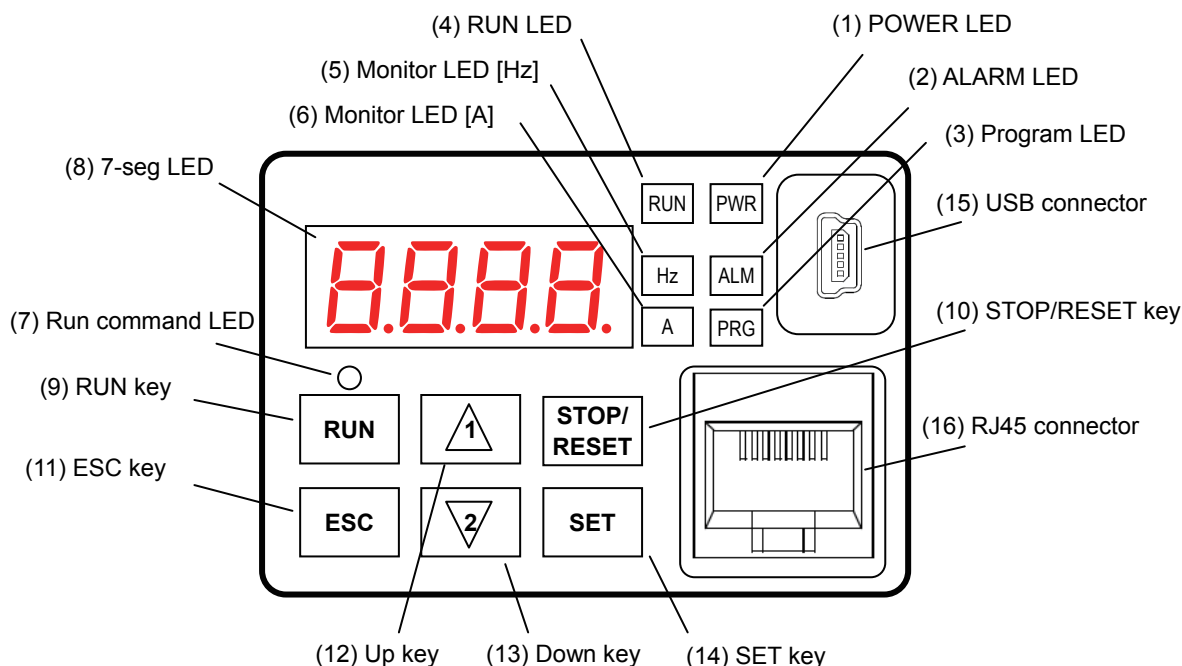

## Key and Indicator Legend

Items	Contents
(1) POWER LED	Turns ON (Green) while the inverter is powered up.
(2) ALARM LED	Turns ON (Red) when the inverter trips.
(3) Program LED	<ul style="list-style-type: none"> <li>➤ Turns ON (Green) when the display shows changeable parameter.</li> <li>➤ Blinks when there is a mismatch in setting.</li> </ul>
(4) RUN LED	Turns ON (Green) when the inverter is driving the motor.
(5) Monitor LED [Hz]	Turns ON (Green) when the displayed data is frequency related.
(6) Monitor LED [A]	Turns ON (Green) when the displayed data is current related.
(7) Run command LED	Turns ON (Green) when the RUN command source is set to the operator. (Run key is effective.)
(8) 7-seg LED	Shows each parameter, monitors etc.
(9) RUN key	Makes inverter run.
(10) STOP/RESET key	<ul style="list-style-type: none"> <li>➤ Makes inverter stop, according to parameter setup.</li> <li>➤ Reset the inverter when it is in trip situation</li> </ul>
(11) ESC key	<ul style="list-style-type: none"> <li>➤ Go to the top of next function group, when a function mode is shown</li> <li>➤ Cancel the setting and return to the function code, when a data is shown</li> <li>➤ Moves the cursor to a digit left, when it is in digit-to-digit setting mode</li> <li>➤ Pressing for 1 second leads to display data of <b>d00 I</b>, regardless of current display.</li> </ul>
(12) Up key	<ul style="list-style-type: none"> <li>➤ Increase or decrease the data.</li> </ul>
(13) Down key	<ul style="list-style-type: none"> <li>➤ Pressing the both keys at the same time gives you the digit-to-digit edit.</li> </ul>
(14) SET key	<ul style="list-style-type: none"> <li>➤ Go to the data display mode when a function code is shown</li> <li>➤ Stores the data and go back to show the function code, when data is shown.</li> <li>➤ Moves the cursor to a digit right, when it is in digit-to-digit display mode</li> </ul>
(15) USB connector	Connect USB connector (mini-B) for using PC communication
(16) RJ45 connector	Connect RJ45 jack for remote operator

## Keys, Modes, and Parameters

The purpose of the keypad is to provide a way to change modes and parameters. The term *function* applies to both monitoring modes and parameters. These are all accessible through *function codes* that are primary 4-character codes. The various functions are separated into related groups identifiable by the left-most character, as the table shows.

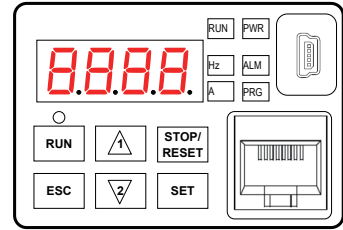



Function Group	Type (Category) of Function	Mode to Access	PRG LED Indicator
"d"	Monitoring functions	Monitor	○
"F"	Main profile parameters	Program	●
"A"	Standard functions	Program	●
"b"	Fine tuning functions	Program	●
"C"	Intelligent terminal functions	Program	●
"H"	Motor constant related functions	Program	●
"P"	Pulse train input, torque, EzSQ, and communication related functions	Program	●
"U"	User selected parameters	Program	●
"E"	Error codes	—	—

You can see from the following page how to monitor and/or program the parameters.

## Keypad Navigation Map

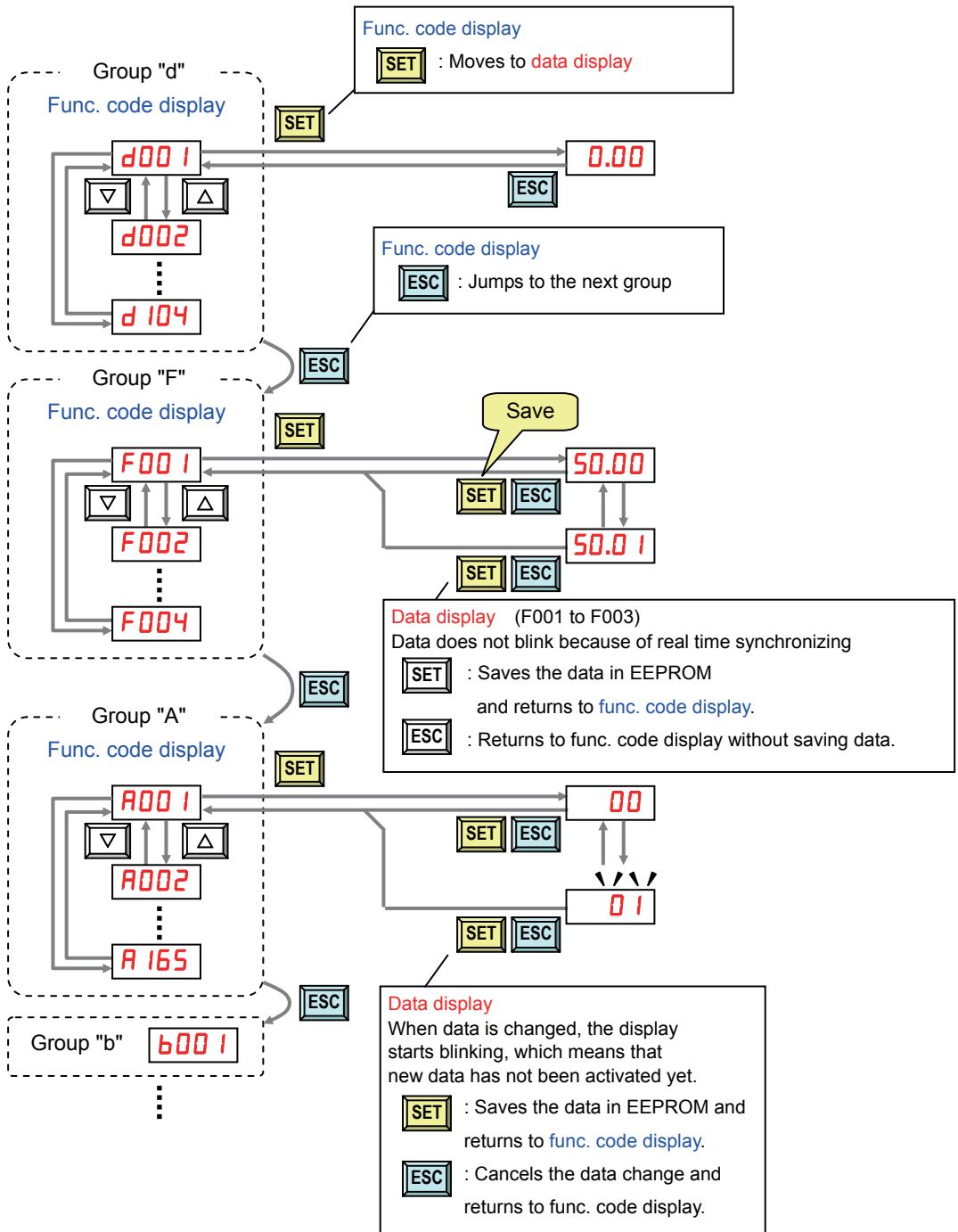
The WJ200 Series inverter drives have many programmable functions and parameters. Chapter 3 will cover these in detail, but you need to access just a few items to perform the powerup test. The menu structure makes use of function codes and parameter codes to allow programming and monitoring with only a 4-digit display and keys and LEDs. So, it is important to become familiar with the basic navigation map of parameters and functions in the diagram below. You may later use this map as a reference.





 Press the both up and down key at the same time in **func. code** or **data display**, then single-digit edit mode will be enabled. Refer to 2-34 for further information.

**NOTE:** Pressing the [ESC] key will make the display go to the top of next function group, regardless the display contents. (e.g. *A02 1* → [ESC] → *b00 1*)

[Setting example]

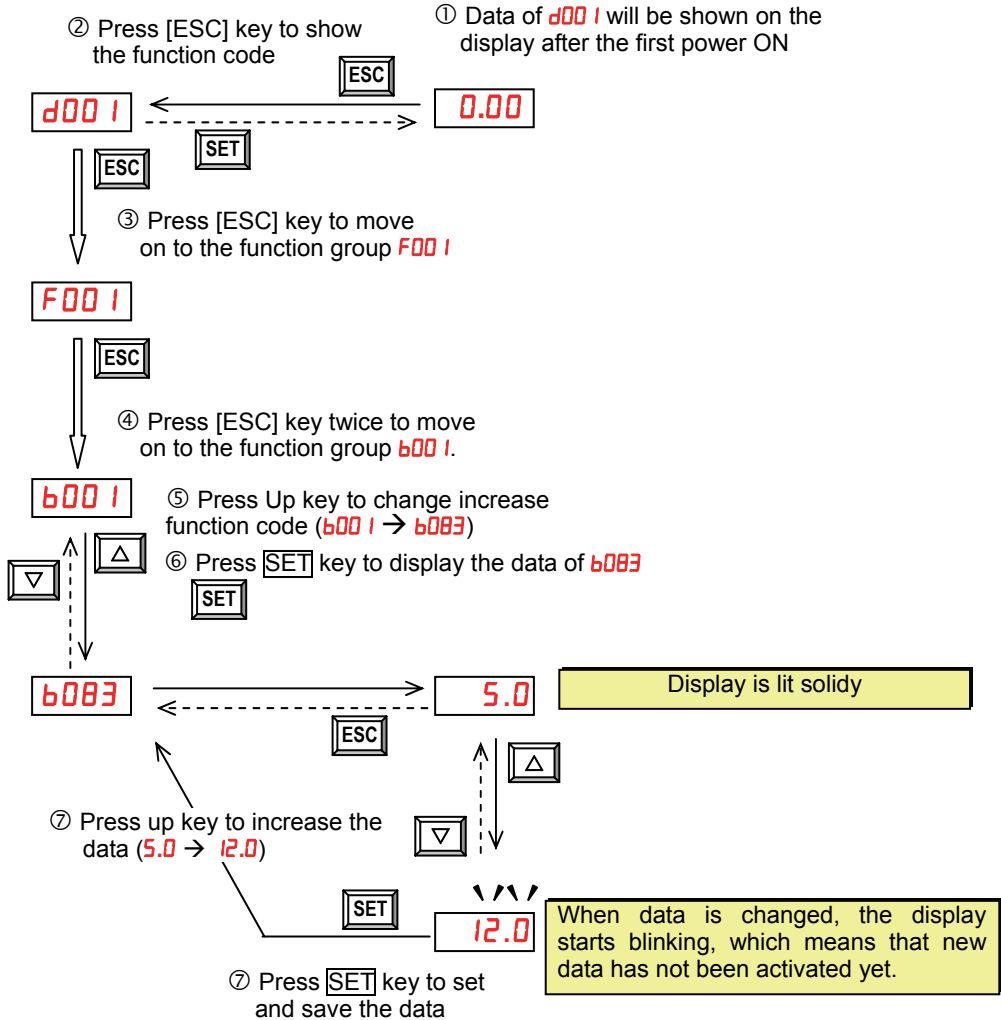
After power ON, changing from 0.00 display to change the b003 (carrier frequency) data.



- :Fix and stores the data and moves back to the function code
- :Cancels the change and moves back to the function code



Function code **dxxx** are for monitor and not possible to change.

Function codes **Fxxx** other than **F004** are reflected on the performance just after changing the data (before pressing [SET] key), and there will be no blinking.

	When a function code is shown...	When data is shown...
	Move on to the next function group	Cancels the change and moves back to the function code
	Move on to the data display	Fix and stores the data and moves back to the function code
	Increase function code	Increase data value
	Decrease function code	Decrease data value

Note

Keep pressing for more than 1 second leads to d001 display, regardless the display situation. But note that the display will circulates while keep pressing the [ESC] key because of the original function of the key. (e.g. **F001** → **A001** → **b001** → **C001** → ... → displays **50.00** after 1 second)

# Connecting to PLCs and Other Devices

Hitachi inverters (drives) are useful in many types of applications. During installation, the inverter keypad (or other programming device) will facilitate the initial configuration. After installation, the inverter will generally receive its control commands through the control logic connector or serial interface from another controlling device. In a simple application such as single-conveyor speed control, a Run/Stop switch and potentiometer will give the operator all the required control. In a sophisticated application, you may have a *programmable logic controller* (PLC) as the system controller, with several connections to the inverter.

It is not possible to cover all the possible types of application in this manual. It will be necessary for you to know the electrical characteristics of the devices you want to connect to the inverter. Then, this section and the following sections on I/O terminal functions can help you quickly and safely connect those devices to the inverter.



**CAUTION:** It is possible to damage the inverter or other devices if your application exceeds the maximum current or voltage characteristics of a connection point.

The connections between the inverter and other devices rely on the electrical input/output characteristics at both ends of each connection, shown in the diagram to the right.

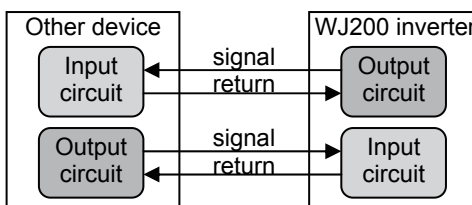

The inverter's configurable inputs accept either a sourcing or sinking output from an external device (such as PLC). This chapter shows the inverter's internal electrical component(s) at each I/O terminal. In some cases, you will need to insert a power source in the interface wiring.

In order to avoid equipment damage and get your application running smoothly, we recommend drawing a schematic of each connection between the inverter and the other device. Include the internal components of each device in the schematic, so that it makes a complete circuit loop.

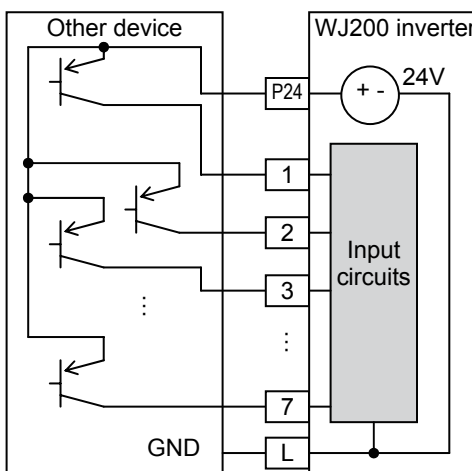

After making the schematic, then:

1. Verify that the current and voltage for each connection is within the operating limits of each device.
2. Make sure that the logic sense (active high or active low) of any ON/OFF connection is correct.
3. Check the zero and span (curve end points) for analog connections, and be sure the scale factor from input to output is correct.
4. Understand what will happen at the system level if any particular device suddenly loses power, or powers up after other devices.

# Example Wiring Diagram

The schematic diagram below provides a general example of logic connector wiring, in addition to basic power and motor wiring converted in Chapter 2. The goal of this chapter is to help you determine the proper connections for the various terminals shown below for your application needs.

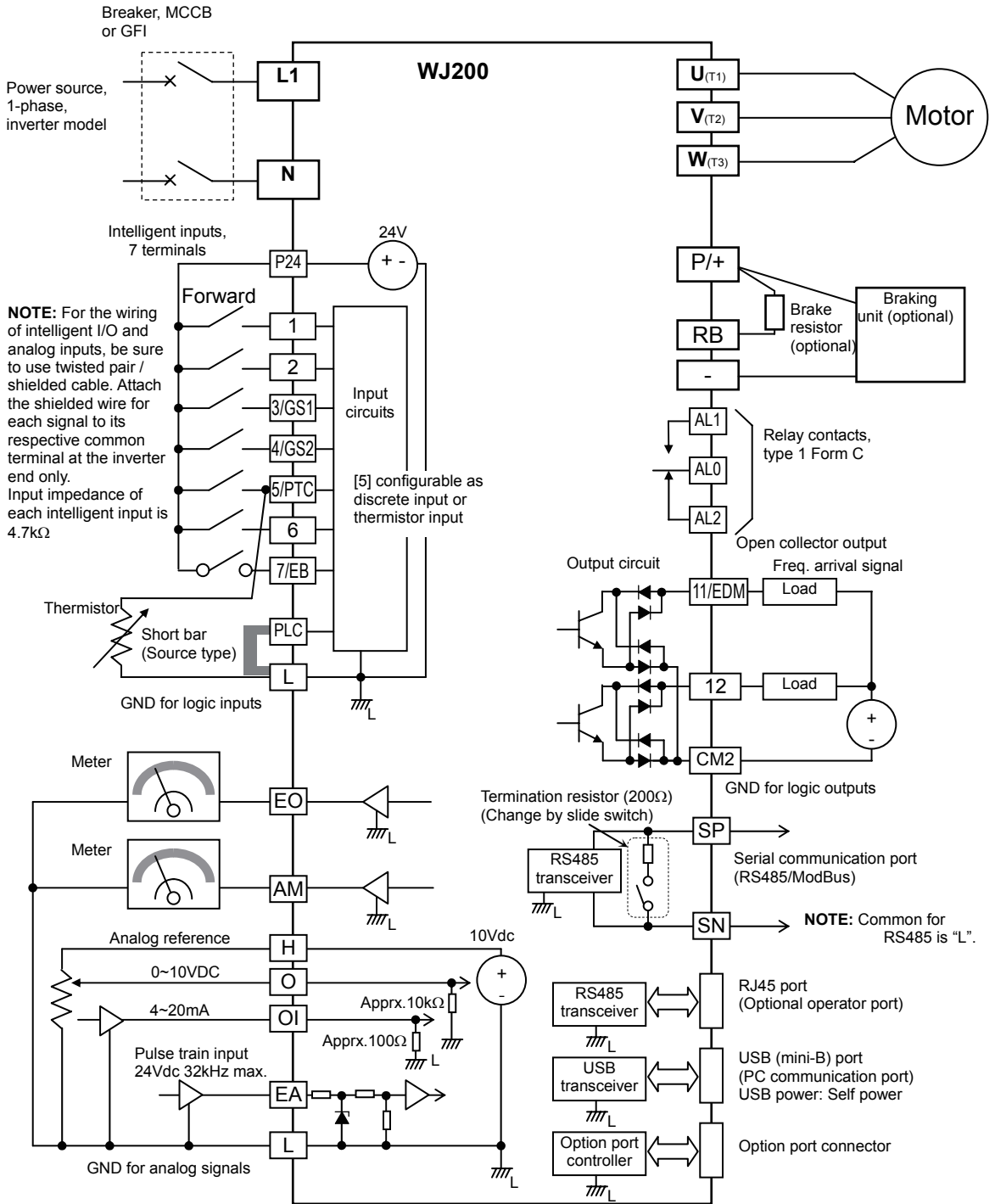



# Control Logic Signal Specifications

The control logic connectors are located just behind the front housing cover. The relay contacts are just to the left of the logic connectors. Connector labeling is shown below.

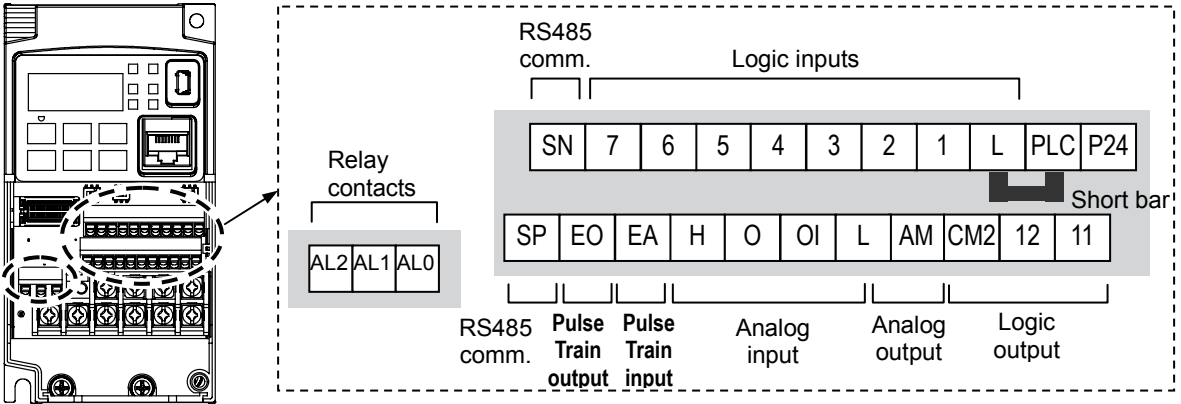

Terminal Name	Description	Ratings
P24	+24V for logic inputs	24VDC, 100mA. (do not short to terminal L)
PLC	Intelligent input common	To change to sink type, remove the short bar between [PLC] and [L], and connect it between [P24] and [L]. In this case, connecting [L] to [1]~[7] makes each input ON. Please remove the short bar when using external power supply.
1 2 3/GS1 4/GS2 5/PTC 6 7/EB	Discrete logic inputs (Terminal [3],[4],[5] and [7] have dual function. See following description and related pages for the details.)	27VDC max. (use PLC or an external supply referenced to terminal L)
GS1(3)	Safe stop input GS1	Functionality is based on ISO13849-1 See appendix for the details.
GS2(4)	Safe stop input GS2	
PTC(5)	Motor thermistor input	Connect motor thermistor between PTC and L terminal to detect the motor temperature. Set <b>19</b> in <b>C005</b> .
EB(7)	Pulse train input B	2kHz max. Common is [PLC]
EA	Pulse train input A	32kHz max. Common is [L]
L (in upper row) *1	GND for logic inputs	Sum of input [1]~[7] currents (return)
11/EDM	Discrete logic outputs [11] (Terminal [11] has dual function. See following description and related pages for the details.)	50mA max. ON state current, 27 VDC max. OFF state voltage Common is CM2 In case the EDM is selected, the functionality is based on ISO13849-1 4VDC max. ON state voltage depression
12	Discrete logic outputs [12]	50mA max. ON state current, 27 VDC max. OFF state voltage Common is CM2
CM2	GND for logic output	100 mA: [11], [12] current return
AM	Analog voltage output	0~10VDC 2mA maximum
EO	Pulse train output	10VDC 2mA maximum 32kHz maximum
L (in bottom row) *2	GND for analog signals	Sum of [OI], [O], and [H] currents (return)
OI	Analog current input	4 to 19.6 mA range, 20 mA nominal,

Terminal Name	Description	Ratings
		input impedance 100 Ω
O	Analog voltage input	0 to 9.8 VDC range, 10 VDC nominal, input impedance 10 kΩ
H	+10V analog reference	10VDC nominal, 10mA max.
SP, SN	Serial communication terminal	For RS485 Modbus communication.
AL0, AL1, AL2 *3	Relay common contact	250VAC, 2.5A (R load) max. 250VAC, 0.2A (I load, P.F.=0.4) max. 100VAC, 10mA min. 30VDC, 3.0A (R load) max. 30VDC, 0.7A (I load, P.F.=0.4) max. 5VDC, 100mA min.

**Note 1:** The two terminals [L] are electrically connected together inside the inverter.

**Note 2:** We recommend using [L] logic GND (to the right) for logic input circuits and [L] analog GND (to the left) for analog I/O circuits.

**Note 3:** Refer to page 39 for details of trip signals.

### Wiring sample of control logic terminal (source logic)

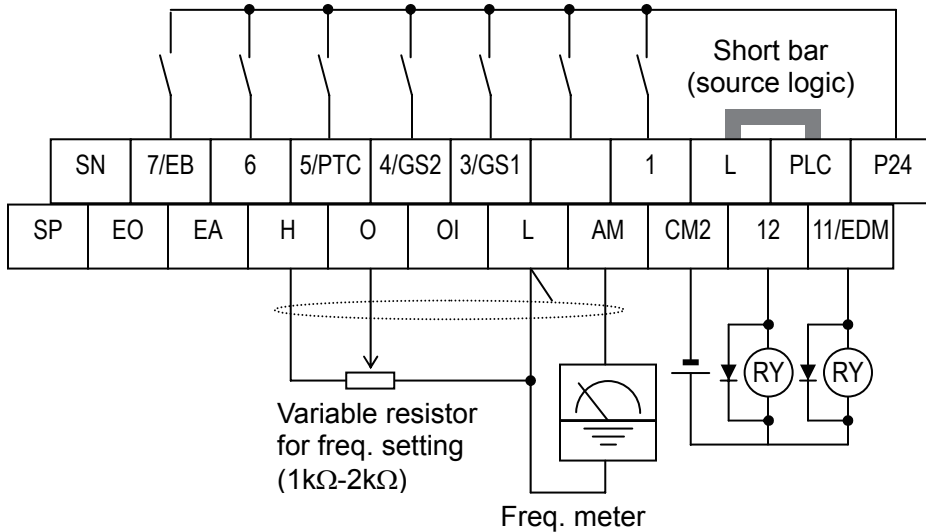

**Note:** If relay is connected to intelligent output, install a diode across the relay coil (reverse-biased) in order to suppress the turn-off spike.

### Sink/source logic of intelligent input terminals

Sink or source logic is switched by a short bar as below.

Sink logic

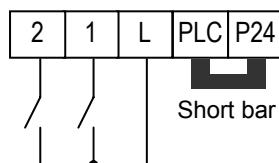

Source logic

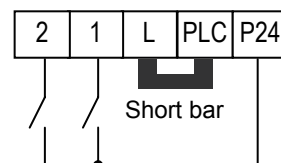

## Wire size for control and relay terminals

Use wires within the specifications listed below. For safe wiring and reliability, it is recommended to use ferrules, but if solid or stranded wire is used, stripping length should be 8mm.

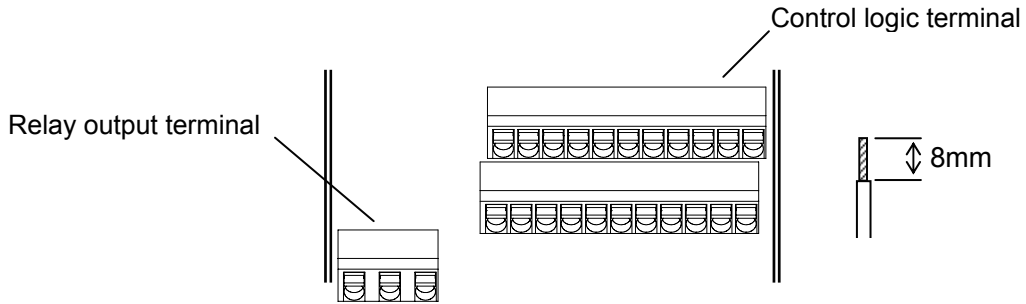

	Solid mm <sup>2</sup> (AWG)	Stranded mm <sup>2</sup> (AWG)	Ferrule mm <sup>2</sup> (AWG)
Control logic terminal	0.2 to 1.5 (AWG 24 to 16)	0.2 to 1.0 (AWG 24 to 17)	0.25 to 0.75 (AWG 24 to 18)
Relay terminal	0.2 to 1.5 (AWG 24 to 16)	0.2 to 1.0 (AWG 24 to 17)	0.25 to 0.75 (AWG 24 to 18)

### Recommended ferrule

For safe wiring and reliability, it is recommended to use following ferrules.

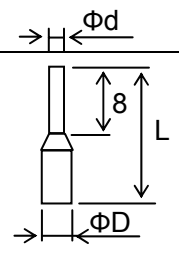
Wire size mm <sup>2</sup> (AWG)	Model name of ferrule *	L [mm]	Φd [mm]	ΦD [mm]	
0.25 (24)	AI 0.25-8YE	12.5	0.8	2.0	
0.34 (22)	AI 0.34-8TQ	12.5	0.8	2.0	
0.5 (20)	AI 0.5-8WH	14	1.1	2.5	
0.75 (18)	AI 0.75-8GY	14	1.3	2.8	

\* Supplier: Phoenix contact

Crimping pliers: CRIPMFOX UD 6-4 or CRIMPFOX ZA 3

### How to connect?

- (1) Push down the orange actuating lever by a slotted screwdriver (width 2.5mm max.).
- (2) Insert the conductor.
- (3) Pull out the screwdriver then the conductor is fixed.

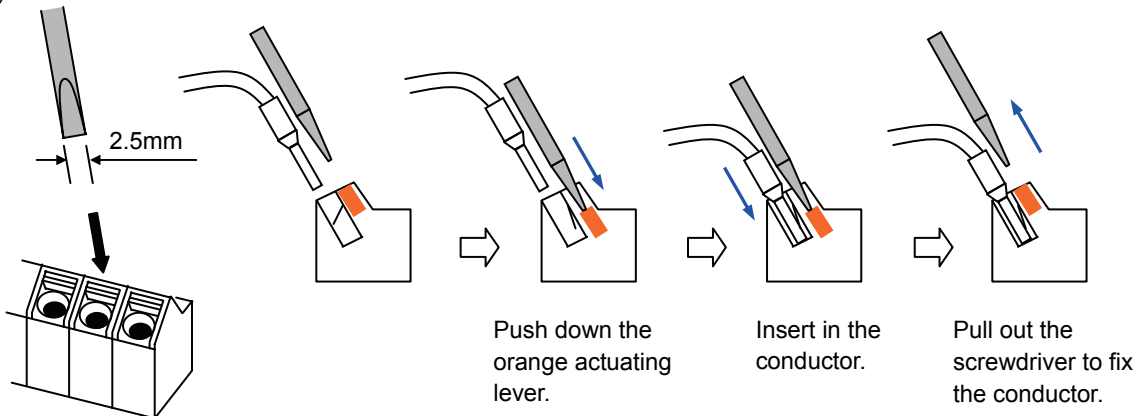

# Intelligent Terminal Listing

## Intelligent Inputs

Use the following table to locate pages for intelligent input material in this chapter.

Input Function Summary Table			
Symbol	Code	Function Name	Page
FW	00	Forward Run/Stop	
RV	01	Reverse Run/Stop	
CF1	02	Multi-speed Select, Bit 0 (LSB)	
CF2	03	Multi-speed Select, Bit 1	
CF3	04	Multi-speed Select, Bit 2	
CF4	05	Multi-speed Select, Bit 3 (MSB)	
JG	06	Jogging	
DB	07	External DC braking	
SET	08	Set (select) 2nd Motor Data	
2CH	09	2-stage Acceleration and Deceleration	
FRS	11	Free-run Stop	
EXT	12	External Trip	
USP	13	Unattended Start Protection	
CS	14	Commercial power source switchover	
SFT	15	Software Lock	
AT	16	Analog Input Voltage/Current Select	
RS	18	Reset Inverter	
PTC	19	PTC thermistor Thermal Protection	
STA	20	Start (3-wire interface)	
STP	21	Stop (3-wire interface)	
F/R	22	FWD, REV (3-wire interface)	
PID	23	PID Disable	
PIDC	24	PID Reset	
UP	27	Remote Control UP Function	
DWN	28	Remote Control Down Function	
UDC	29	Remote Control Data Clearing	
OPE	31	Operator Control	
SF1~SF7	32~38	Multi-speed Select, Bit operation Bit 1~7	
OLR	39	Overload Restriction Source Changeover	
TL	40	Torque Limit Selection	
TRQ1	41	Torque limit switch 1	
TRQ2	42	Torque limit switch 2	
BOK	44	Brake confirmation	
LAC	46	LAD cancellation	
PCLR	47	Pulse counter clear	
ADD	50	ADD frequency enable	
F-TM	51	Force Terminal Mode	
ATR	52	Permission for torque command input	
KHC	53	Clear watt-hour data	
MI1~MI7	56~62	General purpose input (1)~(7)	
AHD	65	Analog command hold	
CP1~CP3	66~68	Multistage-position switch (1)~(3)	
ORL	69	Limit signal of zero-return	
ORG	70	Trigger signal of zero-return	
SPD	73	Speed/position changeover	
GS1	77	STO1 input (Safety related signal)	
GS2	78	STO2 input (Safety related signal)	
485	81	Starting communication signal	
PRG	82	Executing EzSQ program	
HLD	83	Retain output frequency	
ROK	84	Permission of Run command	
EB	85	Rotation direction detection (phase B)	

Use the following table to locate pages for intelligent input material in this chapter.

Input Function Summary Table			
Symbol	Code	Function Name	Page
DISP	86	Display limitation	
NO	255	No assign	

## Intelligent Outputs

Use the following table to locate pages for intelligent output material in this chapter.

Input Function Summary Table			
Symbol	Code	Function Name	Page
RUN	00	Run Signal	
FA1	01	Frequency Arrival Type 1–Constant Speed	
FA2	02	Frequency Arrival Type 2–Over frequency	
OL	03	Overload Advance Notice Signal	
OD	04	PID Deviation error signal	
AL	05	Alarm Signal	
FA3	06	Frequency Arrival Type 3–Set frequency	
OTQ	07	Over/under Torque Threshold	
UV	09	Undervoltage	
TRQ	10	Torque Limited Signal	
RNT	11	Run Time Expired	
ONT	12	Power ON time Expired	
THM	13	Thermal Warning	
BRK	19	Brake Release Signal	
BER	20	Brake Error Signal	
ZS	21	Zero Hz Speed Detection Signal	
DSE	22	Speed Deviation Excessive	
POK	23	Positioning Completion	
FA4	24	Frequency Arrival Type 4–Over frequency	
FA5	25	Frequency Arrival Type 5–Set frequency	
OL2	26	Overload Advance Notice Signal 2	
ODc	27	Analog Voltage Input Disconnect Detection	
OIDc	28	Analog Voltage Output Disconnect Detection	
FBV	31	PID Second Stage Output	
NDc	32	Network Disconnect Detection	
LOG1~3	33~35	Logic Output Function 1~3	
WAC	39	Capacitor Life Warning Signal	
WAF	40	Cooling Fan Warning Signal	
FR	41	Starting Contact Signal	
OHF	42	Heat Sink Overheat Warning	
LOC	43	Low load detection	
MO1~3	44~46	General Output 1~3	
IRDY	50	Inverter Ready Signal	
FWR	51	Forward Operation	
RVR	52	Reverse Operation	
MJA	53	Major Failure Signal	
WCO	54	Window Comparator for Analog Voltage Input	
WCOI	55	Window Comparator for Analog Current Input	
FREF	58	Frequency Command Source	
REF	59	Run Command Source	
SETM	60	2 <sup>nd</sup> Motor in operation	
EDM	62	STO (Safe Torque Off) Performance Monitor (Output terminal 11 only)	
OP	63	Option control signal	
no	255	Not used	

# Using Intelligent Input Terminals

Terminals [1], [2], [3], [4], [5], [6] and [7] are identical, programmable inputs for general use. The input circuits can use the inverter's internal (isolated) +24V field supply or an external power supply. This section describes input circuits operation and how to connect them properly to switches or transistor outputs on field devices.

The WJ200 inverter features selectable *sinking* or *sourcing* inputs. These terms refer to the connection to the external switching device—it either *sinks* current (from the input to GND) or *sources* current (from a power source) into the input. Note that the sink/source naming convention may be different in your particular country or industry. In any case, just follow the wiring diagrams in this section for your application.

The inverter has a short bar (jumper) for configuring the choice of sinking or sourcing inputs. To access it, you must remove the front cover of the inverter housing. In the figure to the top right, the short bar is shown as attached to the logic terminal block (connector). If you need to change to the source type connection, remove the short bar and connect it as shown in the figure at the bottom right.

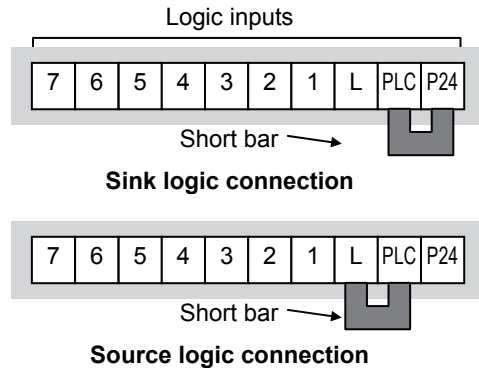

**CAUTION:** Be sure to turn OFF power to the inverter before changing the short circuit bar position. Otherwise, damage to the inverter circuitry may occur.

[PLC] Terminal Wiring – The [PLC] terminal (Programmable Logic Control terminal) is named to include various devices that can connect to the inverter's logic inputs. In the figure to the right, note the [PLC] terminal and the short bar (jumper). Locating the short bar between [PLC] and [L] sets the input logic source type, which is the default setting for EU and US versions. In this case, you connect input terminal to [P24] to make it active. If instead you locate the short bar between [PLC] and [P24], the input logic will be sink type. In this case, you connect the input terminal to [L] to make it active.

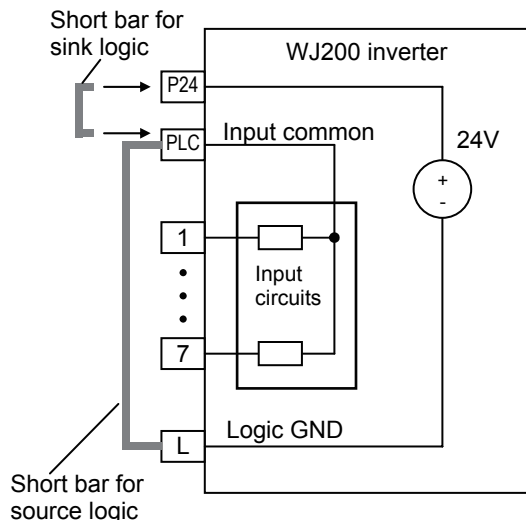

The wiring diagram on the following pages show the four combinations of using sourcing or sinking inputs, and using the internal or an external DC supply.

The two diagrams below input wiring circuits using the inverter's internal +24V supply. Each diagram shows the connection for simple switches, or for a field device with transistor outputs. Note that in the lower diagram, it is necessary to connect terminal [L] only when using the field device with transistors. Be sure to use the correct connection of the short bar shown for each wiring diagram.

**Sinking Inputs, Internal Supply**

Short bar = [PLC] – [P24] position

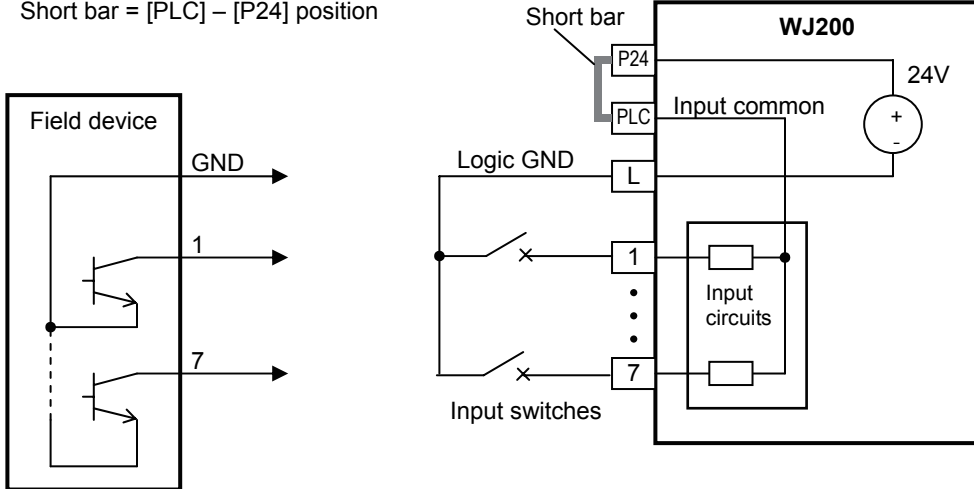

Open collector outputs,  
NPN transistors

**Sourcing Inputs, Internal Supply**

Short bar = [PLC] – [L] position

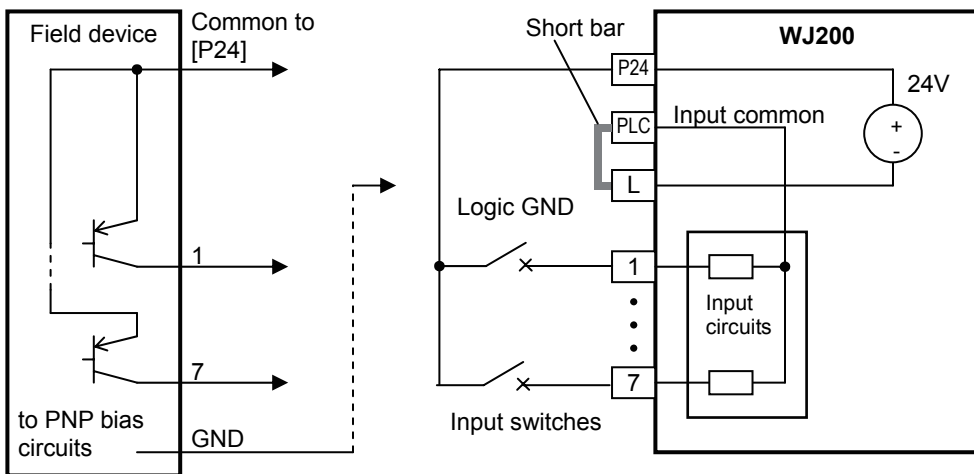

PNP transistor  
sourcing outputs

The two diagrams below show input wiring circuits using an external supply. If using the “Sinking Inputs, External Supply” in below wiring diagram, be sure to remove the short bar, and use a diode (\*) with the external supply. This will prevent a power supply contention in case the short bar is accidentally placed in the incorrect position. For the “Sourcing Inputs, External Supply”, please connect the short bar as drawn in the diagram below.

**Sinking Inputs, External Supply**

Short bar = Removed

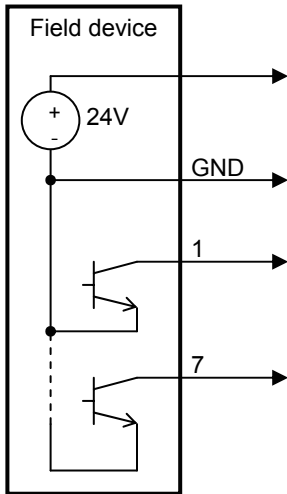

Open collector outputs, NPN transistors

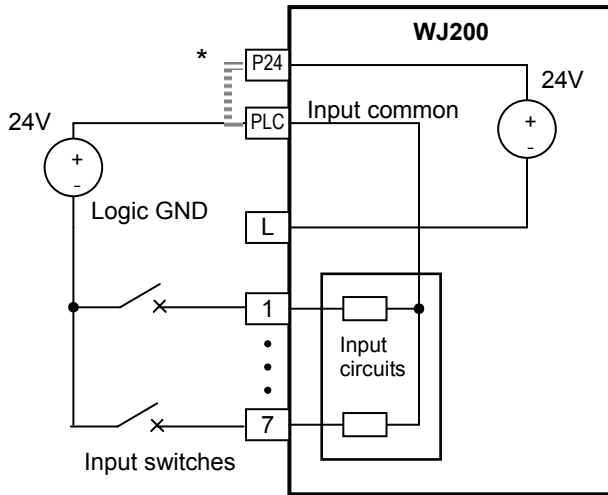

\* Note: Make sure to remove the short circuit bar in case of using an external power supply.

**Sourcing Inputs, External Supply**

Short bar = Removed

PNP transistor sourcing outputs

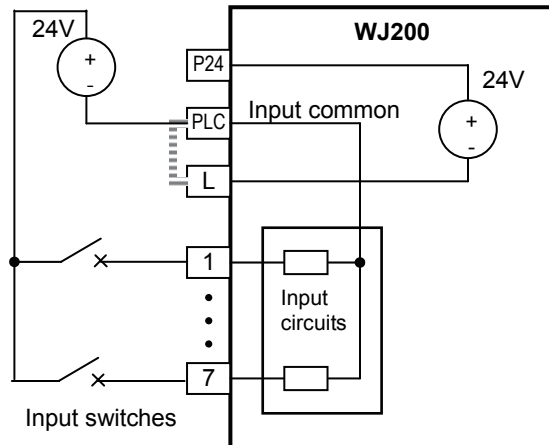
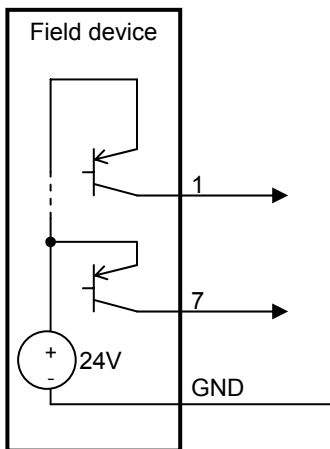





**CAUTION:** Be sure to install a diode in between "P24" and "PLC" when connecting multiple inverters with digital input wiring in common.

The power to the inverter control circuits can be supplied externally as shown below. It is possible to read and write parameters via the keypad with control power supplied in this way, even though the drive itself is not powered. However it is NOT possible to drive the motor.

To allow this capability, the inverter does not block current inflow to the control inputs. When two or more inverters are connected together with common I/O wiring in this way, it may result in unwanted activation of inputs. The use of diodes (rated 50V, 0.1A) as shown will avoid this problem.

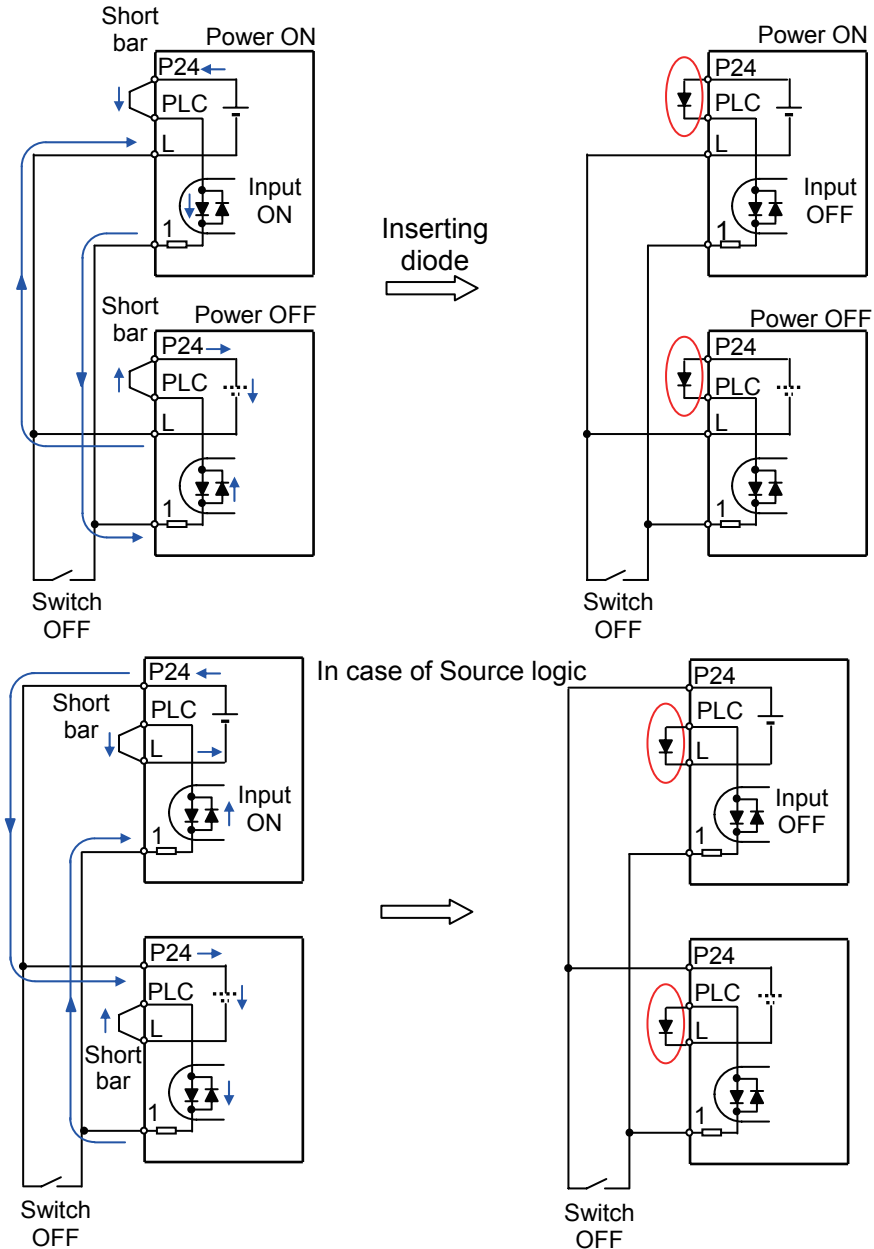

## Forward Run/Stop and Reverse Run/Stop Commands:

When you input the Run command via the terminal [FW], the inverter executes the Forward Run command (high) or Stop command (low). When you input the Run command via the terminal [RV], the inverter executes the Reverse Run command (high) or Stop command (low).

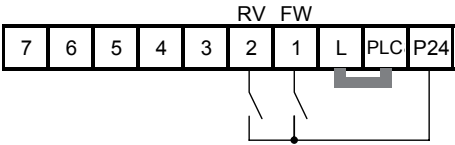
Option Code	Terminal Symbol	Function Name	State	Description
00	FW	Forward Run/Stop	ON	Inverter is in Run Mode, motor runs forward
			OFF	Inverter is in Stop Mode, motor stops
01	RV	Reverse Run/Stop	ON	Inverter is in Run Mode, motor runs reverse
			OFF	Inverter is in Stop Mode, motor stops
<b>Valid for inputs:</b>		C00 1~C007		Example (default input configuration shown see <a href="#">page 59</a> ):
<b>Required settings</b>		A002 = 01		
<b>Notes:</b> <ul style="list-style-type: none"> <li>When the Forward Run and Reverse Run commands are active at the same time, the inverter enters the Stop Mode.</li> <li>When a terminal associated with either [FW] or [RV] function is configured for <i>normally closed</i>, the motor starts rotation when that terminal is disconnected or otherwise has no input voltage.</li> </ul>				
				 <p>See I/O specs on <a href="#">page 16,17</a>.</p>



**NOTE:** The parameter **F004**, Keypad Run Key Routing, determines whether the single Run key issues a Run FWD command or Run REV command. However, it has no effect on the [FW] and [RV] input terminal operation.



**WARNING:** If the power is turned ON and the Run command is already active, the motor starts rotation and is dangerous! Before turning power ON, confirm that the Run command is not active.

## Multi-Speed Select ~Binary Operation

The inverter can store up to 16 different target frequencies (speeds) that the motor output uses for steady-state run condition. These speeds are accessible through programming four of the intelligent terminals as binary-encoded inputs CF1 to CF4 per the table to the right. These can be any of the six inputs, and in any order. You can use fewer inputs if you need eight or fewer speeds.

Multi-speed	Input Function			
	CF4	CF3	CF2	CF1
Speed 0	0	0	0	0
Speed 1	0	0	0	1
Speed 2	0	0	1	0
Speed 3	0	0	1	1
Speed 4	0	1	0	0
Speed 5	0	1	0	1
Speed 6	0	1	1	0
Speed 7	0	1	1	1
Speed 8	1	0	0	0
Speed 9	1	0	0	1
Speed 10	1	0	1	0
Speed 11	1	0	1	1
Speed 12	1	1	0	0
Speed 13	1	1	0	1
Speed 14	1	1	1	0
Speed 15	1	1	1	1



**NOTE:** When choosing a subset of speeds to use, always start at the top of the table, and with the least-significant bit: CF1, CF2, etc.

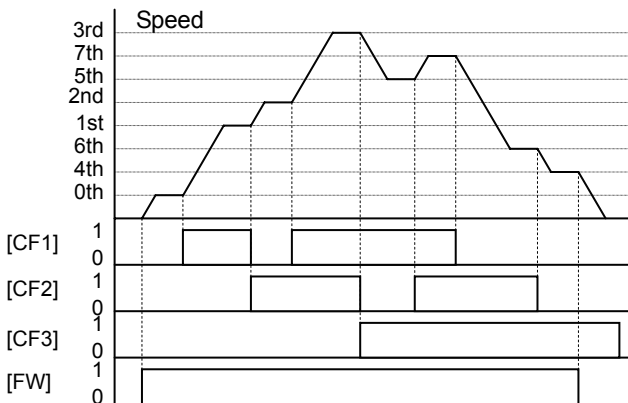

The example with eight speeds in the figure below shows how input switches configured for CF1–CF3 functions can change the motor speed in real time.

**NOTE:** Speed 0 depends on **ADD 1** parameter value.

Option Code	Terminal Symbol	Function Name	State	Description
<b>02</b>	CF1	Multi-speed Select, Bit 0 (LSB)	ON	Binary encoded speed select, Bit 0, logical 1
			OFF	Binary encoded speed select, Bit 0, logical 0
<b>03</b>	CF2	Multi-speed Select, Bit 1	ON	Binary encoded speed select, Bit 1, logical 1
			OFF	Binary encoded speed select, Bit 1, logical 0
<b>04</b>	CF3	Multi-speed Select, Bit 2	ON	Binary encoded speed select, Bit 2, logical 1
			OFF	Binary encoded speed select, Bit 2, logical 0
<b>05</b>	CF4	Multi-speed Select, Bit 3 (MSB)	ON	Binary encoded speed select, Bit 3, logical 1
			OFF	Binary encoded speed select, Bit 3, logical 0
<b>Valid for inputs:</b>		<b>C00 1~C007</b>		Example (some CF inputs require input configuration; some are default inputs):
<b>Required settings</b>		<b>F00 1, A00 1=02, A020 to A035</b>		
<b>Notes:</b>				
<ul style="list-style-type: none"> <li>When programming the multi-speed settings, be sure to press the SET key each time and then set the next multi-speed setting. Note that when the key is not pressed, no data will be set.</li> <li>When a multi-speed setting more than 50Hz (60Hz) is to be set, it is necessary to program the maximum frequency <b>A004</b> high enough to allow that speed</li> </ul>				
<p>The diagram shows a terminal block with terminals 7, 6, 5, 4, 3, 2, 1, L, PLC, and P24. Terminals 4, 3, 2, and 1 are connected to switches labeled CF4, CF3, CF2, and CF1 respectively. Terminal L is connected to a terminal labeled PLC. Terminal P24 is also connected to the PLC terminal.</p>				
See I/O specs on <a href="#">page 16,17</a> .				

## Two Stage Acceleration and Deceleration

When terminal [2CH] is turned ON, the inverter changes the rate of acceleration and deceleration from the initial settings (**F002** and **F003**) to use the second set of acceleration/ deceleration values. When the terminal is turned OFF, the inverter is returned to the original acceleration and deceleration time (**F002** acceleration time 1, and **F003** deceleration time 1). Use **A092** (acceleration time 2) and **A093** (deceleration time 2) to set the second stage acceleration and deceleration times.

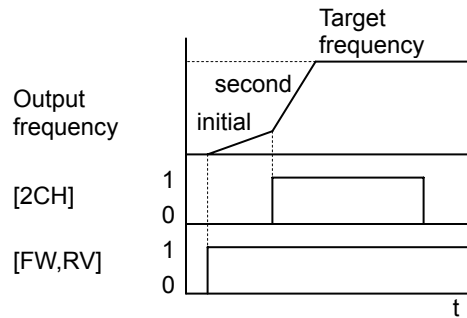

In the graph shown above, the [2CH] becomes active during the initial acceleration. This causes the inverter to switch from using acceleration 1 (**F002**) to acceleration 2 (**A092**).

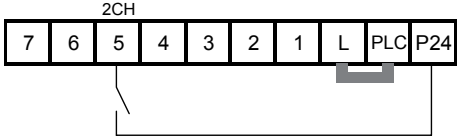
Option Code	Terminal Symbol	Function Name	State	Description
<b>09</b>	2CH	Two-stage Acceleration and Deceleration	ON	Frequency output uses 2nd-stage acceleration and deceleration values
			OFF	Frequency output uses the initial acceleration 1 and deceleration 1 values
<b>Valid for inputs:</b>		<b>C00 1~C007</b>	Example (default input configuration shown see <a href="#">page 59</a> ): 	
<b>Required settings</b>		<b>A092, A093, A094=00</b>		
<b>Notes:</b>		<ul style="list-style-type: none"> <li>Function <b>A094</b> selects the method for second stage acceleration. It must be set = <b>00</b> to select the input terminal method in order for the [2CH] terminal assignment to operate.</li> </ul>		
See I/O specs on <a href="#">page 16,17</a> .				

## Unattended Start Protection

If the Run command is already set when power is turned ON, the inverter starts running immediately after powerup. The Unattended Start Protection (USP) function prevents that automatic startup, so that the inverter *will not* run without outside intervention. When USP is active and you need to reset an alarm and resume running, either turn the Run command OFF, or perform a reset operation by the terminal [RS] input or the keypad Stop/reset key.

In the figure below, the [USP] feature is enabled. When the inverter power turns ON, the motor does not start, even though the Run command is already active. Instead, it enters the USP trip state, and displays **E 13** error code. This requires outside intervention to reset the alarm by turning OFF the Run command per this example (or applying a reset). Then the Run command can turn ON again and start the inverter output.

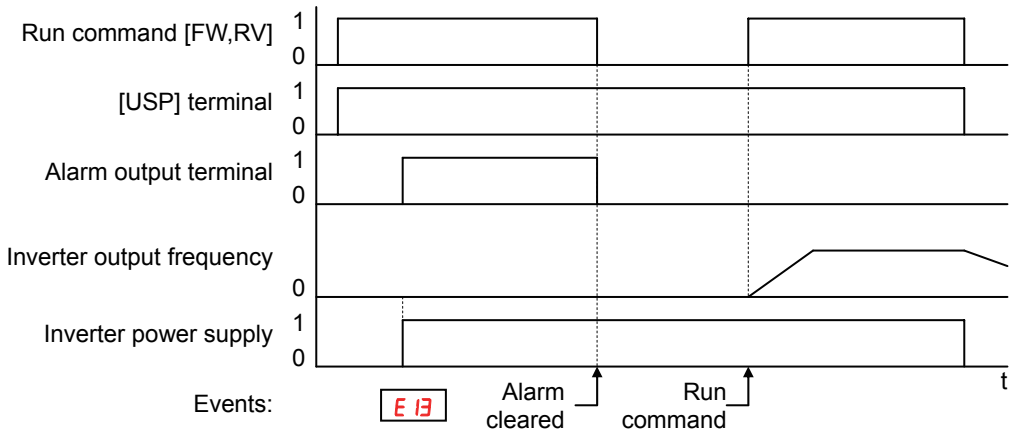

Option Code	Terminal Symbol	Function Name	State	Description
<b>13</b>	USP	Unattended Start Protection	ON	On powerup, the inverter will not resume a Run command (mostly used in the US)
			OFF	On powerup, the inverter will resume a Run command that was active before power loss
<b>Valid for inputs:</b>		<b>C001~C007</b>	Example (default input configuration shown see page 59):	
<b>Required settings</b>		(none)		
<b>Notes:</b> <ul style="list-style-type: none"> <li>Note that when a USP error occurs and it is canceled by a reset from a [RS] terminal input, the inverter restarts running immediately.</li> <li>Even when the trip state is canceled by turning the terminal [RS] ON and OFF after an under voltage protection <b>E09</b> occurs, the USP function will be performed.</li> <li>When the running command is active immediately after the power is turned ON, a USP error will occur. When this function is used, wait for at least three (3) seconds after the powerup to generate a Run command.</li> </ul>				
<p>See I/O specs on <a href="#">page 16,17</a>.</p>				

## Reset Inverter

The [RS] terminal causes the inverter to execute the reset operation. If the inverter is in Trip Mode, the reset cancels the Trip state. When the signal [RS] is turned ON and OFF, the inverter executes the reset operation. The minimum pulse width for [RS] must be 12 ms or greater. The alarm output will be cleared within 30 ms after the onset of the Reset command.

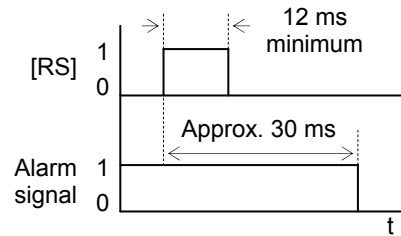

**WARNING:** After the Reset command is given and the alarm reset occurs, the motor will restart suddenly if the Run command is already active. Be sure to set the alarm reset after verifying that the Run command is OFF to prevent injury to personnel.

Option Code	Terminal Symbol	Function Name	State	Description
I8	RS	Reset Inverter	ON	The motor output is turned OFF, the Trip Mode is cleared (if it exists), and powerup reset is applied
			OFF	Normal power ON operation
<b>Valid for inputs:</b>		C00 I~C007	Example (default input configuration shown see <a href="#">page 59</a> ):	
<b>Required settings</b>		(none)		
<p><b>Notes:</b></p> <ul style="list-style-type: none"> <li>While the control terminal [RS] input is ON, the keypad displays alternating segments. After RS turns OFF, the display recovers automatically.</li> <li>Pressing the Stop/Reset key of the digital operator can generate a reset operation only when an alarm occurs.</li> </ul>				
<p>See I/O specs on <a href="#">page 16,17</a>.</p>				
<ul style="list-style-type: none"> <li>A terminal configured with the [RS] function can only be configured for normally open operation. The terminal cannot be used in the normally closed contact state.</li> <li>When input power is turned ON, the inverter performs the same reset operation as it does when a pulse on the [RS] terminal occurs.</li> <li>The Stop/Reset key on the inverter is only operational for a few seconds after inverter powerup when a hand-held remote operator is connected to the inverter.</li> <li>If the [RS] terminal is turned ON while the motor is running, the motor will be free running (coasting).</li> <li>If you are using the output terminal OFF delay feature (any of <a href="#">C 145</a>, <a href="#">C 147</a>, <a href="#">C 149</a> &gt; 0.0 sec.), the [RS] terminal affects the ON-to-OFF transition slightly. Normally (without using OFF delays), the [RS] input causes the motor output and the logic outputs to turn OFF together, immediately. However, when any output uses an OFF delay, then after the [RS] input turns ON, that output will remain ON for an additional 1 sec. period (approximate) before turning OFF.</li> </ul>				

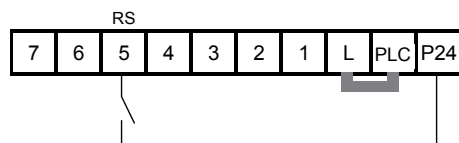

# Using Intelligent Output Terminals

## Run Signal

When the [RUN] signal is selected as an intelligent output terminal, the inverter outputs a signal on that terminal when it is in Run Mode. The output logic is active low, and is the open collector type (switch to ground).

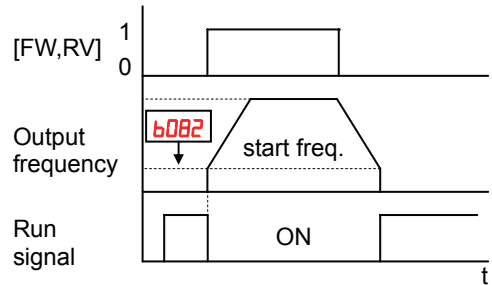

Option Code	Terminal Symbol	Function Name	State	Description
<b>00</b>	RUN	Run Signal	ON	when inverter is in Run Mode
			OFF	when inverter is in Stop Mode
<b>Valid for inputs:</b>		11, 12, AL0 – AL2		Example for terminal [11] (default output configuration shown see <a href="#">page 59</a> ):
<b>Required settings</b>		(none)		
<p><b>Notes:</b></p> <ul style="list-style-type: none"> <li>The inverter outputs the [RUN] signal whenever the inverter output exceeds the start frequency specified by parameter <b>b002</b>. The start frequency is the initial inverter output frequency when it turns ON.</li> <li>The example circuit for terminal [11] drives a relay coil. Note the use of a diode to prevent the negative going turn-off spike generated by the coil from damaging the inverter's output transistor.</li> </ul>				
<p>Example for terminal [AL0], [AL1], [AL2] (requires output configuration see <a href="#">page 59</a>):</p> <p>The diagram shows an inverter logic circuit board with three terminals labeled AL0, AL1, and AL2. These terminals are connected to a power supply and a load. The RUN signal is also shown as an output from the board.</p>				
See I/O specs on <a href="#">page 16,17</a> .				

## Frequency Arrival Signals

The *Frequency Arrival* group of outputs helps coordinate external systems with the current velocity profile of the inverter. As the name implies, output [FA1] turns ON when the output frequency arrives at the standard set frequency (parameter F001). Output [FA2] relies on programmable accel/ decel thresholds for increased flexibility. For example, you can have an output turn ON at one frequency during acceleration, and have it turn OFF at a different frequency during deceleration. All transitions have hysteresis to avoid output chatter if the output frequency is near one of the thresholds.

Option Code	Terminal Symbol	Function Name	State	Description
01	FA1	Frequency Arrival Type 1 – Constant Speed	ON	when output to motor is at the constant frequency
			OFF	when output to motor is OFF, or in any acceleration or deceleration ramp
02	FA2	Frequency Arrival Type 2 – Over frequency	ON	when output to motor is at or above the set frequency thresholds for, even if in acceleration or decel ramps
			OFF	when output to motor is OFF, or during accel or decel before the respective thresholds are crossed
06	FA3	Frequency Arrival Type 3 – Set frequency	ON	when output to motor is at the set frequency
			OFF	when output to motor is OFF, or in any acceleration or deceleration ramp
24	FA4	Frequency Arrival Type 4 – Over frequency (2)	ON	when output to motor is at or above the set frequency thresholds for, even if in acceleration or decel ramps
			OFF	when output to motor is OFF, or during accel or decel before the respective thresholds are crossed
25	FA5	Frequency Arrival Type 5 – Set frequency (2)	ON	when output to motor is at the set frequency
			OFF	when output to motor is OFF, or in any acceleration or deceleration ramp

**Valid for inputs:** 11, 12, AL0 – AL2  
**Required settings:** C042, C043, C045, C046,

Example for terminal [11] (default output configuration shown see page 59):

**Notes:**

- For most applications you will need to use only one type of frequency arrival outputs (see examples). However, it is possible assign both output terminals to output functions [FA1] and [FA2]
- For each frequency arrival threshold, the output anticipates the threshold (turns ON early) by 1.5Hz
- The output turns OFF as the output frequency moves away from the threshold, delayed by 0.5Hz
- The example circuit for terminal [11] drives a relay coil. Note the use of a diode to prevent the negative going turn-off spike generated by the coil from damaging the inverter's output transistor

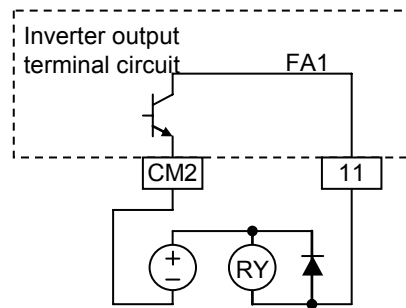

Example for terminal [AL0], [AL1], [AL2] (requires output configuration see page 59):

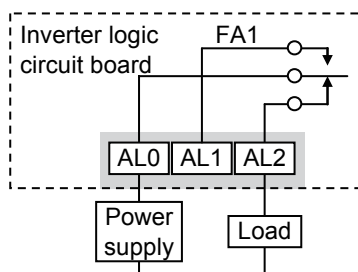

See I/O specs on page 16,17.



Frequency arrival output [FA1] uses the standard output frequency (parameter F001) as the threshold for switching. In the figure to the right, Frequency Arrival [FA1] turns ON when the output frequency gets within  $F_{on}$  Hz below or  $F_{on}$  Hz above the target constant frequency, where  $F_{on}$  is 1% of the set maximum frequency and  $F_{off}$  is 2% of the set maximum frequency. This provides hysteresis that prevents output chatter near the threshold value. The hysteresis effect causes the output to turn ON slightly *early* as the speed approaches the threshold. Then the turn-OFF point is slightly *delayed*. Note the active low nature of the signal, due to the open collector output.

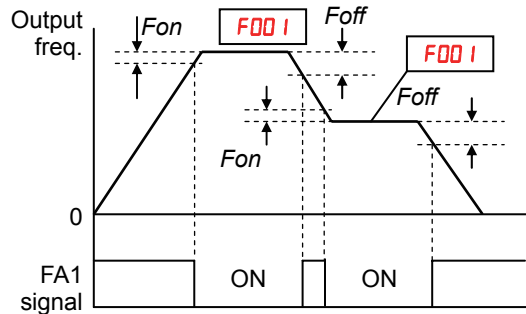

$F_{on}$ =1% of max. frequency  
 $F_{off}$ =2% of max. frequency

Frequency arrival output [FA2/FA4] works the same way; it just uses two separate thresholds as shown in the figure to the right. These provide for separate acceleration and deceleration thresholds to provide more flexibility than for [FA1]. [FA2/FA4] uses C042/C045 during acceleration for the ON threshold, and C043/C046 during deceleration for the OFF threshold. This signal also is active low. Having different accel and decel thresholds provides an asymmetrical output function. However, you can use equal ON and OFF thresholds, if desired.

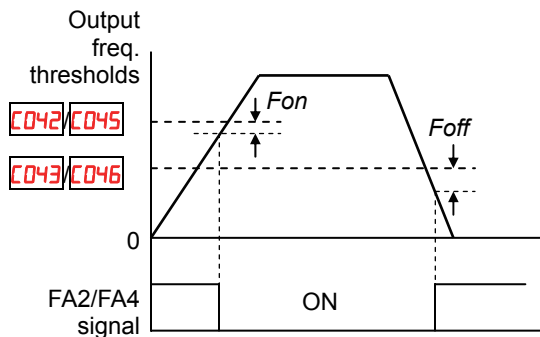

$F_{on}$ =1% of max. frequency  
 $F_{off}$ =2% of max. frequency

Frequency arrival output [FA3/FA5] works also the same way, only difference is arriving at set frequency.

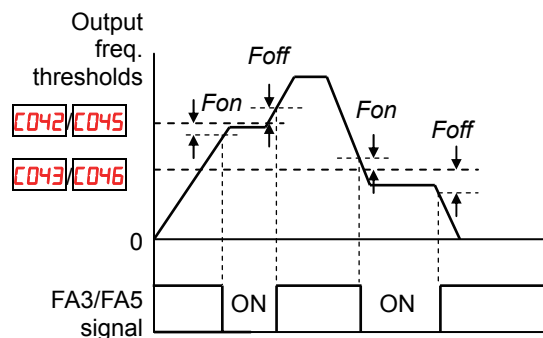

$F_{on}$ =1% of max. frequency  
 $F_{off}$ =2% of max. frequency

# Alarm Signal

The inverter alarm signal is active when a fault has occurred and it is in the Trip Mode (refer to the diagram at right). When the fault is cleared the alarm signal becomes inactive.

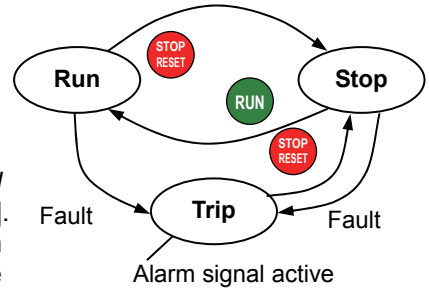

We must make a distinction between the alarm *signal* AL and the alarm relay *contacts* [AL0], [AL1] and [AL2]. The signal AL is a logic function, which you can assign to the open collector output terminals [11], [12], or the relay outputs.

The most common (and default) use of the relay is for AL, thus the labeling of its terminals. Use an open collector output (terminal [11] or [12]) for a low-current logic signal interface or to energize a small relay (50 mA maximum). Use the relay output to interface to higher voltage and current devices (10 mA minimum).

Option Code	Terminal Symbol	Function Name	State	Description
05	AL	Alarm Signal	ON	when an alarm signal has occurred and has not been cleared
			OFF	when no alarm has occurred since the last clearing of alarm(s)
<b>Valid for inputs:</b>		11, 12, AL0 – AL2		Example for terminal [11] (default output configuration shown see page 59):
<b>Required settings</b>		C031, C032, C036		
<p><b>Notes:</b></p> <ul style="list-style-type: none"> <li>By default, the relay is configured as normally closed (C036=01). Refer to the next page for an explanation.</li> <li>In the default relay configuration, an inverter power loss turns ON the alarm output. the alarm signal remains ON as long as the external control circuit has power.</li> <li>When the relay output is set to normally closed, a time delay of less than 2 seconds occurs after powerup before the contact is closed.</li> <li>Terminals [11] and [12] are open collector outputs, so the electric specifications of [AL] are different from the contact output terminals [AL0], [AL1], [AL2].</li> <li>This signal output has the delay time (300 ms nominal) from the fault alarm output.</li> <li>The relay contact specifications are in “Control Logic Signal Specifications” on page 4–6. The contact diagrams for different conditions are on the next page.</li> </ul>				
<p>Example for terminal [AL0], [AL1], [AL2] (requires output configuration see page 59):</p>				
See I/O specs on <a href="#">page 16,17</a> .				

The alarm relay output can be configured in two main ways:

- Trip/Power Loss Alarm** – The alarm relay is configured as normally closed ( $C036=01$ ) by default, shown below (left). An external alarm circuit that detects broken wiring also as an alarm connects to [AL0] and [AL1]. After powerup and short delay (< 2 seconds), the relay energizes and the alarm circuit is OFF. Then, either an inverter trip event or an inverter power loss will de-energize the relay and open the alarm circuit
- Trip Alarm** – Alternatively, you can configure the relay as normally open ( $C036=00$ ), shown below (right). An external alarm circuit that detects broken wiring also as an alarm connects to [AL0] and [AL2]. After powerup, the relay energizes only when an inverter trip event occurs, opening the alarm circuit. However, in this configuration, an inverter power loss does not open the alarm circuit.

Be sure to use the relay configuration that is appropriate for your system design. Note that the external circuits shown assume that a closed circuit = no alarm condition (so that a broken wire also causes an alarm). However, some systems may require a closed circuit = alarm condition. In that case, then use the opposite terminal [AL1] or [AL2] from the ones shown.

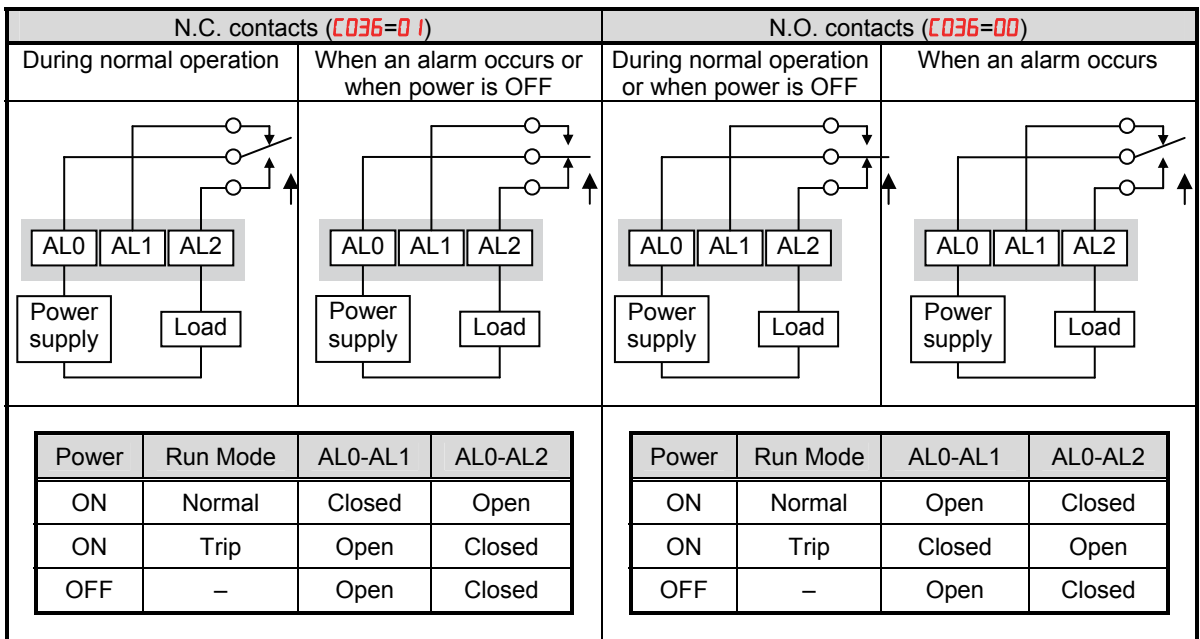

# Analog Input Operation

The WJ200 inverters provide for analog input to command the inverter frequency output value. The analog input terminal group includes the [L], [OI], [O], and [H] terminals on the control connector, which provide for Voltage [O] or Current [OI] input. All analog input signals must use the analog ground [L].

If you use either the voltage or current analog input, you must select one of them using the logic input terminal function [AT] analog type. Refer to the table on next page showing the activation of each analog input by combination of **ADD5** set parameter and [AT] terminal condition. The [AT] terminal function is covered in “Analog Input Current/Voltage Select” in section 4. Remember that you must also set **ADD1 = 01** to select analog input as the frequency source.

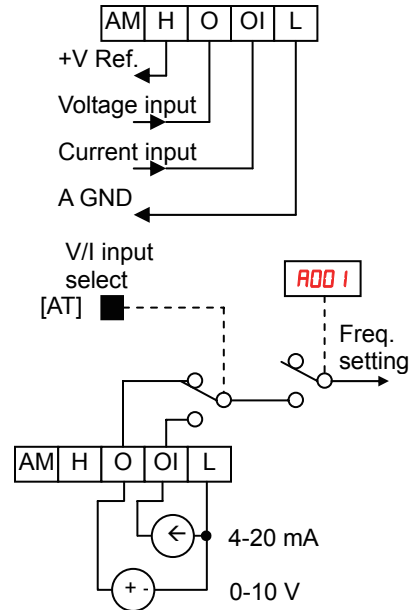

**NOTE:** If no logic input terminal is configured for the [AT] function, then inverter recognizes that [AT]=OFF and MCU recognizes [O]+[OI] as analog input.

Using an external potentiometer is a common way to control the inverter output frequency (and a good way to learn how to use the analog inputs). The potentiometer uses the built-in 10V reference [H] and the analog ground [L] for excitation, and the voltage input [O] for the signal. By default, the [AT] terminal selects the voltage input when it is OFF. Take care to use the proper resistance for the potentiometer, which is 1~2 kΩ, 2 Watts.

**Voltage Input** – The voltage input circuit uses terminals [L] and [O]. Attach the signal cable’s shield wire only to terminal [L] on the inverter. Maintain the voltage within specifications (do not apply negative voltage).

**Current Input** – The current input circuit uses terminals [OI] and [L]. The current comes from a *sourcing* type transmitter; a *sinking* type will not work! This means the current must flow into terminal [OI], and terminal [L] is the return back to the transmitter. The input impedance from [OI] to [L] is 100 Ohms. Attach the cable shield wire only to terminal [L] on the inverter.

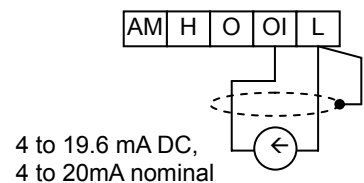
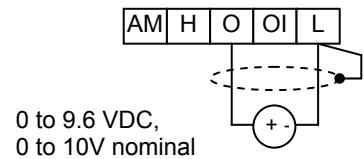
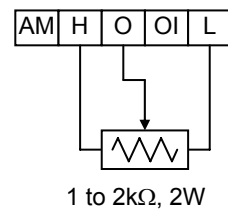

See I/O specs on page 21,22.

The following table shows the available analog input settings. Parameter **A005** and the input terminal [AT] determine the External Frequency Command input terminals that are available, and how they function. The analog inputs [O] and [OI] use terminal [L] as the reference (signal return).

<b>A005</b>	[AT] Input	Analog Input Configuration
<b>00</b>	ON	[OI]
	OFF	[O]
<b>02</b>	ON	Integrated POT on external panel
	OFF	[O]
<b>03</b>	ON	Integrated POT on external panel
	OFF	[OI]

**Other Analog Input-related topics:**

- “Analog Input Settings”
- “Additional Analog Input Settings”
- “Analog Signal Calibration Settings”
- “Analog Input Current/Voltage Select”
- “ADD Frequency Enable”
- “Analog Input Disconnect Detect”

# Pulse Train Input Operation

The WJ200 inverter is capable of accepting pulse train input signals, that are used for frequency command, process variable (feedback) for PID control, and simple positioning. The dedicated terminal is called “EA” and “EB”. Terminal “EA” is a dedicated terminal, and the terminal “EB” is an intelligent terminal, that has to be changed by a parameter setting.

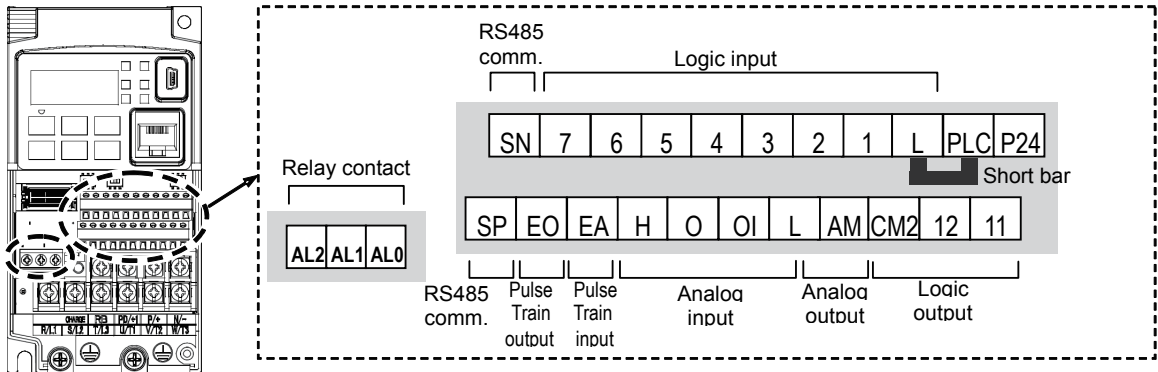

Terminal Name	Description	Ratings
EA	Pulse train input A	For frequency command, 32kHz max. Reference voltage: Common is [L]
EB (Input terminal 7)	Pulse train input B (Set <b>C007</b> to <b>B5</b> )	27Vdc max. For frequency command, 2kHz max. Reference voltage: Common is [PLC]

## (1) Frequency Command by pulse train input

When using this mode, you should set **A001** to **06**. In this case the frequency is detected by input-capture, and calculated based on the ratio of designated max. frequency (under 32kHz). Only an input terminal “EA” will be used in this case.

## (2) Using for process variable of PID control

You can use the pulse train input for process variable (feedback) of PID control. In this case you need to set **A076** to **03**. Only “EA” input terminal is to be used.

## (3) Simple positioning by pulse train input

This is to use the pulse train input like an encoder signal. You can select three types of operation.

# Analog Output Operation

In inverter applications it is useful to monitor the inverter operation from a remote location or from the front panel of an inverter enclosure. In some cases, this requires only a panel-mounted volt meter. In other cases, a controller such as a PLC may provide the inverter's frequency command, and require inverter feedback data (such as output frequency or output current) to confirm actual operation. The analog output terminal [AM] serves these purposes.

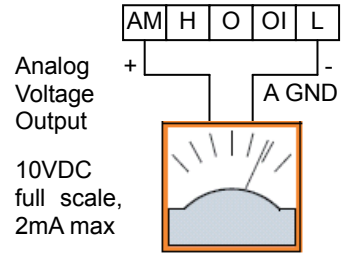

See I/O specs on page 21,22

The inverter provides an analog voltage output on terminal [AM] with terminal [L] as analog GND reference. The [AM] can output inverter frequency or current output value. Note that the voltage range is 0 to +10V (positive-going only), regardless of forward or reverse motor rotation. Use **C028** to configure terminal [AM] as indicated below.

Func.	Code	Description
<b>C028</b>	<b>00</b>	Inverter output frequency
	<b>01</b>	Inverter output current
	<b>02</b>	Inverter output torque
	<b>03</b>	Digital output frequency
	<b>04</b>	Inverter output voltage
	<b>05</b>	Inverter input power
	<b>06</b>	Electronic Thermal Load
	<b>07</b>	LAD frequency
	<b>08</b>	Digital current monitor
	<b>10</b>	Cooling fin temperature
	<b>12</b>	General purpose
	<b>15</b>	Pulse train
	<b>16</b>	Option

The [AM] signal offset and gain are adjustable, as indicated below.

Func.	Description	Range	Default
<b>C 106</b>	[AM] output gain	0~255.	100.
<b>C 109</b>	[AM] output offset	0.0~10.0	0.0

The graph below shows the effect of the gain and offset setting. To calibrate the [AM] output for your application (analog meter), follow the steps below:

1. Run the motor at the full scale speed, or most common operating speed.
  - a. If the analog meter represents output frequency, adjust offset (**C 109**) first, and then use **C 106** to set the voltage for full scale output.
  - b. If [AM] represents motor current, adjust offset (**C 109**) first, and then use **C 106** to set the voltage for full scale output. Remember to leave room at the upper end of the range for increased current when the motor is under heavier loads.

AM output offset adjustment

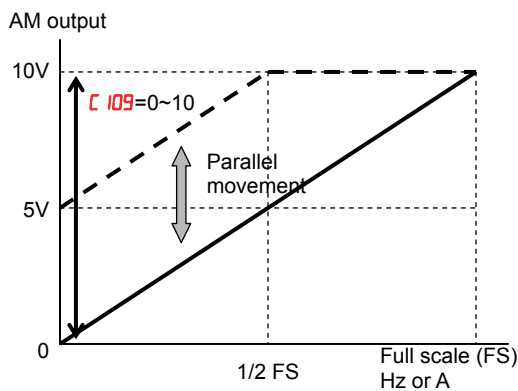

AM output gain adjustment

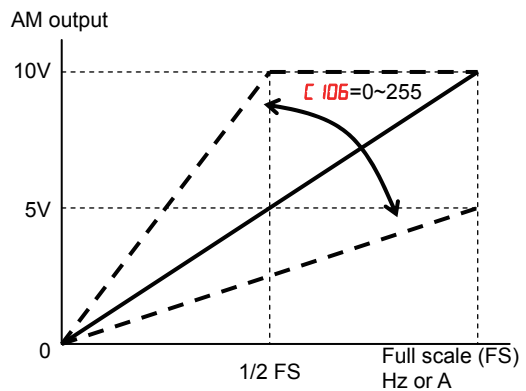

**NOTE:** As mentioned above, first adjust the offset, and then adjust the gain. Otherwise the required performance cannot be obtained because of the parallel movement of the offset adjustment.



## Monitoring functions

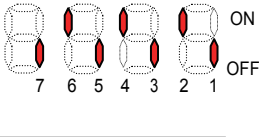
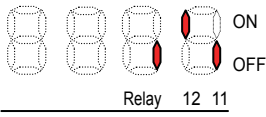

**NOTE:** Mark “✓” in b031=10 shows the accessible parameters when b031 is set “10”, high level access.

“d” Function			Run Mode Edit	Units
Func. Code	Name	Description		
d001	Output frequency monitor	Real time display of output frequency to motor from 0.0 to 400.0Hz If <b>b163</b> is set high, output frequency ( <b>F001</b> ) can be changed by up/down key with d001 monitoring.	–	Hz
d002	Output current monitor	Filtered display of output current to motor, range is 0 to 655.3 ampere (~99.9 ampere for 1.5kW and less)	–	A
d003	Rotation direction monitor	Three different indications: “F” ... Forward “o” ... Stop “r” ... Reverse	–	–
d004	Process variable (PV), PID feedback monitor	Displays the scaled PID process variable (feedback) value ( <b>F075</b> is scale factor), 0.00 to 10000	–	% times constant
d005	Intelligent input terminal status	Displays the state of the intelligent input terminals:  Terminal numbers	–	–
d006	Intelligent output terminal status	Displays the state of the intelligent output terminals:  Relay 12 11	–	–

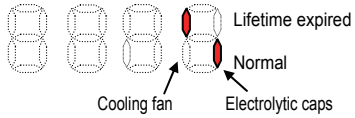
"d" Function				Run Mode Edit	Units
Func. Code	Name	Description			
d007	Scaled output frequency monitor	Displays the output frequency scaled by the constant in <b>b086</b> . Decimal point indicates range: 0 to 3999	-		Hz times constant
d008	Actual frequency monitor	Displays the actual frequency, range is -400 to 400 Hz	-		Hz
d009	Torque command monitor	Displays the torque command, range is -200 to 200 %	-		%
d010	Torque bias monitor	Displays the torque bias value, range is -200 to 200 %	-		%
d012	Output torque monitor	Displays the output torque, range is -200 to 200 %	-		%
d013	Output voltage monitor	Voltage of output to motor, Range is 0.0 to 600.0V	-		V
d014	Input power monitor	Displays the input power, range is 0 to 999.9 kW	-		KW
d015	Watt-hour monitor	Displays watt-hour of the inverter, range is 0 to 9999000	-		
d016	Elapsed RUN time monitor	Displays total time the inverter has been in RUN mode in hours. Range is 0 to 9999 / 1000 to 9999 / $\lceil 100$ to $\lceil 999$ (10,000 to 99,900)	-		hours
d017	Elapsed power-on time monitor	Displays total time the inverter has been powered up in hours. Range is 0 to 9999 / 1000 to 9999 / $\lceil 100$ to $\lceil 999$ (10,000 to 99,900)	-		hours
d018	Heat sink temperature monitor	Temperature of the cooling fin, range is -20~150	-		°C
d022	Life check monitor	Displays the state of lifetime of electrolytic capacitors on the PWB and cooling fan. 	-		-
d023	Program counter monitor [EzSQ]	Range is 0 to 1024	-		-
d024	Program number monitor [EzSQ]	Range is 0 to 9999	-		-
d025	User monitor 0 [EzSQ]	Result of EzSQ execution, range is -2147483647~2147483647	-		-
d026	User monitor 1 [EzSQ]	Result of EzSQ execution, range is -2147483647~2147483647	-		-
d027	User monitor 2 [EzSQ]	Result of EzSQ execution, range is -2147483647~2147483647	-		-
d029	Positioning command monitor	Displays the positioning command, range is -268435455~+268435455	-		-
d030	Current position monitor	Displays the current position, range is -268435455~+268435455	-		-
d050	Dual monitor	Displays two different data configured in <b>b160</b> and <b>b161</b> .	-		-
d060	Inverter mode monitor	Displays currently selected inverter mode : I-C:IM CT mode/I-v:IM VT mode/ P:PM	-		-

"d" Function			Run Mode Edit	Units
Func. Code	Name	Description		
d080	Trip counter	Number of trip events, Range is 0. to 65530	-	events
d081	Trip monitor 1	Displays trip event information: <ul style="list-style-type: none"> <li>Error code</li> <li>Output frequency at trip point</li> <li>Motor current at trip point</li> <li>DC bus voltage at trip point</li> <li>Cumulative inverter operation time at trip point</li> <li>Cumulative power-ON time at trip point</li> </ul>	-	-
d082	Trip monitor 2		-	-
d083	Trip monitor 3		-	-
d084	Trip monitor 4		-	-
d085	Trip monitor 5		-	-
d086	Trip monitor 6		-	-
d090	Warning monitor	Displays the warning code	-	-
d102	DC bus voltage monitor	Voltage of inverter internal DC bus, Range is 0.0 to 999.9	-	V
d103	BRD load ratio monitor	Usage ratio of integrated brake chopper, range is 0.0~100.0%	-	%
d104	Electronic thermal monitor	Accumulated value of electronic thermal detection, range is from 0.0~100.0%	-	%

## Main Profile Parameters



**NOTE:** Mark "✓" in b031=10 shows the accessible parameters when b031 is set "10", high level access.

"F" Function			Run Mode Edit	Defaults	
Func. Code	Name	Description		Initial data	Units
F001	Output frequency setting	Standard default target frequency that determines constant motor speed, range is 0.0 / start frequency to maximum frequency (A004)	✓	0.0	Hz
F002	Acceleration time (1)	Standard default acceleration, range is 0.01 to 3600 sec.	✓	10.0	sec.
F202	Acceleration time (1), 2 <sup>nd</sup> motor		✓	10.0	sec.
F003	Deceleration time (1)	Standard default deceleration, range is 0.01 to 3600 sec.	✓	10.0	sec.
F203	Deceleration time (1), 2 <sup>nd</sup> motor		✓	10.0	sec.
F004	Keypad RUN key routing	Two options; select codes: 00 ...Forward 01 ...Reverse	✗	00	-

## Standard Functions



**NOTE:** Mark “✓” in b031=10 shows the accessible parameters when b031 is set “10”, high level access.

“A” Function			Run Mode Edit	Defaults	
Func. Code	Name	Description		Initial data	Units
<i>A001</i>	Frequency source	Eight options; select codes: <i>00</i> ...POT on ext. operator <i>01</i> ...Control terminal	✗	02	–
<i>A201</i>	Frequency source, 2 <sup>nd</sup> motor	<i>02</i> ...Function F001 setting <i>03</i> ...ModBus network input <i>04</i> ...Option <i>06</i> ...Pulse train input <i>07</i> ...via EzSQ <i>10</i> ...Calculate function output	✗	02	–
<i>A002</i>	Run command source	Five options; select codes: <i>01</i> ...Control terminal <i>02</i> ...Run key on keypad, or digital operator	✗	02	–
<i>A202</i>	Run command source, 2 <sup>nd</sup> motor	<i>03</i> ...ModBus network input <i>04</i> ...Option	✗	02	–
<i>A003</i>	Base frequency	Settable from 30 Hz to the maximum frequency( <i>A004</i> )	✗	60.0	Hz
<i>A203</i>	Base frequency, 2 <sup>nd</sup> motor	Settable from 30 Hz to the 2 <sup>nd</sup> maximum frequency( <i>A204</i> )	✗	60.0	Hz
<i>A004</i>	Maximum frequency	Settable from the base frequency to 400 Hz	✗	60.0	Hz
<i>A204</i>	Maximum frequency, 2 <sup>nd</sup> motor	Settable from the 2 <sup>nd</sup> base frequency to 400 Hz	✗	60.0	Hz
<i>A005</i>	[AT] selection	Three options; select codes: <i>00</i> ...Select between [O] and [OI] at [AT] (ON=OI, OFF=O) <i>02</i> ...Select between [O] and external POT at [AT] (ON=POT, OFF=O) <i>03</i> ...Select between [OI] and external POT at [AT] (ON=POT, OFF=OI)	✗	00	–
<i>A011</i>	[O] input active range start frequency	The output frequency corresponding to the analog input range starting point, range is 0.00 to 400.0	✗	0.00	Hz
<i>A012</i>	[O] input active range end frequency	The output frequency corresponding to the analog input range ending point, range is 0.0 to 400.0	✗	0.00	Hz
<i>A013</i>	[O] input active range start voltage	The starting point (offset) for the active analog input range, range is 0. to 100.	✗	0.	%
<i>A014</i>	[O] input active range end voltage	The ending point (offset) for the active analog input range, range is 0. to 100.	✗	100.	%

"A" Function			Run Mode Edit	Defaults	
Func. Code	Name	Description		Initial data	Units
<i>AD15</i>	[O] input start frequency enable	Two options; select codes: <i>00</i> ...Use offset ( <i>AD11</i> value) <i>01</i> ...Use 0Hz	✗	01	–
<i>AD16</i>	Analog input filter	Range n = 1 to 31, 1 to 30 : ×2ms filter 31: 500ms fixed filter with ± 0.1kHz hys.	✗	8.	Spl.
<i>AD17</i>	Simple sequence function selection(EzSQ)	<i>00</i> ...Disable <i>01</i> ...PRG terminal <i>02</i> ...Always	✓	00	–
<i>AD19</i>	Multi-speed operation selection	Select codes: <i>00</i> ...Binary operation (16 speeds selectable with 4 terminals) <i>01</i> ...Bit operation (8 speeds selectable with 7 terminals)	✗	00	–
<i>AD20</i>	Multi-speed freq. 0	Defines the first speed of a multi-speed profile, range is 0.0 / start frequency to 400Hz <i>AD20</i> = Speed 0 (1st motor)	✓	0.0	Hz
<i>AD20</i>	Multi-speed freq. 0, 2 <sup>nd</sup> motor	Defines the first speed of a multi-speed profile or a 2nd motor, range is 0.0 / start frequency to 400Hz <i>AD20</i> = Speed 0 (2nd motor)	✓	0.0	Hz
<i>AD21</i> to <i>AD35</i>	Multi-speed freq. 1 to 15 (for both motors)	Defines 15 more speeds, range is 0.0 / start frequency to 400 Hz. <i>AD21</i> =Speed 1 ~ <i>AD35</i> =Speed15	✓	See next row	Hz
		<i>AD21</i> ~ <i>AD35</i>	✓	0.0	Hz
<i>AD38</i>	Jog frequency	Defines limited speed for jog, range is from start frequency to 9.99 Hz	✓	6.00	Hz
<i>AD39</i>	Jog stop mode	Define how end of jog stops the motor; six options: <i>00</i> ...Free-run stop (invalid during run) <i>01</i> ...Controlled deceleration (invalid during run) <i>02</i> ...DC braking to stop(invalid during run) <i>03</i> ...Free-run stop (valid during run) <i>04</i> ...Controlled deceleration (valid during run) <i>05</i> ...DC braking to stop(valid during run)	✗	04	–
<i>AD41</i>	Torque boost select	Two options: <i>00</i> ...Manual torque boost	✗	00	–
<i>AD41</i>	Torque boost select, 2 <sup>nd</sup> motor	<i>01</i> ...Automatic torque boost	✗	00	–
<i>AD42</i>	Manual torque boost value	Can boost starting torque between 0 and 20% above	✓	1.0	%

"A" Function			Run Mode Edit	Defaults	
Func. Code	Name	Description		Initial data	Units
A242	Manual torque boost value, 2 <sup>nd</sup> motor	normal V/f curve, range is 0.0 to 20.0%	✓	1.0	%
A043	Manual torque boost frequency	Sets the frequency of the V/f breakpoint A in graph (top of previous page) for torque boost, range is 0.0 to 50.0%	✓	5.0	%
A243	Manual torque boost frequency, 2 <sup>nd</sup> motor		✓	5.0	%
A044	V/f characteristic curve	Six available V/f curves; 00...Constant torque 01...Reduced torque (1.7) 02...Free V/F 03...Sensorless vector (SLV)	✗	00	–
A244	V/f characteristic curve, 2 <sup>nd</sup> motor		✗	00	–
A045	V/f gain	Sets voltage gain of the inverter, range is 20. to 100.%	✓	100.	%
A245	V/f gain, 2 <sup>nd</sup> motor		✓	100.	%
A046	Voltage compensation gain for automatic torque boost	Sets voltage compensation gain under automatic torque boost, range is 0. to 255.	✓	100.	–
A246	Voltage compensation gain for automatic torque boost, 2 <sup>nd</sup> motor		✓	100.	–
A047	Slip compensation gain for automatic torque boost	Sets slip compensation gain under automatic torque boost, range is 0. to 255.	✓	100.	–
A247	Slip compensation gain for automatic torque boost, 2 <sup>nd</sup> motor		✓	100.	–
A051	DC braking enable	Three options; select codes: 00...Disable 01...Enable during stop 02...Frequency detection	✗	00	–
A052	DC braking frequency	The frequency at which DC braking begins, range is from the start frequency (b0b2) to 60Hz	✗	0.5	Hz
A053	DC braking wait time	The delay from the end of controlled deceleration to start of DC braking (motor free runs until DC braking begins), range is 0.0 to 5.0 sec.	✗	0.0	sec.
A054	DC braking force for deceleration	Level of DC braking force, settable from 0 to 100%	✗	50.	%
A055	DC braking time for deceleration	Sets the duration for DC braking, range is from 0.0 to 60.0 seconds	✗	0.5	sec.
A056	DC braking / edge or level detection for [DB] input	Two options; select codes: 00...Edge detection 01...Level detection	✗	01	–
A057	DC braking force at start	Level of DC braking force at start, settable from 0 to 100%	✗	0.	%

"A" Function			Run Mode Edit	Defaults	
Func. Code	Name	Description		Initial data	Units
<b>A058</b>	DC braking time at start	Sets the duration for DC braking, range is from 0.0 to 60.0 seconds	✗	0.0	sec.
<b>A059</b>	Carrier frequency during DC braking	Carrier frequency of DC braking performance, range is from 2.0 to 15.0kHz	✗	5.0	sec.
<b>A061</b>	Frequency upper limit	Sets a limit on output frequency less than the maximum frequency ( <b>A004</b> ). Range is from frequency lower limit ( <b>A062</b> ) to maximum frequency ( <b>A004</b> ). 0.0 setting is disabled >0.0 setting is enabled	✗	0.00	Hz
<b>A261</b>	Frequency upper limit, 2nd motor	Sets a limit on output frequency less than the maximum frequency ( <b>A204</b> ). Range is from frequency lower limit ( <b>A262</b> ) to maximum frequency ( <b>A204</b> ). 0.0 setting is disabled >0.0 setting is enabled	✗	0.00	Hz
<b>A062</b>	Frequency lower limit	Sets a limit on output frequency greater than zero. Range is start frequency ( <b>b082</b> ) to frequency upper limit ( <b>A061</b> ) 0.0 setting is disabled >0.0 setting is enabled	✗	0.00	Hz
<b>A262</b>	Frequency lower limit, 2nd motor	Sets a limit on output frequency greater than zero. Range is start frequency ( <b>b082</b> ) to frequency upper limit ( <b>A261</b> ) 0.0 setting is disabled >0.0 setting is enabled	✗	0.00	Hz
<b>A063</b> <b>A065</b> <b>A067</b>	Jump freq. (center) 1 to 3	Up to 3 output frequencies can be defined for the output to jump past to avoid motor resonances (center frequency) Range is 0.0 to 400.0 Hz	✗	0.0 0.0 0.0	Hz
<b>A064</b> <b>A066</b> <b>A068</b>	Jump freq. width (hysteresis) 1 to 3	Defines the distance from the center frequency at which the jump around occurs Range is 0.0 to 10.0 Hz	✗	0.5 0.5 0.5	Hz
<b>A069</b>	Acceleration hold frequency	Sets the frequency to hold acceleration, range is 0.0 to 400.0Hz	✗	0.00	Hz
<b>A070</b>	Acceleration hold time	Sets the duration of acceleration hold, range is 0.0 to 60.0 seconds	✗	0.0	sec.
<b>A071</b>	PID enable	Enables PID function, three option codes: 00...PID Disable 01...PID Enable 02...PID Enable with reverse output	✗	00	-

"A" Function			Run Mode Edit	Defaults	
Func. Code	Name	Description		Initial data	Units
<i>A072</i>	PID proportional gain	Proportional gain has a range of 0.00 to 25.00	✓	1.0	–
<i>A073</i>	PID integral time constant	Integral time constant has a range of 0.0 to 3600 seconds	✓	1.0	sec.
<i>A074</i>	PID derivative time constant	Derivative time constant has a range of 0.0 to 100 seconds	✓	0.00	sec.
<i>A075</i>	PV scale conversion	Process Variable (PV), scale factor (multiplier), range of 0.01 to 99.99	✗	1.00	–
<i>A076</i>	PV source	Selects source of Process Variable (PV), option codes: 00...[OI] terminal (current in) 01...[O] terminal (voltage in) 02...ModBus network 03...Pulse train input 10...Calculate function output	✗	00	–
<i>A077</i>	Reverse PID action	Two option codes: 00...PID input = SP-PV 01...PID input = -(SP-PV)	✗	00	–
<i>A078</i>	PID output limit	Sets the limit of PID output as percent of full scale, range is 0.0 to 100.0%	✗	0.0	%
<i>A079</i>	PID feed forward selection	Selects source of feed forward gain, option codes: 00...Disabled 01...[O] terminal (voltage in) 02...[OI] terminal (current in)	✗	00	–
<i>A081</i>	AVR function select	Automatic (output) voltage regulation, selects from three type of AVR functions, three option codes:	✗	02	–
<i>A281</i>	AVR function select, 2 <sup>nd</sup> motor	00...AVR enabled 01...AVR disabled 02...AVR enabled except during deceleration	✗	02	–
<i>A082</i>	AVR voltage select	200V class inverter settings: .....200/215/220/230/240	✗	200	V
<i>A282</i>	AVR voltage select, 2 <sup>nd</sup> motor		✗	200	V
<i>A083</i>	AVR filter time constant	Define the time constant of the AVR filter, range is 0 to 10 sec.	✗	0.300	sec.
<i>A084</i>	AVR deceleration gain	Gain adjustment of the braking performance, range is 50 to 200%	✗	100.	%
<i>A085</i>	Energy-saving operation mode	Two option codes: 00...Normal operation 01...Energy-saving operation	✗	00	–
<i>A086</i>	Energy-saving mode tuning	Range is 0.0 to 100 %.	✗	50.0	%



"A" Function			Run Mode Edit	Defaults	
Func. Code	Name	Description		Initial data	Units
<i>A092</i>	Acceleration time (2)	Duration of 2 <sup>nd</sup> segment of acceleration, range is: 0.01 to 3600 sec.	✓	10.00	sec.
<i>A292</i>	Acceleration time (2), 2 <sup>nd</sup> motor		✓	10.00	sec.
<i>A093</i>	Deceleration time (2)	Duration of 2 <sup>nd</sup> segment of deceleration, range is: 0.01 to 3600 sec.	✓	10.00	sec.
<i>A293</i>	Deceleration time (2), 2 <sup>nd</sup> motor		✓	10.00	sec.
<i>A094</i>	Select method to switch to Acc2/Dec2 profile	Three options for switching from 1st to 2nd accel/decel: <i>00</i> ...2CH input from terminal <i>01</i> ...Transition frequency <i>02</i> ...Forward and reverse	✗	00	–
<i>A294</i>	Select method to switch to Acc2/Dec2 profile, 2 <sup>nd</sup> motor		✗	00	–
<i>A095</i>	Acc1 to Acc2 frequency transition point	Output frequency at which Accel1 switches to Accel2, range is 0.0 to 400.0 Hz	✗	0.0	Hz
<i>A295</i>	Acc1 to Acc2 frequency transition point, 2 <sup>nd</sup> motor		✗	0.0	Hz
<i>A096</i>	Dec1 to Dec2 frequency transition point	Output frequency at which Decel1 switches to Decel2, range is 0.0 to 400.0 Hz	✗	0.0	Hz
<i>A296</i>	Dec1 to Dec2 frequency transition point, 2 <sup>nd</sup> motor		✗	0.0	Hz
<i>A097</i>	Acceleration curve selection	Set the characteristic curve of Acc1 and Acc2, five options: <i>00</i> ...linear <i>01</i> ...S-curve <i>02</i> ...U-curve <i>03</i> ...Inverse U-curve <i>04</i> ...EL S-curve	✗	01	–
<i>A098</i>	Deceleration curve selection	Set the characteristic curve of Dec1 and Dec2, options are same as above ( <i>A097</i> )	✗	01	–
<i>A101</i>	[OI] input active range start frequency	The output frequency corresponding to the analog input range starting point, range is 0.0 to 400.0 Hz	✗	0.00	Hz
<i>A102</i>	[OI] input active range end frequency	The output frequency corresponding to the current input range ending point, range is 0.0 to 400.0 Hz	✗	0.0	Hz
<i>A103</i>	[OI] input active range start current	The starting point (offset) for the current input range, range is 0. to 100.%	✗	20.	%
<i>A104</i>	[OI] input active range end current	The ending point (offset) for the current input range, range is 0. to 100.%	✗	100.	%
<i>A105</i>	[OI] input start frequency select	Two options; select codes: <i>00</i> ...Use offset ( <i>A101</i> value) <i>01</i> ...Use 0Hz	✗	00	–

"A" Function			Run Mode Edit	Defaults	
Func. Code	Name	Description		Initial data	Units
<i>A 131</i>	Acceleration curve constant	Range is 01 to 10.	✗	02	–
<i>A 132</i>	Deceleration curve constant	Range is 01 to 10.	✗	02	–
<i>A 141</i>	A input select for calculate function	Seven options: 00...Operator 01...VR 02...Terminal [O] input 03...Terminal [OI] input 04...RS485 05...Option 07...Pulse train input	✗	02	–
<i>A 142</i>	B input select for calculate function	Seven options: 00...Operator 01...VR 02...Terminal [O] input 03...Terminal [OI] input 04...RS485 05...Option 07...Pulse train input	✗	03	–
<i>A 143</i>	Calculation symbol	Calculates a value based on the A input source ( <i>A 141</i> selects) and B input source ( <i>A 142</i> selects). Three options: 00...ADD (A input + B input) 01...SUB (A input - B input) 02...MUL (A input * B input)	✗	00	–
<i>A 145</i>	ADD frequency	An offset value that is applied to the output frequency when the [ADD] terminal is ON. Range is 0.0 to 400.0 Hz	✓	0.00	Hz
<i>A 146</i>	ADD direction select	Two options: 00...Plus (adds <i>A 145</i> value to the output frequency setting) 01...Minus (subtracts <i>A 145</i> value from the output frequency setting)	✗	00	–
<i>A 150</i>	Curvature of EL-S-curve at the start of acceleration	Range is 0 to 50%	✗	10.	%
<i>A 151</i>	Curvature of EL-S-curve at the end of acceleration	Range is 0 to 50%	✗	10.	%
<i>A 152</i>	Curvature of EL-S-curve at the start of deceleration	Range is 0 to 50%	✗	10.	%
<i>A 153</i>	Curvature of EL-S-curve at the end of deceleration	Range is 0 to 50%	✗	10.	%
<i>A 154</i>	Deceleration hold frequency	Sets the frequency to hold deceleration, range is 0.0 to 400.0Hz	✗	0.0	Hz
<i>A 155</i>	Deceleration hold time	Sets the duration of deceleration hold, range is 0.0 to 60.0 seconds	✗	0.0	sec.

"A" Function			Run Mode Edit	Defaults	
Func. Code	Name	Description		Initial data	Units
<b>A 156</b>	PID sleep function action threshold	Sets the threshold for the action, set range 0.0~400.0 Hz	✘	0.00	Hz
<b>A 157</b>	PID sleep function action delay time	Sets the delay time for the action, set range 0.0~25.5 sec	✘	0.0	sec.
<b>A 161</b>	[VR] input active range start frequency	The output frequency corresponding to the analog input range starting point, range is 0.0 to 400.0 Hz	✘	0.00	Hz
<b>A 162</b>	[VR] input active range end frequency	The output frequency corresponding to the current input range ending point, range is 0.0 to 400.0 Hz	✘	0.00	Hz
<b>A 163</b>	[VR] input active range start %	The starting point (offset) for the current input range, range is 0. to 100.%	✘	0.	%
<b>A 164</b>	[VR] input active range end %	The ending point (offset) for the current input range, range is 0. to 100.%	✘	100.	%
<b>A 165</b>	[VR] input start frequency select	Two options; select codes: 00...Use offset (A 161 value) 01...Use 0Hz	✘	01	—

## Fine Tuning Functions

Func. Code	"b" Function		Run Mode Edit	Defaults	
	Name	Description		Initial data	Units
b001	Restart mode on power failure / under-voltage trip	Select inverter restart method, Five option codes: 00...Alarm output after trip, no automatic restart 01...Restart at 0Hz 02...Resume operation after frequency matching 03...Resume previous freq. after freq. matching, then decelerate to stop and display trip info 04...Resume operation after active freq. matching	X	00	-
b002	Allowable under-voltage power failure time	The amount of time a power input under-voltage can occur without tripping the power failure alarm. Range is 0.3 to 25 sec. If under-voltage exists longer than this time, the inverter trips, even if the restart mode is selected.	X	1.0	sec.
b003	Retry wait time before motor restart	Time delay after under-voltage condition goes away, before the inverter runs motor again. Range is 0.3 to 100 seconds.	X	1.0	sec.
b004	Instantaneous power failure / under-voltage trip alarm enable	Three option codes: 00...Disable 01...Enable 02...Disable during stop and decelerates to a stop	X	00	-
b005	Number of restarts on power failure / under-voltage trip events	Two option codes: 00...Restart 16 times 01...Always restart	X	00	-
b007	Restart frequency threshold	Restart the motor from 0Hz if the frequency becomes less than this set value during the motor is coasting, range is 0 to 400Hz	X	0.00	Hz
b008	Restart mode on over voltage / over current trip	Select inverter restart method, Five option codes: 00...Alarm output after trip, no automatic restart 01...Restart at 0Hz 02...Resume operation after frequency matching 03...Resume previous freq. after active freq. matching, then decelerate to stop and display trip info 04...Resume operation after active freq. matching	X	00	-
b010	Number of retry on over voltage / over current trip	Range is 1 to 3 times	X	3	times
b011	Retry wait time on over voltage / over current trip	Range is 0.3 to 100 sec.	X	1.0	sec.

"b" Function			Run Mode Edit	Defaults	
Func. Code	Name	Description		Initial data	Units
b012	Level of electronic thermal	Set a level between 20% and 100% for the rated inverter current.	✗	Rated current for each inverter model *1	A
b212	Level of electronic thermal, 2 <sup>nd</sup> motor		✗		A
b013	Electronic thermal characteristic	Select from three curves, option codes:	✗	01	–
b213	Electronic thermal characteristic, 2 <sup>nd</sup> motor	00...Reduced torque 01...Constant torque 02...Free setting	✗	01	–
b015	Free setting electronic thermal ~freq.1	Range is 0 to 400Hz	✗	0.0	Hz
b016	Free setting electronic thermal ~current1	Range is 0 to inverter rated current Amps	✗	0.00	Amps
b017	Free setting electronic thermal ~freq.2	Range is 0 to 400Hz	✗	0.0	Hz
b018	Free setting electronic thermal ~current2	Range is 0 to inverter rated current Amps	✗	0.00	Amps
b019	Free setting electronic thermal ~freq.3	Range is 0 to 400Hz	✗	0.0	Hz
b020	Free setting electronic thermal ~current3	Range is 0 to inverter rated current Amps	✗	0.00	Amps
b021	Overload restriction operation mode	Select the operation mode during overload conditions, four options, option codes:	✗	01	–
b221	Overload restriction operation mode, 2 <sup>nd</sup> motor	00...Disabled 01...Enabled for acceleration and constant speed 02...Enabled for constant speed only 03...Enabled for acceleration and constant speed, increase speed at regen.	✗	01	–
b022	Overload restriction level	Sets the level of overload restriction, between 20% and 200% of the rated current of the inverter, setting resolution is 1% of rated current	✗	Rated current x 1.5	Amps
b222	Overload restriction level, 2 <sup>nd</sup> motor		✗	Rated current x 1.5	Amps
b023	Deceleration rate at overload restriction	Sets the deceleration rate when inverter detects overload, range is 0.1 to 3000.0, resolution 0.1	✗	1.0	sec.
b223	Deceleration rate at overload restriction, 2 <sup>nd</sup> motor		✗	1.0	sec.
b024	Overload restriction operation mode 2	Select the operation mode during overload conditions, four options, option codes: 00...Disabled 01...Enabled for acceleration and constant speed 02...Enabled for constant speed only 03...Enabled for acceleration and constant speed, increase speed at regen.	✗	01	–

"b" Function			Run Mode Edit	Defaults	
Func. Code	Name	Description		Initial data	Units
<b>b025</b>	Overload restriction level 2	Sets the level of overload restriction, between 20% and 200% of the rated current of the inverter, setting resolution is 1% of rated current	✗	Rated current x 1.5	–
<b>b026</b>	Deceleration rate 2 at overload restriction	Sets the deceleration rate when inverter detects overload, range is 0.1 to 3000.0, resolution 0.1	✗	1.0	sec.
<b>b027</b>	OC suppression selection	Two option codes: 00...Disabled 01...Enabled	✗	01	–
<b>b028</b>	Current level of active freq. matching	Sets the current level of active freq. matching restart, range is 0.2*inverter rated current to 2.0*inverter rated current, resolution 0.1	✗	Rated current	A
<b>b029</b>	Deceleration rate of active freq. matching	Sets the deceleration rate when active freq. matching restart, range is 0.1 to 3000.0, resolution 0.1	✗	0.5	sec.
<b>b030</b>	Start freq. of active freq. matching	Three option codes: 00...freq at previous shutoff 01...start from max. Hz 02...start from set frequency	✗	00	–
<b>b031</b>	Software lock mode selection	Prevents parameter changes, in five options, option codes: 00...all parameters except <b>b031</b> are locked when [SFT] terminal is ON 01...all parameters except <b>b031</b> and output frequency <b>F001</b> are locked when [SFT] terminal is ON 02...all parameters except <b>b031</b> are locked 03...all parameters except <b>b031</b> and output frequency <b>F001</b> are locked 10...High level access including <b>b031</b> <i>See appendix C for the accessible parameters in this mode.</i>	✗	01	–
<b>b033</b>	Motor cable length parameter	Set range is 5 to 20.	✗	10.	–
<b>b034</b>	Run/power ON warning time	Range is, 0.:Warning disabled 1. to 9999.: 10~99,990 hrs (unit: 10) 1000 to 6553: 100,000~655,350 hrs (unit: 100)	✗	0.	Hrs.
<b>b035</b>	Rotation direction restriction	Three option codes: 00...No restriction 01...Reverse rotation is restricted 02...Forward rotation is restricted	✗	00	–
<b>b036</b>	Reduced voltage start selection	Set range, 0 (disabling the function), 1 (approx. 6ms) to 255 (approx. 1.5s)	✗	2	–

"b" Function			Run Mode Edit	Defaults	
Func. Code	Name	Description		Initial data	Units
<b>b037</b>	Function code display restriction	Seven option codes: 00...Full display 01...Function-specific display 02...User setting (and <b>b037</b> ) 03...Data comparison display 04...Basic display 05...Monitor display only	✗	04	–
<b>b038</b>	Initial display selection	000...Func. code that SET key pressed last displayed.(*) 001~030...d001~d030 displayed 201...F001 displayed 202...B display of LCD operator	✗	001	–
<b>b039</b>	Automatic user parameter registration	Two option codes: 00...Disable 01...Enable	✗	00	–
<b>b040</b>	Torque limit selection	Four option codes: 00...Quadrant-specific setting mode 01...Terminal-switching mode 02...Analog voltage input mode(O)	✗	00	–
<b>b041</b>	Torque limit 1 (fwd/power)	Torque limit level in forward powering quadrant, range is 0 to 200%/no(disabled)	✗	200	%
<b>b042</b>	Torque limit 2 (rev/power)	Torque limit level in forward powering quadrant, range is 0 to 200%/no(disabled)	✗	200	%
<b>b043</b>	Torque limit 3 (rev/power)	Torque limit level in reverse powering quadrant, range is 0 to 200%/no(disabled)	✗	200	%
<b>b044</b>	Torque limit 4 (fwd/regen.)	Torque limit level in forward regen. quadrant, range is 0 to 200%/no(disabled)	✗	200	%
<b>b045</b>	Torque LAD STOP selection	Two option codes: 00...Disable 01...Enable	✗	00	
<b>b046</b>	Reverse run protection	Two option codes: 00...No protection 01...Reverse rotation is protected	✗	01	–
<b>b049</b>	Dual Rating Selection	It is not possible to change.	✗	00	
<b>b050</b>	Controlled deceleration on power loss	Four option codes: 00...Trips 01...Decelerates to a stop 02...Decelerates to a stop with DC bus voltage controlled 03...Decelerates to a stop with DC bus voltage controlled, then restart	✗	00	–
<b>b051</b>	DC bus voltage trigger level of ctrl. decel.	Setting of DC bus voltage to start controlled decel. operation. Range is 0.0 to 1000.0	✗	220.0	V
<b>b052</b>	Over-voltage threshold of ctrl. decel.	Setting the OV-LAD stop level of controlled decel. operation. Range is 0.0 to 1000.0	✗	360.0	V
<b>b053</b>	Deceleration time of ctrl. decel.	Range is 0.01 to 3600.0	✗	1.0	sec.

"b" Function			Run Mode Edit	Defaults	
Func. Code	Name	Description		Initial data	Units
<b>b054</b>	Initial freq. drop of ctrl. decel.	Setting of initial freq. drop. Range is 0.0 to 10.0 Hz	✗	0.0	Hz
<b>b060</b>	Maximum-limit level of window comparator (O)	Set range, {Min.-limit level ( <b>b061</b> ) + hysteresis width ( <b>b062</b> )x2} to 100 % (Minimum of 0%)	✗	100.	%
<b>b061</b>	Minimum-limit level of window comparator (O)	Set range, 0 to {Max.-limit level ( <b>b060</b> ) - hysteresis width ( <b>b062</b> )x2} % (Maximum of 0%)	✓	0.	%
<b>b062</b>	Hysteresis width of window comparator (O)	Set range, 0 to {Max.-limit level ( <b>b060</b> ) - Min.-limit level ( <b>b061</b> )} / 2 % (Maximum of 10%)	✓	0.	%
<b>b063</b>	Maximum-limit level of window comparator (OI)	Set range, {Min.-limit level ( <b>b064</b> ) + hysteresis width ( <b>b065</b> )x2} to 100 % (Minimum of 0%)	✓	100.	%
<b>b064</b>	Minimum-limit level of window comparator (OI)	Set range, 0 to {Max.-limit level ( <b>b063</b> ) - hysteresis width ( <b>b065</b> )x2} % (Maximum of 0%)	✓	0.	%
<b>b065</b>	Hysteresis width of window comparator (OI)	Set range, 0 to {Max.-limit level ( <b>b063</b> ) - Min.-limit level ( <b>b064</b> )} / 2 % (Maximum of 10%)	✓	0.	%
<b>b070</b>	Operation level at O disconnection	Set range, 0 to 100%, or "no" (ignore)	✗	no	–
<b>b071</b>	Operation level at OI disconnection	Set range, 0 to 100%, or "no" (ignore)	✗	no	–
<b>b075</b>	Ambient temperature setting	Set range is, -10~50 °C	✓	40	°C
<b>b078</b>	Watt-hour clearance	Two option codes: 00...OFF 01...ON (press STR then clear)	✓	00	–
<b>b079</b>	Watt-hour display gain	Set range is, 1.~1000.	✓	1.	
<b>b082</b>	Start frequency	Sets the starting frequency for the inverter output, range is 0.10 to 9.99 Hz	✗	0.50	Hz
<b>b083</b>	Carrier frequency	Sets the PWM carrier (internal switching frequency), range is 2.0 to 15.0 kHz	✗	2.0	kHz
<b>b084</b>	Initialization mode (parameters or trip history)	Select initialized data, five option codes: 00...Initialization disabled 01...Clears Trip history 02...Initializes all Parameters 03...Clears Trip history and initializes all parameters 04...Clears Trip history and initializes all parameters and EzSQ program	✗	00	–
<b>b085</b>	Country for initialization	Select default parameter values for country on initialization, two option codes: 00...area A      01...area B	✗	00	–
<b>b086</b>	Frequency scaling conversion factor	Specify a constant to scale the displayed frequency for <b>d007</b> monitor, range is 0.01 to 99.99	✗	1.00	–



"b" Function			Run Mode Edit	Defaults	
Func. Code	Name	Description		Initial data	Units
b087	STOP key enable	Select whether the STOP key on the keypad is enabled, three option codes: 00...Enabled 01...Disabled always 02... Disabled for stop	✗	00	–
b088	Restart mode after FRS	Selects how the inverter resumes operation when free-run stop (FRS) is cancelled, three options: 00...Restart from 0Hz 01...Restart from frequency detected from real speed of motor (freq. matching) 02...Restart from frequency detected from real speed of motor (active freq. matching)	✗	00	–
b089	Automatic carrier frequency reduction	Three option codes: 00...Disabled 01...Enabled, depending on the output current 02...Enabled, depending on the heat-sink temperature	✗	01	–
b090	Dynamic braking usage ratio	Selects the rate of use (in %) of the regenerative braking resistor per 100 sec. intervals, range is 0.0 to 100%. 0%: Function disabled >0%: Enabled, per value	✗	0.0	%
b091	Stop mode selection	Select how the inverter stops the motor, two option codes: 00...DEC (decelerate to stop) 01...FRS (free-run to stop)	✗	00	–
b092	Cooling fan control	Selects when the fan is ON during inverter operation, four options: 00...Fan is always ON 01...Fan is ON during run, OFF during stop (5 minute delay from ON to OFF) 02...Fan is temperature controlled	✗	01	–
b093	Clear elapsed time of cooling fan	Two option codes: 00...Count 01...Clear	✗	00	–
b094	Initialization target data	Select initialized parameters, four option codes: 00...All parameters 01...All parameters except in/output terminals and communication. 02...Only registered parameters in Uxxx. 03...All parameters except registered parameters in Uxxx and b037.	✗	00	–
b095	Dynamic braking control (BRD) selection	Three option codes: 00...Disable 01...Enable during run only 02...Enable always	✗	01	–

"b" Function			Run Mode Edit	Defaults	
Func. Code	Name	Description		Initial data	Units
<b>b096</b>	BRD activation level	Range is: 330 to 380V (200V class)	✗	360	V
<b>b097</b>	BRD resistor value	Min.Resistance to 600.0	✗	Min. Resistance	Ohm
<b>b 100</b>	Free V/F setting, freq.1	Set range, 0 ~ value of <b>b 102</b>	✗	0.	Hz
<b>b 101</b>	Free V/F setting, voltage.1	Set range, 0 ~ 800V	✗	0.0	V
<b>b 102</b>	Free V/F setting, freq.2	Set range, value of <b>b 100</b> ~ <b>b 104</b>	✗	0.	Hz
<b>b 103</b>	Free V/F setting, voltage.2	Set range, 0 ~ 800V	✗	0.0	V
<b>b 104</b>	Free V/F setting, freq.3	Set range, value of <b>b 102</b> ~ <b>b 106</b>	✗	0.	Hz
<b>b 105</b>	Free V/F setting, voltage.3	Set range, 0 ~ 800V	✗	0.0	V
<b>b 106</b>	Free V/F setting, freq.4	Set range, value of <b>b 104</b> ~ <b>b 108</b>	✗	0.	Hz
<b>b 107</b>	Free V/F setting, voltage.4	Set range, 0 ~ 800V	✗	0.0	V
<b>b 108</b>	Free V/F setting, freq.5	Set range, value of <b>b 108</b> ~ <b>b 110</b>	✗	0.	Hz
<b>b 109</b>	Free V/F setting, voltage.5	Set range, 0 ~ 800V	✗	0.0	V
<b>b 110</b>	Free V/F setting, freq.6	Set range, value of <b>b 108</b> ~ <b>b 112</b>	✗	0.	Hz
<b>b 111</b>	Free V/F setting, voltage.6	Set range, 0 ~ 800V	✗	0.0	V
<b>b 112</b>	Free V/F setting, freq.7	Set range, <b>b 110</b> ~ 400	✗	0.	Hz
<b>b 113</b>	Free V/F setting, voltage.7	Set range, 0 ~ 800V	✗	0.0	V
<b>b 120</b>	Brake control enable	Two option codes: 00...Disable 01...Enable	✗	00	-
<b>b 121</b>	Brake Wait Time for Release	Set range: 0.00 to 5.00 sec	✗	0.00	sec.
<b>b 122</b>	Brake Wait Time for Acceleration	Set range: 0.00 to 5.00 sec	✗	0.00	sec.
<b>b 123</b>	Brake Wait Time for Stopping	Set range: 0.00 to 5.00 sec	✗	0.00	sec.
<b>b 124</b>	Brake Wait Time for Confirmation	Set range: 0.00 to 5.00 sec	✗	0.00	sec.
<b>b 125</b>	Brake release freq.	Set range: 0 to 400Hz	✗	0.00	sec.
<b>b 126</b>	Brake release current	Set range: 0~200% of inverter rated current	✗	(rated current)	A
<b>b 127</b>	Braking freq. setting	Set range: 0 to 400Hz	✗	0.00	Hz
<b>b 130</b>	Deceleration overvoltage suppression enable	00...Disabled 01...Enabled 02...Enabled with accel.	✗	00	-
<b>b 131</b>	Decel. overvolt. suppress level	DC bus voltage of suppression. Range is: 200V class...330 to 395	✗	380	V
<b>b 132</b>	Decel. overvolt. Suppress const.	Accel. rate when b130=02. Set range: 0.10 ~ 30.00 sec.	✗	1.00	sec.
<b>b 133</b>	Decel. overvolt. Suppress proportional gain	Proportional gain when b130=01. Range is: 0.00 to 5.00	✓	0.20	-

"b" Function			Run Mode Edit	Defaults	
Func. Code	Name	Description		Initial data	Units
<b>b 134</b>	Decel. overvolt. Suppress integral time	Integration time when b130=01. Range is: 0.00 to 150.0	✓	1.0	sec.
<b>b 145</b>	GS input mode	Two option codes: 00...No trip (Hardware shutoff only) 01...Trip	✗	00	–
<b>b 150</b>	Display ex.operator connected	When an external operator is connected via RS-422 port, the built-in display is locked and shows only one "d" parameter configured in: d001 ~ d030	✗	001	–
<b>b 160</b>	1st parameter of Dual Monitor	Set any two "d" parameters in b160 and b161, then they can be monitored in d050. The two parameters are switched by up/down keys. Set range: d001 ~ d030	✗	001	–
<b>b 161</b>	2nd parameter of Dual Monitor		✗	002	–
<b>b 163</b>	Frequency set in monitoring	Two option codes: 00...Freq. set disabled 01...Freq. set enabled	✓	00	–
<b>b 164</b>	Automatic return to the initial display	10 min. after the last key operation, display returns to the initial parameter set by b030. Two option codes: 00...Disable 01...Enable	✓	00	–
<b>b 165</b>	Ex. operator com. loss action	Five option codes: 00...Trip 01...Trip after deceleration to a stop 02...Ignore 03...Coasting (FRS) 04...Decelerates to a stop	✓	02	–
<b>b 166</b>	Data Read/Write select	00... Read/Write OK 01... Protected	✗	00	–
<b>b 171</b>	Inverter mode selection	Three option codes: 00...No function 01...Std. IM (Induction Motor) 03...PM(Permanent Magnet Motor)	✗	00	–
<b>b 180</b>	Initialization trigger (*)	This is to perform initialization by parameter input with b084, b085 and b094. Two option codes: 00...Initialization disable 01...Perform initialization	✗	00	–
<b>b 190</b>	Password Settings A	0000(Invalid Password) 0001-FFFF(Password)	✗	0000	–
<b>b 191</b>	Password authentication A	0000-FFFF	✗	0000	–
<b>b 192</b>	Password Settings B	0000(Invalid Password) 0001-FFFF(Password)	✗	0000	–
<b>b 193</b>	Password authentication B	0000-FFFF	✗	0000	–

## Intelligent Terminal Functions

Func. Code	"C" Function		Run Mode Edit	Defaults	
	Name	Description		Initial data	Units
<b>C001</b>	Input [1] function	Select input terminal [1] function, 68 options (see next section)	✗	00 [FW]	–
<b>C002</b>	Input [2] function	Select input terminal [2] function, 68 options (see next section)	✗	01 [RV]	–
<b>C003</b>	Input [3] function [GS1 assignable]	Select input terminal [3] function, 68 options (see next section)	✗	02 [CF1]	–
<b>C004</b>	Input [4] function [GS2 assignable]	Select input terminal [4] function, 68 options (see next section)	✗	03 [CF2]	–
<b>C005</b>	Input [5] function [PTC assignable]	Select input terminal [5] function, 68 options (see next section)	✗	09 [2CH]	–
<b>C006</b>	Input [6] function	Select input terminal [6] function, 68 options (see next section)	✗	18 [RS]	–
<b>C007</b>	Input [7] function	Select input terminal [7] function, 68 options (see next section)	✗	13 [USP]	–
<b>C011</b>	Input [1] active state	Select logic conversion, two option codes: 00...normally open [NO] 01...normally closed [NC]	✗	00	–
<b>C012</b>	Input [2] active state		✗	00	–
<b>C013</b>	Input [3] active state		✗	00	–
<b>C014</b>	Input [4] active state		✗	00	–
<b>C015</b>	Input [5] active state		✗	00	–
<b>C016</b>	Input [6] active state		✗	00	–
<b>C017</b>	Input [7] active state		✗	00	–
<b>C021</b>	Output [11] function [EDM assignable]	48 programmable functions available for logic (discrete) outputs (see next section)	✗	01 [FA1]	–
<b>C022</b>	Output [12] function		✗	00 [RUN]	–
<b>C026</b>	Alarm relay function	48 programmable functions available for logic (discrete) outputs (see next section)	✗	05 [AL]	–
<b>C027</b>	[EO] terminal selection (Pulse/PWM output)	13 programmable functions: 00...Output frequency (PWM) 01...Output current (PWM) 02...Output torque (PWM) 03...Output frequency (Pulse train) 04...Output voltage (PWM) 05...Input power (PWM) 06...Electronic thermal load ratio (PWM) 07...LAD frequency (PWM) 08...Output current (Pulse train) 10...Heat sink temperature (PWM) 12...General output (PWM) 15...Pulse train input monitor 16...Option(PWM)	✗	07	–

"C" Function			Run Mode Edit	Defaults	
Func. Code	Name	Description		Initial data	Units
C028	[AM] terminal selection (Analog voltage output 0...10V)	11 programmable functions: 00...Output frequency 01...Output current 02...Output torque 04...Output voltage 05...Input power 06...Electronic thermal load ratio 07...LAD frequency 10...Heat sink temperature 11...Output torque (with code) 13...General output 16...Option	✗	07 [LAD]	-
C030	Digital current monitor reference value	Current with digital current monitor output at 1,440Hz Range is 20%~200% of rated current	✓	Rated current	A
C031	Output [11] active state	Select logic conversion, two option codes: 00...normally open [NO] 01...normally closed [NC]	✗	00	-
C032	Output [12] active state		✗	00	-
C036	Alarm relay active state		✗	01	-
C038	Output mode of low current detection	Two option codes: 00...During acceleration, deceleration and constant speed 01...During constant speed only	✗	01	-
C039	Low current detection level	Set the level of low load detection, range is 0.0 to 2.0*inverter rated current	✗	INV rated current	A
C040	Output mode of overload warning	Two option codes: 00...During accel., decel. And constant speed 01...During constant speed only	✗	01	-
C041	Overload warning level	Sets the overload warning signal level between 0% and 200% (from 0 to two time the rated current of the inverter)	✗	Rated current x 1.15	A
C241	Overload warning level, 2 <sup>nd</sup> motor	Sets the overload warning signal level between 0% and 200% (from 0 to two time the rated current of the inverter)	✗	Rated current x 1.15	A
C042	Frequency arrival setting for acceleration	Sets the frequency arrival setting threshold for the output frequency during acceleration, range is 0.0 to 400.0 Hz	✗	0.0	Hz
C043	Frequency arrival setting for deceleration	Sets the frequency arrival setting threshold for the output frequency during deceleration, range is 0.0 to 400.0 Hz	✗	0.0	Hz
C044	PID deviation level	Sets the allowable PID loop error magnitude (absolute value), SP-PV, range is 0.0 to 100%	✗	3.0	%
C045	Frequency arrival setting 2 for acceleration	Set range is 0.0 to 400.0 Hz	✗	0.00	Hz
C046	Frequency arrival setting 2 for deceleration	Set range is 0.0 to 400.0 Hz	✗	0.00	Hz

"C" Function			Run Mode Edit	Defaults	
Func. Code	Name	Description		Initial data	Units
C047	Pulse train input/output scale conversion	If EO terminal is configured as pulse train input (C027=15), scale conversion is set in C047. Pulse-out = Pulse-in × (C047) Set range is 0.01 to 99.99	✓	1.00	
C052	PID FBV output high limit	When the PV exceeds this value, the PID loop turns OFF the PID second stage output, range is 0.0 to 100%	✗	100.0	%
C053	PID FBV output low limit	When the PV goes below this value, the PID loop turns ON the PID second stage output, range is 0.0 to 100%	✗	0.0	%
C054	Over-torque/under-torque selection	Two option codes: 00...Over-torque 01...Under-torque	✗	00	–
C055	Over/under-torque level (Forward powering mode)	Set range is 0 to 200%	✗	100.	%
C056	Over/under-torque level (Reverse regen. mode)	Set range is 0 to 200%	✗	100.	%
C057	Over/under-torque level (Reverse powering mode)	Set range is 0 to 200%	✗	100.	%
C058	Over/under-torque level (Forward regen. mode)	Set range is 0 to 200%	✗	100.	%
C059	Signal output mode of Over/under-torque	Two option codes: 00...During accel., decel. And constant speed 01...During constant speed only	✗	01	–
C061	Electronic thermal warning level	Set range is 0 to 100% Setting 0 means disabled.	✗	90	%
C063	Zero speed detection level	Set range is 0.0 to 100.0Hz	✗	0.00	Hz
C064	Heat sink overheat warning	Set range is 0 to 110 °C	✗	100.	°C
C071	Communication speed	Eight option codes: 03...2,400 bps 04...4,800 bps 05...9,600 bps 06...19,200 bps 07...38,400 bps 08...57,600 bps 09...76,800 bps 10...115,200 bps	✗	05	baud
C072	Modbus address	Set the address of the inverter on the network. Range is 1 to 247	✗	1.	–
C074	Communication parity	Three option codes: 00...No parity 01...Even parity 02...Odd parity	✗	00	–
C075	Communication stop bit	Two option codes: 1...1 bit 2...2 bit	✗	1	bit

"C" Function			Run Mode Edit	Defaults	
Func. Code	Name	Description		Initial data	Units
C076	Communication error select	Selects inverter response to communications error. Five options: 00... Trip 01... Decelerate to a stop and trip 02... Disable 03... Free run stop (coasting) 04... Decelerates to a stop	X	02	-
C077	Communication error time-out	Sets the communications watchdog timer period. Range is 0.00 to 99.99 sec 0.0 = disabled	X	0.00	sec.
C078	Communication wait time	Time the inverter waits after receiving a message before it transmits. Range is 0. to 1000. ms	X	0.	msec.
C081	O input span calibration	Scale factor between the external frequency command on terminals L-O (voltage input) and the frequency output, range is 0.0 to 200%	✓	100.0	%
C082	O1 input span calibration	Scale factor between the external frequency command on terminals L-O1 (voltage input) and the frequency output, range is 0.0 to 200%	✓	100.0	%
C085	Thermistor input (PTC) span calibration	Scale factor of PTC input. Range is 0.0 to 200%	✓	100.0	%
C091	Debug mode enable	Displays debug parameters. Two option codes: 00... Disable 01... Enable <b>&lt;Do not set&gt;</b> (for factory use)	✓	00	-
C096	Communication selection	00... Modbus-RTU 01... EzCOM 02... EzCOM<administrator>	X	00	-
C098	EzCOM start adr. of master	01-08	X	01	-
C099	EzCOM end adr. of master	01-08	X	01	-
C100	EzCOM starting trigger	00... Input terminal 01... Always	X	00	-
C101	Up/Down memory mode selection	Controls speed setpoint for the inverter after power cycle. Two option codes: 00... Clear last frequency (return to default frequency F001) 01... Keep last frequency adjusted by UP/DWN	X	00	-

Func. Code	"C" Function		Run Mode Edit	Defaults	
	Name	Description		Initial data	Units
C 102	Reset selection	Determines response to Reset input [RS]. Four option codes: 00...Cancel trip state at input signal ON transition, stops inverter if in Run Mode 01...Cancel trip state at signal OFF transition, stops inverter if in Run Mode 02...Cancel trip state at input ON transition, no effect if in Run Mode 03...Clear the memories only related to trip status	X	00	-
C 103	Restart mode after reset	Determines the restart mode after reset is given, three option codes: 00...Start with 0 Hz 01...Start with freq. matching 02...Start with active freq. matching	X	00	-
C 104	UP/DWN clear mode	Freq. set value when UDC signal is given to the input terminal, two option codes: 00...0 Hz 01...Original setting (in the EEPROM memory at power on)	X	00	-
C 105	EO gain adjustment	Set range is 50 to 200%	✓	100.	%
C 106	AM gain adjustment	Set range is 50 to 200%	✓	100.	%
C 109	AM bias adjustment	Set range is 0 to 100%	✓	0.	%
C 111	Overload warning level 2	Sets the overload warning signal level between 0% and 200% (from 0 to two time the rated current of the inverter)	✓	Rated current x 1.15	A
C 130	Output [11] on delay	Set range is 0.0 to 100.0 sec.	X	0.0	sec.
C 131	Output [11] off delay		X	0.0	sec.
C 132	Output [12] on delay	Set range is 0.0 to 100.0 sec.	X	0.0	sec.
C 133	Output [12] off delay		X	0.0	sec.
C 140	Relay output on delay	Set range is 0.0 to 100.0 sec.	X	0.0	sec.
C 141	Relay output off delay		X	0.0	sec.
C 142	Logic output 1 operand A	All the programmable functions available for logic (discrete) outputs except LOG1 to LOG3, OPO, no	X	00	-
C 143	Logic output 1 operand B		X	00	-
C 144	Logic output 1 operator	Applies a logic function to calculate [LOG] output state, Three options: 00...[LOG] = A AND B 01...[LOG] = A OR B 02...[LOG] = A XOR B	X	00	-
C 145	Logic output 2 operand A	All the programmable functions available for logic (discrete) outputs except LOG1 to LOG3, OPO, no	X	00	-
C 146	Logic output 2 operand B		X	00	-



"C" Function			Run Mode Edit	Defaults	
Func. Code	Name	Description		Initial data	Units
C 147	Logic output 2 operator	Applies a logic function to calculate [LOG] output state, Three options: 00...[LOG] = A AND B 01...[LOG] = A OR B 02...[LOG] = A XOR B	X	00	–
C 148	Logic output 3 operand A	All the programmable functions available for logic (discrete) outputs except LOG1 to LOG3, OPO, no	X	00	–
C 149	Logic output 3 operand B		X	01	–
C 150	Logic output 3 operator	Applies a logic function to calculate [LOG] output state, Three options: 00...[LOG] = A AND B 01...[LOG] = A OR B 02...[LOG] = A XOR B	X	00	–
C 160	Input [1] response time	Sets response time of each input terminal, set range: 0 (x 2 [ms]) to 200 (x 2 [ms]) (0 to 400 [ms])	X	1.	–
C 161	Input [2] response time		X	1.	–
C 162	Input [3] response time		X	1.	–
C 163	Input [4] response time		X	1.	–
C 164	Input [5] response time		X	1.	–
C 165	Input [6] response time		X	1.	–
C 166	Input [7] response time		X	1.	–
C 169	Multistage speed/position determination time	Set range is 0. to 200. (x 10ms)	X	0.	msec.

**Input Function Summary Table** – This table shows all thirty-one intelligent input functions at a glance. Detailed description of these functions, related parameters and settings, and example wiring diagrams are in "Using Intelligent Input Terminals" on page 27.

Input Function Summary Table				
Option Code	Terminal Symbol	Function Name	Description	
00	FW	FORWARD Run/Stop	ON	Inverter is in Run Mode, motor runs forward
			OFF	Inverter is in Stop Mode, motor stops
01	RV	Reverse Run/Stop	ON	Inverter is in Run Mode, motor runs reverse
			OFF	Inverter is in Stop Mode, motor stops
02	CF1	Multi-speed Select, Bit 0 (LSB)	ON	Binary encoded speed select, Bit 0, logical 1
			OFF	Binary encoded speed select, Bit 0, logical 0
03	CF2	Multi-speed Select, Bit 1	ON	Binary encoded speed select, Bit 1, logical 1
			OFF	Binary encoded speed select, Bit 1, logical 0
04	CF3	Multi-speed Select, Bit 2	ON	Binary encoded speed select, Bit 2, logical 1
			OFF	Binary encoded speed select, Bit 2, logical 0
05	CF4	Multi-speed Select, Bit 3 (MSB)	ON	Binary encoded speed select, Bit 3, logical 1
			OFF	Binary encoded speed select, Bit 3, logical 0
06	JG	Jogging	ON	Inverter is in Run Mode, output to motor runs at jog parameter frequency
			OFF	Inverter is in Stop Mode
07	DB	External DC braking	ON	DC braking will be applied during deceleration
			OFF	DC braking will not be applied
08	SET	Set (select) 2nd Motor Data	ON	The inverter uses 2nd motor parameters for generating frequency output to motor
			OFF	The inverter uses 1st (main) motor parameters for generating frequency output to motor

Input Function Summary Table				
Option Code	Terminal Symbol	Function Name	Description	
09	2CH	2-stage Acceleration and Deceleration	ON	Frequency output uses 2nd-stage acceleration and deceleration values
			OFF	Frequency output uses standard acceleration and deceleration values
11	FRS	Free-run Stop	ON	Causes output to turn OFF, allowing motor to free run (coast) to stop
			OFF	Output operates normally, so controlled deceleration stop motor
12	EXT	External Trip	ON	When assigned input transitions OFF to ON, inverter latches trip event and displays <b>E 12</b>
			OFF	No trip event for ON to OFF, any recorded trip events remain in history until reset
13	USP	Unattended Start Protection	ON	On powerup, the inverter will not resume a Run command (mostly used in the US)
			OFF	On powerup, the inverter will resume a Run command that was active before power loss
14	CS	Commercial power source switchover	ON	Motor can be driven by commercial power
			OFF	Motor is driven via the inverter
15	SFT	Software Lock	ON	The keypad and remote programming devices are prevented from changing parameters
			OFF	The parameters may be edited and stored
16	AT	Analog Input Voltage/Current Select	ON	Refer to "Analog Input Settings" on page 41.
			OFF	
18	RS	Reset Inverter	ON	The trip condition is reset, the motor output is turned OFF, and powerup reset is asserted
			OFF	Normal power-ON operation
19	PTC	PTC thermistor Thermal Protection (C005 only)	ANLG	When a thermistor is connected to terminal [5] and [L], the inverter checks for over-temperature and will cause trip event and turn OFF output to motor
			OPEN	A disconnect of the thermistor causes a trip event, and the inverter turns OFF the motor
20	STA	Start (3-wire interface)	ON	Starts the motor rotation
			OFF	No change to present motor status
21	STP	Stop (3-wire interface)	ON	Stops the motor rotation
			OFF	No change to present motor status
22	F/R	FWD, REV (3-wire interface)	ON	Selects the direction of motor rotation: ON = FWD. While the motor is rotating, a change of F/R will start a deceleration, followed by a change in direction
			OFF	Selects the direction of motor rotation: OFF = REV. While the motor is rotating, a change of F/R will start a deceleration, followed by a change in direction
23	PID	PID Disable	ON	Temporarily disables PID loop control. Inverter output turns OFF as long as PID Enable is active ( <b>AD7 I=0 I</b> )
			OFF	Has no effect on PID loop operation, which operates normally if PID Enable is active ( <b>AD7 I=0 I</b> )
24	PIDC	PID Reset	ON	Resets the PID loop controller. The main consequence is that the integrator sum is forced to zero
			OFF	No effect on PID controller
27	UP	Remote Control UP Function (motorized speed pot.)	ON	Accelerates (increases output frequency) motor from current frequency
			OFF	Output to motor operates normally
28	DWN	Remote Control Down Function (motorized speed pot.)	ON	Decelerates (decreases output frequency) motor from current frequency
			OFF	Output to motor operates normally

**Input Function Summary Table**

Option Code	Terminal Symbol	Function Name	Description	
29	UDC	Remote Control Data Clearing	ON	Clears the UP/DWN frequency memory by forcing it to equal the set frequency parameter F001. Setting C 10 1 must be set=00 to enable this function to work
			OFF	UP/DWN frequency memory is not changed
31	OPE	Operator Control	ON	Forces the source of the output frequency setting R00 1 and the source of the Run command R002 to be from the digital operator
			OFF	Source of output frequency set by R00 1 and source of Run command set by R002 is used
32	SF1	Multi-speed Select, Bit operation Bit 1	ON	Bit encoded speed select, Bit 1, logical 1
			OFF	Bit encoded speed select, Bit 1, logical 0
33	SF2	Multi-speed Select, Bit operation Bit 2	ON	Bit encoded speed select, Bit 2, logical 1
			OFF	Bit encoded speed select, Bit 2, logical 0
34	SF3	Multi-speed Select, Bit operation Bit 3	ON	Bit encoded speed select, Bit 3, logical 1
			OFF	Bit encoded speed select, Bit 3, logical 0
35	SF4	Multi-speed Select, Bit operation Bit 4	ON	Bit encoded speed select, Bit 4, logical 1
			OFF	Bit encoded speed select, Bit 4, logical 0
36	SF5	Multi-speed Select, Bit operation Bit 5	ON	Bit encoded speed select, Bit 5, logical 1
			OFF	Bit encoded speed select, Bit 5, logical 0
37	SF6	Multi-speed Select, Bit operation Bit 6	ON	Bit encoded speed select, Bit 6, logical 1
			OFF	Bit encoded speed select, Bit 6, logical 0
38	SF7	Multi-speed Select, Bit operation Bit 7	ON	Bit encoded speed select, Bit 7, logical 1
			OFF	Bit encoded speed select, Bit 7, logical 0
39	OLR	Overload Restriction Source Changeover	ON	Perform overload restriction
			OFF	Normal operation
40	TL	Torque Limit Selection	ON	Setting of b040 is enabled
			OFF	Max. torque is limited with 200%
41	TRQ1	Torque limit switch 1	ON	Torque limit related parameters of Powering/regen, and FW/RV modes are selected by the combinations of these inputs.
			OFF	
42	TRQ2	Torque limit switch 2	ON	
			OFF	
44	BOK	Brake confirmation	ON	Brake wait time (b 124) is valid
			OFF	Brake wait time (b 124) is not valid
46	LAC	LAD cancellation	ON	Set ramp times are ignored. Inverter output immediately follows the freq. command.
			OFF	Accel. and/or decel. is according to the set ramp time
47	PCLR	Pulse counter clear	ON	Clear the position deviation data
			OFF	Maintain the position deviation data
50	ADD	ADD frequency enable	ON	Adds the R 145 (add frequency) value to the output frequency
			OFF	Does not add the R 145 value to the output frequency
51	F-TM	Force Terminal Mode	ON	Force inverter to use input terminals for output frequency and Run command sources
			OFF	Source of output frequency set by R00 1 and source of Run command set by R002 is used
52	ATR	Enable torque command input	ON	Torque control command input is enabled
			OFF	Torque control command input is disabled
53	KHC	Clear watt-hour data	ON	Clear watt-hour data
			OFF	No action
56	MI1	General purpose input (1)	ON	General purpose input (1) is made ON under EzSQ
			OFF	General purpose input (1) is made OFF under EzSQ
57	MI2	General purpose input (2)	ON	General purpose input (2) is made ON under EzSQ
			OFF	General purpose input (2) is made OFF under EzSQ

Input Function Summary Table				
Option Code	Terminal Symbol	Function Name	Description	
58	MI3	General purpose input (3)	ON	General purpose input (3) is made ON under EzSQ
			OFF	General purpose input (3) is made OFF under EzSQ
59	MI4	General purpose input (4)	ON	General purpose input (4) is made ON under EzSQ
			OFF	General purpose input (4) is made OFF under EzSQ
60	MI5	General purpose input (5)	ON	General purpose input (5) is made ON under EzSQ
			OFF	General purpose input (5) is made OFF under EzSQ
61	MI6	General purpose input (6)	ON	General purpose input (6) is made ON under EzSQ
			OFF	General purpose input (6) is made OFF under EzSQ
62	MI7	General purpose input (7)	ON	General purpose input (7) is made ON under EzSQ
			OFF	General purpose input (7) is made OFF under EzSQ
65	AHD	Analog command hold	ON	Analog command is held
			OFF	Analog command is not held
66	CP1	Multistage-position switch (1)	ON	Multistage position commands are set according to the combination of these switches.
			OFF	
67	CP2	Multistage-position switch (2)	ON	
			OFF	
68	CP3	Multistage-position switch (3)	ON	
			OFF	
69	ORL	Limit signal of homing	ON	Limit signal of homing is ON
			OFF	Limit signal of homing is OFF
70	ORG	Trigger signal of homing	ON	Starts homing operation
			OFF	No action
73	SPD	Speed/position changeover	ON	Speed control mode
			OFF	Position control mode
77	GS1	GS1 input	ON	EN60204-1 related signals: Signal input of "Safe torque off" function.
			OFF	
78	GS2	GS2 input	ON	
			OFF	
81	485	Start EzCOM	ON	Starts EzCOM
			OFF	No execution
82	PRG	Executing EzSQ program	ON	Executing EzSQ program
			OFF	No execution
83	HLD	Retain output frequency	ON	Retain the current output frequency
			OFF	No retention
84	ROK	Permission of Run command	ON	Run command permitted
			OFF	Run command is not permitted
85	EB	Rotation direction detection (C007 only)	ON	Forward rotation
			OFF	Reverse rotation
86	DISP	Display limitation	ON	Only a parameter configured in <b>6038</b> is shown
			OFF	All the monitors can be shown
255	no	No function	ON	(input ignored)
			OFF	(input ignored)

**Output Function Summary Table** – This table shows all functions for the logical outputs (terminals [11], [12] and [AL]) at a glance. Detailed descriptions of these functions, related parameters and settings, and example wiring diagrams are in “Using Intelligent Output Terminals” on page 36.

Output Function Summary Table				
Option Code	Terminal Symbol	Function Name	Description	
00	RUN	Run Signal	ON	When the inverter is in Run Mode
			OFF	When the inverter is in Stop Mode
01	FA1	Frequency Arrival Type 1–Constant Speed	ON	When output to motor is at the set frequency
			OFF	When output to motor is OFF, or in any acceleration or deceleration ramp
02	FA2	Frequency Arrival Type 2–Over frequency	ON	When output to motor is at or above the set freq, even if in accel (C042) or decel (C043) ramps
			OFF	When output to motor is OFF, or at a level below the set frequency
03	OL	Overload Advance Notice Signal 1	ON	When output current is more than the set threshold (C041) for the overload signal
			OFF	When output current is less than the set threshold for the deviation signal
04	OD	Output Deviation for PID Control	ON	When PID error is more than the set threshold for the deviation signal
			OFF	When PID error is less than the set threshold for the deviation signal
05	AL	Alarm Signal	ON	When an alarm signal has occurred and has not been cleared
			OFF	When no alarm has occurred since the last cleaning of alarm(s)
06	FA3	Frequency Arrival Type 3–Set frequency	ON	When output to motor is at the set frequency, during accel (C042) and decel (C043).
			OFF	When output to motor is OFF, or is not at a level of the set frequency
07	OTQ	Over/under Torque Signal	ON	Estimated motor torque exceeds the specified level
			OFF	Estimated motor torque is lower than the specified level
09	UV	Undervoltage	ON	Inverter is in Undervoltage
			OFF	Inverter is not in Undervoltage
10	TRQ	Torque Limited Signal	ON	Torque limit function is executing
			OFF	Torque limit function is not executing
11	RNT	Run Time Expired	ON	Total running time of the inverter exceeds the specified value
			OFF	Total running time of the inverter does not exceed the specified value
12	ONT	Power ON time Expired	ON	Total power ON time of the inverter exceeds the specified value
			OFF	Total power ON time of the inverter does not exceed the specified value
13	THM	Thermal Warning	ON	Accumulated thermal count exceeds the C061 set value
			OFF	Accumulated thermal count does not exceed the C061 set value
19	BRK	Brake Release Signal	ON	Output for brake release
			OFF	No action for brake
20	BER	Brake Error Signal	ON	Brake error has occurred
			OFF	Brake performance is normal

**Output Function Summary Table**

Option Code	Terminal Symbol	Function Name	Description	
21	ZS	Zero Hz Speed Detection Signal	ON	Output frequency falls below the threshold specified in <b>C063</b>
			OFF	Output frequency is higher than the threshold specified in <b>C063</b>
22	DSE	Speed Deviation Excessive	ON	Deviation of speed command and actual speed exceeds the specified value <b>P027</b> .
			OFF	Deviation of speed command and actual speed does not exceed the specified value <b>P027</b> .
23	POK	Positioning Completion	ON	Positioning is completed
			OFF	Positioning is not completed
24	FA4	Frequency Arrival Type 4—Over frequency	ON	When output to motor is at or above the set freq., even if in accel ( <b>C045</b> ) or decel ( <b>C046</b> ) ramps
			OFF	When output to motor is OFF, or at a level below the set frequency
25	FA5	Frequency Arrival Type 5—Set frequency	ON	When output to motor is at the set frequency, during accel ( <b>C045</b> ) and decel ( <b>C046</b> ).
			OFF	When output to motor is OFF, or is not at a level of the set frequency
26	OL2	Overload Advance Notice Signal 2	ON	When output current is more than the set threshold ( <b>C111</b> ) for the overload signal
			OFF	When output current is less than the set threshold for the deviation signal
27	ODc	Analog Voltage Input Disconnect Detection	ON	When the [O] input value < <b>b070</b> setting (signal loss detected)
			OFF	When no signal loss is detected
28	OIDc	Analog Current input Disconnect Detection	ON	When the [OI] input value < <b>b071</b> setting (signal loss detected)
			OFF	When no signal loss is detected
31	FBV	PID Second Stage Output	ON	Transitions to ON when the inverter is in RUN Mode and the PID Process Variable (PV) is less than the Feedback Low Limit ( <b>C053</b> )
			OFF	Transitions to OFF when the PID Process Variable (PV) exceeds the PID High Limit ( <b>C052</b> ), and transitions to OFF when the inverter goes from Run Mode to Stop Mode
32	NDc	Network Disconnect Detection	ON	When the communications watchdog timer (period specified by <b>C077</b> ) has time out
			OFF	When the communications watchdog timer is satisfied by regular communications activity
33	LOG1	Logic Output Function 1	ON	When the Boolean operation specified by <b>C143</b> has a logical "1" result
			OFF	When the Boolean operation specified by <b>C143</b> has a logical "0" result
34	LOG2	Logic Output Function 2	ON	When the Boolean operation specified by <b>C146</b> has a logical "1" result
			OFF	When the Boolean operation specified by <b>C146</b> has a logical "0" result
35	LOG3	Logic Output Function 3	ON	When the Boolean operation specified by <b>C149</b> has a logical "1" result
			OFF	When the Boolean operation specified by <b>C149</b> has a logical "0" result
39	WAC	Capacitor Life Warning Signal	ON	Lifetime of internal capacitor has expired.
			OFF	Lifetime of internal capacitor has not expired.

**Output Function Summary Table**

Option Code	Terminal Symbol	Function Name	Description	
40	WAF	Cooling Fan Warning Signal	ON	Lifetime of cooling fan has expired.
			OFF	Lifetime of cooling fan has not expired.
41	FR	Starting Contact Signal	ON	Either FW or RV command is given to the inverter
			OFF	No FW or RV command is given to the inverter, or both are given to the inverter
42	OHF	Heat Sink Overheat Warning	ON	Temperature of the heat sink exceeds a specified value (C064)
			OFF	Temperature of the heat sink does not exceed a specified value (C064)
43	LOC	Low load detection	ON	Motor current is less than the specified value (C039)
			OFF	Motor current is not less than the specified value (C039)
44	MO1	General Output 1	ON	General output 1 is ON
			OFF	General output 1 is OFF
45	MO2	General Output 2	ON	General output 2 is ON
			OFF	General output 2 is OFF
46	MO3	General Output 3	ON	General output 3 is ON
			OFF	General output 3 is OFF
50	IRDY	Inverter Ready Signal	ON	Inverter can receive a run command
			OFF	Inverter cannot receive a run command
51	FWR	Forward Rotation	ON	Inverter is driving the motor in forward direction
			OFF	Inverter is not driving the motor in forward direction
52	RVR	Reverse Rotation	ON	Inverter is driving the motor in reverse direction
			OFF	Inverter is not driving the motor in reverse direction
53	MJA	Major Failure Signal	ON	Inverter is tripping with major failure
			OFF	Inverter is normal, or is not tripping with major failure
54	WCO	Window Comparator for Analog Voltage Input	ON	Analog voltage input value is inside of the window comparator
			OFF	Analog voltage input value is outside of the window comparator
55	WCOI	Window Comparator for Analog Current Input	ON	Analog current input value is inside of the window comparator
			OFF	Analog current input value is outside of the window comparator
58	FREF	Frequency Command Source	ON	Frequency command is given from the operator
			OFF	Frequency command is not given from the operator
59	REF	Run Command Source	ON	Run command is given from the operator
			OFF	Run command is not given from the operator
60	SETM	2 <sup>nd</sup> Motor Selection	ON	2 <sup>nd</sup> motor is being selected
			OFF	2 <sup>nd</sup> motor is not being selected
62	EDM	STO (Safe Torque Off) Performance Monitor (Output terminal 11 only)	ON	STO is being performed
			OFF	STO is not being performed
63	OPO	Option card output	ON	(output terminal for option card)
			OFF	(output terminal for option card)
255	no	Not used	ON	-
			OFF	-



## Motor Constants Functions

"H" Function			Run Mode Edit	Defaults	
Func. Code	Name	Description		Initial data	Units
H001	Auto-tuning selection	Three option codes: 00...Disabled 01...Enabled with motor stop 02...Enabled with motor rotation	✗	00	–
H002	Motor constant selection	Four option codes: 00...Hitachi standard motor 02...Auto tuned data	✗	00	–
H202	Motor constant selection, 2 <sup>nd</sup> motor		✗	00	–
H003	Motor capacity	Eleven selections: 0.1/0.2/0.4/0.75/1.5/2.2/3.7/ 5.5/7.5/11/15/18.5	✗	Specified by the capacity of each inverter model	kW
H203	Motor capacity, 2 <sup>nd</sup> motor		✗		kW
H004	Motor poles setting	Four selections: 2 / 4 / 6 / 8 / 10	✗	4	poles
H204	Motor poles setting, 2 <sup>nd</sup> motor		✗	4	poles
H005	Motor speed response constant	Set range is 1 to 1000	✓	100.	–
H205	Motor speed response constant, 2 <sup>nd</sup> motor		✓	100.	–
H006	Motor stabilization constant	Motor constant (factory set), range is 0 to 255	✓	100.	–
H206	Motor stabilization constant, 2 <sup>nd</sup> motor		✓	100.	–
H020	Motor constant R1 (Hitachi motor)	0.001~65.535 ohms	✗	Specified by the capacity of each inverter mode	ohm
H220	Motor constant R1, 2 <sup>nd</sup> motor (Hitachi motor)		✗		ohm
H021	Motor constant R2 (Hitachi motor)	0.001~65.535 ohms	✗		ohm
H221	Motor constant R2, 2 <sup>nd</sup> motor (Hitachi motor)		✗		ohm
H022	Motor constant L (Hitachi motor)	0.01~655.35mH	✗		mH
H222	Motor constant L, 2 <sup>nd</sup> motor (Hitachi motor)		✗		mH
H023	Motor constant I0 (Hitachi motor)	0.01~655.35A	✗		A
H223	Motor constant I0, 2 <sup>nd</sup> motor (Hitachi motor)		✗		A
H024	Motor constant J (Hitachi motor)	0.001~9999 kgm <sup>2</sup>	✗		kgm <sup>2</sup>
H224	Motor constant J, 2 <sup>nd</sup> motor (Hitachi motor)		✗		kgm <sup>2</sup>
H030	Motor constant R1 (Auto tuned data)	0.001~65.535 ohms	✗	Specified by the capacity of each inverter mode	ohm
H230	Motor constant R1, 2 <sup>nd</sup> motor (Auto tuned data)		✗		ohm
H031	Motor constant R2 (Auto tuned data)		✗		ohm



"H" Function			Run Mode Edit	Defaults	
Func. Code	Name	Description		Initial data	Units
H231	Motor constant R2, 2 <sup>nd</sup> motor (Auto tuned data)		X		ohm
H032	Motor constant L (Auto tuned data)	0.01~655.35mH	X		mH
H232	Motor constant L, 2 <sup>nd</sup> motor (Auto tuned data)		X		mH
H033	Motor constant I0 (Auto tuned data)	0.01~655.35A	X		A
H233	Motor constant I0, 2 <sup>nd</sup> motor (Auto tuned data)		X		A
H034	Motor constant J (Auto tuned data)	0.001~9999 kgm <sup>2</sup>	X		kgm <sup>2</sup>
H234	Motor constant J, 2 <sup>nd</sup> motor (Auto tuned data)		X		kgm <sup>2</sup>
H050	Slip compensation P gain for V/f control with FB	0.00-10.00	X	0.2	Times
H051	Slip compensation I gain for V/f control with FB	0.-1000.	X	2.	s

## PM Motor Constants Functions

"H" Function			Run Mode Edit	Defaults	
Func. Code	Name	Description		Initial data	Units
H102	PM motor code setting	00...Hitachi standard (Use H106-H110 at motor constants) 01...Auto-Tuning (Use H109-H110, H111-H113 at motor constants)	X	00	-
H103	PM motor capacity	0.1/0.2/0.4/0.55/0.75/1.1/1.5/2.2/3.0/3.7/4.0/5.5/7.5/11.0/15.0/18.5	X	kW dependent	kW
H104	PM motor pole setting	2/4/6/8/10/12/14/16/18/20/22/24/26/28/30/32/34/36/38/40/42/44/46/48	X	kW dependent	Poles
H105	PM Rated Current	(0.00-1.00) × Rated current of the inverter [A]	X	kW dependent	A
H106	PM const R(Resistance)	0.001-65.535 [Ω]	X	kW dependent	ohm
H107	PM const Ld (d-axis inductance)	0.01-655.35 [mH]	X	kW dependent	mH
H108	PM const Lq (q-axis inductance)	0.01-655.35 [mH]	X	kW dependent	mH
H109	PM const Ke (Induction voltage constant)	0.0001-6.5535 [V/(rad/s)]	X	kW dependent	V/(rad/s)
H110	PM const J(Moment of inertia)	0.001-9999.000 [kgm <sup>2</sup> ]	X	kW dependent	kgm <sup>2</sup>
H111	PM const R (Resistance, Auto)	0.001-65.535 [Ω]	X	kW dependent	ohm

Func. Code	"H" Function		Run Mode Edit	Defaults	
	Name	Description		Initial data	Units
H 112	PM const Ld (d-axis inductance, Auto)	0.01-655.35 [mH]	✗	kW dependent	mH
H 113	PM const Lq (q-axis inductance, Auto)	0.01-655.35 [mH]	✗	kW dependent	mH
H 116	PM Speed Response	1-1000 [%]	✗	100	%
H 117	PM Starting Current	20.00-100.00 [%]	✗	70.00[%]	%
H 118	PM Starting Time	0.01-60.00 [s]	✗	1.00[s]	s
H 119	PM Stabilization Constant	0-120 [%]	✗	100[%]	%
H 121	PM Minimum Frequency	0.0-25.5 [%]	✓	8.0 [%]	%
H 122	PM No-Load Current	0.00-100.00 [%]	✓	10.00 [%]	%
H 123	PM Starting Method Select	00... Normal 01... Initial Magnet Position Estimation	✗	0	–
H 131	PM Initial Magnet Position Estimation 0V Wait Times	0-255	✗	10	–
H 132	PM Initial Magnet Position Estimation Detect Wait Times	0-255	✗	10	–
H 133	PM Initial Magnet Position Estimation Detect Times	0-255	✗	30	–
H 134	PM Initial Magnet Position Estimation Voltage Gain	0-200	✗	100	–

## Expansion Card Functions

“P” parameters will be appeared when the expansion option is connected.

Func. Code	“P” Function		Run Mode Edit	Defaults	
	Name	Description		Initial data	Units
P001	Reaction when option card error occurs	Two option codes: 00...Inverter trips 01...Ignores the error (Inverter continues operation)	✗	00	-
P003	[EA] terminal selection	Three option codes: 00...Speed reference (incl. PID) 01...For control with encoder feedback 02...Extended terminal for EzSQ	✗	00	-
P004	Pulse train input mode selection for feedback	Four option codes: 00...Single-phase pulse [EA] 01...2-phase pulse (90° difference) 1 ([EA] and [EB]) 02...2-phase pulse (90° difference) 2 ([EA] and [EB]) 03...Single-phase pulse [EA] and direction signal [EB]	✗	00	-
P011	Encoder pulse setting	Sets the pulse number (ppr) of the encoder, set range is 32~1024 pulses	✗	512.	-
P012	Simple positioning selection	Two option codes: 00...simple positioning deactivated 01...simple positioning activated	✗	00	-
P015	Creep Speed	Set range is start frequency (b002) ~10.00 Hz	✗	5.00	Hz
P026	Over-speed error detection level	Set range is 0~150%	✗	115.0	%
P027	Speed deviation error detection level	Set range is 0~120 Hz	✗	10.00	Hz
P031	Deceleration time Input Type	00...Operator 03...EzSQ	✗	00	-
P033	Torque command input selection	Six option codes: 00...Analog voltage input [O] 01...Analog current input [OI] 03...Operator, 05...Option	✗	00	-
P034	Torque command level input	Set range is 0~200%	✓	0.	%
P036	Torque bias mode selection	Five option codes: 00...No bias    01...Operator	✗	00	-
P037	Torque bias value setting	Range is -200~200%	✓	0.	%
P038	Torque bias polar selection	Two option codes: 00...According to the sign 01...According to the rotation direction 05...Option	✗	00	-
P039	Speed limit of Torque control (Forward rotation)	Set range is 0.00~120.00Hz	✓	0.00	Hz
P040	Speed limit of Torque control (Forward rotation)	Set range is 0.00~120.00Hz	✓	0.00	Hz

"P" Function			Run Mode Edit	Defaults	
Func. Code	Name	Description		Initial data	Units
P041	Speed / Torque control switching time	Set range is 0 to 1000 ms	✗	0.	ms
P044	Communication watchdog timer (for option)	Set range is 0.00 to 99.99s	✗	1.00	s
P045	Inverter action on communication error (for option)	00 (tripping), 01 (tripping after decelerating and stopping the motor), 02 (ignoring errors), 03 (stopping the motor after free-running), 04 (decelerating and stopping the motor)	✗	00	-
P046	DeviceNet polled I/O: Output instance number	0-20	✗	1	-
P048	Inverter action on communication idle mode	00 (tripping), 01 (tripping after decelerating and stopping the motor), 02 (ignoring errors), 03 (stopping the motor after free-running), 04 (decelerating and stopping the motor)	✗	00	-
P049	Motor poles setting for RPM	0/2/4/6/8/10/12/14/16/18/20/22/24/26/28/ 30/32/34/36/38/40/42/44/46/48	✗	0	-
P055	Pulse train input frequency scale setting	Sets the pulse numbers at max. frequency, set range is 1.0~32.0 kHz	✗	25.0	kHz
P056	Pulse train input frequency filter time constant setting	Set range is 0.01~2.00 sec.	✗	0.10	sec.
P057	Pulse train input bias setting	Set range is -100~100 %	✗	0.	%
P058	Limitation of the pulse train input setting	Set range is 0~100 %	✗	100.	%
P060	Multistage position 0	P073 to P072 (Displayed higher 4-digits only)	✓	0	-
P061	Multistage position 1		✓	0	-
P062	Multistage position 2		✓	0	-
P063	Multistage position 3		✓	0	-
P064	Multistage position 4		✓	0	-
P065	Multistage position 5		✓	0	-
P066	Multistage position 6		✓	0	-
P067	Multistage position 7		✓	0	-
P068	Homing mode selection	00...Low speed mode 01...High speed mode	✓	00	-
P069	Homing direction	00...Forward rotation side 01...Reverse rotation side	✓	01	-
P070	Low speed homing freq.	0 to 10Hz	✓	5.00	Hz
P071	High speed homing freq.	0 to 400Hz	✓	5.00	Hz
P072	Position range (Forward)	0 to +268435455(Higher 4-digits displayed)	✓	+268435455	-
P073	Position range (Reverse)	-268435455 to 0(Higher 4-digits displayed)	✓	-268435455	-

"P" Function			Run Mode Edit	Defaults	
Func. Code	Name	Description		Initial data	Units
<b>P075</b>	Positioning mode selection	<b>00</b> ...With limitation <b>01</b> ...No limitation (shorter route) P004 is to be set 00 or 01	<b>X</b>	00	-
<b>P077</b>	Encoder disconnection timeout	0.0 to 10.0 s	✓	1.0	sec.
<b>P100</b> ~ <b>P131</b>	EzSQ user parameter U(00) ~ U(31)	Each set range is 0~65535	✓	0.	-
<b>P140</b>	EzCOM number of data	1 to 5	✓	5	-
<b>P141</b>	EzCOM destination 1 address	1 to 247	✓	1	-
<b>P142</b>	EzCOM destination 1 register	0000 to FFFF	✓	0000	-
<b>P143</b>	EzCOM source 1 register	0000 to FFFF	✓	0000	-
<b>P144</b>	EzCOM destination 2 address	1 to 247	✓	2	-
<b>P145</b>	EzCOM destination 2 register	0000 to FFFF	✓	0000	-
<b>P146</b>	EzCOM source 2 register	0000 to FFFF	✓	0000	-
<b>P147</b>	EzCOM destination 3 address	1 to 247	✓	3	-
<b>P148</b>	EzCOM destination 3 register	0000 to FFFF	✓	0000	-
<b>P149</b>	EzCOM source 3 register	0000 to FFFF	✓	0000	-
<b>P150</b>	EzCOM destination 4 address	1 to 247	✓	4	-
<b>P151</b>	EzCOM destination 4 register	0000 to FFFF	✓	0000	-
<b>P152</b>	EzCOM source 4 register	0000 to FFFF	✓	0000	-
<b>P153</b>	EzCOM destination 5 address	1 to 247	✓	5	-
<b>P154</b>	EzCOM destination 5 register	0000 to FFFF	✓	0000	-
<b>P155</b>	EzCOM source 5 register	0000 to FFFF	✓	0000	-