

FRENIC-Eco
Profibus[®] Interface Card "OPC-F1-PDP"

 **CAUTION**

Thank you for purchasing our PROFIBUS DP Interface Card OPC-F1-PDP.

- This product is designed to connect the FRENIC-Eco series of inverters to PROFIBUS DP Communications Network. Read through this instruction manual and be familiar with the handling procedure for correct use.
- Improper handling blocks correct operation or causes a short life or failure.
- Deliver this manual to the end user of the product. The end user should keep this manual in a safe place until the PROFIBUS DP Interface Card is discarded.
- For the usage of inverters, refer to the instruction manual prepared for the FRENIC-Eco series of inverters.

Copyright © 2006 Fuji Electric FA Components & Systems Co., Ltd.

All rights reserved.

No part of this publication may be reproduced or copied without prior written permission from Fuji Electric FA Components & Systems Co., Ltd.

All products and company names mentioned in this manual are trademarks or registered trademarks of their respective holders.

The information contained herein is subject to change without prior notice for improvement.

Preface

Thank you for purchasing our PROFIBUS DP Interface Card OPC-F1-PDP.

Installing this card on your FRENIC-Eco allows you to connect the FRENIC-Eco to a PROFIBUS DP master node (e.g., PC and PLC) and control it as a slave unit using run and frequency commands, and access to function codes.

This product is certificated by a test laboratory officially approved by the PROFIBUS Organization and fully compliant with the PROFIBUS DP-V0 protocol.

How this manual is organized

This manual is made up of chapters 1 through 13.

Chapter 1 FEATURES

Gives an overview of the main features of the PROFIBUS DP interface card.

Chapter 2 ACCEPTANCE INSPECTION

Lists points to be checked upon delivery of the card and precautions for transportation and storage of the card. Also this chapter presents the appearance of the card and provides information on how to obtain a GSD file.

Chapter 3 FUNCTIONS AND CONFIGURATION OF THE CARD

Provides instructions on how to use the node address switches, terminating resistor switch and status indicator LEDs.

Chapter 4 INSTALLATION

Provides instructions and precautions for installing the card.

Chapter 5 WIRING

Provides wiring instructions around the terminal blocks on the card and the cable specifications.

Chapter 6 FUNCTION CODE SETTINGS REQUIRED FOR PROFIBUS COMMUNICATION

Describes the inverter's function codes to be set for receiving run and frequency commands via a PROFIBUS DP master node. It also lists the related function codes.

Chapter 7 ESTABLISHING A PROFIBUS COMMUNICATIONS LINK

Guides you to establish a PROFIBUS DP communications link between the PROFIBUS DP master node and this card (slave node).

Chapter 8 QUICK SETUP GUIDE FOR RUNNING THE INVERTER

Describes a simple profile (data format) dedicated to inverter's run and frequency commands, taking the actual data transaction data as an example.

Chapter 9 DETAILS OF PROFIBUS DP PROFILES

Details PROFIBUS DP profile data formats and parameters supported by this card. Furthermore, this chapter describes how the master node accesses inverter's function codes.

Chapter 10 INVERTER REACTION TO PROFIBUS COMMUNICATIONS ERRORS

Describes on how the inverter operates if a PROFIBUS communications error occurs.

Chapter 11 ALARM CODE LIST

Lists and explains inverter's alarm codes.

Chapter 12 TROUBLESHOOTING

Provides troubleshooting instructions for certain problems, e.g., when the inverter does not operate as ordered or when an alarm condition has been recognized.

Chapter 13 SPECIFICATIONS

Lists the general specifications and communications specifications.

Icons

The following icons are used throughout this manual.

 **Note** This icon indicates information which, if not heeded, can result in the product not operating to full efficiency, as well as information concerning incorrect operations and settings which can result in accidents.

 **Tip** This icon indicates information that can prove handy when performing certain settings or operations.

 This icon indicates a reference to more detailed information.

Table of Contents

Preface	1	Chapter 8 QUICK SETUP GUIDE FOR RUNNING THE INVERTER	11
How this manual is organized	1	8.1 Before Proceeding to Data Exchange	11
Chapter 1 FEATURES	3	8.2 Data Transaction Examples in Running an Inverter	11
Chapter 2 ACCEPTANCE INSPECTION	3	Chapter 9 DETAILS OF PROFIBUS PROFILES	14
Chapter 3 FUNCTIONS AND CONFIGURATION OF THE CARD	4	9.1 Description of PPO Types Supported.	14
3.1 Status Indicator LEDs	4	9.2 PCD Word Area	16
3.2 Node Address Switches	5	9.3 PCV Word Area	21
3.3 Terminating Resistor Switch	5	Chapter 10 INVERTER REACTION TO PROFIBUS COMMUNICATIONS ERRORS	28
3.4 Terminal Board	5	Chapter 11 ALARM CODE LIST	29
3.5 Setting the Transmission Speed (Baud rate)	5	Chapter 12 TROUBLESHOOTING	30
Chapter 4 INSTALLATION	6	Chapter 13 SPECIFICATIONS	31
Chapter 5 WIRING	7	13.1 General Specifications	31
Chapter 6 FUNCTION CODE SETTINGS REQUIRED FOR PROFIBUS COMMUNICATION	9	13.2 Communications Specifications	31
Chapter 7 ESTABLISHING A PROFIBUS COMMUNICATIONS LINK	10		

Chapter 1 FEATURES

The PROFIBUS DP interface card has the following features:

- PROFIBUS version: DP-V0
- Transmission speed: 9.6 Kbps to 12 Mbps
- Maximum network cable length per segment: 100 m (12 Mbps) to 1200 m (9.6 Kbps)
- Profile: PROFIdrive V2
- Able to read and write all function codes supported in FRENIC-Eco

Chapter 2 ACCEPTANCE INSPECTION

Unpack the package and check that:

- (1) A PROFIBUS DP interface card is contained in the package.
- (2) The card has not been damaged during transportation--no defective electronic devices, dents, or warp.
- (3) The model name "OPC-F1-PDP" is printed on the card. (See Figure 1.)

If you suspect the product is not working properly or if you have any questions about your product, contact your Fuji Electric representative.

This card is applicable to all FRENIC-Eco series of inverters and all software versions.

IMPORTANT

A GSD file, which is required for registering the PROFIBUS DP interface card to the PROFIBUS master node, does not come with the card. It is available as a free download from our website at:

<http://web1.fujielectric.co.jp/Kiki-Info-EN/User/index.html>

(Fuji Electric FA Components & Systems Co., Ltd. Technical Information site)

Before downloading, you are requested to register as a member (free of charge).

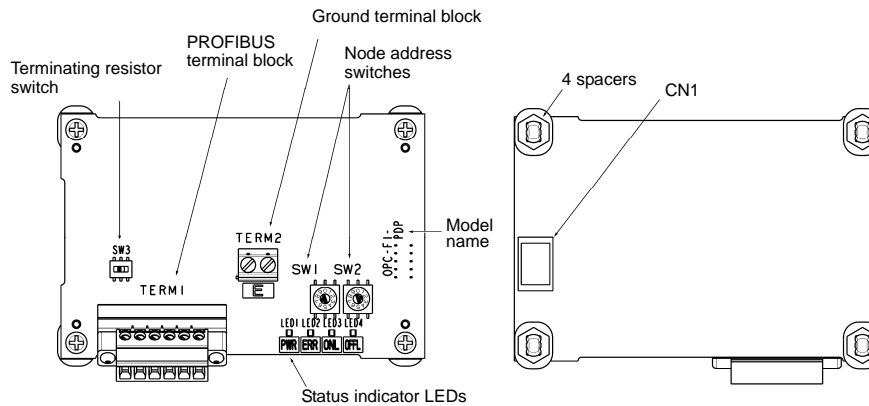

Figure 1 Front of the Card

Figure 2 Back of the Card

Chapter 3 FUNCTIONS AND CONFIGURATION OF THE CARD

3.1 Status Indicator LEDs

This interface card has four status indicator LEDs shown in Figure 3. They indicate the operation status of the card as listed in Table 1.



Figure 3 Status Indicator LEDs

Table 1 LED Indications and Operation Status

Name	Color	Meaning	Note
PWR	Lights in green	Normal	---
	Blinks in green	Self-diagnostic test running or initialization in progress during powering on sequence	This test takes approx. 0.5 second.
	Blinks in red	PROFIBUS communications error	The inverter shows <i>er5</i> . ^{*1}
	Lights in red	Hardware error (Card not properly installed or card faulty)	The inverter shows <i>er4</i> .
ERR	Blinks in red	Wrong configuration of PROFIBUS protocol (Discrepancy between PPO type defined by the inverter's function code o30 and the one defined in the PROFIBUS master node) ^{*2}	---
		Wrong configuration of PROFIBUS protocol (The node address is set to 126 or greater.)	The inverter shows <i>er5</i> . ^{*1}
ONL	Lights in green	Online (The card communicates normally on the PROFIBUS network.)	---
	OFF	Not online	---
OFFL	Lights in red	Offline (The card is not connected to PROFIBUS)	---
	OFF	Not offline	---

^{*1} Configuration for ignoring *er5* is possible. For details, refer to Chapter 10, "INVERTER REACTION TO PROFIBUS COMMUNICATIONS ERRORS."

^{*2} PPO (Parameter Process-data Object) type defined in this card should be consistent with that in the PROFIBUS DP master node. To define the PPO type in this card, use the inverter's function code o30; to define that in the master node, use a configuration tool designed for the master node.

For defining the PPO type in the master node, refer to the documentation of the master node.

For details about the PPO type, see Chapter 9, "DETAILS OF PROFIBUS PROFILES." For details about the function code o30, see Chapter 6 "FUNCTION CODE SETTINGS REQUIRED FOR PROFIBUS COMMUNICATION."

3.2 Node Address Switches

The node address switches (SW1 and SW2) on the interface card are rotary ones that are used to specify the PROFIBUS DP communications network node address (station address) of the card. The setting range is from 0 to 99 in decimal. The SW1 specifies a 10s digit of the node address and the SW2, a 1s digit.

The node address can also be specified with the inverter's function code o31. The setting range is from 0 to 125 in decimal. Note that validating the node address specified with the function code o31 requires setting the node address switches to "00."

Example 1: Setting the node address 27 using the node address switches

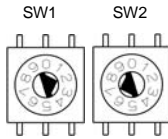

1. When the inverter is powered OFF:
Set SW1 to "2."
Set SW2 to "7."
2. Turn the inverter power ON.
The setting procedure is completed.

Figure 4 Node Address Setting Example 1

Example 2: Setting the node address 125 using the function code o31

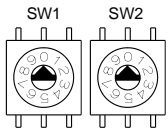

1. When the inverter is powered OFF:
Set both the SW1 and SW2 to "0."
2. Turn the inverter power ON and set the function code o31 data to "125."
3. Turn the inverter power OFF and ON.
The setting procedure is completed.

Figure 5 Node Address Setting Example 2



1. The node address switches should be accessed with all the inverter power (including the auxiliary power) being OFF. Setting these switches with the inverter power being ON requires turning the power OFF and ON to validate the new setting.
2. To validate the node address setting using the function code o31, restart the inverter.
3. Setting the function code o31 data to "126" or greater will cause a data setting error. The ERR LED on the card blinks in red and the inverter issues the alarm code *er5*.

3.3 Terminating Resistor Switch

The PROFIBUS DP communications network requires insertion of line terminating resistors at its end. When the card is mounted in the inverter at the end of the network, turn this switch ON to insert the terminating resistor. No external terminating resistor is required.

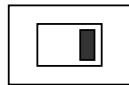

OFF: No insertion of terminating resistor

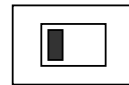

ON: Insertion of terminating resistor

Figure 6 Terminating Resistor Switch

3.4 Terminal Board

This card provides two terminal blocks, one for the PROFIBUS communications and another for grounding (earthing).

For wiring of the terminal blocks, refer to Chapter 5 "WIRING."

3.5 Setting the Transmission Speed (Baud rate)

No transmission speed setting is required on the interface card (slave). Setting the transmission speed in the PROFIBUS DP network master node automatically configures the transmission speed of this card.

Chapter 4 INSTALLATION

⚠ WARNING

Turn the power OFF and wait for at least five minutes for inverters of 40 HP or below, or ten minutes for inverters of 50 HP or above, before starting installation. Further, check that the LED monitor and charge lamp are unlit, and check the DC link circuit voltage between the P (+) and N (-) terminals to be lower than 25 VDC.

Otherwise, electric shock could occur.

⚠ CAUTION

Do not touch any metallic part of the connector for the main unit (CN1) or any electronic component. Otherwise, electronic components may be damaged by static electricity charged in your body. Also, the stain or adhesion of sweat or dust may adversely affect the contact reliability of the connector in the long run.

An accident could occur.

- (1) Remove the covers from the inverter to expose the control printed circuit (Figure 7).

📖 For the removal instructions, refer to the FRENIC-Eco Instruction Manual (INR-SI47-1225-E), Chapter 2, Section 2.3 "Wiring." (For inverters of 50 HP or above, also open the keypad enclosure.)

- (2) Insert four spacers and connector CN1 on the back of the OPC-F1-PDP (Figure 2) into the four spacer holes and Port A (CN4) on the inverter's control printed circuit board (PCB) (Figure 8), respectively.

📌 **Note** Make sure, visually, that the spacers and CN1 are firmly inserted (Figure 9).

- (3) Install the wires for the OPC-F1-PDP.

📖 For wiring instructions, see Chapter 5 "WIRING."

- (4) Put the covers back to their original positions.

📖 For the installation instructions, refer to the FRENIC-Eco Instruction Manual (INR-SI47-1225-E), Chapter 2, Section 2.3 "Wiring." (For inverters of 50 HP or above, also close the keypad enclosure.)

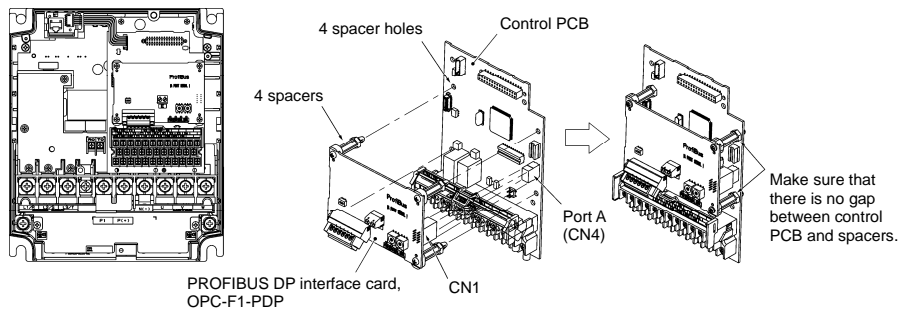

Figure 7 FRN010F1S-2U to
FRN020F1S-2U
(example)

Figure 8 Mounting the Card

Figure 9 Mounting Completed

Chapter 5 WIRING

(1) Use a shielded twist pair cable that complies with the PROFIBUS specifications.

Tip The recommended cable is 6XV1 830-0EH10 manufactured by Siemens AG.

For details about wiring for PROFIBUS, refer to the "Installation Guideline for PROFIBUS DP/FMS" and "Handbook PROFIBUS Installation Guideline" published by the PROFIBUS Organization. It can be downloaded for free from the PROFIBUS Organization's website at:

<http://www.profibus.com/pall/meta/downloads/>

(2) Wiring to the PROFIBUS terminal block (TERM1)

The terminal block uses a 6-pin connector shown in Figure 10. Table 2 shows the pin assignment.

The applicable connector is "MC1.5/6-STF-3.81" manufactured by Phoenix Contact Inc.

Before connecting the PROFIBUS cable to the terminal block, strip the cable wire end and twist the core and shield wires. Figure 11 shows the recommended wire strip length. Table 3 lists the recommended tightening torque of the terminal screws and the wire size.

Table 2 Pin Assignment on TERM1

Pin #	Pin Assignment	Description
1	+5V BUS	Not used.
2	GND BUS	Not used.
3	A-Line	Terminal for the negative (-) line of PROFIBUS cable (green wire)
4	B-Line	Terminal for the positive (+) line of PROFIBUS cable (red wire)
5	Shield *	Terminal for connecting the cable shield
6	RTS	Data transmission control for the repeater (direction control)

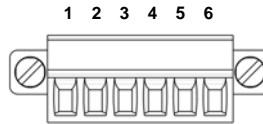

Figure 10 Connectors of the PROFIBUS Terminal Block

* The Shield terminal on the TERM1 and Ground terminal(s) on the TERM2 are connected internally.

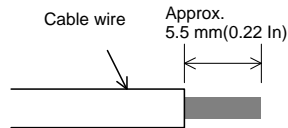

Figure 11 Recommended Strip Length of the PROFIBUS Cable Wire End for Terminal Connection

Table 3 Recommended Tightening Torque of the Terminal Screws and Wire Size for the PROFIBUS Terminal Block

Terminal Screw Size	Tightening Torque	Wire Size
M2	0.22 to 0.25 N·m (0.16 to 0.18 lbf·ft)	AWG28 to AWG16 (0.14 to 1.5 mm ²)

Note Keep the PROFIBUS cable away from the main power supply wires of the inverter and the motor power cable and other devices as far as possible.

(3) Wiring to the ground terminal block (TERM2)

Using a wire, connect either one of the two ground terminals* on the TERM2 to the grounding terminal (⊕G) on the inverter. (*These two terminals on the TERM2 are internally connected.)

Figure 12 shows the recommended wire end strip length for the card connector. Table 4 shows the recommended tightening torque of the terminal screws and its tightening torque, and the wire size.

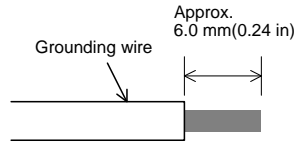

Figure 12 Recommended Strip Length of the Grounding Wire

Table 4 Recommended Tightening Torque of the Terminal Screws and Wire Size for the Ground Terminal Block (TERM2)

Terminal screw size	Tightening torque	Wire size
M3	0.5 to 0.6 N·m(0.37 to 0.44 lbf·ft)	AWG17 to AWG16 (1.0 to 1.5 mm ²)

Note To keep noise immunity high, be sure to connect a grounding wire to the terminal block.

Tip The ground terminal block TERM2 is marked with **E** by its side. "E" signifies earth (ground). The ground terminal(s) on the TERM2 and the Shield terminal on the TERM1 are connected internally, so this connection grounds the shield of the PROFIBUS cable if the inverter is grounded.

(4) Switching the terminating resistor ON/OFF

When the cards are mounted on the inverters at both ends of network, turn the SW3 ON to insert the terminating resistors.

For details, refer to Chapter 3, Section 3.3 "Terminating Resistor Switch."

Chapter 6 FUNCTION CODE SETTINGS REQUIRED FOR PROFIBUS COMMUNICATION

To perform data transmission between the inverter equipped with this card and the PROFIBUS DP master node, configure the function codes listed in Table 5.

Tables 5 and 6 list inverter's function codes related to PROFIBUS DP communication. Configure those function codes if necessary.

For details about function codes, refer to the FRENIC-Eco Instruction Manual (INR-SI47-1225-E), Chapter 5 "FUNCTION CODES" and RS-485 Communication User's Manual (MEH448), Chapter 5, Section 5.2 "Data Formats."

Table 5 Inverter's Function Code Settings Related to PROFIBUS Communications

Function codes	Description	Factory default setting	Function code data	Remarks															
o30 *1	Select PPO type (data format)	0	Available data is: 0, 1, 6 to 255: PPO type 1 2 and 5: PPO type 2 3: PPO type 3 4: PPO type 4	The selected PPO type should be consistent with that of the master node.															
y98 *2	Select run/frequency command source	0	Available data is: <table border="1"> <thead> <tr> <th></th> <th>Frequency command</th> <th>Run command</th> </tr> </thead> <tbody> <tr> <td>0</td> <td>Inverter</td> <td>Inverter</td> </tr> <tr> <td>1</td> <td>PROFIBUS</td> <td>Inverter</td> </tr> <tr> <td>2</td> <td>Inverter</td> <td>PROFIBUS</td> </tr> <tr> <td>3</td> <td>PROFIBUS</td> <td>PROFIBUS</td> </tr> </tbody> </table>		Frequency command	Run command	0	Inverter	Inverter	1	PROFIBUS	Inverter	2	Inverter	PROFIBUS	3	PROFIBUS	PROFIBUS	If there is no special problem with your system, setting y98 = 3 is recommended.
	Frequency command	Run command																	
0	Inverter	Inverter																	
1	PROFIBUS	Inverter																	
2	Inverter	PROFIBUS																	
3	PROFIBUS	PROFIBUS																	

*1 After setting up the function code o30, turn the inverter power OFF and ON to validate the new setting.

For details about the function code o30, refer to Chapter 9 "DETAILS OF PROFIBUS PROFILES."

*2 In addition to y98, the FRENIC-Eco has other function codes related to the run/frequency command source. Setting up those codes realizes more precise selection of the command sources. For details, refer to the descriptions of H30 and y98 in the FRENIC-Eco Instruction Manual (INR-SI47-1225-E), Chapter 5 "FUNCTION CODES."

Table 6 Other Related Function Codes

Function codes	Description	Factory default setting	Function code setting range	Remarks
o27 *1	Select the inverter's operation mode to apply when a PROFIBUS communications error occurs.	0	0 to 15	
o28 *1	Set the operation timer to apply when a PROFIBUS communications error occurs.	0.0 s	0.0 s to 60.0 s	
o31 *2	Set the PROFIBUS network node address.	0	0 to 255 (Setting range: 0 to 125)	Valid only when both SW1 and SW2 are set to "00." Setting 126 or greater causes an error, flashing the ERR LED and issuing an <i>er5</i> .
o40 to o43 *3	Assign the function code writing data cyclically.	0 (No assignment)	0000 to FFFF (hex)	Valid only when PPO type 2 or 4 is selected.
o48 to o51 *3	Assign the function code reading data cyclically.	0 (No assignment)	0000 to FFFF (hex)	
W90	Show the software version of the PROFIBUS interface card on the LED monitor.	Depends on the card	--- (Only for monitoring)	4-digit decimal If the version is V.1.23, the LED shows "0123."

*1 For details about function codes o27 and o28, refer to Chapter 10 "INVERTER REACTION TO PROFIBUS COMMUNICATIONS ERRORS."

*2 For details about the function code o31, refer to Chapter 3, Section 3.2 "Node Address Switches."

*3 For details about function codes o40 to o43 and o48 to o51, refer to Chapter 9, Section 9.2 (4) "PCD1 to PCD4."

Chapter 7 ESTABLISHING A PROFIBUS COMMUNICATIONS LINK

This chapter guides you to establish a PROFIBUS DP communications link between the PROFIBUS DP master node and this card (slave node).

Follow the steps below.

Step 1 Configuring the PROFIBUS DP master node equipment

Step 2 Configuring this card and inverter's function codes

Step 3 Powering ON the inverter and initiating the PROFIBUS data transaction

Each of the above steps is detailed below.

Step 1 Configuring the PROFIBUS DP master node equipment

Step 1.1: Specify the master node address (station address) and baud rate.

Step 1.2: Register this card to the master node using the GSD file prepared for the card.

Step 1.3: Choose a PPO type (data format) to be applied to the registered card, from PPO type 1 to PPO type 4.

 For details about the configuration of the PROFIBUS DP master node equipment, refer to the user's manual or documentations of your master equipment.

 For details about PPO types, refer to Chapter 9 "DETAILS OF PROFIBUS DP PROFILES."

IMPORTANT

A GSD file, which is required for registering the PROFIBUS DP interface card to the PROFIBUS master node, does not come with the card. It is available as a free download from our website at:

<http://web1.fujielectric.co.jp/Kiki-Info-EN/User/index.html>

(Fuji Electric FA Components & Systems Co., Ltd. Technical Information site)

Before downloading, you are requested to register as a member (free of charge).

Step 2 Configuring this card and inverter's function codes

Step 2.1: Specify the node address that must be identical with the card address registered to the master node.

Step 2.2: Set up the data of inverter function codes o27 and o28, if needed.

Step 2.3: Choose a PPO type from PPO type 1 to PPO type 4, using the inverter's function code o30.

The PPO type must be identical with the one selected for the master node. After changing the data of the function code o30, be sure to turn the inverter power OFF and ON.

 For details about function codes o27 and o28, refer to Chapter 10 "INVERTER REACTION TO PROFIBUS COMMUNICATIONS ERRORS."

Step 3 Powering ON the inverter and initiating the PROFIBUS data transaction

When the inverter equipped with this card and the PROFIBUS DP master node are correctly set up, turning the inverter OFF and ON automatically establishes a PROFIBUS communications link, enabling the data transaction between them. The PWR and ONL LEDs on the card light in green.

Send run and frequency commands from the master to this card.

 For specific data formats and data transaction, refer to Chapter 8 "QUICK SETUP GUIDE FOR RUNNING THE INVERTER" and Chapter 9 "DETAILS OF PROFIBUS DP PROFILES."

 For the wiring, refer to Chapter 5 "WIRING."

Chapter 8 QUICK SETUP GUIDE FOR RUNNING THE INVERTER

This chapter provides a quick setup guide for running the inverter from a PROFIBUS DP master node according to the simplest data format (PPO type 3), taking an operation example. PPO type 3 is a simple format dedicated to inverter's run and frequency commands.

Tip The description of PPO type 3 in this chapter can apply to other PPO types, except the format assignment maps.

To simplify the description, this chapter confines the description to running of an inverter. For more information, refer to Chapter 9 "DETAILS OF PROFIBUS DP PROFILES."

8.1 Before Proceeding to Data Exchange

(1) At the PROFIBUS DP master node, select PPO type 3 for this interface card.

For the setting procedure of PPO types at the PROFIBUS DP master node, refer to the user's manual of your master node equipment.

(2) Set function codes of your inverter as follows.

F03 = 60 (Maximum frequency in Hz), y98 = 3 (Validate frequency and run commands from PROFIBUS), and o30 = 3 (Select PPO type 3)

Also set the data of function codes o27 and o28, if needed.

After settings are completed, turn the inverter power OFF and ON to validate the new settings.

For details about function codes o27 and o28, refer to Chapter 10 "INVERTER REACTION TO PROFIBUS COMMUNICATIONS ERRORS."

8.2 Data Transaction Examples in Running an Inverter

Before providing data transaction examples, this section shows the data frame formats of PPO type 3. The following descriptions are based on these formats.

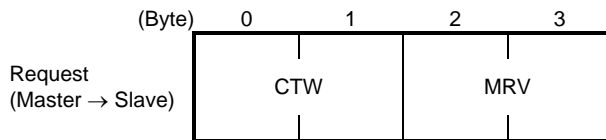

CTW: Control word (2 bytes) that sends a run command. The LSB determines ON/OFF of the run command.

MRV: Sends a frequency command that is expressed relative to the maximum frequency (defined by F03 in Hz) being assumed as 4000hex.

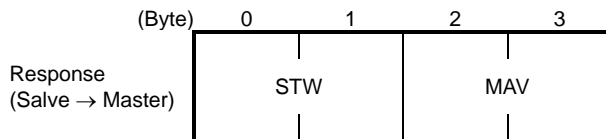

STW: Status word (2 bytes) that sends the running status of the inverter to be monitored at the master node.

MAV: Sends the current output frequency of the inverter to be monitored at the master node, which is expressed relative to the maximum frequency (defined by F03 in Hz) being assumed as 4000hex.

Given below is a PROFIBUS DP communication sample in which the master node runs the inverter in the forward direction in 60 Hz.

(1) Turning the inverter power ON initiates PROFIBUS DP communication. Immediately after the power is ON, the data in the request/response frames is as follows.

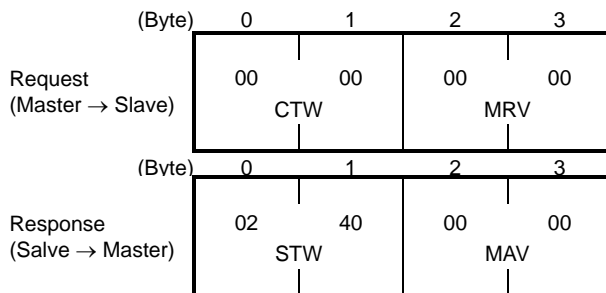

STW: Data 02 indicates that frequency and run commands from PROFIBUS are enabled. Data 40 indicates that the inverter is not ready to turn a run command ON.

MAV: Data 0000 means that the current output frequency is 0 Hz.

(2) In step (1), the inverter is not ready to turn a run command ON as shown in STW.

First, enter the request data "04 7E" to CTW, to make the inverter ready to turn a run command ON. In the example below, the frequency command 60 Hz (maximum frequency being assumed as 4000hex) is entered to MRV at the same time.

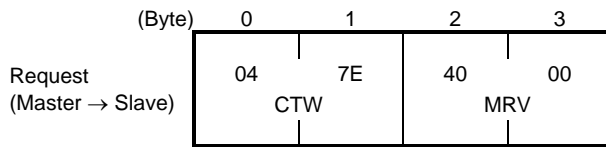

CTW: Data 04 enables the contents in this frame. Data 7E requests the inverter to get ready to turn a run command ON.

MRV: The frequency command is 4000hex (= Maximum frequency defined by F03 in Hz).

In response to the above request, this interface card returns the following response to the master node.

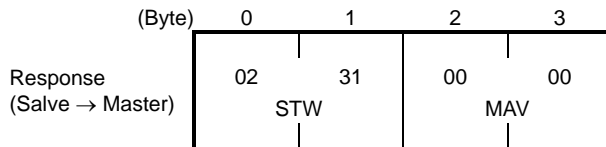

STW: Data 02 indicates that frequency and run commands from PROFIBUS are enabled. Data 31 indicates that the inverter is ready to turn a run command ON.

MAV: The current output frequency is 0 Hz.

(3) Since the inverter has been ready to turn a run command ON, enter run command data "04 7F" to CTW.

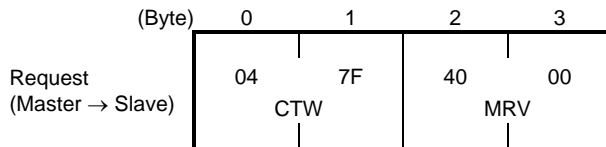

CTW: Data 04 enables the contents in this frame. Data 7F requests the inverter to turn a run command ON.

MRV: The frequency command is 4000hex (= Maximum frequency defined by F03 in Hz).

In response to the above request, the inverter starts running the motor. The card returns the following response to the master node.

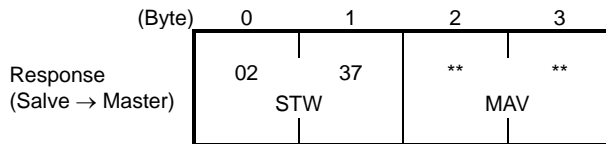

STW: Data 02 indicates that frequency and run commands from PROFIBUS are enabled. Data 37 indicates that the inverter is running.

MAV: The output frequency is accelerating.

(4) To stop the inverter, enter data "04 7E" to CTW.

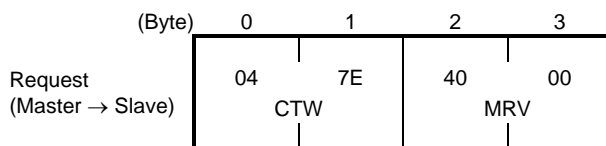

CTW: Data 04 enables the contents in this frame. Data 7E requests the inverter to turn the run command OFF.

MRV: The frequency command is 4000hex (= Maximum frequency defined by F03 in Hz).

In response to the above request, the inverter decelerates to a stop. The card returns the following response to the master node.

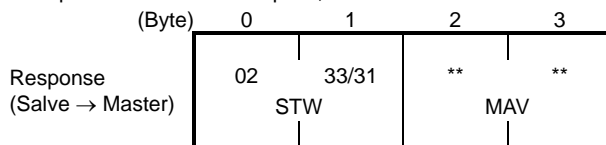

STW: Data 02 indicates that frequency and run commands from PROFIBUS are enabled. Data 33 indicates that the inverter is decelerating, and data 31 indicates that the inverter is ready to turn a run command ON (when the inverter is stopped).

MAV: The output frequency is decreasing.

- (5) To restart running the inverter, enter data "04 7F" to CTW. To run the inverter in the reverse direction, enter data "0C 7F" instead. The example below specifies "Run reverse at the frequency of 30 Hz (2000hex)."

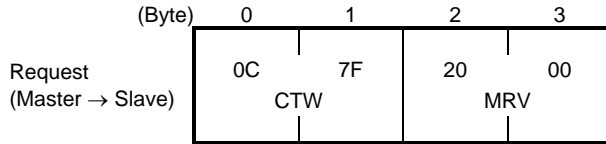

CTW: Data 0C enables the contents in this frame and requests the inverter to turn a run reverse command ON. Data 7F requests the inverter to turn a run command ON.

MRV: The frequency command is 2000hex (Frequency (Hz) = $F03 \times 2000\text{hex}/4000\text{hex}$).

In response to the above request, the inverter starts running the motor in the reverse direction. The example below shows a response indicating that the inverter has reached the commanded frequency level in the reverse direction.

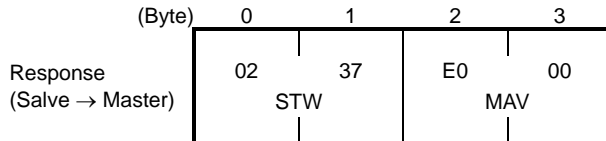

STW: Data 02 indicates that frequency and run commands from PROFIBUS are enabled. Data 37 indicates that the inverter is running.

MAV: The current output frequency is E000hex (2's complement expression of 2000hex (Frequency = $F03 \times -2000\text{hex}/4000\text{hex}$)).

- (6) Entering a negative value to MRV also allows the inverter to run in the reverse direction. The example below enters E000hex, 2's complement of 2000hex.

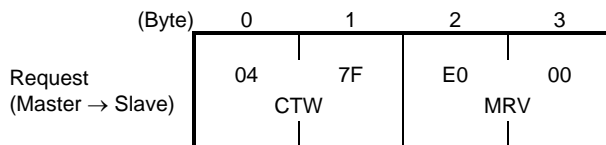

CTW: Data 04 enables the contents in this frame. Data 7F requests the inverter to turn a run command ON.

MRV: The frequency command is E000hex (-2000hex) (Frequency = $F03 \times -2000\text{hex}/4000\text{hex}$).

In response to the above request, the inverter starts running the motor in the reverse direction. The example below shows a response indicating that the inverter has reached the commanded frequency level in the reverse direction.

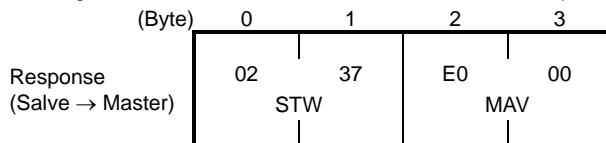

STW: Data 02 indicates that frequency and run commands from PROFIBUS are enabled. Data 37 indicates that the inverter is running.

MAV: The current output frequency is E000hex (Frequency = $F03 \times -2000\text{hex}/4000\text{hex}$).

- (7) If any trip occurs in the inverter, remove the trip factor and then enter data "04 80" to CTW to cancel the trip. After the trip is cancelled, enter data "04 00." (Note: The MSB in the 2nd byte (Byte 1) acts as a trip cancellation bit.)

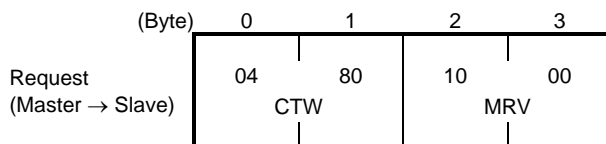

CTW: Data 04 enables the contents in this frame. Data 80 requests canceling of the trip.

MRV: The frequency command is 1000hex (Frequency = $F03 \times 1000\text{hex}/4000\text{hex}$).

Canceling a trip returns the inverter to the state immediately after the power is turned ON. To restart operation using PROFIBUS network, go back to step (2).

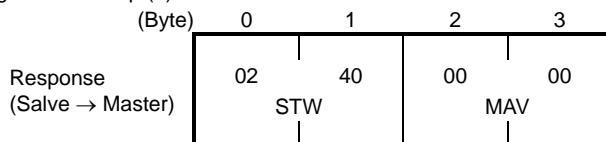

STW: Data 02 indicates that frequency and run commands from PROFIBUS are enabled. Data 37 indicates that the inverter is running.

MAV: The current output frequency is 0000hex.

Chapter 9 DETAILS OF PROFIBUS PROFILES

The interface card supports PROFdrive V2 of a motor control profile which is instituted by the PROFIBUS Organization. This chapter describes the PROFdrive profile.

9.1 Description of PPO Types Supported

The PROFdrive profile defines several data formats called PPO (Parameter Process-data Object). This interface card supports four PPO types shown in Figure 13. Select a PPO type to apply to the card using the function code o30 (see Table 7). Table 8 lists the features of these PPO types. Tables 9 and 10 list the parts in the PPO.

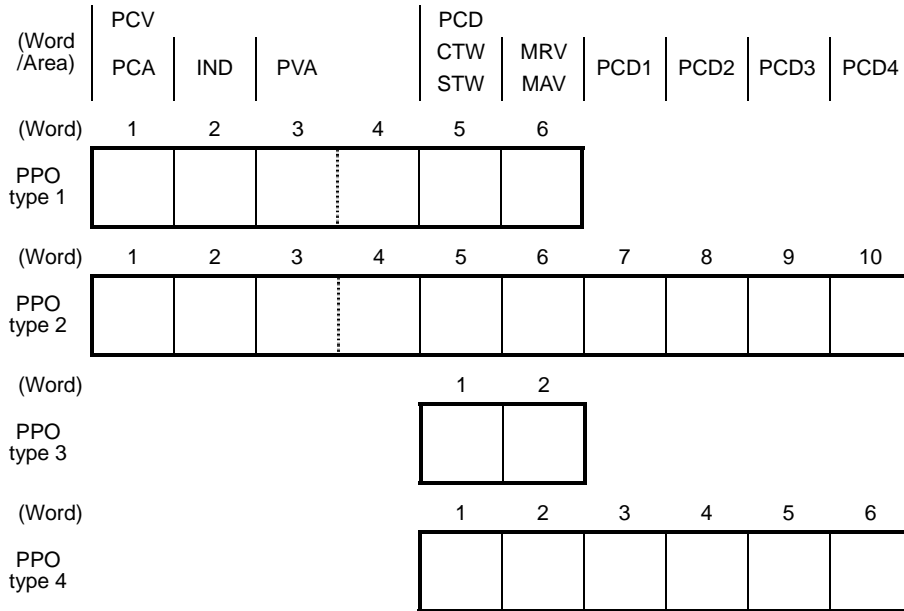

Figure 13 Data Formats of PPO Types Supported

Table 7 Choice of PPO Type Using the Inverter's Function Code o30

Data of o30	PPO	Remarks
0, 1, 6 to 255	PPO type 1	Factory default PPO type
2, 5	PPO type 2	
3	PPO type 3	
4	PPO type 4	

Note Turn the inverter power OFF and ON after setting the function code o30 to validate the new setting.

Table 8 Features of PPO Types

PPO	Features
PPO type 1	Most typical data format that supports run command/running status monitor, frequency command/output frequency monitor, and on-demand accesses to inverter's function codes.
PPO type 2	Fully functional data format that supports run command/running status monitor, frequency command/output frequency monitor, on-demand accesses to inverter's function codes, and cyclic access to up to four inverter's function codes previously specified.
PPO type 3	Simplified data format specialized for defining run command/running status monitor and frequency command/output frequency monitor.
PPO type 4	Data format that supports cyclic access to up to four inverter's function codes previously specified, in addition to the features of PPO type 3.

Table 9 Parts in PPO

Parts	Description
PCD	Parameter area used for cyclic data communication with the PROFIBUS DP master node. Run command/running status monitor and frequency command/output frequency monitor can be assigned to this area. PPO type 2 and type 4 additionally can assign arbitrary inverter's function codes to this area, enabling cyclic data writing and reading, each with up to four function codes.
PCV	Parameter area used for an on-demand access to the parameter (inverter's function codes and PROFIdrive specific parameters). PPO type 1 and type 2 support this area.

Table 10 Words in PCV and PCD Parts

Parts	Words	Function	Description
PCD	CTW/STW	Request	CTW: Control word that sends a run command from the master to the slave.
		Response	STW: Status word that returns the inverter's running status from the slave to the master as a response.
	MRV/MAV	Request	MRV: Word area that sends a frequency command expressed relative to the maximum frequency (defined by F03 in Hz) being assumed as 4000hex, from the master to the slave.
		Response	MAV: Word area that returns the current inverter's output frequency expressed relative to the maximum frequency (defined by F03 in Hz) being assumed as 4000hex, from the slave to the master.
	PCD1	Request	Word area that writes data of the inverter's function code specified by o40.
		Response	Word area that cyclically monitors data of the inverter's function code specified by o48.
	PCD2	Request	Word area that writes data of the inverter's function code specified by o41.
		Response	Word area that cyclically monitors data of the inverter's function code specified by o49.
	PCD3	Request	Word area that writes data of the inverter's function code specified by o42.
		Response	Word area that cyclically monitors data of the inverter's function code specified by o50.
	PCD4	Request	Word area that writes data of the inverter's function code specified by o43.
		Response	Word area that cyclically monitors data of the inverter's function code specified by o51.
PCV	PCA	Request	Word area that specifies the parameter (for the inverter's function code and PROFIBUS parameter) and access method to the parameter such as "write" and "read."
		Response	Word area that returns the parameter specified by the request above and the access result as a response.
	IND	Request /Response	Word area that is used to specify indexes of array parameters and inverter's function code numbers.
	PVA	Request /Response	Word area that shows the parameter value written or read.

For details about inverter's function codes o40 to o43 and o48 to o51, refer to Section 9.2 (4) "PCD1 to PCD4."

Tip The "Request" and "Response" denote data transfer from the PROFIBUS master node to the inverter (slave node) equipped with this interface card and that from the inverter to the PROFIBUS master node, respectively.

9.2 PCD Word Area

The PCD word area controls the cyclic data transfer between the PROFIBUS DP master node and the inverter (slave node) equipped with this interface card. It consists of CTW (run command), STW (running status monitor), MRV (frequency command), MAV (output frequency monitor), and PCD1 to PCD4 (cyclic accesses up to four inverter's function codes previously assigned) word areas.

(1) CTW (Control word)

CTW is a word area for controlling the data transfer of run command and its related ones from the PROFIBUS DP master node to the inverter (slave node) equipped with this interface card.

(bit	15	14	13	12	11	10	9	8	7	6	5	4	3	2	1	0
)	b15	b14	b13	b12	b11	b10	b9	b8	b7	b6	b5	b4	b3	b2	b1	b0

Table 11 Bit Definition in CTW

Bit	Command/Status	False (0)	True (1)
b0	ON/OFF	Turn a run command OFF	Turn a run command ON
b1	ON2/OFF2	OFF2: Coast to stop	ON2: Request the inverter to be ready for turning a run command ON (1)
b2	ON3/OFF3	OFF3: Stop command following the deceleration time specified by the function code H56	ON3: Request the inverter to be ready for turning a run command ON (2)
b3	Enable operation	Shut down the inverter output	Enable inverter operation
b4	Enable ramp generator	Fix the inverter output frequency at 0 Hz	Enable the ramp frequency generator (RFG)
b5	Unfreeze ramp generator	Freeze the RFG with the current output frequency fixed	Unfreeze RFG command
b6	Enable setpoint	Disable	Enable ON-bit
b7	ALM RST	Do not reset alarm	Reset alarm (Resetting an alarm makes the card unready to turn a run command ON.)
b8, b9	Not used.	---	---
b10	Enable PCD	Ignore data entered in the PCD area (CTW+MRV)	Enable data entered in the PCD area (CTW+MRV)
b11	Run direction	Run in the forward direction	Run in the reverse direction
b12 to b15	Not used.	---	---

 For the use under the usual operation conditions, setting b1 through b6 and b10 to "1" could not cause any problem.

 The PROFIdrive profile controls an inverter, following the status transition in the interface card. It means that only turning a run command ON cannot run the inverter. After the inverter undergoes the status transition scheduled by the PROFIdrive profile and enters the appropriate state, a run command should be turned ON. The status word STW described in the next section informs you of the current status of the interface card.

 For the status transition condition of the PROFIdrive profile, refer to Section (2) "STW (status word)" and Figure 14 on the following pages.

 If you do not need any strict control with the status transition, follow the procedure given in Chapter 8 "QUICK SETUP GUIDE FOR RUNNING THE INVERTER."

(2) STW (Status word)

STW is a word area for monitoring the inverter's running status.

📖 STW indicates the status transition of the PROFIdrive. The status transition details are shown in Figure 14.

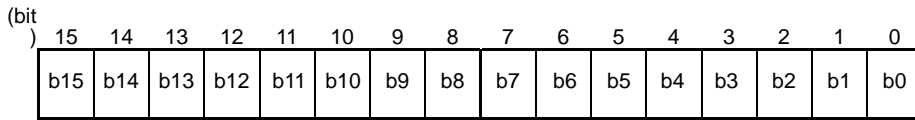

Table 12 Bit Definition in STW

Bit	Status	False (0)	True (1)
b0	Ready to switch ON	Not ready to turn a run command ON	Ready to turn a run command ON
b1	Ready to run	Not ready to run	Ready to run
b2	Running state	Running disabled	Running
b3	ALM	No inverter trip present	Inverter being tripped
b4	ON2/OFF2	OFF2: b1 in CTW is "0"	ON2: b1 in CTW is "1"
b5	ON3/OFF3	OFF3: b2 in CTW is "0"	ON3: b2 in CTW is "1"
b6	Run command ON inhibited	Ready to turn a run command ON (logical negation of b0)	Not ready to turn a run command ON (logical negation of b0)
b7	Not used.	---	---
b8, b9	FAR	Not reached the reference frequency	Reached the reference frequency
b10	R/L	Both frequency and run commands from PROFIBUS are invalid	Either one of frequency and run commands from PROFIBUS is valid
b11	FDT	Output frequency has not reached the level specified by the function code E31	Output frequency has reached or exceeded the level specified by the function code E31
b12 to b15	Not used.	---	---

Figure 14 illustrates a status transition diagram of the PROFIdrive profile.

Immediately after the inverter power is turned ON, the status first moves to S1 "Not ready to turn a run command ON." Bit manipulation in CTW shifts the status to S2 "Ready to turn a run command ON," S3 "Ready to run" and finally S4 "Running" in sequence. In S4 state, the inverter enters the running state. Turning a run command OFF in S4 state shifts the status to S5 "Turn a run command OFF." After the motor stops, the status moves to S2 or S1 state.

Note In Figure 14, to simplify the description, values of Bit 4 to Bit 6 and Bit 10 in CTW are always "1." If any one of these bit values is not "1," the inverter will not enter the running state even if the status transition properly proceeds.

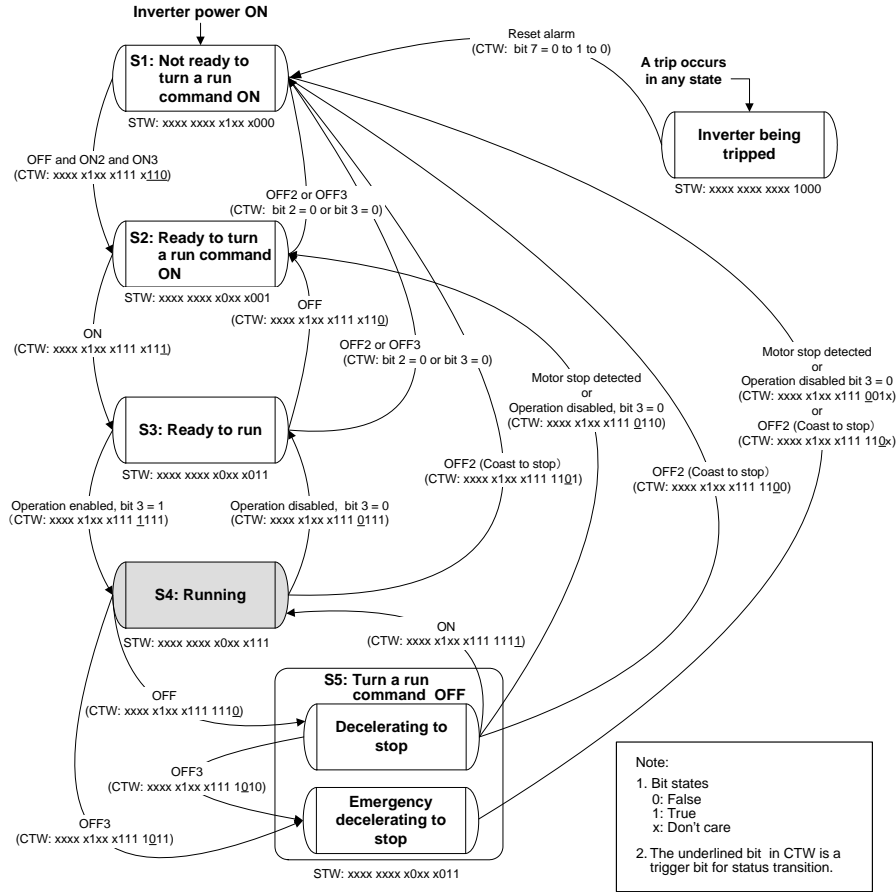

Figure 14 Status Transition Diagram of PROFIdrive Profile

(3) MRV (frequency command) and MAV (output frequency)

MRV and MAV are word areas for setting a frequency command and monitoring an output frequency, respectively.

MRV: Frequency command word area that sends a frequency command from the PROFIBUS DP master node to an inverter (slave node).

MAV: Output frequency monitoring word area that returns the current inverter's output frequency to the PROFIBUS DP master node as a response from the inverter (slave node).

In each word, the frequency is expressed relative to the maximum frequency (defined by F01 in Hz) being assumed as 4000hex. The conversion expression is shown below.

$$\text{MRV or MAV} = \frac{\text{Frequency (Hz)}}{\text{Function code F03 (Hz)}} \times 4000\text{hex} \quad \text{or} \quad \text{Frequency (Hz)} = \text{Function code F03 (Hz)} \times \frac{\text{MRV or MAV}}{4000\text{hex}}$$

Tip A negative value is expressed by 2's complement of 4000hex. When the inverter is running in the *reverse* direction, the value of MAV (output frequency) is a negative value. Setting a negative value to MRV (frequency command) causes even a run *forward* command to run the motor in the *reverse* direction.

(4) PCD1 to PCD4

PCD1 to PCD4 are word areas exclusively supported by PPO type 2 and type 4. They enable cyclic write request and read (monitor) response to/from up to four inverter's function codes previously specified for each of PCD1 to PCD4.

Note Values written and read to/from the specified function codes are in the same data format as defined in individual inverter's function codes.

For the formats of inverter's function codes, refer to the RS-485 Communication User's Manual (MEH448), Chapter 5, Section 5.2 "Data Formats."

To assign inverter's function codes to PCD1 to PCD4 words, use function codes o40 to o43 and o48 to o51 as listed in Table 13. Table 14 on the next page shows how to use these function codes.

Table 13 Function Codes to Assign Inverter's Function Codes to PCD1 to PCD4 Words

	PCD area	Function codes	Remarks
Request (Write a function code)	PCD1	o40	Also assignable by PNU915, index 1 *
	PCD2	o41	Also assignable by PNU915, index 2 *
	PCD3	o42	Also assignable by PNU915, index 3 *
	PCD4	o43	Also assignable by PNU915, index 4 *
Response (Monitor a function code)	PCD1	o48	Also assignable by PNU916, index 1 *
	PCD2	o49	Also assignable by PNU916, index 2 *
	PCD3	o50	Also assignable by PNU916, index 3 *
	PCD4	o51	Also assignable by PNU916, index 4 *

* PNU915 and PNU916 refer to PROFIdrive specific parameters. For details, refer to Section 9.3 (4) "PROFIdrive specific parameters."

For details of assignment of inverter's function codes using function codes o40 to o43 and o48 to o51, refer to the descriptions on the next page.

To assign an inverter's function code to PCD1 to PCD4 word areas using function codes o40 to o43 and o48 to o51, enter four digit hexadecimal to specify the function code group and number as listed in Table 14.

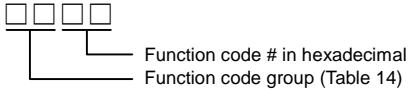

Table 14 Function Code Group Conversion Table

Function code group	Group number		Function code name	Function code group	Group number		Function code name
S	2	02hex	Command/function data	o	10	0Ahex	Option functions
M	3	03hex	Monitor data	J	14	0Ehex	Application functions
F	4	04hex	Fundamental functions	y	15	0Fhex	Link functions
E	5	05hex	Extension terminal functions	W	16	10hex	Monitor data 2
C	6	06hex	Control functions	X	17	11hex	Alarm 1
P	7	07hex	Motor parameters 1	Z	18	12hex	Alarm 2
H	8	08hex	High performance functions	---	---	---	---

Example for F26 F ⇒ Function code group 04hex }
 26 ⇒ Function code number 1Ahex } "041A"

- Note**
- After setting up function codes o40 to o43 and o48 to o51, turn the inverter power OFF and ON to validate the new setting.
 - If a same function code is assigned to the PCD areas using function codes o40 to o43, the function code assigned by the o code with the youngest number takes effect and other assignments will be ignored.
 - Inverter's communication-related function codes S01 and S05 act as a reading specific code in this interface card. Therefore, assigning these codes to a PCD word area as a write request will be ignored.
 Bits in the function code S06 are writable except bit 0 and bit 1. Data written in bit 0 and bit 1 will be ignored.

For details about inverter's communication-related function codes S01, S05 and S06, refer to the RS-485 Communication User's Manual (MEH448), Chapter 5, Section 5.1 "Communications Dedicated Function Codes."

9.3 PCV Word Area

The PCV word area controls an on-demand access to parameters (inverter's function codes and PROFIdrive specific parameters). It is supported by PPO type 1 and type 2. Its structure is shown below.

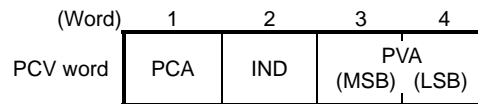
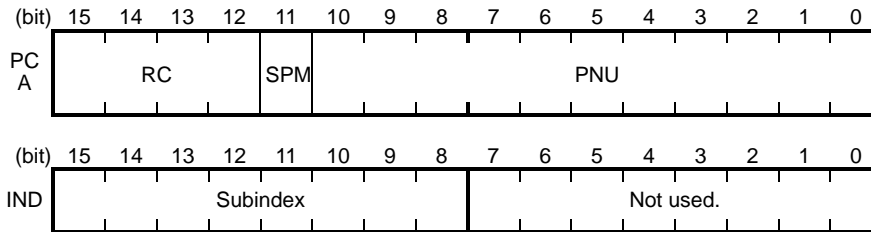

Figure 15 Structure of PCV Word Area

(1) PCA and IND

These two word areas specify a parameter. Their structures are shown below.



RC: Request code/response code (See Table 15.)

SPM: Not used. Fixed at "0."

PNU: Parameter number to be accessed

Subindex: Inverter's function code number (numeric following a function code group) or an index number of array PROFIdrive specific parameters.

Tip To specify an inverter's function code, use PNU and Subindex areas. Enter "Function code group + 100hex" (see Table 14) to the PNU area, and the function code number to the Subindex area.

Info For how to specify and read/write an inverter's function code, refer to Section 9.3 (3) "Access to inverter's function codes and PROFIdrive specific parameters."

Table 15 RC Part

RC part	Request/response	Descriptions
0	Request (Master → Slave)	No request
1		Read parameter value
2		Write parameter value in word
3 to 5		Not used.
6		Read array parameter value
7		Write array parameter in array word
8		Not used.
9		Read element count of array parameter
10 to 15		Not used.
0		Response (Slave → Master)
1	Parameter value in word sent normally	
2, 3	Not used.	
4	Parameter value in array word sent normally	
5	Not used.	
6	Normal response to the request of array element count	
7	Transmission error (Error code stored in PVA)*	
8 to 15	Not used.	

* For error codes and information, see Table 16.

Table 16 List of Error Codes for Parameter Access Errors

RC part	Error code stored in PVA word	Error information
7	0	Nonexistent parameter specified
	1	Parameter value writing inhibited
	2	Specified parameter value out of range
	3	Invalid Subindex specified
	4	Specified parameter not array
	11	Parameter write-protect error during inverter running or digital input terminal (for run command) being ON
	17	Read process not executable
	101	Link priority error
	102	Inverter communications error (<i>er4</i>)
	104	Busy error during parameter writing

(2) PVA word area

PVA is a two-word area that represents write/read parameter values. This interface card uses the lower one word (the fourth word counted from the PCV word head).

To write a parameter value into an inverter (slave node), enter the value to the master node and send the word to the slave. To read a parameter value, refer to this area of the slave node in response to the previous request. If a parameter access error occurs (Response to RC part is "7"), the slave node outputs an error code (Table 16) to this area and returns the response to the master node.

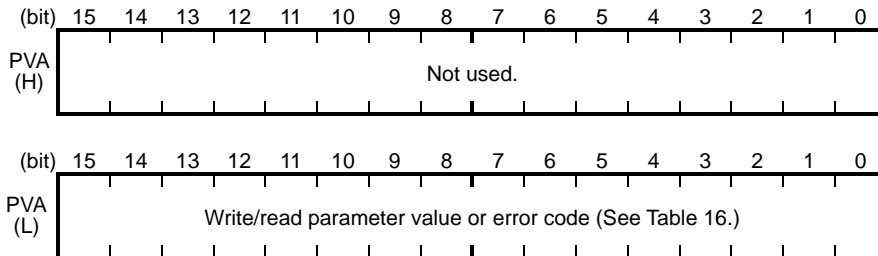

(3) Access to inverter's function codes and PROFIdrive specific parameters

1) Specify the target parameter to be accessed using PNU and Subindex areas (see Figure 16).

When specifying an inverter's function code, enter the numeral of "Function code group number + 100hex" (see Table 14) to the PNU area, and "Function code number" to the Subindex area. For example, enter "104 01" for F01.

2) Specify how to access the specified parameter, for example, Write or Read, in the RC area. For details about the RC area, see Table 15.

3) To write a parameter value, enter the write data into the PVA lower area and send the word to the slave node. To read a parameter value from the slave, refer to the PVA lower area in the response from the slave node. If a parameter access error occurs, the RC part of the response is filled with "7" and the PVA area contains one of the error codes listed in Table 16.

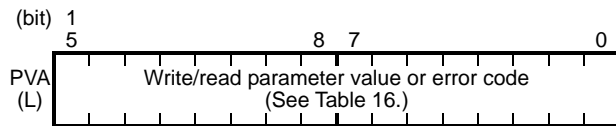
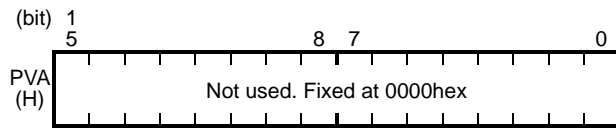
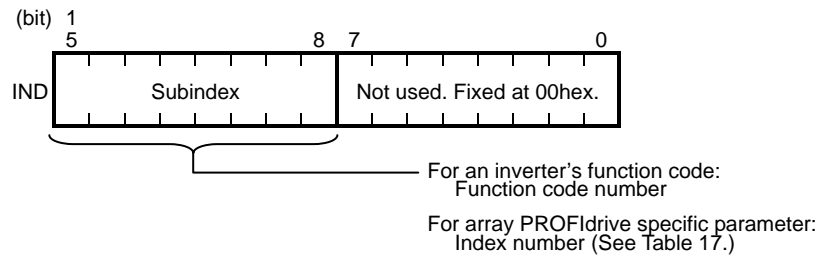
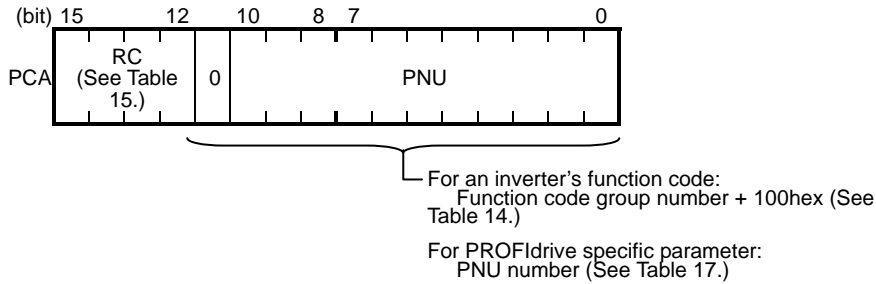

Figure 16 How to Access Parameters

Values written and read to/from the specified function codes are in the same data format as defined in individual inverter's function codes. For the formats of inverter's function codes, refer to the RS-485 Communication User's Manual (MEH448), Chapter 5, Section 5.2 "Data Formats."

Note Inverter's communication-related function codes S01 and S05 act as a reading specific code in this interface card. Therefore, assigning these codes to a PCD word area as a write request will be ignored.

Bits in the function code S06 are writable except bit 0 and bit 1. Data written in bit 0 and bit 1 will be ignored.

For details about inverter's communication-related function codes S01, S05 and S06, refer to the RS-485 Communication User's Manual (MEH448), Chapter 5, Section 5.1 "Communications Dedicated Function Codes."

The actual parameter access examples are given on the following pages.

Example 1: Writing data "15" to the inverter's function code F26

- 1) Send the request to write data "15" to the inverter's function code F26, from the master node to the slave node (inverter)
 - RC = 2hex → Write parameter value (word).
 - PNU = 104hex, Subindex = 1Ahex → Specify F26 (Function code group number 04h + 100hex = 104hex, Function code number = 1Ahex).
 - PVA=0000 000F(hex) → Enter parameter value 15 (= 000Fhex).

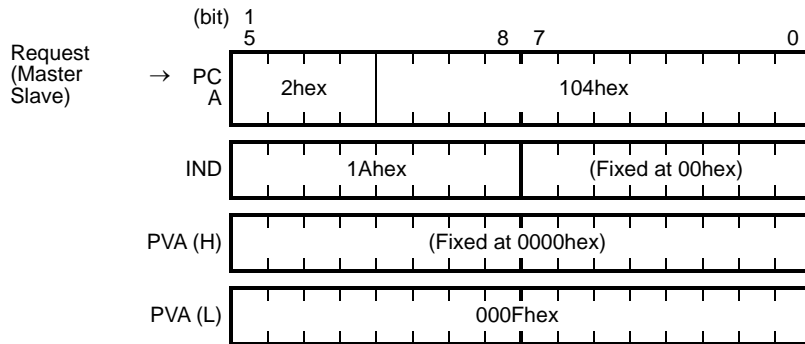

- 2) Response example sent from the card (normal response from the slave node)
 - RC = 1hex → Requested parameter value is normally returned.
 - PNU = 104hex, Subindex = 1Ahex → Accessed parameter is function code F26.
 - PVA = 0000 000Fhex → Parameter value written is 15.

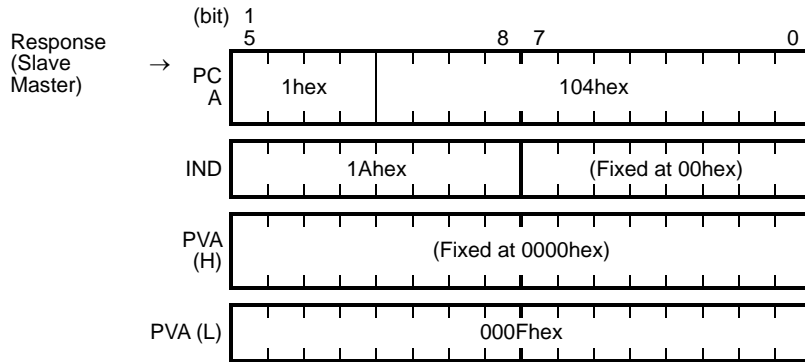

- 3) Response example for the write data error (Specified parameter value out of range)
 - RC = 7hex → Parameter value transmission error.
 - PNU = 104hex, Subindex = 1Ahex → Accessed parameter is function code F26.
 - PVA = 0000 0002hex → Error code 2 (Specified parameter value out of range)

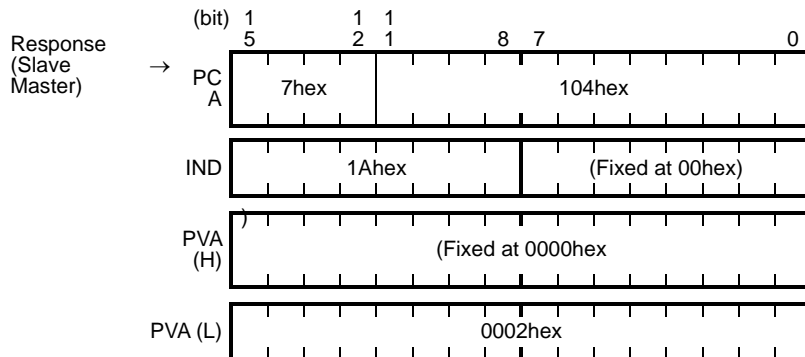

Example 2: Reading (monitoring) data from the inverter's function code y98

- 1) Send the request to read data from the function code y98, from the master node to the slave node.
 RC = 1hex → Read parameter value.
 PNU = 10Fhex, Subindex = 62hex → Specify y98 (Function code group number 0Fhex + 100hex = 10Fhex, Function code number = 62hex)
 PVA = 0000 0000hex → No entry required for PVA.

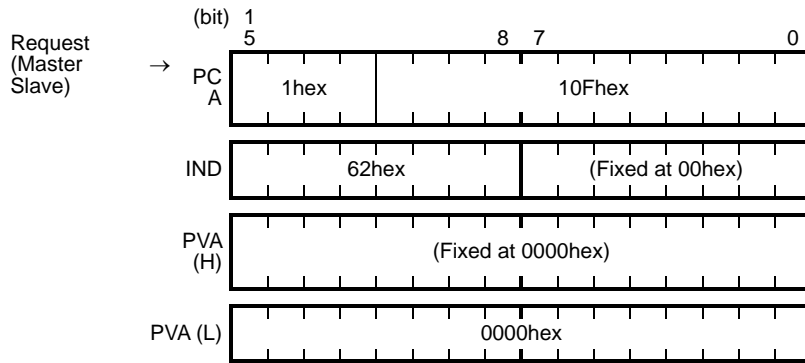

- 2) Response example sent from the card (normal response from the slave node)
 RC = 1hex → Requested parameter value is normally returned.
 PNU = 10Fhex, Subindex = 62hex → Accessed parameter is function code y98.
 PVA = 0000 0003hex → Parameter value read is 3.

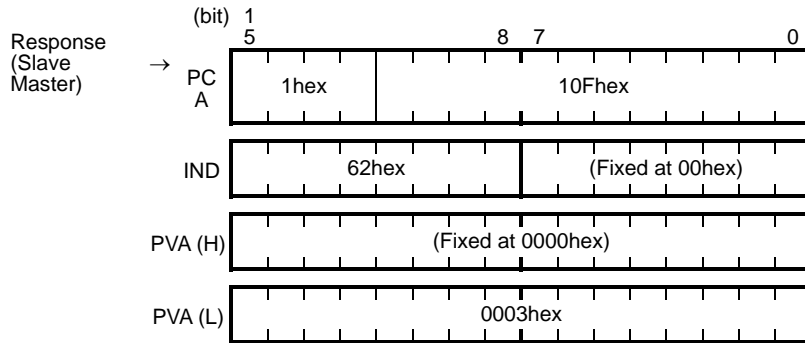

- 3) Response example for the read data error (Specified function code does not exist)
 RC = 7hex → Parameter transmission error.
 PNU = 10Fhex, Subindex = 64hex → Accessed parameter is function code y100.
 PVA = 0000 0000hex → Error code 0 (Nonexistent parameter specified)

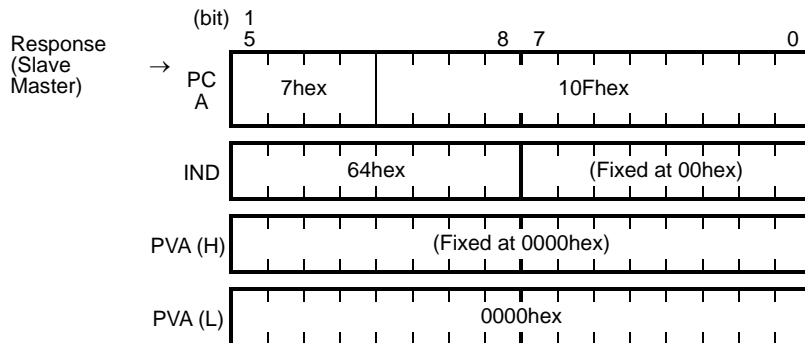

Example 3: Reading from an array PROFIdrive specific parameter PNU947 (Alarm history)

- 1) Send the request to read PNU947 from the master node to the slave node. The example below reads Index 1.
 RC = 6hex → Read an array parameter.
 PNU = 3B3hex, Subindex = 1hex → Specify PNU947 (= 3B3hex) and Index 1.
 PVA = 0000 0000hex → No entry required for PVA.

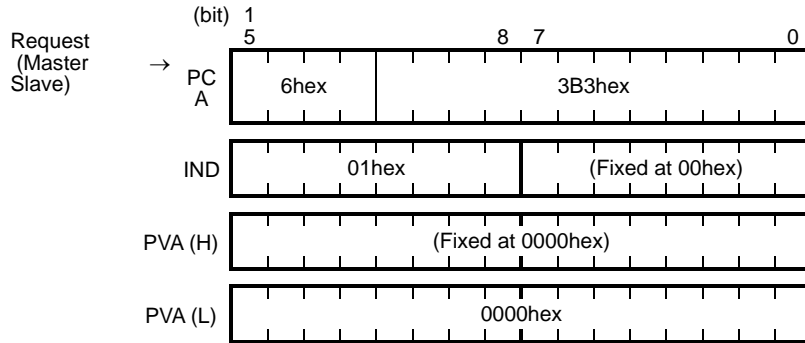

- 2) Response example sent from the card (normal response from the slave node)
 RC = 4hex → Requested array parameter value is normally returned.
 PNU = 3B3(hex), Subindex = 01 hex → Accessed parameter is PNU947 (=3B3hex), Index 1.
 PVA = 0000 7511hex → Parameter value read is 7511hex, PROFIBUS communications error *er5*

📖 For the values of PNU947, refer to Chapter 11 "ALARM CODE LIST."

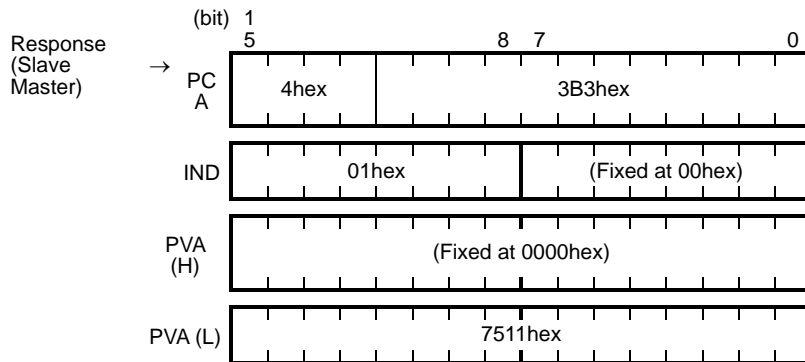

- 3) Response example for the read data error (Accessed parameter cannot be read as an array parameter.)
 RC = 7hex → Parameter transmission error.
 PNU = 3B3hex, Subindex = 01hex → Accessed parameter is function code y100.
 PVA = 0000 0003hex → Error code 3 (Invalid Subindex specified)

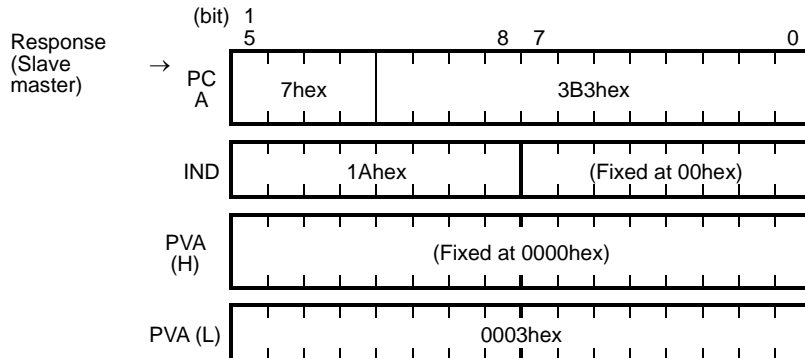

(4) PROFIdrive specific parameters

Table 17 lists PROFIdrive specific parameters supported by this card. PNUs with descriptions in the index column are array parameters.

Table 17 List of PROFIdrive Specific Parameters

PNU	Index	Description	Range	R/W	Remarks
915	1 to 4	Function code assignment to PCD1 to PCD4 (Request) (Write function code data)	0000 to FFFFhex	R/W	Same as o40 to o43.
916	1 to 4	Function code assignment to PCD1 to PCD4 (Response) (Read/monitor function code data)	0000 to FFFFhex	R/W	Same as o48 to o51.
918	None	Node (station) address	0 to 125	R	
927	None	Access permission to PCV area 0: Inhibit to write 1: Permit to write	0 or 1	R/W	Once writing is inhibited, this PNU only is writable.
947	1	Malfunction history (Latest)	Depends on errors listed in Table 19.	R	Indicated by PROFIdrive malfunction codes whose data formats differ from the ones of inverter's alarm codes defined by inverter's function codes M16 to M19.*
	9	Malfunction history (Last)			
	17	Malfunction history (2nd last)			
	25	Malfunction history (3rd last)			
	Other than the above	Fixed to 0.			
963	None	Current baud rate 0: Not specified 1: 9.6 Kbps 2: 19.2 Kbps 3: 45.45 Kbps 4: 93.75 Kbps 5: 187.5 Kbps 6: 500 Kbps 7: 1.5 Mbps 8: 3 Mbps 9: 6 Mbps 10: 12 Mbps	0 to 10	R	
965	None	PROFIdrive version	Fixed to 2	R	Shows PROFIdrive V2.
967	None	Last CTW sent	0000 to FFFFhex	R	
968	None	Latest STW	0000 to FFFFhex	R	
970	None	Initialize the inverter (Changing from "1" to "0" triggers the initialization.)	0 or 1	R/W	Functionally equivalent to H03.

* For the relationship between the malfunction codes and alarm codes, refer to Chapter 11 "ALARM CODE LIST."

Chapter 10 INVERTER REACTION TO PROFIBUS COMMUNICATIONS ERRORS

The PROFIBUS DP master node can be equipped with a watchdog timer (WDT) that detects communications timeout for monitoring the communications status. If this card receives no response within the WDT timeout length, it interprets the timeout state as an occurrence of a communications error.

Inverter's function codes o27 and o28 specify the inverter reaction to be taken after such an error occurrence. (See Table 18.)

 For the setup of WDT in the PROFIBUS DP master equipment, see the user's manual of your master equipment.

 For the error indication on the card at the time of a communications error, see Chapter 3, Section 3.1 "Status Indicator LEDs."

 **Note** If a communications error occurs immediately after the inverter is powered on, no *er5* trip will be issued. The *er5* trip is issued when a communications error is detected after once the card received data normally.

Table 18 Inverter Reaction to PROFIBUS DP Communications Errors Using Function Codes o27 and o28 taka

o27 data	o28 data	Inverter reaction to PROFIBUS DP communications errors	Remarks
0, 4 to 9	Invalid	Immediately coast to a stop and trip with <i>er5</i> .	
1	0.0 s to 60.0 s	After the time specified by o28, coast to a stop and trip with <i>er5</i> .	
2	0.0 s to 60.0 s	If the inverter receives any data within the time specified by o28, ignore the communications error. After the timeout, coast to a stop and trip with <i>er5</i> .	
3, 13 to 15	Invalid	Keep the current operation, ignoring the communications error. (No <i>er5</i> trip)	During the communications error state, the LED displays the abnormal state. (PWR: Flashes in red, OFFL: Lights in red.)
10	Invalid	Immediately decelerate to a stop. Issue <i>er5</i> after stopping.	The inverter's function code F08 specifies the deceleration time.
11	0.0 s to 60.0 s	After the time specified by o28, decelerate to a stop. Issue <i>er5</i> after stopping.	Same as above.
12	0.0 s to 60.0 s	If the inverter receives any data within the time specified by o28, ignore the communications error. After the timeout, decelerate to a stop and trip with <i>er5</i> .	Same as above.

Chapter 11 ALARM CODE LIST

In PROFIBUS DP communication, alarms that occur in the inverter can be monitored with malfunction codes in the PROFdrive specific parameter PNU974 or with alarm codes in the inverter's function codes M17 through M19.

- (1) PROFdrive specific parameter PNU947
- (2) Inverter's function codes M16, M17, M18 and M19 (latest, last, 2nd last, and 3rd last alarm codes).

Table 19 lists their malfunction codes and alarm codes.

 The data format used for PNU947 is different from that for the inverter's function codes M16 to M19.

 For details about PNU947, refer to Chapter 9, Section 9.3 (4) "PROFdrive Specific Parameters."

Table 19 Malfunction Codes and Alarm Codes

Malfunction codes in PNU947	Alarm codes in M16 to M19	Description		Malfunction codes in PNU947	Alarm codes in M16 to M19	Description	
0000	0	---	---	4210	22	Braking resistor overheated	<i>dbh</i>
2301	1	Overcurrent (during acceleration)	<i>oc1</i>	2211	23	Motor overload	<i>ol1</i>
2302	2	Overcurrent (during deceleration)	<i>oc2</i>	2200	25	Inverter overload	<i>olu</i>
2303	3	Overcurrent (during running at constant speed)	<i>oc3</i>	5500	31	Memory error	<i>er1</i>
2330	5	Grounding fault	<i>ef</i>	7520	32	Keypad communication error	<i>er2</i>
3211	6	Overvoltage (during acceleration)	<i>ou1</i>	5220	33	CPU error	<i>er3</i>
3212	7	Overvoltage (during deceleration)	<i>ou2</i>	7510	34	Interface card communications error	<i>er4</i>
3213	8	Overvoltage (during running at constant speed or being stopped)	<i>ou3</i>	7511	35	Field bus communications error	<i>er5</i>
3220	10	Undervoltage	<i>lu</i>	F004	36	Operation protection	<i>er6</i>
3130	11	Input phase loss	<i>lln</i>	7200	37	Tuning error	<i>er7</i>
5450	14	Blown fuse	<i>fus</i>	B100	38	RS-485 communications error	<i>er8</i>
5440	16	Charging circuit fault	<i>pbf</i>	3300	46	Output phase loss	<i>opl</i>
4310	17	Overheating of the heat sink	<i>oh1</i>	6300	51	Data save error due to undervoltage	<i>erf</i>
9000	18	External alarm	<i>oh2</i>	7520	53	RS-485 communications error (option)	<i>erp</i>
4110	19	Inverter overheat	<i>oh3</i>	5220	54	LSI error	<i>erh</i>
4310	20	Motor protection (PTC thermistor)	<i>oh4</i>				

Chapter 12 TROUBLESHOOTING

If any problem occurs with the card, follow the procedures below.

No.	Problems	Possible causes
1	None of the LEDs on the card would light.	<ul style="list-style-type: none"> The inverter is not powered ON. The card is not properly installed. The card is defective.
2	The inverter cannot escape from the <i>er4</i> alarm trip. The PWR LED lights in red.	<ul style="list-style-type: none"> The card is not properly installed. The card is defective.
3	PROFIBUS communication is not possible. The PWR LED blinks in red and the OFFL LED lights in red.	<ul style="list-style-type: none"> The valid GSD file has not been registered to the PROFIBUS master node. The node address of the card is not identical with the one registered to the PROFIBUS master node. Node addresses duplicated. The cabling does not meet PROFIBUS DP requirements. The cable used is not a PROFIBUS DP dedicated one. Terminating resistors are not inserted at both ends of the PROFIBUS DP communications network.
4	PROFIBUS communications is not possible. The ERR LED blinks in red.	<ul style="list-style-type: none"> The inverter's function code o30 has not been configured. The data for o30 should be identical with the PPO type registered for the PROFIBUS master node. The inverter power has not been turned OFF and ON again after setting of the function code o30.
5	The inverter cannot escape from the <i>er4</i> alarm trip. or The inverter trips with <i>er5</i> soon after starting PROFIBUS communication. The PWR LED blinks in red and the OFFL LED lights in red.	<ul style="list-style-type: none"> The timeout length specified in the watchdog timer in the PROFIBUS master node equipment is too short. The inverter's function code o31 is set to "126" or greater. The cable used is not a PROFIBUS DP dedicated one.. The card is not grounded.
6	Run or frequency command by CTW or MRV is not validated.	<ul style="list-style-type: none"> The inverter's function code y98 is not set to "3." Run or frequency command specified by the function code has priority. (e.g. y99 specifies, terminal command LE or LOC) Check the PPO type format selected.
7	PCD1 to PCD4 assignments for PPO type 2 or type 4 are not validated properly.	<ul style="list-style-type: none"> The inverter's function code o30 is not set. Or the inverter power has not been turned OFF and ON again after setting of the function code o30. The inverter power has not been turned OFF and ON again after setting of function codes o40 to o43 and o48 to o51.
8	Setting the node address to "0" does not take effect.	<ul style="list-style-type: none"> The inverter power has not been turned OFF and ON again after changing of the node address. The inverter's function code o30 is set to nonzero.
9	Frequency command validated, but the actual motor speed is different from the command.	<ul style="list-style-type: none"> Refer to the FRENIC-Eco Instruction Manual (INR-SI47-1225-E), Chapter 6, Section 6.2.1 "Motor is running abnormally."

Chapter 13 SPECIFICATIONS

13.1 General Specifications

For the items not covered in this section, the specifications of the inverter apply.

Item	Specifications
Model	OPC-F1-PDP
Operating ambient temperature range	-10 to +50°C(14 to 122 °F) (Temperature around the inverter)
Operating ambient humidity range	5 to 95% RH (Condensation not allowed)
External dimensions	94 x 63 mm(3.7 x 2.48 in)
Applicable inverter	FRENIC-Eco series (with all software versions)

13.2 Communications Specifications

For the items not covered in this section, the specifications of the PROFIBUS DP apply.

Item	Specifications	Remarks	
Transmission section	Lines	RS-485 (insulated cable)	
	Cable length	See the table below.	
	Transmission speed	9.6 Kbps to 12 Mbps (auto configuration)	To be specified in the master node
	Protocol	PROFIBUS DP (DP-V0)	IEC 61158 and 61784
Connector	Pluggable, six-pin terminal block	MC1.5/6-STF-3.81 manufactured by Phoenix Contact Inc.	
Control section	Controller	SPC3 (Siemens)	
	Comm. buffer	1472 bytes (SPC3 built-in memory)	
Addressing	By on-board node address switches (rotary switches) (0 to 99) or By inverter's function code o31 (data = 0 to 125)	Setting both node address switches SW1 and SW2 to "0" enables the o31 setting.	
Diagnostics	Detection of disconnection	Indicated by the OFFL LED	
	Detection of the illegal configuration	Indicated by the ERR LED	

Maximum cable length per segment for PROFIBUS DP specific cable

Transmission speed	Maximum cable length (m) per segment
9.6 Kbps	1200
19.2 Kbps	1200
93.75 Kbps	1000
187.5 Kbps	1000
500 Kbps	400
1.5 Mbps	200
3 Mbps	100
6 Mbps	100
12 Mbps	100

PROFIBUS DP Interface Card "OPC-F1-PDP"

Instruction Manual

First Edition, June 2006

Fuji Electric FA Components & Systems Co., Ltd.

The purpose of this manual is to provide accurate information in the handling, setting up and operating of PROFIBUS DP Interface Card "OPC-F1-PDP" for the FRENIC-Eco series of inverters. Please feel free to send your comments regarding any errors or omissions you may have found, or any suggestions you may have for generally improving the manual.

In no event will Fuji Electric FA Components & Systems Co., Ltd. be liable for any direct or indirect damages resulting from the application of the information in this manual.

MEMO

Fuji Electric Systems Co., Ltd.
Fuji Electric Corp. of America

47520 Westinghouse Drive Fremont, CA 94539, U.S.A.
Tel.+1-510-440-1060 Fax.+1-510-440-1063
Toll-free support 1-888-900-FUJI(3854)
INR-SI47-1144-EU Rev 052010

<http://www.fujielectric.com/fecoa/>

Information subject to change without notice.
