

### Correct use

Precision single limit switches series N1A are interlocking devices without guard locking (type 1). The actuator is uncoded (e.g. dog). In combination with a movable guard and the machine control, this safety component prevents dangerous machine functions from occurring while the guard is open. A stop command is triggered if the guard is opened during the dangerous machine function.

For general applications, snap-action switching elements ES502E are used. For use as safety switches, only the switching elements ES508E, ES514 and ES588 with positively driven contacts are allowed.

This means:

- ▶ Starting commands that cause a dangerous machine function must become active only when the guard is closed.
- ▶ Opening the guard triggers a stop command.
- ▶ Closing a guard must not cause automatic starting of a dangerous machine function. A separate start command must be issued. For exceptions, refer to EN ISO 12100 or relevant C-standards.

Devices from this series can be used as safe position encoders.

Before the device is used, a risk assessment must be performed on the machine, e.g. in accordance with the following standards:

- ▶ EN ISO 13849-1
- ▶ EN ISO 12100
- ▶ IEC 62061

Correct use includes observing the relevant requirements for installation and operation, particularly based on the following standards:

- ▶ EN ISO 13849-1
- ▶ EN ISO 14119
- ▶ EN 60204-1

### Important!

- ▶ The user is responsible for the proper integration of the device into a safe overall system. For this purpose, the overall system must be validated, e.g. in accordance with EN ISO 13849-2.
- ▶ If the simplified method according to section 6.3 of EN ISO 13849-1:2015 is used for determining the Performance Level (PL), the PL might be reduced if several devices are connected in series.
- ▶ Logical series connection of safe contacts is possible up to PL d in certain circumstances. More information about this is available in ISO TR 24119.
- ▶ If a product data sheet is included with the product, the information on the data sheet applies in case of discrepancies with the operating instructions.

### Safety precautions

#### ⚠ WARNING

Danger to life due to improper installation or due to bypassing (tampering). Safety components perform a personnel protection function.

- ▶ Safety components must not be bypassed, turned away, removed or otherwise rendered ineffective. On this topic pay attention in particular to the measures for reducing the possibility of bypassing according to EN ISO 14119:2013, section 7.
- ▶ Mounting, electrical connection and setup only by authorized personnel possessing special knowledge about handling safety components.

### Function

Precision single limit switches are used for positioning and control applications in mechanical and systems engineering.

The switching elements are actuated by means of plungers. Different plunger types and trip dogs are used depending on the application (operating point accuracy and approach speed) (see Fig. 4).

In general applications the plunger is actuated by trip dogs according to DIN 69639 that are mounted with an interference fit in trip rails in accordance with DIN 69638.

The switching contacts are actuated when the actuating element is moved from the free position to the end position. The safety contacts (⊖) are positively opened in this process (see Fig. 2).

### Switching states

The detailed switching states for your switch can be found in Fig. 2. All available switching elements are described there.

#### Actuating element in free position

The safety contacts (⊖) are closed.

#### Actuating element in end position

The safety contacts (⊖) are open.

### Mounting

#### NOTICE

Device damage due to improper mounting and unsuitable ambient conditions

- ▶ Safety switches and actuators must not be used as an end stop.
- ▶ Observe EN ISO 14119:2013, sections 5.2 and 5.3, for information about mounting the safety switch and the actuator.
- ▶ Observe EN ISO 14119:2013, section 7, for information about reducing the possibilities for bypassing an interlocking device.
- ▶ It is imperative that dimension (12.05) (distance from switch reference surface to trip dogs, see Fig. 6) is maintained in safety circuits to ensure safe contact opening.
- ▶ Protect the switch against damage.
- ▶ The specified IP degree of protection is applicable only if the housing screws, cable entries and plug connectors are properly tightened. Observe the tightening torques.

### Protection against environmental effects

Safety venting valves (see Fig. 7) are used to compensate for the pumping action of the plungers. They must not be sealed with paint.

- ▶ Mask plunger, plunger guide, safety venting valves and rating plate during painting work!

### Changing the actuating direction

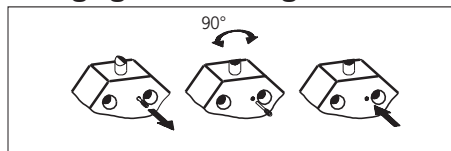

Fig. 1: Changing the actuating direction

1. Unscrew the locking screw.
2. Set the required direction.
3. Screw in the locking screw again.

### Electrical connection

#### ⚠ WARNING

Loss of the safety function due to incorrect connection.

- ▶ Use only safe contacts (⊖) for safety functions.
- ▶ Strip the insulation from the ends of the individual wires over a length of  $6^{+1}$  mm to ensure a safe contact.

When switches with indicators that can be retrofitted are used, the voltage range printed on the indicator housing must be observed (for connection, see Fig. 2).

#### Use of the safety switch as an interlocking device for personnel protection

At least one contact (⊖) must be used. This signals the position of the guard (for terminal assignment, see Fig. 2).

#### The following information applies to devices with plug connector:

- ▶ Check that the plug connector is sealed.

#### The following information applies to devices with cable entry:

1. Use a suitable tool to open the desired insertion opening.
2. Fit the cable gland with the appropriate degree of protection.
3. Connect and tighten the terminals (for terminal assignment, see Fig. 2; for tightening torque values, see technical data).
4. Check that the cable entry is sealed.
5. Close the switch cover and screw in place (see technical data for tightening torque).

### Function test

#### ⚠ WARNING

Fatal injury due to faults during the function test.

- ▶ Before carrying out the function test, make sure that there are no persons in the danger zone.
- ▶ Observe the valid accident prevention regulations.

Check the device for correct function after installation and after every fault.

Proceed as follows:

#### Mechanical function test

The actuating element must move easily. Close the guard several times to check the function.

#### Electrical function test

1. Switch on operating voltage.
  2. Close all guards.
    - The machine must not start automatically.
  3. Start the machine function.
  4. Open the guard.
    - The machine must switch off and it must not be possible to start it as long as the guard is open.
- Repeat steps 2 - 4 for each guard.

## Inspection and service

### ⚠ WARNING

Danger of severe injuries due to the loss of the safety function.

- ▶ In safety circuits, the entire switch must be replaced in case of damage or wear. Replacement of individual parts or assemblies is not permitted.
- ▶ Check the device for proper function at regular intervals and after every fault. For information about possible time intervals, refer to EN ISO 14119:2013, section 8.2.

Inspection of the following is necessary to ensure trouble-free long-term operation:

- ▶ correct switching function
- ▶ secure mounting of all components
- ▶ precise adjustment of trip dogs in relation to single limit switch
- ▶ damage, heavy contamination, dirt and wear
- ▶ sealing of cable entry
- ▶ loose cable connections or plug connectors.

**Info:** The year of manufacture can be seen in the bottom, right corner of the type label.

## Exclusion of liability and warranty

In case of failure to comply with the conditions for correct use stated above, or if the safety regulations are not followed, or if any servicing is not performed as required, liability will be excluded and the warranty void.

## Notes about

The following information applies to devices with cable entry:

For use and applications as per the requirements of , copper wire is to be used.

The following information applies to devices with plug connector:

This device is intended to be used and applied with a Class 2 power source in accordance with UL1310. Connecting cables for safety switches installed at the place of use must be separated from all moving and permanently installed cables and un-insulated active elements of other parts of the system that operate at a voltage of over 150 V. A constant clearance of 50.8 mm must be maintained. This does not apply if the moving cables are equipped with suitable insulation materials that possess an identical or higher dielectric strength compared to the other relevant parts of the system.

## EU declaration of conformity

The declaration of conformity is part of the operating instructions, and it is included as a separate sheet with the device.

The original EU declaration of conformity can also be found at: [www.euchner.com](http://www.euchner.com)

## Service

If servicing is required, please contact:

EUCHNER GmbH + Co. KG  
Kohlhammerstraße 16  
70771 Leinfelden-Echterdingen  
Germany

**Service telephone:**  
+49 711 7597-500

**E-mail:**  
[support@euchner.de](mailto:support@euchner.de)

**Internet:**  
[www.euchner.com](http://www.euchner.com)

## Technical data

Parameter	Value	
Housing material	Die-cast aluminum, anodized	
Plunger material	Stainless steel	
Degree of protection	IP67	
Mech. operating cycles		
- Switch		30x10 <sup>6</sup>
	For N1A.2588	1x10 <sup>6</sup>
- Switching element	ES502E/ES508E	30x10 <sup>6</sup>
	ES514	1x10 <sup>6</sup>
	ES588	10x10 <sup>6</sup>
Switching frequency	ES502E	300 min <sup>-1</sup>
	ES508E/ES514	50 min <sup>-1</sup>
	ES588	20 min <sup>-1</sup>
Ambient temperature	ES502E	-5...+80°C
	ES508E/ES514	-25...+80°C
	ES588	-25...+70°C
Installation orientation	Any	
Approach speed, max.		
Plunger	Chisel D	40 m/min
	Roller R (slide bearing)	80 m/min
	Roller B (ball bearing)	120 m/min
	Dome W/ball K	10 m/min
	Extended roller	20 m/min
Approach speed, min.	0.01 m/min	
Actuating force	ES502E	≥ 20 N
with switching element	ES508E	≥ 15 N
	ES514	≥ 30 N
	2 x ES588	≥ 20 N
Switching element		
ES502E	1 NO + 1 NC contact	
ES508E	1 pos. driven contact	
ES514	1 NO + 1 pos. driven contact	
ES588	1 pos. driven contact	
Switching principle		
ES502E/ES514	Snap-action switching contact	
ES508E/ES588	Slow-action switching contact	
Hysteresis	ES502E	0.8 mm
	ES514	0.6 mm
Contact material		
ES502E/ES508E/ES514	Silver alloy, gold flashed	
ES588	Fine silver	
Connection		
N1A...M	Screw terminals	
N1A...SVM5...	Plug connector M12	
Tightening torque of screw terminal		
ES588 (slot head screw)	0.3 Nm	
ES502E/ES508E (cross-head screw)	0.6 Nm	
ES514 (cross-head screw)	0.9 Nm	
Rated insulation voltage		
with cable entry	U <sub>i</sub> = 250 V	
with plug connector		
- 4-pin	U <sub>i</sub> = 250 V	
- 5-pin	U <sub>i</sub> = 50 V	
Rated impulse withstand voltage with cable entry		
ES508E/ES514	U <sub>imp</sub> = 4 kV	
ES502E/ES588	U <sub>imp</sub> = 2.5 kV	
with plug connector		
- 4-pin	U <sub>imp</sub> = 2 kV	
- 5-pin	U <sub>imp</sub> = 1.5 kV	
Utilization category of switching element acc. to IEC 60947-5-1		
ES502E	AC-12	250 V 8 A
ES502E/ES508E	AC-15	230 V 6 A
	DC-13	24 V 6 A
ES514	AC-15	230 V 2.5 A
	DC-13	24 V 6 A
ES588	AC-15	230 V 4 A
	DC-13	24 V 3 A
Switching current, min.,		
at DC 24 V	ES514	5 mA
	ES508E	10 mA
at DC 12 V	ES502E	10 mA
at DC 5 V	ES588	1 mA
Convent. thermal current I <sub>th</sub>		
ES502E	8 A	
ES508E/ES514/ES588	10 A	

Short circuit protection acc. to IEC 60269-1 (control circuit fuse)

ES502E	8 A gG	
ES508E/ES588	10 A gG	
ES514	6 A gG	
Conditional short-circuit current	100 A	
Indicator LED	LE060	AC/DC 12 - 60 V
(only with ES502E/ES508E)	LE110	AC 110 V ± 15%
	LE220	AC 220 V ± 15%

Reliability values acc. to EN ISO 13849-1 for switching elements	ES508E	ES514
	ES588	ES514
B10D	2 x 10 <sup>7</sup>	2 x 10 <sup>6</sup>

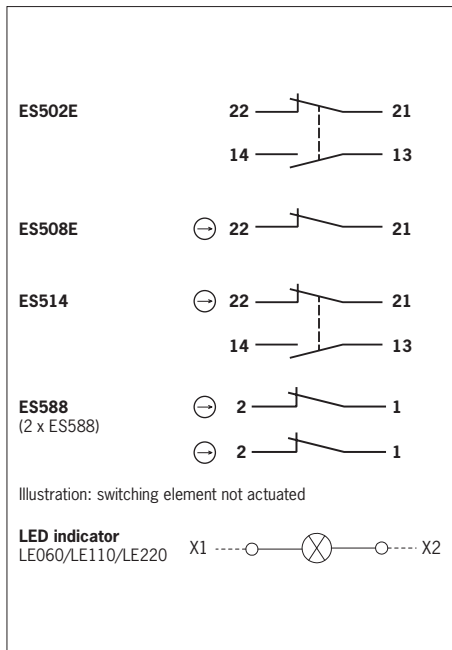

Fig. 2: Switching elements and terminal assignment

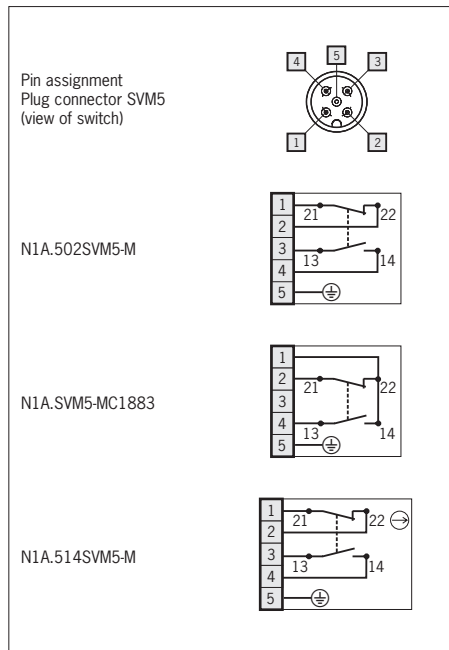

Fig. 3: Connector assignment of plug connector M12

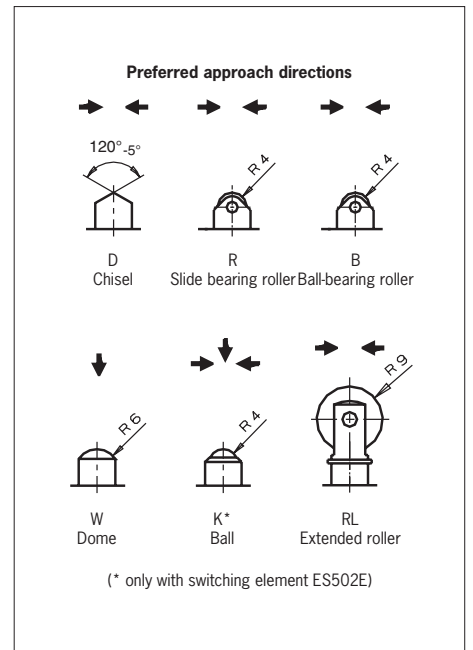

Fig. 4: Plungers and approach directions

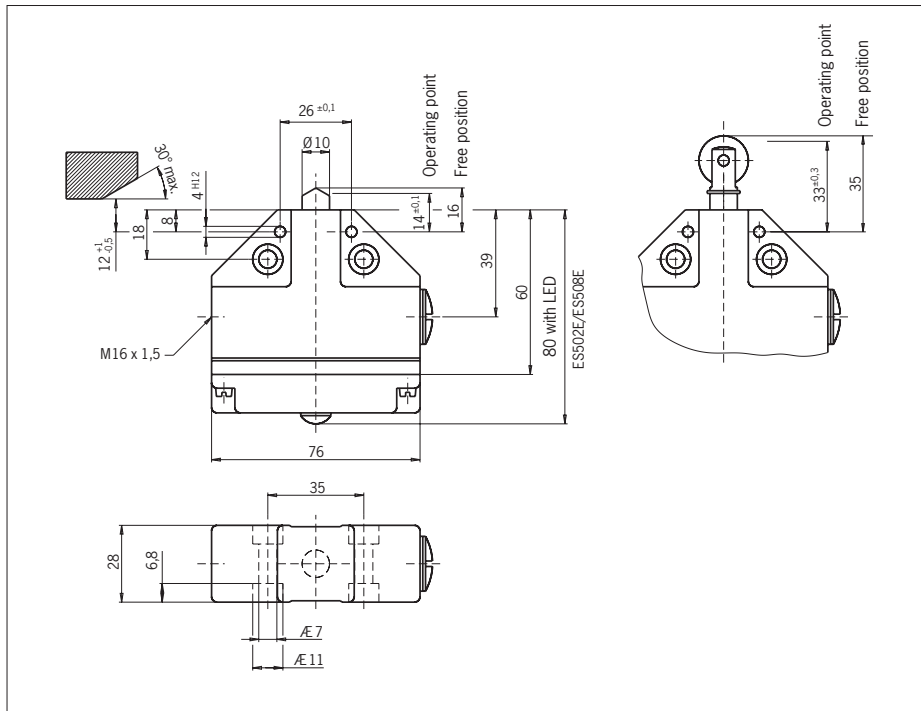

Fig. 5: Dimension drawing for N1A.502/508/514

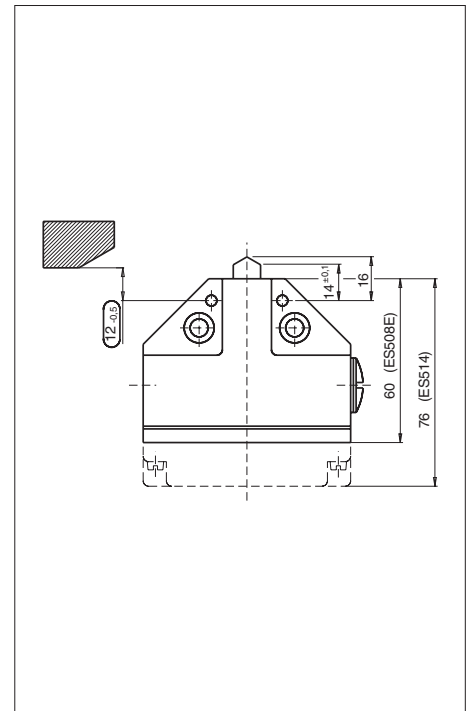

Fig. 6: Dimension drawing for N1A.508/...514

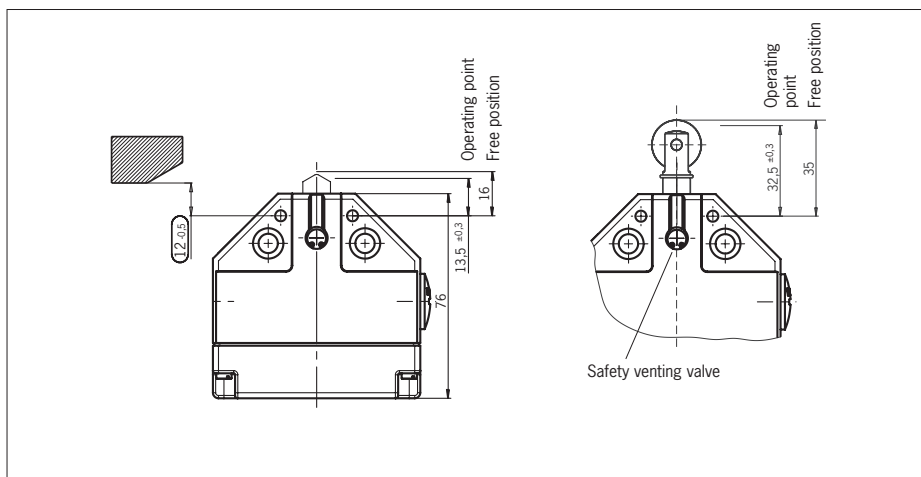

Fig. 7: Dimension drawing for N1A.2588 (2 x ES588)

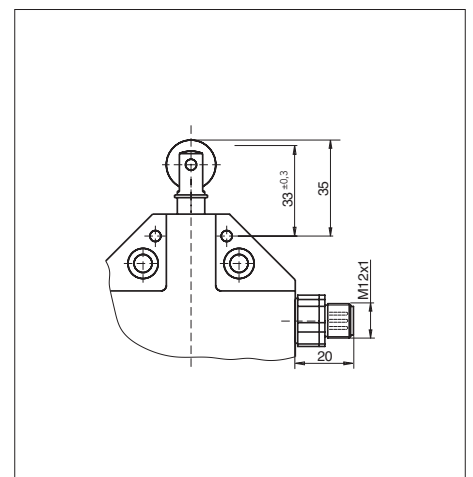

Fig. 8: Dimension drawing for N1A... with plug connector M12