

65E CONTROL SERIES

DART

CONTROLS

Instruction Manual

For DC Input Variable Speed Controls



**5000 W. 106th Street
Zionsville, Indiana 46077**

**Phone (317) 873-5211
Fax (317) 873-1105
www.dartcontrols.com**

TABLE OF CONTENTS

WARRANTY	1
CONTROL DIMENSIONS	1
STANDARD FEATURES	2
MOUNTING DIMENSIONS	2-3
INSTALLATION (DIAGRAM)	3
HOOK-UP DIAGRAMS	4-5
65E10/20 HOOK-UP DIAGRAM	4
65E10/20 REVERSING HOOK-UP DIAGRAM	5
65E10/20E HOOK-UP DIAGRAM	5
FUSING	6
INHIBITING THE CONTROL	6
TRIMPOT AND JUMPER SETUP	6
OPTIONS	7-8
-UVL	7
-LED	8
-FOLLOWER SIGNALS	8
CURRENT LIMIT FUNCTIONS	8
IN CASE OF DIFFICULTY	9
MODEL SELECTION	9
SPECIFICATIONS	9

WARRANTY

Dart Controls, Inc. (DCI) warrants its products to be free from defects in material and workmanship. The exclusive remedy for this warranty is DCI factory replacement of any part or parts of such product which shall within 12 months after delivery to the purchaser be returned to DCI factory with all transportation charges prepaid and which DCI determines to its satisfaction to be defective. This warranty shall not extend to defects in assembly by other than DCI or to any article which has been repaired or altered by other than DCI or to any article which DCI determines has been subjected to improper use. DCI assumes no responsibility for the design characteristics of any unit or its operation in any circuit or assembly. This warranty is in lieu of all other warranties, express or implied; all other liabilities or obligations on the part of DCI, including consequential damages, are hereby expressly excluded.

NOTE: Carefully check the control for shipping damage. Report any damage to the carrier immediately. Do not attempt to operate the drive if visible damage is evident to either the circuit or to the electronic components.

All information contained in this manual is intended to be correct, however information and data in this manual are subject to change without notice. DCI makes no warranty of any kind with regard to this information or data. Further, DCI is not responsible for any omissions or errors or consequential damage caused by the user of the product. DCI reserves the right to make manufacturing changes which may not be included in this manual.

WARNING

Improper installation or operation of this control may cause injury to personnel or control failure. The control must be installed in accordance with local, state, and national safety codes. Make certain that the power supply is disconnected before attempting to service or remove any components!!! If the power disconnect point is out of sight, lock it in disconnected position and tag to prevent unexpected application of power. Only a qualified electrician or service personnel should perform any electrical troubleshooting or maintenance. At no time should circuit continuity be checked by shorting terminals with a screwdriver or other metal device.

CONTROL DIMENSIONS

MODEL	WIDTH	LENGTH	HEIGHT	WEIGHT	TYPE
	inches (centimeters)			oz. (gms.)	
65E10C	3.620 (9.19)	4.25 (10.76)	1.30 (3.30)	8.0 (227)	CHASSIS
65E20C	3.620 (9.19)	4.25 (10.76)	2.026 (5.15)	8.0 (227)	CHASSIS
65E10E, 65E20E	5.530 (14.00)	7.30 (18.50)	4.782 (12.1)	40.0 (1134)	ENCLOSED

STANDARD FEATURES

- Provides smooth variable speed capability for mobile, solar-powered and other DC powered equipment
- Maintains variable speed control as batteries discharge
- Adjustable maximum speed, minimum speed, current limit, IR compensation, and motor acceleration
- Inhibit terminal permits optional start-stop without breaking battery lines
- Speed potentiometer, knob, and dial plate included
- Increases range or running time of battery operated equipment through high efficiency
- Enclosed model is NEMA 4X rated
- Wide 12-48VDC source power input; up to 20A continuous output current
- High (18KHz) switching frequency for quiet operation
- Improved efficiency (lower voltage drop across control)
- Current Limit Lock Out or High Limit - user selectable
- Solid state Current Limit Output
- Wide temperature range for outdoor applications (-30°C (-22°F) to 60°C (140°F) for Chassis model; -15°C (5°F) to 45°C (113°F) for Enclosed model)
- 0-10VDC Input Follower Signal capability
- Optional source power Under Voltage Lockout (UVL) Option - protects battery source from deep cycle discharge
- Optional remote Power and Current Limit LED driver output for chassis models only
- Power and Current Limit LED's are located in the cover on Enclosed models only

MOUNTING DIMENSIONS

65E10C/20C MOUNTING

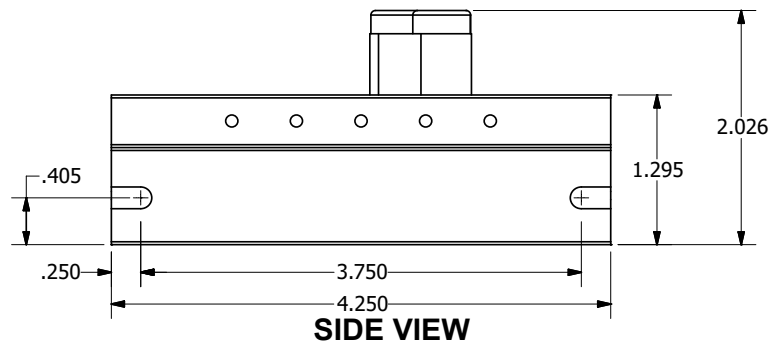
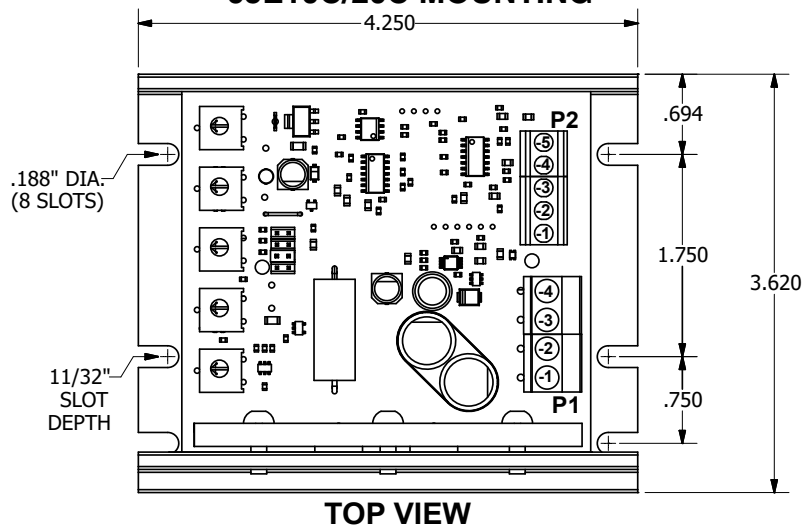

65E10E/20E MOUNTING

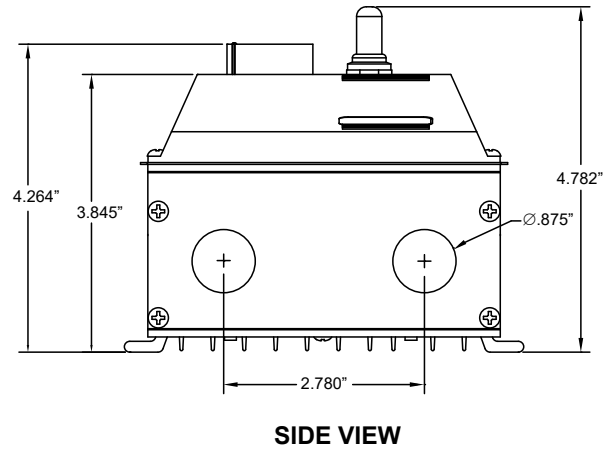
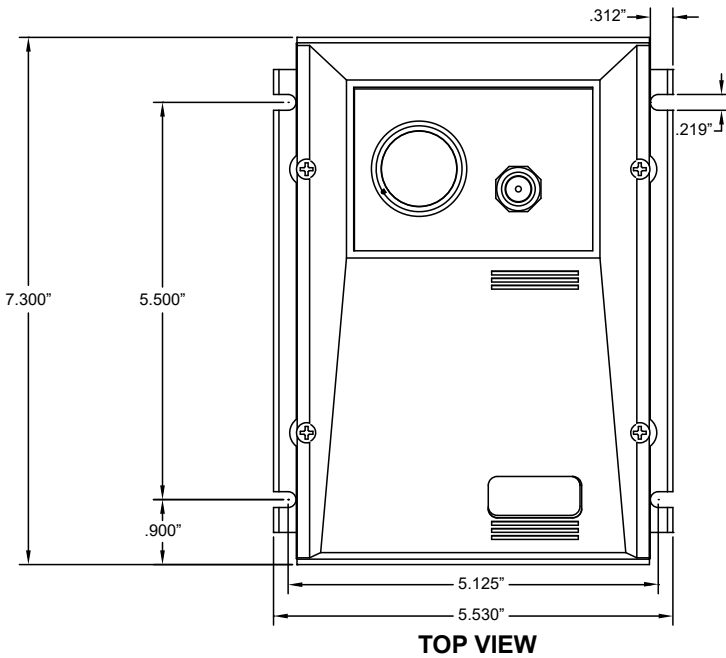

Caution: Do not mount controller where ambient temperature is outside the range of -30°C (-22°F) to 60°C (140°F) for Chassis model; -15°C (5°F) to 45°C (113°F) for Enclosed model.

INSTALLATION (DIAGRAM)

Before attempting to wire the control, make sure all power is disconnected. Recheck code designation to assure proper voltage is present for the control. Caution should be used in selecting proper size of hook-up wire for current and voltage drop.

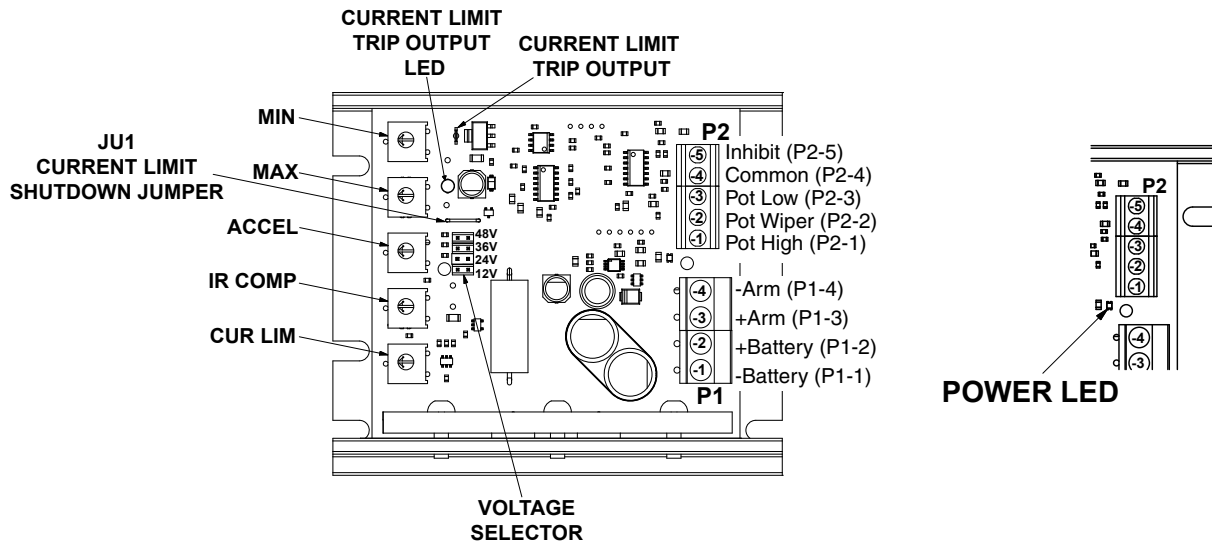

The suggested female wire connector for the .110" male spade terminal is a Molex Inc. part number 1090030024.

HOOK-UP DIAGRAMS

WARNING:

DO NOT REVERSE POSITIVE AND NEGATIVE BATTERY LEADS. THIS WILL DAMAGE THE CONTROL. TO CHANGE MOTOR DIRECTION, INTERCHANGE THE POSITIVE AND NEGATIVE ARMATURE LEADS.

Refer to the wiring diagrams below for proper connection of **DC Voltage**, **Armature**, and **Speedpot wiring** to the control.

CAUTION !! TURN POWER OFF WHILE MAKING CONNECTIONS.

65E10/20 HOOK-UP DIAGRAM

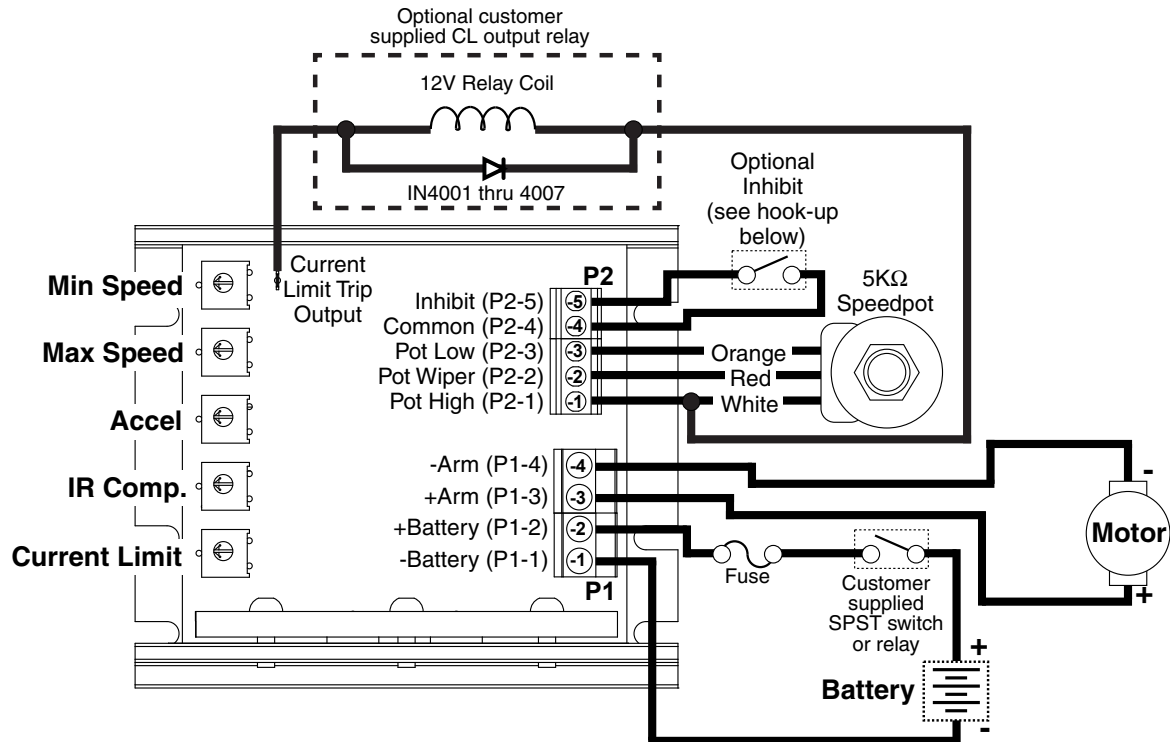

65E10/20 REVERSING HOOK-UP DIAGRAM

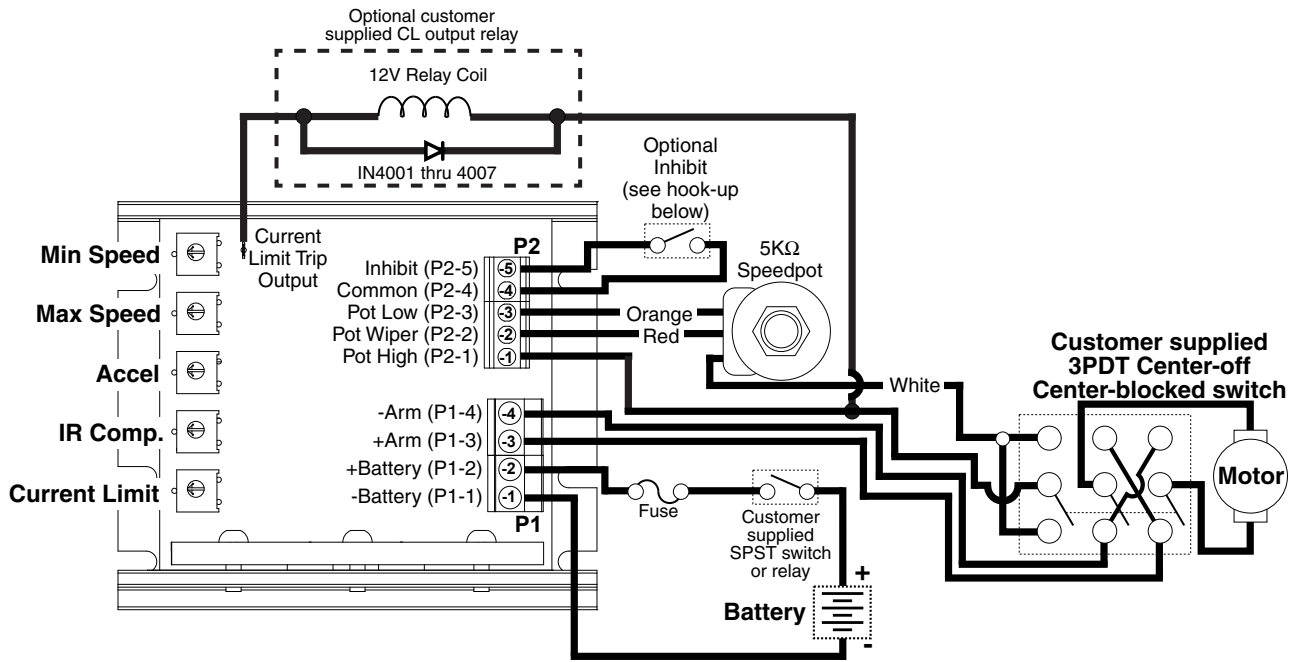

Caution: When reversing a spinning motor, care must be taken that the resulting current through the armature of the motor does not exceed the overload ratings of the control, or the demagnetize rating of the motor being reversed when using a permanent magnet DC motor.

65E10/20E HOOK-UP DIAGRAM

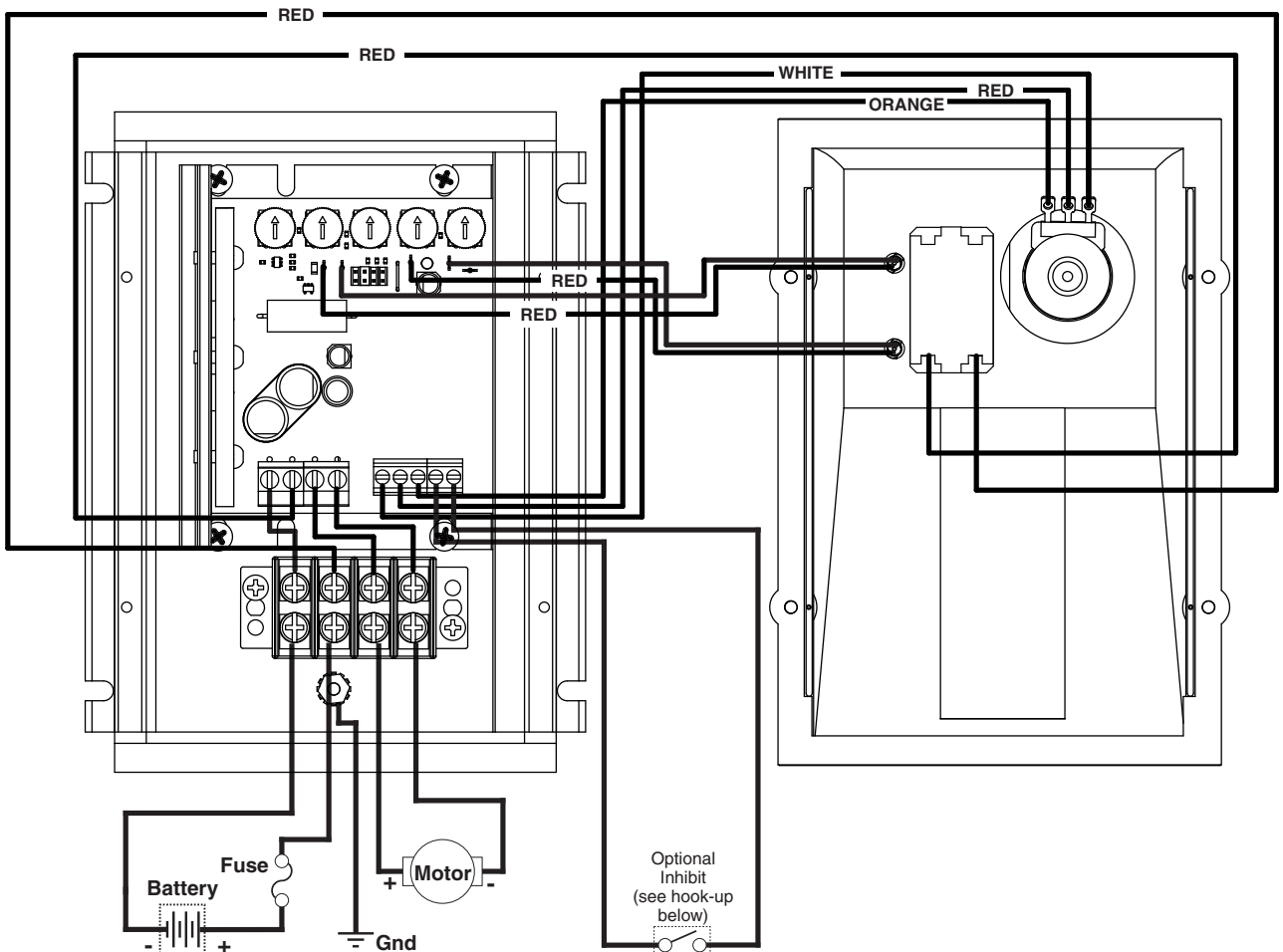

FUSING

Externally fuse the +Battery (P1-2) input line with Littlefuse CCMR series or Bussman LP-CC series or equivalent fuses designed for use with motors and motor control systems; rated for the lesser of:
 1) 200% of the continuous current rating of the drive, or 2) 150% of the motor full-load current.

INHIBITING THE CONTROL

Using inhibit input - provides fast start-stop by bypassing accel circuit

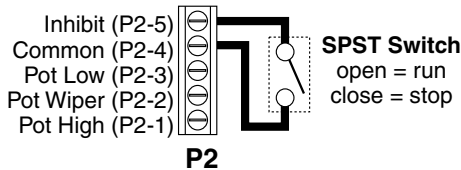

Inhibit via speedpot - provides starting and stopping through accel parameters

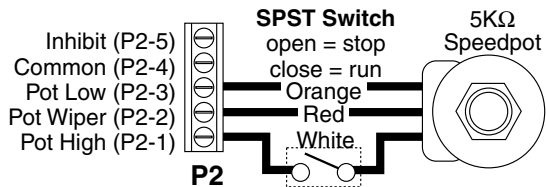

Note: Always use a shielded cable when connecting to the inhibit terminal. The shield of the cable should connect to the Common terminal of the control.

TRIMPOT AND JUMPER SETUP (See Options Section for UVL Adjustments)

Before the power is applied, the speed potentiometer and trimpots should be preset as follows:

CONTROL PRESET

1. Control Speed pot - Full CCW
2. Min - Full CCW, Max - 50%, Accel - Full CCW, C.L. - Full CW, IR Comp - Full CCW
3. Voltage Selector jumper - Set the jumper to the correct supply voltage being used.

DC power can now be applied to the system and the control adjusted as directed below:

TRIMPOT ADJUSTMENT

- MIN** - Increase the **MIN** trimpot in a clockwise direction until just before reaching an output voltage (deadband) or until the desired minimum speed is reached.
- MAX** - Turn the Speedpot fully clockwise and adjust the **MAX** trimpot until the desired maximum speed is reached.
- ACCEL** - Adjust the **ACCEL** trimpot to achieve the desired soft start time. CW rotation will increase accel time.
- IR COMP** - Set the control speedpot to approximately 50% and note the motor RPM unloaded. Load the motor to normal load condition and adjust IR trimpot CW until motor RPM is equal to unloaded speed.
- C.L.** - Set the control speedpot to approximately 70% and rotate the **CURRENT LIMIT** trimpot fully CCW. Apply a full locked rotor load to the motor. While the motor is stalled, adjust the **CURRENT LIMIT** trimpot CW until a desired current setting is obtained. Approximately 125% of rated motor current is recommended.

NOTE 1:

To properly adjust the **CURRENT LIMIT** setting, a DC ammeter should be placed in series with the armature line. This meter can be removed after the control is adjusted.

NOTE 2:

CL comes factory set to latch off after 3 seconds. For continuous CL operation without Latch off see section Current Limit Function below.

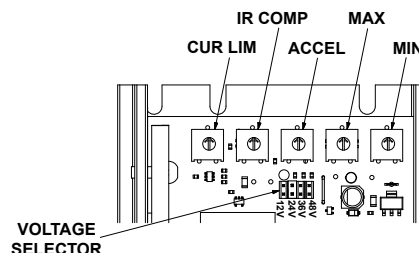

OPTIONS

-UVL

The UVL Option is a factory installed option intended for applications where a battery is used as the source power for the 65E control. The Under Voltage Lockout (UVL) protects the battery from potentially damaging (deep) discharge. The UVL includes two trim pot adjustments: BAT-L and BAT-H. BAT-L is the user-defined voltage level at which the UVL option will shut down the 65E output to the motor when the voltage drops below this setting. BAT-H is the user-defined voltage level at which the UVL option allows the 65E output to resume normal operation. An LED (D1) on the UVL board will illuminate Green when supply voltage is at or above the BAT-H setting. The same LED will illuminate Red when the supply voltage is below the BAT-L setting.

BAT-L and BAT-H adjustments are set by the following procedure:

- 1) Set J1 jumper to proper location based upon supply voltage to the control being used
- 2) Set the Trim pots on the –UVL board to the levels at which you want the drive to shut off and turn back on. Please reference to chart below for approximation of levels.

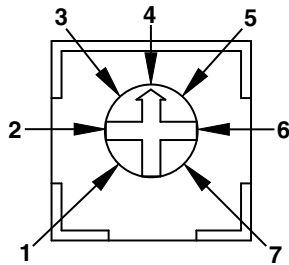

	12.0V*	24.0V*	36.0V*	48.0V*
Under Voltage Trip Point (BAT-L)				
1	10.17	20.34	30.51	40.68
2	10.40	20.80	31.20	41.60
3	10.80	21.60	32.40	43.20
4	11.11	22.22	33.33	44.44
5	11.47	22.94	34.41	45.88
6	11.90	23.80	35.70	47.60
7	12.12	24.24	36.36	48.48
Auto Reset Voltage Point (BAT-H)				
1	12.26	24.52	36.78	49.04
2	12.47	24.94	37.41	49.88
3	12.82	25.64	38.46	51.28
4	13.23	26.46	39.69	52.92
5	13.58	27.16	40.74	54.32
6	14.01	28.02	42.03	56.04
7	14.30	28.60	42.90	57.20

* Battery Voltage

For OEM and other volume users, these values may be hard coded into the UVL processor. Please contact your local or factory Dart Sales representative for more details

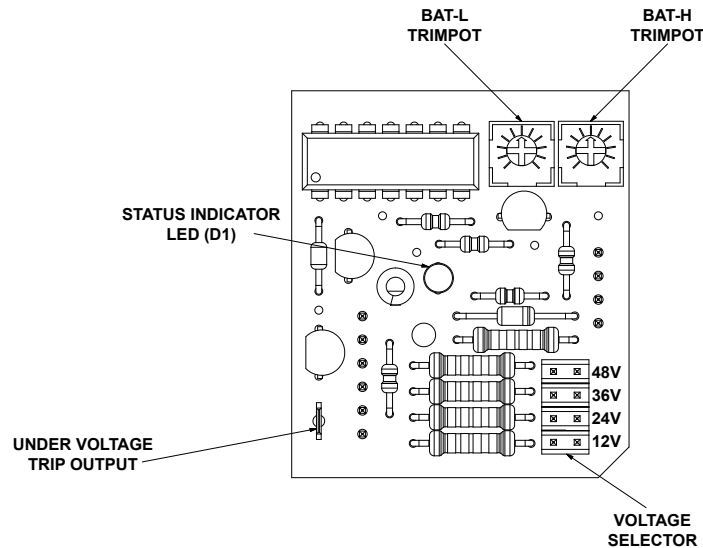

The Under Voltage Trip Pin is an open collector NPN transistor. This will pull low when the input Voltage goes below the Under Voltage Trip Point and stays low until the input Voltage goes above the Auto Reset Voltage Point. This output is rated to 50VDC at 150mA.

Suggested female wire connector for the .110" male spade terminal is Molex Inc. part number 0190030024.

-LED

The LED option is a Factory Installed option available on chassis models only. It provides .110" male spade terminal connections and driver circuits to power customer supplied remote LED's. This may be needed when the chassis control is mounted in a cabinet and it is desirable to see the Power and Current Limit status of the drive. LED's connected to these circuits should have a Maximum Voltage drop of 2.6V or less and be capable of handling 15mA. The remote Power LED is connected to the RPL connectors labeled P5 and P11 (just below the ACCEL trimpot); the remote Current Limit LED is connected to the RCL connectors labeled P9 and P10 (just below the MAX trimpot). This option is standard on all Enclosed models. The Power and Current Limit LED's are located in the cover of the control.

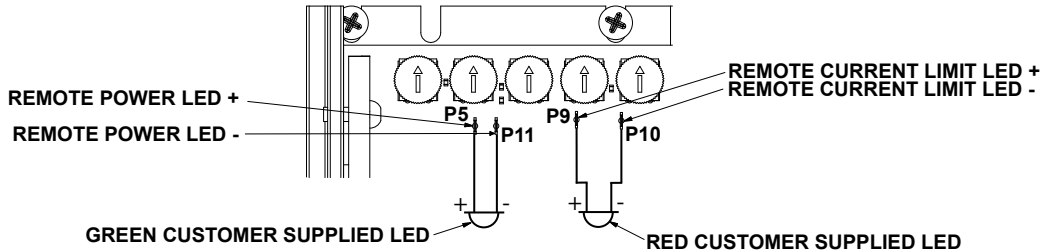

Suggested female wire connector for the .110" male spade terminal is Molex Inc. part number 0190030024.

REMOTE FOLLOWER SIGNALS

The 65E Series will directly accept 0-10Vdc follower signals, in lieu of the manual speed pot. 0-10V signals are NOT required to be isolated at the source. The +Signal is connected directly to the 65E Wiper connection, the -V or Common is connected to the 65E Pot Lo connection.

CURRENT LIMIT FUNCTIONS

When the drive goes into current limit the current limit LED will illuminate and the CL-OUT will be pulled low, if it is used. If the drive remains in current limit for more than 3 seconds the drive will latch the armature output to the motor OFF until the unit is Reset. Reset is accomplished by cycling source power or by Inhibiting the drive (connect P2-4 to P2-5). This will clear the current limit latch.

As an option, the user may override the current limit shutdown / latch action and instead keep the armature output to the motor active, with current allowed to flow determined by the CUR LIM trim pot setting. This may be desirable in applications where the motor load is cyclic and drive shutdowns are not desired. For this action from the drive when in Current Limit, cut the JU1 jumper wire (located below and between the ACCEL and MAX trimpots on the main board).

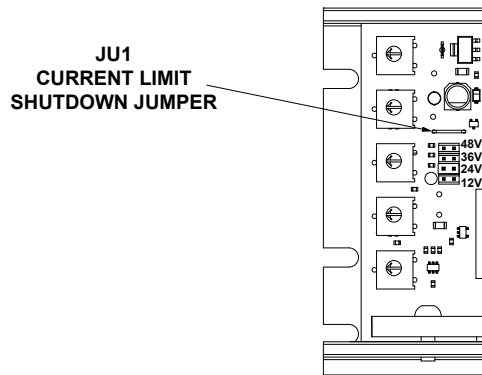

IN CASE OF DIFFICULTY

PROBLEM	POSSIBLE CAUSE(S)	CORRECTIVE ACTION
Motor doesn't run	<ul style="list-style-type: none"> • Incorrect or no power • Speedpot set at zero • Worn motor brushes • Current limit set too low 	Install proper service Rotate speedpot fully CW Replace motor brushes Adjust current limit trimpot CW
Motor "hunts"	<ul style="list-style-type: none"> • Max trimpot set too high • I.R. Comp. trimpot set too high 	See "Trimpot Adjustments" See "Trimpot Adjustments"
Motor runs at "full speed" uncontrollable	<ul style="list-style-type: none"> • Loose speedpot connections • Min. or Max. trimpots not properly adjusted • Possible control failure 	Secure all connections See "Trimpot Adjustments" Send to Dart Controls, Inc.
Motor rotates in wrong direction	<ul style="list-style-type: none"> • Motor armature hooked up backwards 	Reverse armature + and - leads
Motor stalls under a light load	<ul style="list-style-type: none"> • Current limit trimpot improperly adjusted 	See "Trimpot Adjustments"

If a newly installed control will not operate, it is likely that a terminal or connection is loose. Check to make sure connections are secure and correct. If the control is still inoperative, go to www.dartcontrols.com/support or call (317) 873-5211.

MODEL SELECTION

INPUT VOLTAGE	OUTPUT VOLTAGE	CONTINUOUS CURRENT	CONTROL TYPE	MODEL NUMBER
12 - 48 VDC ± 15%	0 to Input voltage	10 Amps D.C.	CHASSIS	65E10C
12 - 48 VDC ± 15%	0 to Input voltage	10 Amps D.C.	ENCLOSED	65E10E
12 - 48 VDC ± 15%	0 to Input voltage	20 Amps D.C.	CHASSIS	65E20C
12 - 48 VDC ± 15%	0 to Input voltage	20 Amps D.C.	ENCLOSED	65E20E

SPECIFICATIONS

	65E10 / 65E10E	65E20 / 65E20E
Load current (continuous)	10 amps	20 amps
Speed adjustment	5K Ohm potentiometer <i>or</i> 0 to +10VDC input signal	
Speed range	30 : 1	
Input Voltage	12-48Vdc +/-15%	
Power Supply Source	Batteries or DC voltage supply	
Overload capacity	200% for 10 seconds; 150% for one minute	
Current limit	adjustable 100% to 200% of full motor load, up to 200% of control current rating	
Current limit output	Up to 50 VDC at 0.3 A	
Acceleration	adjustable - 0 to 10 seconds	
Deceleration	non-adjustable - 0.5 seconds	
Maximum speed	adjustable - 50 to 100% of base speed	
Minimum speed	adjustable - 0 to 30% of max speed	
Power Connections (P1)	Euro-style terminal block (14 Ga. to 28 Ga.)	Euro-style terminal block (10 Ga. to 14 Ga.)
Signal Connections (P2)	Euro-style terminal block (14 Ga. to 28 Ga.)	
Speed regulation	1% of base speed via adjustable IR Compensation trim pot	
Operating temperature	-30° C to +60° C (-22° F to +140° F) for Chassis. -15° C to +45° C (5° F to +113° F) for Enclosed.	
Package configuration	black anodized aluminum extrusion	
Internal operating frequency	approximately 18kHz	

NOTES:

REPAIR PROCEDURE

In the event that a Product manufactured by Dart Controls Incorporated (DCI) is in need of repair service, it should be shipped, freight paid, to: Dart Controls, Inc., 5000 W. 106th Street, Zionsville, IN. 46077, ATTN: Repair Department. Please include Name, Shipping Address (no P.O. Box), Phone Number and if possible, e-mail address.

Those orders received from anyone without an existing account with DCI must specify if they will be paying COD or Credit Card (Master Card/Visa/American Express). This information is required before work will begin. If you have an account with Dart your order will be processed according to the terms listed on your account. Products with Serial Number date codes over 5 years old will automatically be deemed Beyond Economical Repair (BER). A new, equivalent device will be offered at a substantial discount.

Completed repairs are returned with a Repair Report that states the problem with the control and the possible cause. Repair orders are returned via UPS Ground unless other arrangements are made. If you have further questions regarding repair procedures, contact Dart Controls, Inc. at 317-873-5211.

YOUR MOTOR SPEED CONTROL SOLUTION PROVIDER

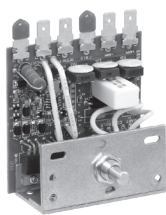

OEM Chassis SCR Drives
Dual Input voltage, adjustable HP range, isolated signal follower and reversing options

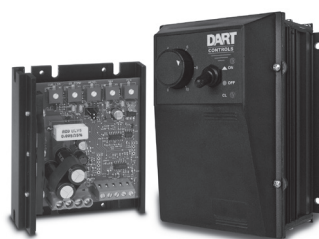
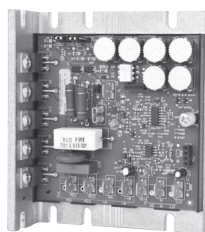

Low Voltage/Battery PWM Drives
Chassis and NEMA 4X versions, speed pot and signal follower operation



Digital SCR Drives

Closed loop accuracy, 4-20mA and serial communications, integral programmable display

Brushless DC Drives

Closed loop accuracy, line and low voltage versions through 1 HP

Digital Accessory & Resale Items

Motors to 700 HP, VFD's to 200 HP, NEMA rated encoder, digital programmable potentiometers and tachometers

Dart Controls, Inc. is a designer, manufacturer, and marketer of analog and digital electronic variable speed drives, controls, and accessories for AC, DC, and DC brushless motor applications.

Shown above is just a sampling of the expanded line of Dart controls that feature the latest in electronic technology and engineering. Products are manufactured in the U.S.A. at our Zionsville (Indianapolis, Indiana)

production and headquarters facility - with over 2,000,000 variable speed units in the field.

In addition to the standard off-the-shelf products, you can select from a wide variety of options to customize controls for your specific application. For further information and application assistance, contact your local Dart sales representative, stocking distributor, or Dart Controls, Inc.

Dart Controls, Inc.

Manufacturer of high quality DC and AC motor speed controls and accessories since 1963.

5000 W. 106th Street
Zionsville, Indiana 46077
Phone: (317) 873-5211
Fax: (317) 873-1105

www.dartcontrols.com
ISO9001 REGISTERED
MADE IN USA