

Installation & Power Connections

Refer to user guide chapter 3.

Typical Control Connection

Example 1: 2 - Wire Start/Stop, Speed Potentiometer

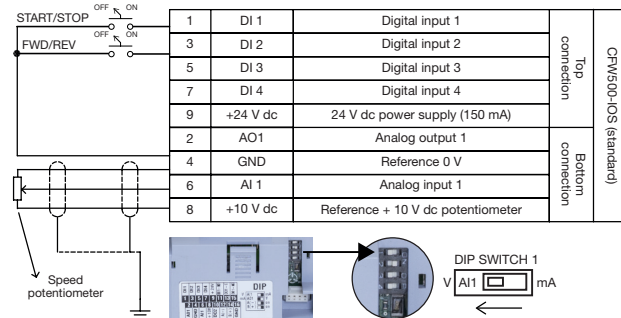

PROG	DEF	User	Description
P0220	2	1	Local/Remote = always remote
P0222	1	1	Remote reference = AI1
P0226	4	4	FWD/REV = Dlx
P0227	1	1	Start/Stop remote = Dlx
P0231	0	0	AI1 = speed reference
P0233	0	0	AI1 = 0 - 10 V
P0263	1	1	DI1 = run/stop
P0264	8	8	DI2 = FWD/REV

Example 2: 3 - Wire Start/Stop, 4 - 20 mA Reference

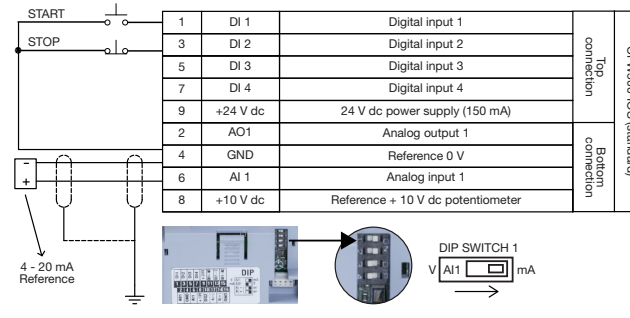

PROG	DEF	User	Description
P0220	2	1	Local/Remote = always remote
P0222	1	1	Remote reference = AI1
P0227	1	1	Run/Stop remote = Dlx
P0231	0	0	AI1 = speed reference
P0233	0	1	AI1 = 4 - 20 mA
P0263	1	6	DI1 = start
P0264	8	7	DI2 = stop

Example 3: 2 - Wire Start/Stop, Multispeed (4 Speeds)

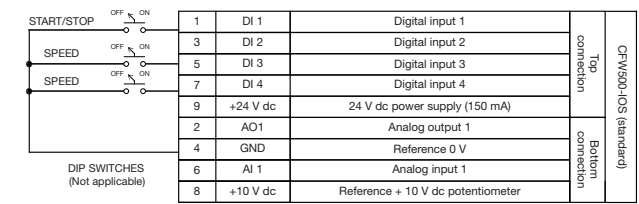

PROG	DEF	User	Description
P0220	0	1	Local/Remote = always remote
P0222	2	8	Remote reference = multispeed
P0227	3	1	Start/Stop remote = Dlx
P0263	1	1	DI1 = start/stop
P0265	0	13	DI3 = multispeed
P0266	0	13	DI4 = multispeed
P0124	3	▲	Speed = ▲ (DI3 = open and DI4 = open)
P0125	10	▲	Speed = ▲ (DI3 = open and DI4 = closed)
P0126	20	▲	Speed = ▲ (DI3 = closed and DI4 = open)
P0127	30	▲	Speed = ▲ (DI3 = closed and DI4 = closed)

Note: ▲ Speed setting depends on application.

Programming

CFW500 Keypad



- Menu/Enter button:**
 - Enter programming mode
 - Use to Select/Save
- Run button:**
 - Run in local mode
- Stop button:**
 - Stop in local mode
 - Reset
- Up/Down buttons:**
 - Adjust speed in local mode
 - Navigate through parameters
- Back/ESC button:**
 - Return to monitoring mode
 - Return to previous programming level

Oriented Start Up - STARTUP Group (Scalar - V/F Mode)

PROG	DEF	User	Description
P0202	0	0	Control type V/F
P0401	-	■	Motor FLC (A)
P0402	1710	■	Motor speed (RPM)
P0403	60	■	Motor frequency

Note: set P0202 = 5 during oriented start-up for improved speed control and higher torque capacity at low speed (especially < 5 Hz).
 ■ Set as per motor nameplate data.

Motor Overload Settings - MOTOR Group

PROG	User	Description
P0156	1.1xP0401	Overload current at 100% speed
P0157	1.0xP0401	Overload current at 50% speed
P0158	0.8xP0401	Overload current at 5% speed

Basic Application - BASIC Group

PROG	DEF	Description
P0100	10s	Acceleration time (s)
P0101	10s	Deceleration time (s)
P0133	3 Hz	Minimum speed (Hz)
P0134	66 Hz	Maximum speed (Hz)

Relay Output

PROG	DEF	User	Description
11	DO1-RL-NO	Normally open	
13	DO1-RL-C	Common	
15	DO1-RL-NC	Normally closed	
P0275	13	11	Run
		12	Ready
		13	No fault
		26	With fault

Note: for more advance functions, please refer to the the programming manual.

Changing Monitor Display Parameter

PROG	DEF	User	Description
P0205	P0205 = 2	1	Speed reference (RPM)
P0206	P0206 = 1	2	Output speed (RPM)
		3	Motor current (A)
		5	Output frequency (Hz)
		7	Output voltage (V)
		9	Motor torque (%)

Secondary display P0206
Main display P0205

Note: for more advance functions, please refer to the programming manual (chapter 5.3).

Loading Factory Default Setting

PROG	DEF	User	Description
P0204	0	5	Load factory defaults (60 Hz)

Applications

- Centrifugal pumps
- Process dosing pumps
- Fans/ventilators
- Blenders/mixers
- Compressors
- Conveyors
- Roller tables
- Granulators
- Commercial dryers
- Rotary filters

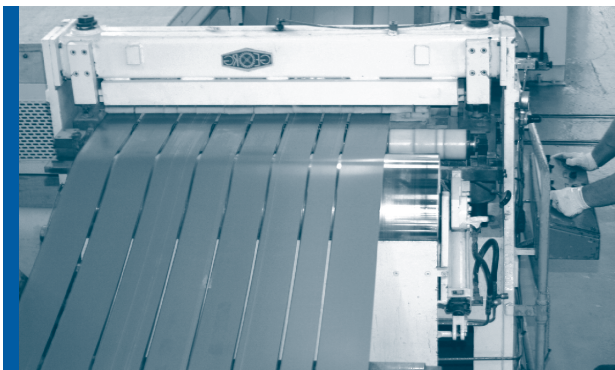

WEG Electric Corp.
6655 Sugarloaf Parkway
Duluth, GA 30097
Phone: 1-800-ASK-4WEG
www.weg.net



Motors | Automation | Energy | Transmission & Distribution | Coatings

CFW500 Machinery Drives

Quick Setup Guide



Code: xxxx | Rev: 00 | Date (m/y): 06/2014
The values shown are subject to change without prior notice.

