

Safety Switches with Separate Actuator and Interlock

SLK

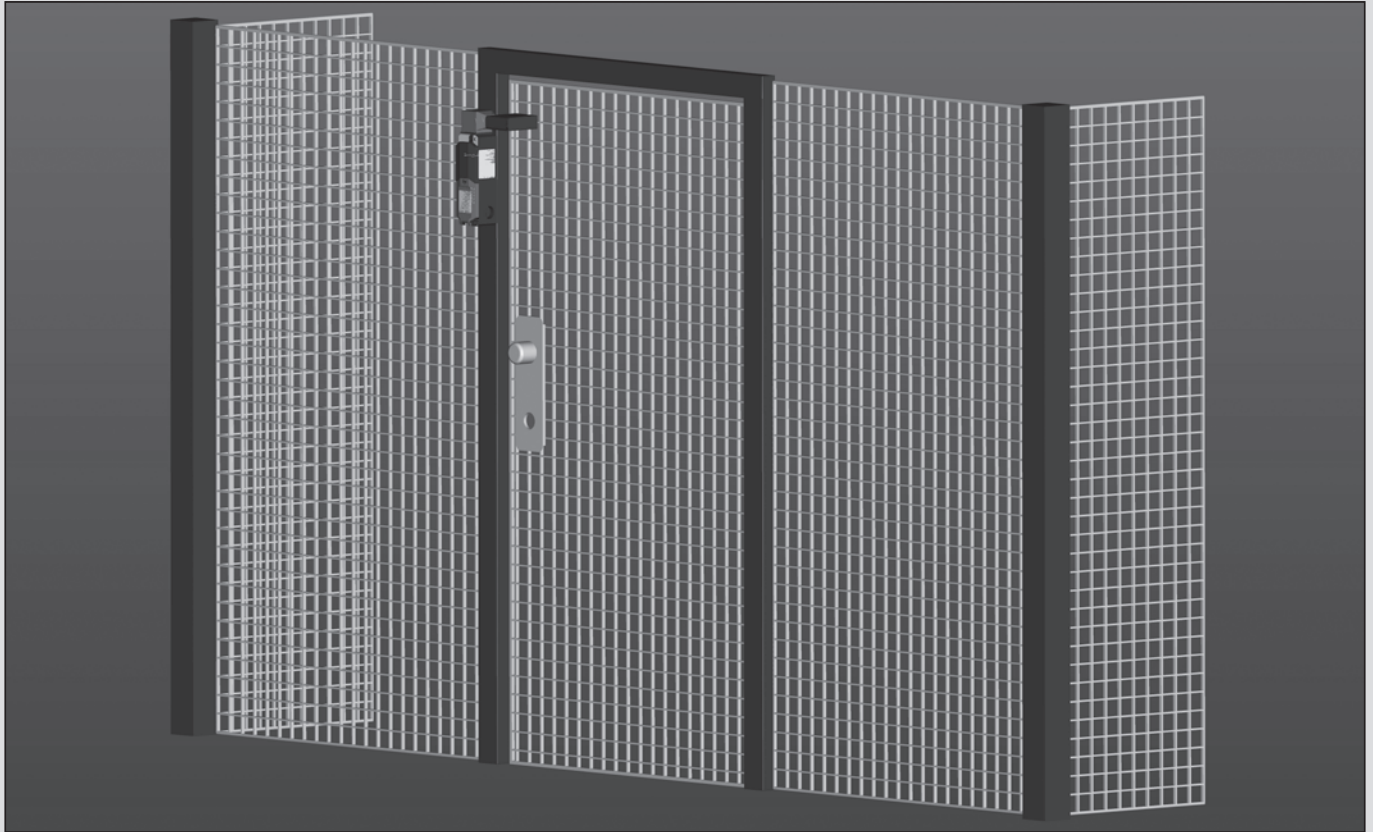

Machines that continue running after being switched off are often part of automated production processes. Safety guards prevent operator access and must therefore be kept closed until the hazards posed by machine movement have ceased.

Safety position switches with interlock function ensure that safety gates, safety doors and other protective guards remain closed for as long as a hazardous situation exists.

In production processes safety position switches have three main tasks:

- Enabling the machine / process when the safety guard is closed and interlocked
- Disabling the machine / process when the safety guard is opened
- Position monitoring of the safety guard and interlock

The SLK safety position switches with separate actuators and interlock enable the user to realise locking systems conforming to EN 1088, EN ISO 12100-1, 12100-2 and since 29.12.2009 to the compulsory Machinery Directive 2006/42/EC.

System description

SLK safety position switches with interlock function are available in versions with spring force locking action and magnetic force locking action. The separate actuator is connected formfit with the safety guard. It transfers the locking force to the safety guard and monitors its position. Thanks to its triple coding, the separate actuator ensures a high degree of antitamper security. The interlock facility in association with the SLK safety position switches is integrated in the switch enclosure. To lock the actuator in connection with a switching mechanism, the required interlock is achieved by means of a spring mechanism in the spring force locked version and by an electromagnet in the magnetic force locked version.

Locking principle

Spring force (closed-circuit current)

The interlock is activated when the actuator is fully inserted. The interlock is released by energising the electromagnet, allowing the safety guard to be opened.

Magnetic force (working current)

The interlock is deactivated when the electromagnet is de-energised in the event of a power failure. This allows the safety guard to be opened.

Product advantages

- Two independent safety circuits ensure reliable integration
 - With two contacts, circuit 1 monitors the actuator
 - With two contacts, circuit 2 monitors the interlock

The contact configuration is variable and may deviate from the selection table if required.
- Two different operating voltages for universal integration:
 - 24 V AC / DC
 - 110 V / 230 V AC
- Rotary actuating head (4x 90°) as well as horizontal and vertical actuation ensure complete flexibility in use
- Compact design with short overall size of only 170 mm
- Innovative installation with spring-loaded terminals
- Function conforming to GS ET 19, EN 60 204-1, EN 60 947-1 and EN 60 947-5-1

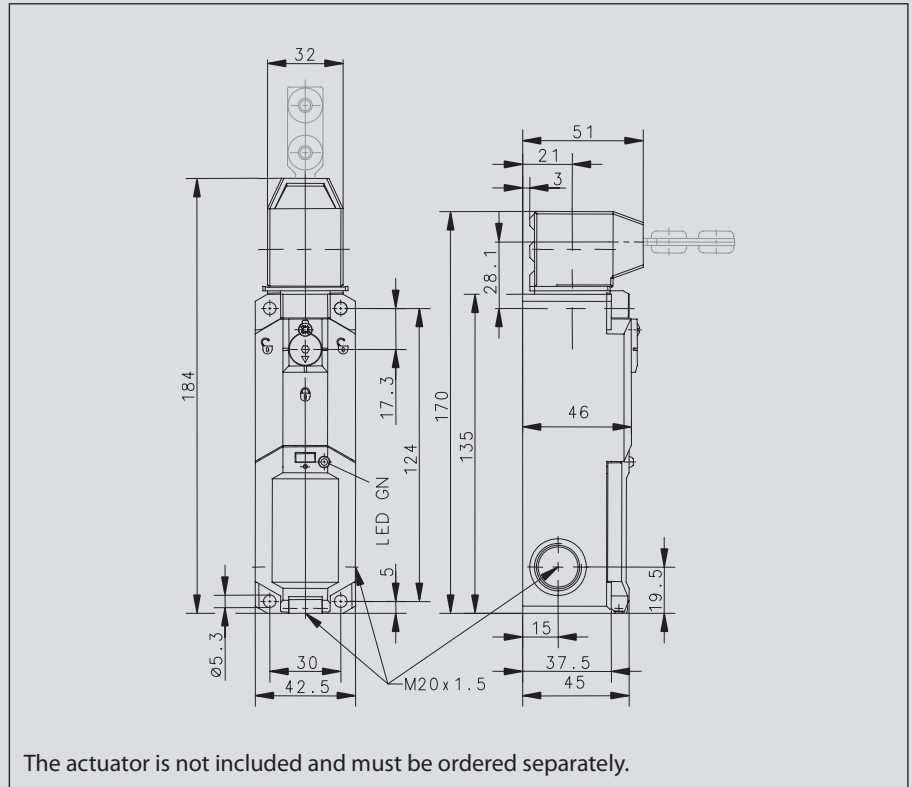

Safe operation

The stainless steel actuator ensures safe and reliable operation. Its coding prevents tampering and bypassing the system "in an easier way". The radius actuator is ideal for monitoring smaller safety gates. It can be preset horizontally or vertically and is also made from stainless steel.

Flexible in use

The SLK safety switch can be actuated in a horizontal and vertical direction. Prior to installation it is preset by simply repositioning the head section. This flexibility in installation is achieved by positioning the actuator head in steps of 4 x 90°.

New symbol according to ISO 14119 for the interlocking contact:

Contacts labelled with this symbol in the switching travel diagram in the operating and installation instructions are safely positively driven contacts which monitor the interlocking position.

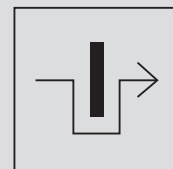
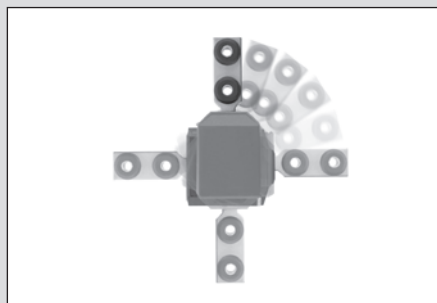

Innovative installation

The SLK is electrically connected safely and reliably by means of terminals. Spring loaded terminals are used, into which the wires with ferrules can be inserted without the need for tools. The fact that the connection compartment is separate from the functional parts contributes to ensuring secure and reliable connection. The connection compartment conforms to protection class IP67.

IMPORTANT: The actuator for the SLK must be ordered separately. You will find a corresponding overview on Pages 92 – 93.

Safety Switches with Separate Actuator and Interlock

SLK

Product selection

Article number	Designation	Locking action	Supply voltage	Contacts		Additional function
				Actuator	Interlock	
6018119045	SLK-F-UC-55-R1-A0-L0-0	Spring	24 Volt AC / DC	1NC / 1NO	1NC / 1NO	Auxiliary release
6018119066	SLK-F-UC-55-R1-A0-L1-0	Spring	24 Volt AC / DC	1NC / 1NO	1NC / 1NO	Auxiliary release, LED
6018169054	SLK-F-UC-22-R1-A0-L0-0	Spring	24 Volt AC / DC	2 NC	2 NC	Auxiliary release
6018169050	SLK-F-UC-25-R1-A0-L0-0	Spring	24 Volt AC / DC	2 NC	1NC / 1NO	Auxiliary release
6018169068	SLK-F-UC-25-R1-A0-L1-0	Spring	24 Volt AC / DC	2 NC	1NC / 1NO	Auxiliary release, LED
6018119061	SLK-F-UC-55-R2-A0-L0-0	Spring	24 Volt AC / DC	1NC / 1NO	1NC / 1NO	Emergency release
6018169055	SLK-F-NC-22-R1-A0-L0-0	Spring	110 / 230 AC	2 NC	2 NC	Auxiliary release
6018119046	SLK-F-NC-55-R1-A0-L0-0	Spring	110 / 230 AC	1NC / 1NO	1NC / 1NO	Auxiliary release
6018119067	SLK-F-NC-55-R1-A0-L1-0	Spring	110 / 230 AC	1NC / 1NO	1NC / 1NO	Auxiliary release, LED
6018169051	SLK-F-NC-25-R1-A0-L0-0	Spring	110 / 230 AC	2 NC	1NC / 1NO	Auxiliary release
6018169069	SLK-F-NC-25-R1-A0-L1-0	Spring	110 / 230 AC	2 NC	1NC / 1NO	Auxiliary release, LED
6018119047	SLK-M-UC-55-R0-A0-L0-0	Magnet	24 Volt AC / DC	1NC / 1NO	1NC / 1NO	
6018169052	SLK-M-UC-25-R0-A0-L0-0	Magnet	24 Volt AC / DC	2 NC	1NC / 1NO	
6018169056	SLK-M-UC-22-R0-A0-L0-0	Magnet	24 Volt AC / DC	2 NC	2 NC	
6018119048	SLK-M-NC-55-R0-A0-L0-0	Magnet	110 / 230 AC	1NC / 1NO	1NC / 1NO	
6018169053	SLK-M-NC-25-R0-A0-L0-0	Magnet	110 / 230 AC	2 NC	1NC / 1NO	
6018169057	SLK-M-NC-22-R0-A0-L0-0	Magnet	110 / 230 AC	2 NC	2 NC	

Technical data

Technical data	Spring	Spring	Magnet	Magnet
	24 Volt AC / DC	110 / 230 AC	24 Volt AC / DC	110 / 230 AC
Electrical data				
Rated insulation voltage U_i	250 V	250 V	250 V	250 V
Utilization category	AC-15, U_e / I_e 230 V / 2.5 A	AC-15, U_e / I_e 230 V / 2.5 A	AC-15, U_e / I_e 230 V / 2.5 A	AC-15, U_e / I_e 230 V / 2.5 A
Conventional thermal current I_{the}	5 A	5 A	5 A	5 A
Short-circuit protection	4 A gL	4 A gL	4 A gL	4 A gL
Protection class	II, Insulated	II, Insulated	II, Insulated	II, Insulated
Electromagnet				
Duty factor	100 % ED (an E1; E2)	100 % ED (an E1; E2)	100 % ED (an E1; E2)	100 % ED (an E1; E2)
Thermal class	F (155 °C)	F (155 °C)	F (155 °C)	F (155 °C)
Switch-on power	12 VA (0.2 s)	65 VA (0.1 s)	12 VA (0.2 s)	65 VA (0.1 s)
Continuous power	4.4 VA	8 VA	4.4 VA	8 VA
Mechanical data				
Enclosure	Thermoplastic GV (UL94-V0)	Thermoplastic GV (UL94-V0)	Thermoplastic GV (UL94-V0)	Thermoplastic GV (UL94-V0)
Cover	Thermoplastic GV (UL94-V0)	Thermoplastic GV (UL94-V0)	Thermoplastic GV (UL94-V0)	Thermoplastic GV (UL94-V0)
Actuator	Thermoplastic GV / Zn-GD	Thermoplastic GV / Zn-GD	Thermoplastic GV / Zn-GD	Thermoplastic GV / Zn-GD
Ambient temperature	-25 °C to + 70 °C	-25 °C to + 70 °C	-25 °C to + 70 °C	-25 °C to + 70 °C
Switching function	2 NC contacts, 2 NO contacts	2 NC contacts, 2 NO contacts	4 NC contacts	2 NC contacts, 2 NO contacts
Switching principle	4 Slow-action contacts	4 Slow-action contacts	4 Slow-action contacts	4 Slow-action contacts
Mechanical service life	1 x 10 ⁶ switching cycles (max. 600 switching cycles / h)	1 x 10 ⁶ switching cycles (max. 600 switching cycles / h)	1 x 10 ⁶ switching cycles (max. 600 switching cycles / h)	1 x 10 ⁶ switching cycles (max. 600 switching cycles / h)
B10d	2 mill.	2 mill.	2 mill.	2 mill.
Minimum actuating radius R_{min}	See datasheet, actuator	See datasheet, actuator	See datasheet, actuator	See datasheet, actuator
Approach speed V_{max}	0.5 m/s	0.5 m/s	0.5 m/s	0.5 m/s
Mounting	4 x M5	4 x M5	4 x M5	4 x M5
Cross sections	0.5 – 1.5 mm ²	0.5 – 1.5 mm ²	0.5 – 1.5 mm ²	0.5 – 1.5 mm ²
Type of connection	Cage clamp terminal	Cage clamp terminal	Cage clamp terminal	Cage clamp terminal
Cable entry	3 x M20 x 1.5	3 x M20 x 1.5	3 x M20 x 1.5	3 x M20 x 1.5
Weight	≈ 0.34 kg	≈ 0.30 kg	≈ 0.30 kg	≈ 0.35 kg
Protection class	IP67 conforming to IEC/EN 60529	IP67 conforming to IEC/EN 60529	IP67 conforming to IEC/EN 60529	IP67 conforming to IEC/EN 60529
Installation position	Any	Any	Any	Any
Locking principle	Spring force	Spring force	Magnetic force	Magnetic force
Latching force	FZh ≤ 1500 N to GS-ET-19	≤ 1500 N to GS-ET-19	≤ 1500 N to GS-ET-19	≤ 1500 N to GS-ET-19

Approvals:



Safety Switches with Separate Actuator and Interlock

Product selection SLK, ENK-VTU, ENM2-VTW

Article number	Designation
3911702228	Actuator A1

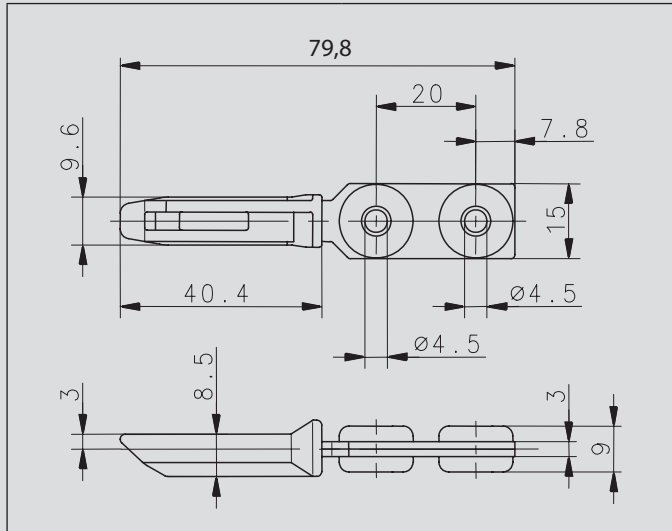

Mechanical data		
Actuator		Steel/PA
Minimum actuating radius	R _{min}	400 mm

Article number	Designation
3911702231	Actuator A4

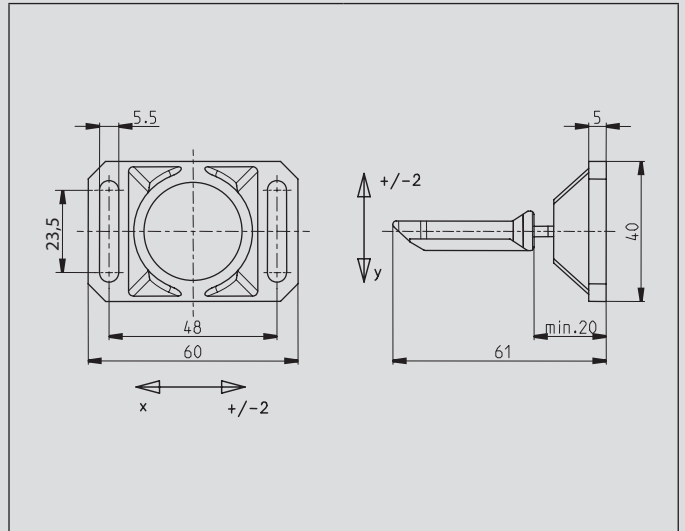

Mechanical data		
Actuator		Steel/PA
Enclosure		GD-Zn
Minimum actuating radius	R _{min}	350 mm
Repositioning of spring-mounted actuator by 4 x 90° in mounted state.		

Article number	Designation
3911702229	Actuator A2

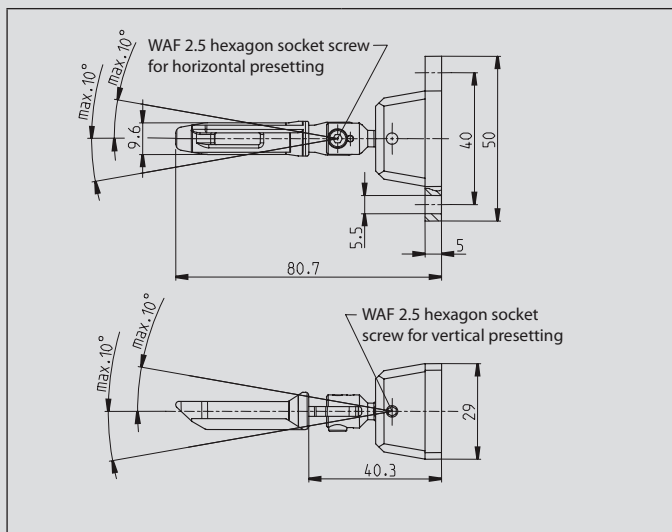

Mechanical data		
Enclosure / Actuator		Steel/PA
Minimum actuating radius	R _{min}	150 mm
Repositioning of spring-mounted actuator by 4 x 90° in not mounted state.		
WAF 2.5 Allen key, supplied		

Article number	Designation
3911702230	Actuator A3

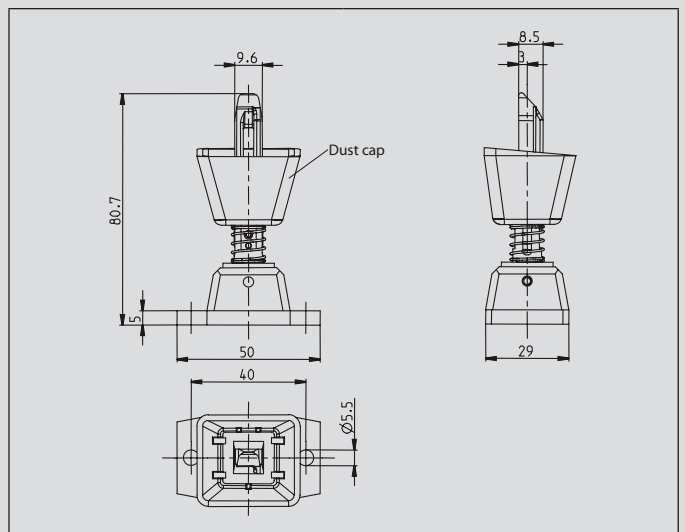

Mechanical data		
Enclosure / Actuator		Steel/PA
Dust cap		Elastomer CR
Minimum actuating radius	R _{min}	400 mm
Repositioning of spring-mounted actuator by 4 x 90° in not mounted state.		

Article number	Designation
3911702234	Actuator A7

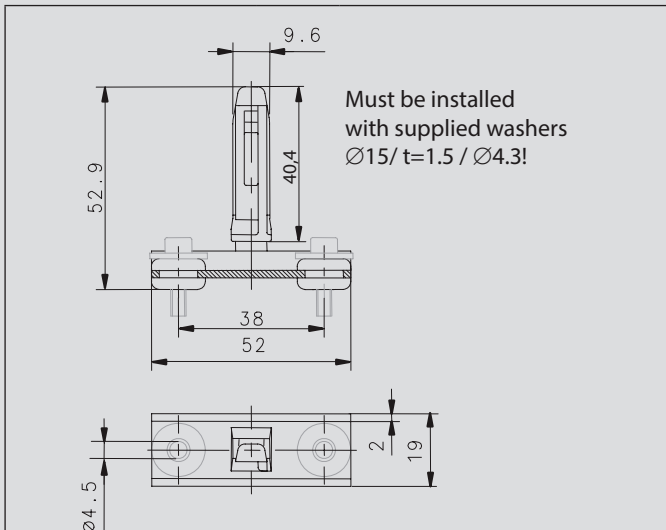

Mechanical data		
Actuator		Steel/PA
U-section		Steel
Minimum actuating radius	R_{min}	400 mm