

# Incremental encoders

Insulated through hollow shaft  $\varnothing 0.375...1$  inch

1024...80000 pulses per revolution

## HS35F



HS35F with insulated hollow shaft

### Features

- Robust industrial encoder up to IP 67 protection
- Shock resistant up to 200 g's
- Insulating insert to prevent high shaft currents from damaging bearings
- Wide range voltage supply 4.75...30 VDC
- Precision  $\leq 60$  arc-seconds for perfect process control
- Max. 80000 pulses per revolution

### Technical data - electrical ratings

Voltage supply	4.75...30 VDC
Reverse polarity protection	Yes
Consumption w/o load	$\leq 40$ mA (24 VDC) $\leq 130$ mA (4.75 VDC) + output load, max. 250 mA
Pulses per revolution	1024...80000
Accuracy	$\leq 60$ arc-seconds
Sensing method	Optical
Output frequency	$\leq 300$ kHz (TTL) $\leq 160$ kHz (HTL) $\leq 160$ kHz (OC)
Output signals	A, B, Z A, B, Z + complement, $\frac{1}{2}$ cycle index gated with negative B channel
Output stages	Linedriver (TTL, 7272) Vout = 5 V, short-circuit proof Push-pull (HTL, 7272) Vout = Vin, short-circuit proof Open Collector (OC, 7273) Vout = Vin, short-circuit proof
Interference immunity	DIN EN 61000-6-2
Emitted interference	DIN EN 61000-6-3
Approvals	UL approval / file no. E240061, ROHS compliant EU guideline 2011/65/EC, CE

### Technical data - mechanical design

Size (flange)	$\varnothing 3.15"$ ( $\varnothing 80$ mm)
Shaft type	$\varnothing 0.375...1"$ ( $\varnothing 9.525...25.4$ mm) (through hollow shaft isolated)
Bore runout	0.0016" (0.04 mm) TIR max.
Admitted misalignment	0.004" (0.1016 mm) radial TIR (end of shaft) 0.01" (0.254 mm) axial
Protection DIN EN 60529	IP 54, IP 65, IP 67
Operating speed	$\leq 5000$ rpm (see temperature diagram)
Bearing	52100 SAE high carbon steel (ABEC 5)
Starting torque	$\leq 3$ in-oz (77 °F, IP 65) $\leq 0.02$ Nm (+25 °C, IP 65)
Rotor moment of inertia	2.3 oz-in <sup>2</sup> (420 gcm <sup>2</sup> )
Service life	Bearing: typ. 13 billion rev. (89000 h/2500 rpm)
Materials	Housing: aluminium, powder-coated Shaft: stainless steel
Operating temperature	-40...+212 °F (-40...+100 °C), (fixed cable): see temperature diagram
Relative humidity	98 % non-condensing
Resistance	DIN EN 60068-2-6 Vibration 20 g, 60-2000 Hz DIN EN 60068-2-27 Shock 200 g, 6 ms
Connection	MIL-connector, 7-pin MIL-connector, 10-pin Cable (AWG26 wire)
Weight approx.	23 oz., 660 g

# Incremental encoders

## Insulated through hollow shaft $\varnothing 0.375...1$ inch

### 1024...80000 pulses per revolution

**HS35F**

**Part number**

HS35F 

					<b>E</b>		
--	--	--	--	--	----------	--	--

Mounting kit

- T1 Tether arm T1, fixed length, for bolt 3/8"
- T3 Tether arm T3, adjustable length, for bolt 1/4"
- T4 Tether arm T4, adjustable length, for bolt 5/16"
- T5 Tether arm T5, adjustable length, for bolt 3/8"

Protection

- 4 IP 54
- 5 IP 65
- 7 IP 67 (dust cap included)

Through hollow shaft

- |   |                         |
|---|-------------------------|
| 100 $\varnothing 1.000''$ ( $\varnothing 25.4$ mm)  | M18 $\varnothing 18$ mm |
| 087 $\varnothing 0.875''$ ( $\varnothing 22.23$ mm) | M16 $\varnothing 16$ mm |
| 075 $\varnothing 0.750''$ ( $\varnothing 19.05$ mm) | M15 $\varnothing 15$ mm |
| 062 $\varnothing 0.625''$ ( $\varnothing 15.88$ mm) | M14 $\varnothing 14$ mm |
| 050 $\varnothing 0.500''$ ( $\varnothing 12.7$ mm)  | M12 $\varnothing 12$ mm |
| 037 $\varnothing 0.375''$ ( $\varnothing 9.525$ mm) | M10 $\varnothing 10$ mm |
| M20 $\varnothing 20$ mm                             |                         |

Operating temperature

E  $-40...+212$  °F ( $-40...+100$  °C)

Phasing

- B Standard phasing, CCW rotation, A leads B
- D Phasing option, CW rotation, A leads B

Connection

- MI07 MIL-connector, 7-pin (at ABZ)
- MI10 MIL-connector, 10-pin (at ABZC)
- C012 Cable gland with cable and wire end sleeves L=12" (305 mm)
- C018 Cable gland with cable and wire end sleeves L=18" (457 mm)
- C024 Cable gland with cable and wire end sleeves L=24" (610 mm) \*\*

Output signals

- ABZ\_ A, B, Z
- ABZC A, B, Z + complements

Voltage supply / signals

- T  $V_{in} = 4.75...30$  VDC,  $V_{out} = 5$  V (7272) / TTL-signals
- H  $V_{in} = 4.75...30$  VDC,  $V_{out} = V_{in}$  (7272) / HTL-signals
- O  $V_{in} = 4.75...30$  VDC,  $V_{out} = V_{in}$  (7273) / Open Collector (OC), (external pull-up resistor required)

Pulse number - see table

**Pulse number**

01024	03072	08192*	20000*	80000*
02000	03600	10000*	25000*	
02048	04096	15000*	32768*	
02500	05000	16384*	40000*	

\* Pulse numbers are interpolated.  
 \*\* Other cable lengths on request.

# Incremental encoders

Insulated through hollow shaft  $\varnothing 0.375 \dots 1$  inch

1024...80000 pulses per revolution

## HS35F

### Output signals

Phasing = B: Counterclockwise rotation (standard) from clamping end.  
Phasing = D: Clockwise rotation (option) from clamping end.

#### ABZ-Output signals

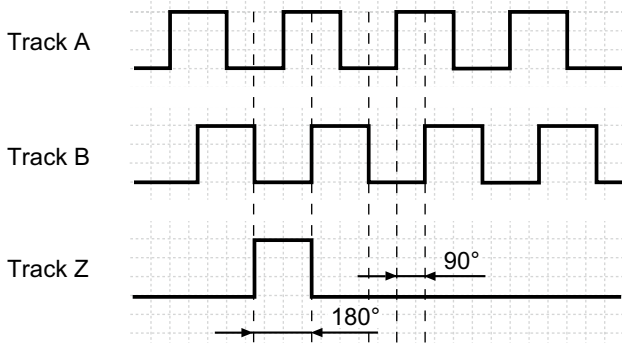

#### ABZC-Output signals

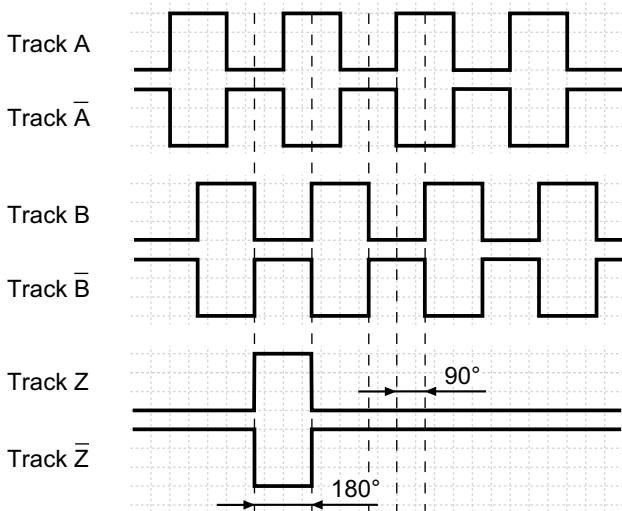

### Terminal assignment

#### MI07: MIL-connector, 7-pin

Connector	Assignment
Pin A	Track A
Pin B	Track B
Pin C	Track Z
Pin D	+Vs
Pin E	-
Pin F	0 V
Pin G	Housing

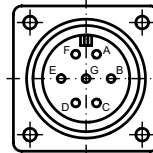

#### MI10: MIL-connector, 10-pin

Connector	Assignment
Pin A	Track A
Pin B	Track B
Pin C	Track Z
Pin D	+Vs
Pin E	-
Pin F	0 V
Pin G	Housing
Pin H	Track A complement
Pin I	Track B complement
Pin J	Track Z complement

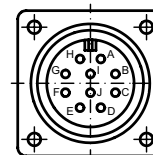

#### Cable gland (AWG26 wire)

Core colour	Assignment
green	Track A
grey	Track B
pink	Track Z
red	+Vs
blue	0 V
transparent	Shield/Housing
brown	Track A complement
black	Track B complement
white	Track Z complement

# Incremental encoders

## Insulated through hollow shaft $\varnothing 0.375...1$ inch

### 1024...80000 pulses per revolution

HS35F

#### Trigger level

Outputs	Linedriver (TTL, ET7272)
Output level High	$\geq 2.4$ V
Output level Low	$\leq 0.5$ V
Load	$\leq 40$ mA

#### Outputs

Outputs	Push pull (HTL, ET7272)
Output level High	$\geq U_B - 3$ V
Output level Low	$\leq 1.5$ V
Load	$\leq 40$ mA

#### Temperature diagram

ambient temperature + self heating  
 $\leq$  max. operating temperature  $+212$  °F ( $+100$  °C)

self-heating per 1000 rpm:

IP 54:  $+9$  °F ( $+5$  °C)  
 IP 65:  $+18$  °F ( $+10$  °C)  
 IP 67:  $+27$  °F ( $+15$  °C)

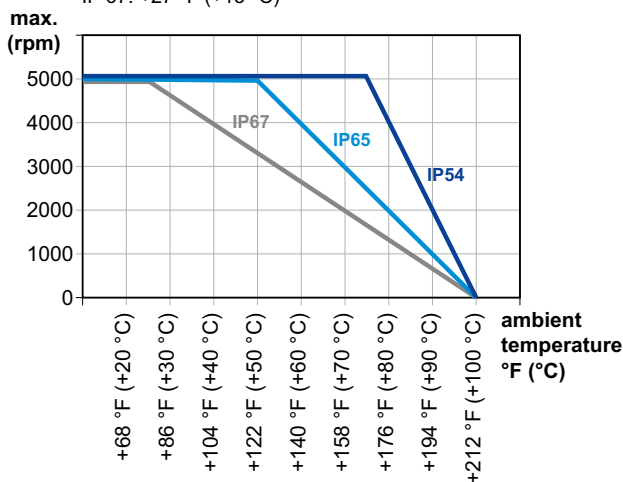

#### Accessories

##### Connectors and cables

11128642	NAC 25E 7-pin Mil Spec Mating Connector
11078440	CNAC 25E 7-pin Mil Spec Mating Connector + cable L = 10 feet (3.05 m)
11078442	CNAC 25E 7-pin Mil Spec Mating Connector + cable L = 20 feet (6.10 m)
11078446	CNAC 25E 7-pin Mil Spec Mating Connector + cable L = 30 feet (9.15 m)
11126235	NAC 29H 10-pin Mil Spec Mating Connector
11078307	CNAC 29H 10-pin Mil Spec Mating Connector + cable L = 10 feet (3.05 m)
11078427	CNAC 29H 10-pin Mil Spec Mating Connector + cable L = 20 feet (6.10 m)
11078428	CNAC 29H 10-pin Mil Spec Mating Connector + cable L = 30 feet (9.15 m)

##### Mounting accessories

11076339	Torque arm T1, fixed length, for bolt 3/8" with plastic clip and screws
11075692	Torque arm T3, adjustable length, for bolt 1/4" with plastic clip and screws
11075690	Torque arm T4, adjustable length, for bolt 5/16" with plastic clip and screws
11071506	Torque arm T5, adjustable length, for bolt 3/8" with plastic clip and screws
11084462	Reducer insert HS35 $\varnothing 0.375$ " ( $\varnothing 9.525$ mm)
11078636	Reducer insert HS35 $\varnothing 0.50$ " ( $\varnothing 12.7$ mm)
11080114	Reducer insert HS35 $\varnothing 0.625$ " ( $\varnothing 15.875$ mm)
11078639	Reducer insert HS35 $\varnothing 0.75$ " ( $\varnothing 19.05$ mm)
11078654	Reducer insert HS35 $\varnothing 0.87$ " ( $\varnothing 22.225$ mm)
11087744	Reducer insert HS35 $\varnothing 10$ mm
11087745	Reducer insert HS35 $\varnothing 12$ mm
11087746	Reducer insert HS35 $\varnothing 14$ mm
11148651	Reducer insert HS35 $\varnothing 15$ mm
11087747	Reducer insert HS35 $\varnothing 16$ mm
11087748	Reducer insert HS35 $\varnothing 18$ mm
11087750	Reducer insert HS35 $\varnothing 20$ mm
11075459	Dust cap HS35
11080884	Protective cage HS35

# Incremental encoders

Insulated through hollow shaft  $\varnothing 0.375...1$  inch

1024...80000 pulses per revolution

## HS35F

### Dimensions

#### HS35F

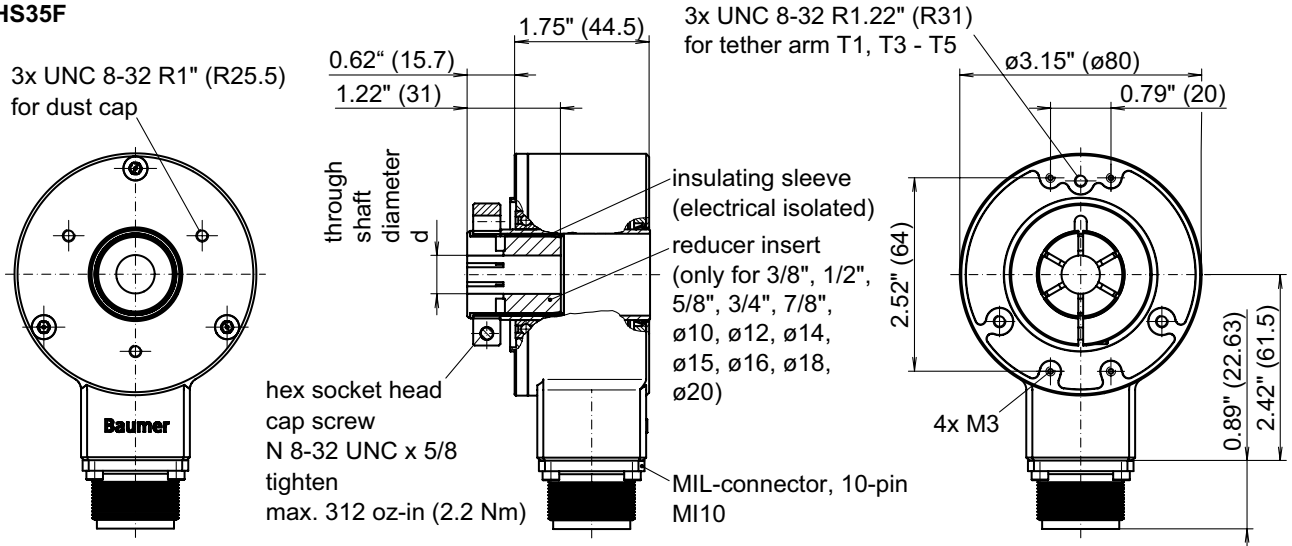

$\varnothing$ nominal dimension		tolerance						
		hollow shaft encoder				recommended customer shaft		
inch (in ")	metric (in mm)		inch (in 1/1000")	metric (in $\mu$ m)		inch (in 1/1000")	metric (in $\mu$ m)	
1.000"	25.400	G7	+1.10 +0.28	+28 +7	h6	0 -0.51	0 -13	
0.875"	22.225	G7	+1.10 +0.28	+28 +7	h6	0 -0.51	0 -13	
0.750"	19.050	G7	+1.10 +0.28	+28 +7	h6	0 -0.51	0 -13	
0.625"	15.875	G7	+0.94 +0.24	+24 +6	h6	0 -0.43	0 -11	
0.500"	12.700	G7	+0.94 +0.24	+24 +6	h6	0 -0.43	0 -11	
0.375"	9.525	G7	+0.79 +0.20	+20 +5	h6	0 -0.35	0 -9	
0.787"	20	H8	+1.30 0	+33 0	g6	-0.28 -0.79	-7 -20	
0.709"	18	H8	+1.06 0	+27 0	g6	-0.24 -0.67	-6 -17	
0.630"	16	H8	+1.06 0	+27 0	g6	-0.24 -0.67	-6 -17	
0.591"	15	H8	+1.06 0	+27 0	g6	-0.24 -0.67	-6 -17	
0.551"	14	H8	+1.06 0	+27 0	g6	-0.24 -0.67	-6 -17	
0.472"	12	H8	+1.06 0	+27 0	g6	-0.24 -0.67	-6 -17	
0.394"	10	H8	+1.06 0	+27 0	g6	-0.20 -0.55	-5 -14	

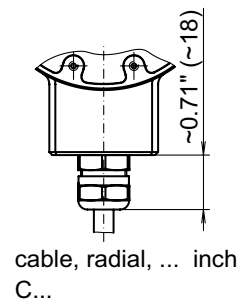
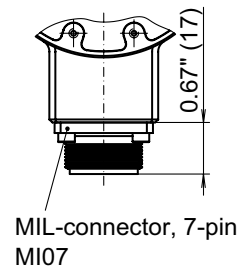

# Incremental encoders

Insulated through hollow shaft  $\varnothing 0.375...1$  inch  
1024...80000 pulses per revolution

HS35F

## Dimensions

Tether arm T1

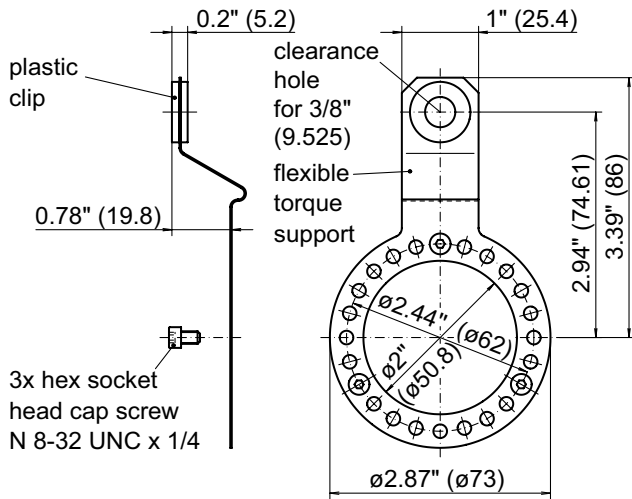

Tether arm T3

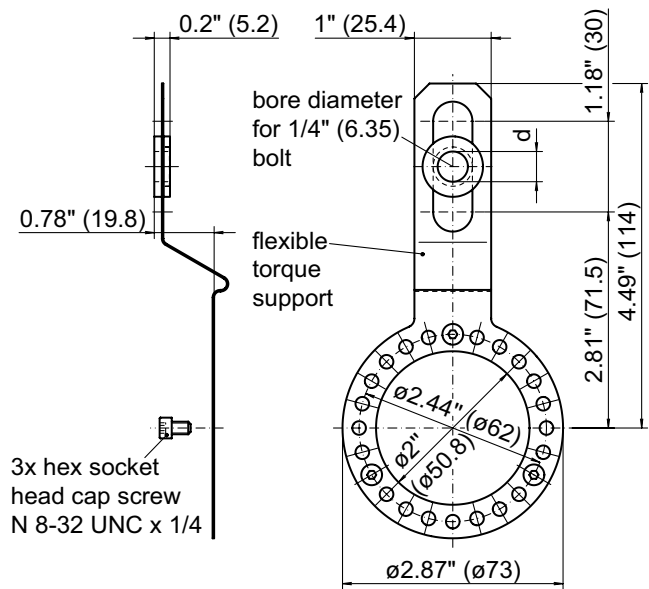

Tether arm T4

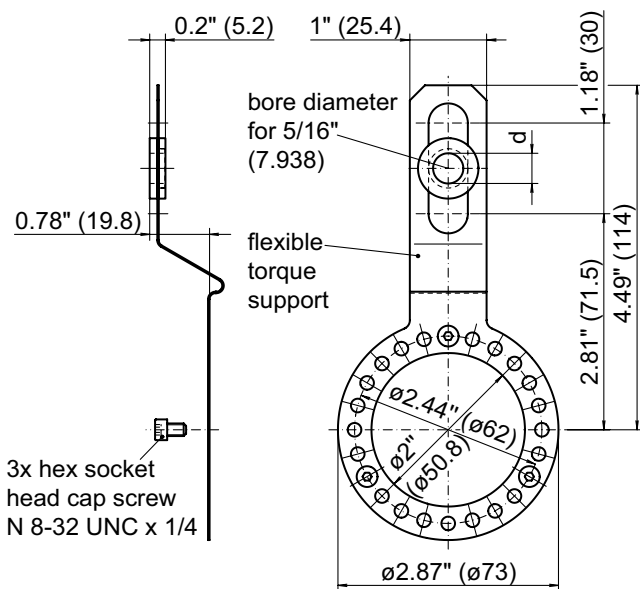

Tether arm T5

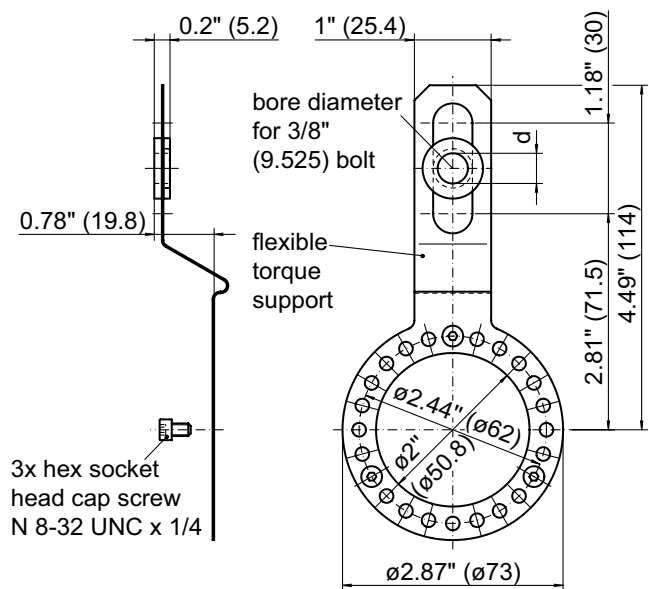

3x hex socket head cap screw N 8-32 UNC x 1/4

3x hex socket head cap screw N 8-32 UNC x 1/4

# Incremental encoders

Insulated through hollow shaft  $\varnothing 0.375...1$  inch

1024...80000 pulses per revolution

## HS35F

### Dimensions

#### Reducer inserts

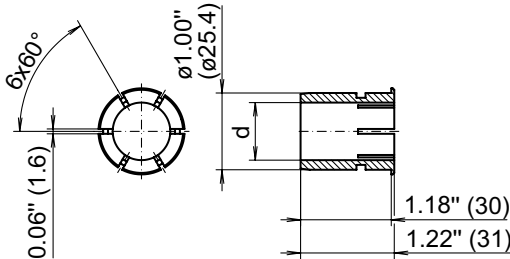

ø nominal dimension		tolerance		
inch (in ")	metric (in mm)		inch (in 1/1000")	metric (in µm)
0.875"	22.225	G7	+1.10 +0.28	+28 +7
0.750"	19.050	G7	+1.10 +0.28	+28 +7
0.625"	15.875	G7	+0.94 +0.24	+24 +6
0.500"	12.700	G7	+0.94 +0.24	+24 +6
0.375"	9.525	G7	+0.79 +0.20	+20 +5
0.787"	20	H8	+1.30 0	+33 0
0.709"	18	H8	+1.06 0	+27 0
0.630"	16	H8	+1.06 0	+27 0
0.551"	15	H8	+1.06 0	+27 0
0.551"	14	H8	+1.06 0	+27 0
0.472"	12	H8	+1.06 0	+27 0
0.394"	10	H8	+1.06 0	+27 0

#### Dust cap HS35

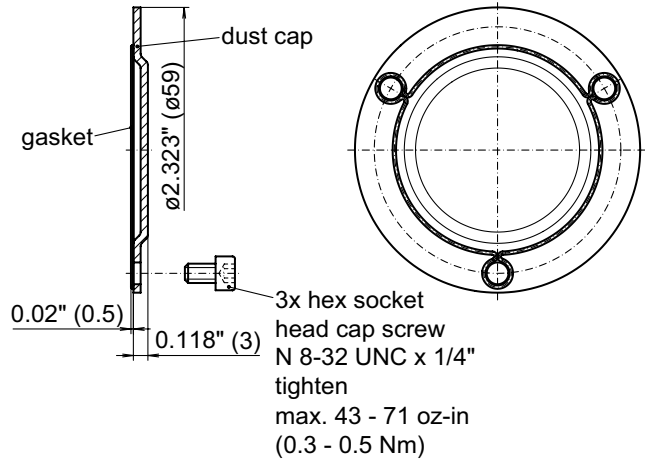

#### Protective cage HS35

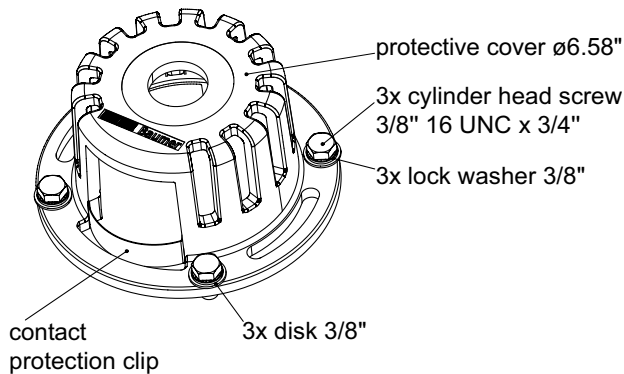

#### Example fitting tether arm

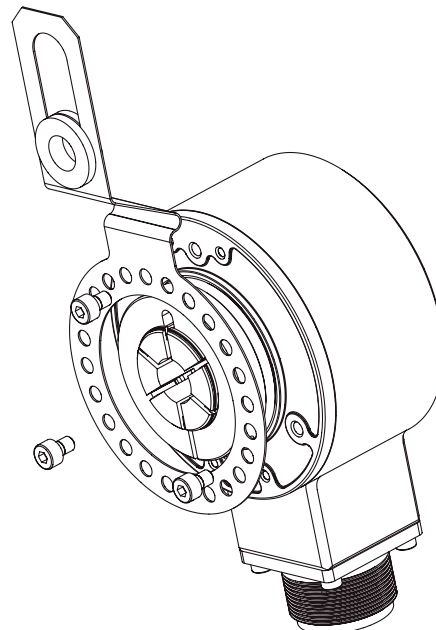

# Incremental encoders

Insulated through hollow shaft  $\varnothing 0.375...1$  inch  
1024...80000 pulses per revolution

HS35F

## Dimensions

Example fitting dust cap HS35

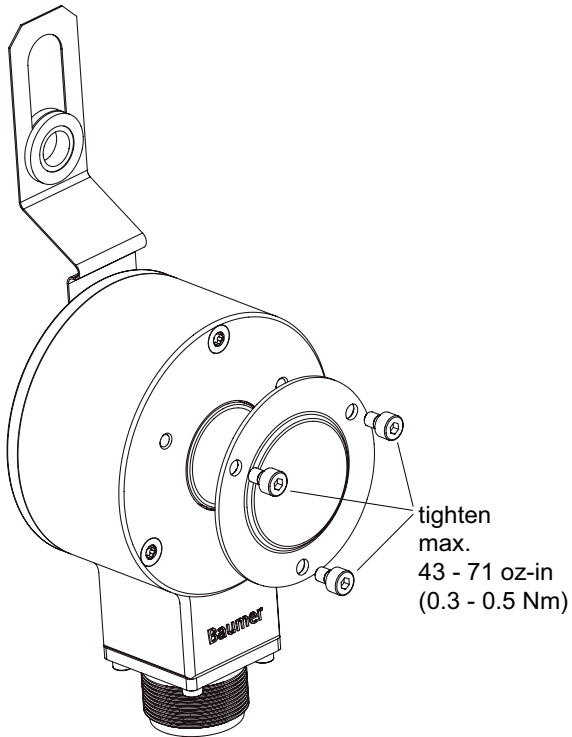

Example fitting protective cover HS35

