

Autonics

PHOTOELECTRIC SENSOR BEN SERIES

MANUAL



Thank you very much for selecting Autonics products.
For your safety, please read the following before using.

Caution for your safety

※Please keep these instructions and review them before using this unit.

※Please observe the cautions that follow;

Warning Serious injury may result if instructions are not followed.

Caution Product may be damaged, or injury may result if instructions are not followed.

※The following is an explanation of the symbols used in the operation manual.

Caution: Injury or danger may occur under special conditions.

Warning

- In case of using this unit with machinery(Ex: nuclear power control, medical equipment, ship, vehicle, train, airplane, combustion apparatus, safety device, crime/disaster prevention equipment, etc) which may cause damages to human life or property, it is required to install fail-safe device. It may cause a fire, human injury or damage to property.
- Do not disassemble and modify this unit. Please contact us if it is required. It may cause electric shock or a fire.

Caution

- This unit shall not be used outdoors. It might shorten the life cycle of the product or cause electric shock. Use this product inside only. Do not use the product outdoors or location subject to temperatures or humidity outside.(Ex: rain, dirty, frost, sunlight, condensation, etc.)
- Do not use this unit in place where there is flammable or explosive gas. It may cause a fire or explosion.
- Please observe voltage rated voltage and do not supply AC power. It may shorten the life cycle or damage to the product.
- Do not use this unit beyond rated power and do not supply AC power(at DC power type). It may cause damage to this unit.
- Please check the polarity of power and wrong wiring. It may cause damage to this unit.
- Do not use this unit in place where there is vibration or impact. It may cause damage to this unit.
- In cleaning the unit, do not use water or an oil-based detergent. It may cause electric shock or a fire.

Ordering information

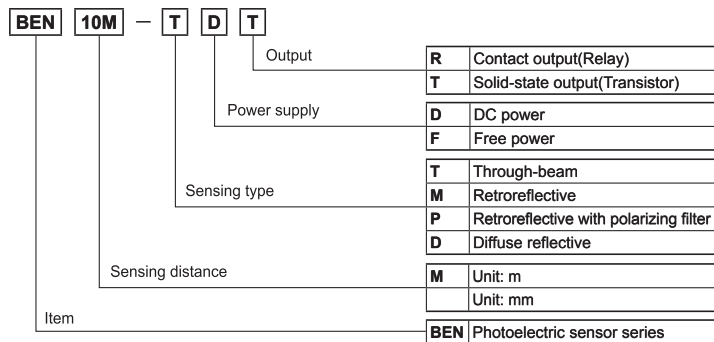

Control output circuit diagram

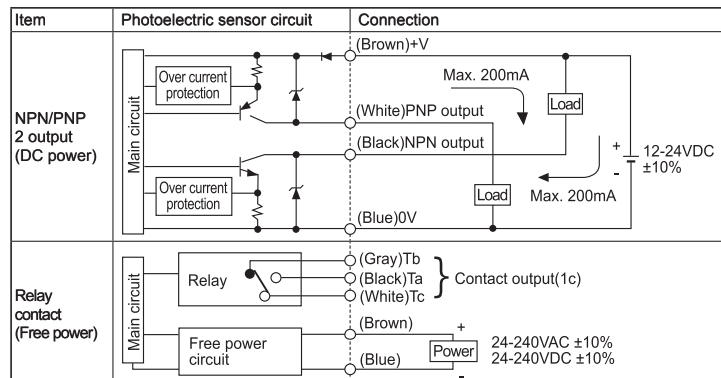

※The above specifications are subject to change and some models may be discontinued without notice.

Dimensions

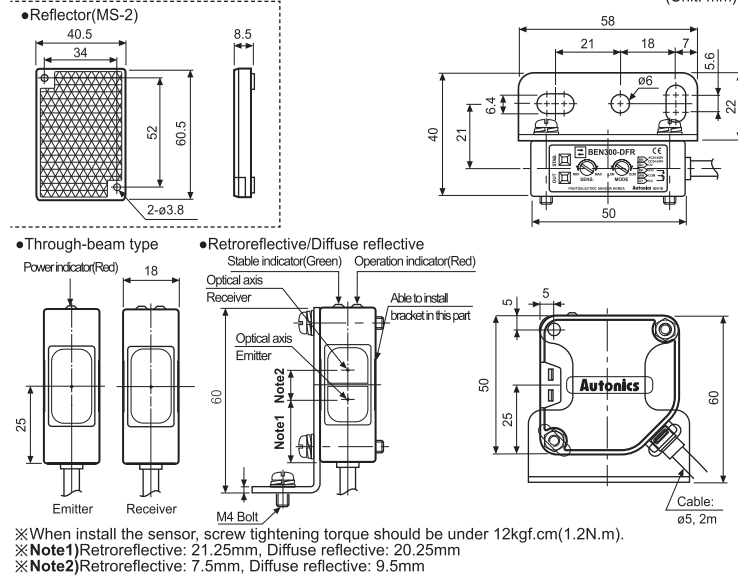

Specifications

Type	Free power, Relay contact output				DC power, Solid state output			
	Through-beam	Retroreflective*1	Retroreflective*1 (with polarizing filter)	Diffuse reflective	Through-beam	Retroreflective*1	Retroreflective*1 (with polarizing filter)	Diffuse reflective
Model	BEN10M-TFR	BEN5M-MFR	BEN3M-PFR	BEN300-DFR	BEN10M-TDT	BEN5M-MDT	BEN3M-PDT	BEN300-DDT
Sensing distance	10m	0.1 to 5m	0.1 to 3m	300mm(100 x 100mm non-glossy white paper)	10m	0.1 to 5m	0.1 to 3m	300mm(100 x 100mm non-glossy white paper)
Sensing target	Opaque materials of Min. φ16mm	Opaque materials of Min. φ60mm	Opaque materials of Min. φ60mm	Translucent, Opaque materials of Max. 20% at sensing distance	Opaque materials of Min. φ16mm	Opaque materials of Min. φ60mm	Opaque materials of Min. φ60mm	Translucent, Opaque materials of Max. 20% at sensing distance
Hysteresis	-	-	-	-	-	-	-	-
Response time	Max. 20ms	-	-	-	Max. 1ms	-	-	-
Power supply	24-240VAC ±10%/50/60Hz, 24-240VDC ±10%(Ripple P-P: Max. 10%)				12-24VDC ±10%(Ripple P-P: Max. 10%)			
Power consumption	Max. 4VA	-	-	-	-	-	-	-
Current consumption	-	-	-	-	Max. 50mA	-	-	-
Light source	Infrared LED(850nm)	-	Red LED(660nm)	Infrared LED(940nm)	Infrared LED(850nm)	-	Red LED(660nm)	Infrared LED(940nm)
Sensitivity adjustment	-	Adjustable VR	-	-	-	Adjustable VR	-	-
Operation mode	Selectable Light ON or Dark ON by VR				Selectable Light ON or Dark ON by VR			
Control output	Relay contact output •Relay contact capacity: 30VDC 3A of resistive load, 250VAC 3A of resistive load •Relay contact composition: 1c				NPN open collector/PNP open collector simultaneous output •Load voltage: Max. 30VDC •Load current: Max. 200mA •Residual voltage - NPN: Max. 1V, PNP: Max. 2.5V			
Relay lifetime	Mechanically: Min. 50,000,000 operation, Electrically: Min. 100,000 operation				-			
Protection circuit	-				Reverse polarity protection, Short-circuit protection			
Light receiving element	Photo IC				Photo IC			
Indication	Operation indicator: Red, Stable indicator: Green(The red lamp on Emitter of through-beam type is for power indication)				Operation indicator: Red, Stable indicator: Green(The red lamp on Emitter of through-beam type is for power indication)			
Insulation resistance	Min. 20MΩ(at 500VDC megger)				Min. 20MΩ(at 500VDC megger)			
Insulation type	Double or strong insulation (Mark: □ Dielectric voltage between the measured input and the power: 1kV)				-			
Noise strength	±1000V the square wave noise(pulse width: 1μs) by the noise simulator				±240V the square wave noise(pulse width: 1μs) by the noise simulator			
Dielectric strength	1000VAC 50/60Hz for 1minute				1000VAC 50/60Hz for 1minute			
Vibration	Mechanical: 1.5mm amplitude at frequency of 10 to 55Hz in each of X, Y, Z directions for 2 hours Malfunction: 1.5mm amplitude at frequency of 10 to 55Hz in each of X, Y, Z directions for 10 minutes				-			
Shock	Mechanical: 500m/s ² (50G) in X, Y, Z directions for 3 times Malfunction: 100m/s ² (10G) in X, Y, Z directions for 3 times				-			
Environment	Ambient illumination: Sunlight: Max. 11,000lx, Incandescent lamp: Max. 3,000lx (Receiver illumination) Ambient temperature: -20 to 65°C(non-freezing condition), Storage: -25 to 70°C Ambient humidity: 35 to 85%RH, Storage: 35 to 85%RH				-			
Protection	IP50(IEC standard)				IP50(IEC standard)			
Material	•Case, Case cover: Heat resistant ABS •Sensing part: PC(with polarizing filter: PMMA)				•Case, Case cover: Heat resistant ABS •Sensing part: PC(with polarizing filter: PMMA)			
Cable	φ5.0mm, 5-wire, Length: 2m(Emitter of through-beam type: φ5.0mm, 2-wire, Length: 2m) (AWG22, Core diameter: 0.08mm, Number of cores: 60, Insulator diameter: φ1.25mm)				φ5.0mm, 4-wire, Length: 2m(Emitter of through-beam type: φ5.0mm, 2-wire, Length: 2m) (AWG22, Core diameter: 0.08mm, Number of cores: 60, Insulator diameter: φ1.25mm)			
Accessory	Individual: -	Common: Reflector(MS-2)	-	-	Individual: -	Common: Reflector(MS-2)	-	-
Approval	-				CE			
Unit weight	Approx. 354g	Approx. 208g	Approx. 195g	Approx. 342g	Approx. 200g	Approx. 187g	Approx. 187g	Approx. 187g

※1: The sensing range and the sensing object of the retroreflective sensor are specified with using the MS-2 reflector. The sensing ranges of the retroreflective sensor in the above table are identified as the possible setting ranges of the MS-2 reflector. The sensor can detect on object under 0.1m apart.
 ※The temperature or humidity mentioned in Environment indicates a non freezing or condensation environment.

Connection

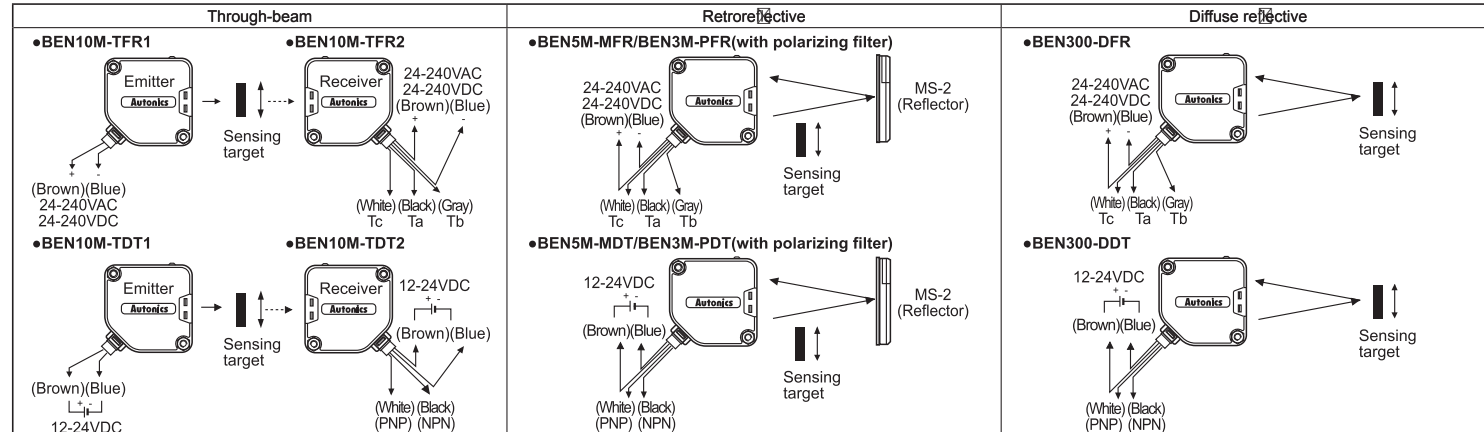

Timing diagram operation

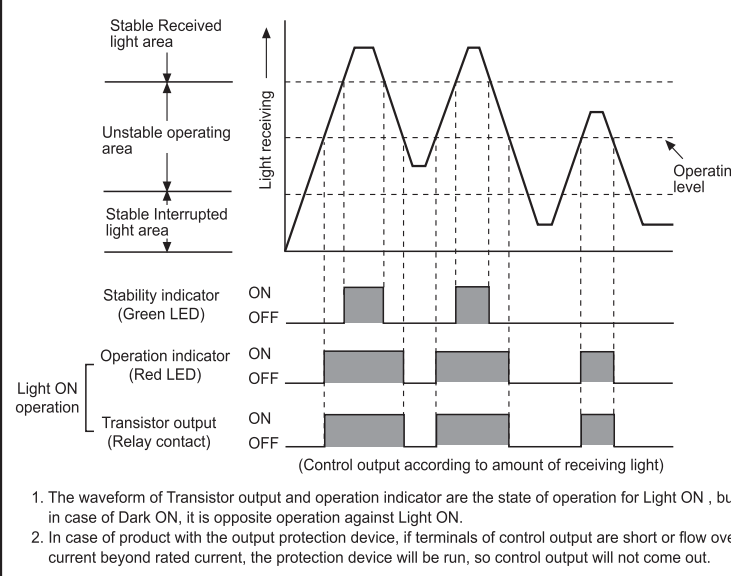

Mounting & Adjustment

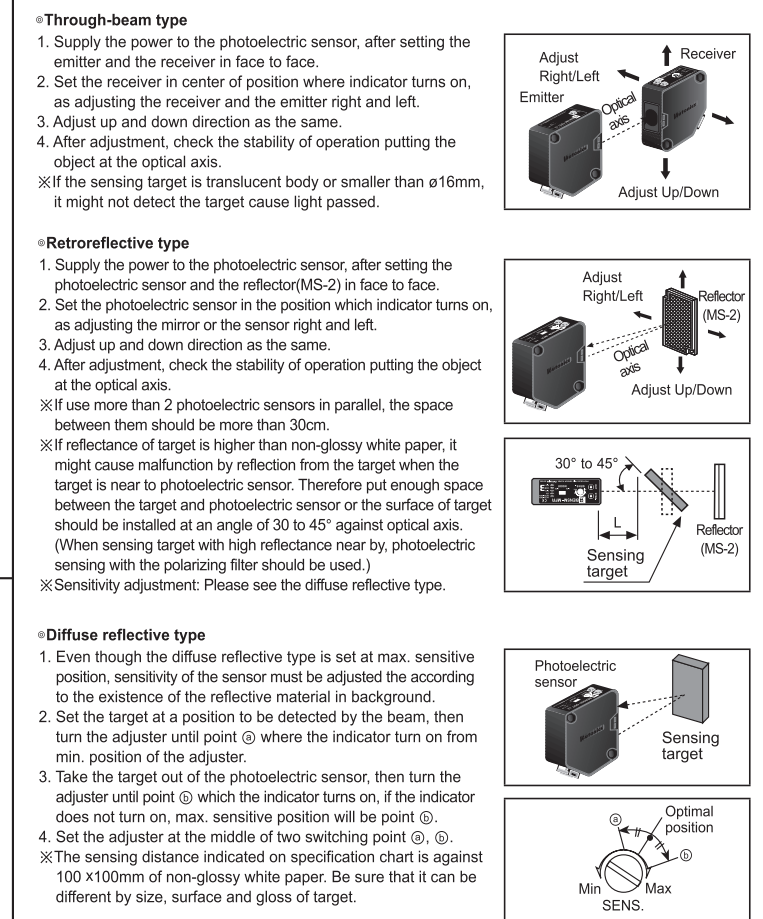

Caution for using

- Intercept a strong source of light as like sunlight, spotlight within inclination angle range of photoelectric sensor.
- The photoelectric sensor may cause malfunction under the fluorescent lamp light, so be sure to use cut-off light with panel.
- When more than 2 sets of Through-beam types sensors are used closely, it might cause interference each other. Be sure to install the emitter and the receiver to shift by each set in order to avoid malfunction.
- When more than 2 sets of diffuse reflection types are installed adjacently, it may cause malfunction by light beam from the other target. So it must be installed at an enough interval.
- If photoelectric sensor is installed at flat part, it might cause malfunction by reflection light from flat part. Be sure to put space between photoelectric sensor and ground.
- When wire the photoelectric sensor with high voltage line, power line in the same conduit, it may cause malfunction or mechanical trouble.
- Therefore please wire separately or use different conduit. Avoid installing the unit as following place. Corrosive gas, oil or dust, strong flux, noise, sunlight, strong alkali, acid.
- In case of connect DC relay as inductive load to output, please remove surges by using diode or varistor.
- The photoelectric sensor cable shall be used as short as possible, if not it may cause malfunction by noise through the cable.
- When it is stained by dirt at lens, please clean the lens with dry cloth, but do not use an organic materials such as alkali, acid, chromic acid.
- When use switching power supply as the source of supplying power, Frame Ground(F.G.) terminal shall be good earth ground and condenser for removing noise shall be installed between 0V and F.G. terminal.

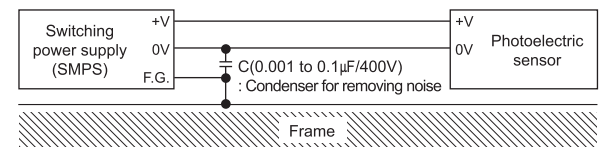

- Installation environment
 - ⊙ It shall be used indoor
 - ⊙ Altitude Max. 2,000m
 - ⊙ Pollution Degree 2
 - ⊙ Installation Category II
- ※It may cause malfunction if above instructions are not followed.

Major products

- Photoelectric sensors
- Fiber optic sensors
- Door sensors
- Door side sensors
- Area sensors
- Proximity sensors
- Pressure sensors
- Rotary encoders
- Connector/Sockets
- Switching mode power supplies
- Control switches/Lamps/Buzzers
- I/O Terminal Blocks & Cables
- Stepper motors/drivers/motion controllers
- Graphic/Logic panels
- Field network devices
- Laser marking system(Fiber, CO₂, Nd:YAG)
- Laser welding/soldering system
- Temperature controllers
- Temperature/Humidity transducers
- SSR/Power controllers
- Counters
- Timers
- Panel meters
- Tachometer/Pulse(Rate)meters
- Display units
- Sensor controllers

Autonics Corporation
<http://www.autonics.com>

Satisfiable Partner For Factory Automation

■ HEAD QUARTERS:
 18, Bansom-ro 513beon-gil, Haeundae-gu, Busan, Korea

■ OVERSEAS SALES:
 #402-404, Bucheon Techno Park, 655, Pyeongcheon-ro, Wonmi-gu, Bucheon, Gyeonggi-do, Korea
 TEL: 82-32-610-2730 / FAX: 82-32-329-0728
 E-mail: sales@autonics.com

EP-KE-08-0250H