

Altech UL489 Busbar System



UL489 recognized
E305318



UL489 Listed Busbars

The Altech Busbar System is an innovative way to jumper up to 57 poles of Miniature Molded Case Circuit Breakers (MMCCB).

The advantages of this busbar system are:

- 30% Installation time savings
- Panel space savings
- Reduced maintenance
- High electrical ratings

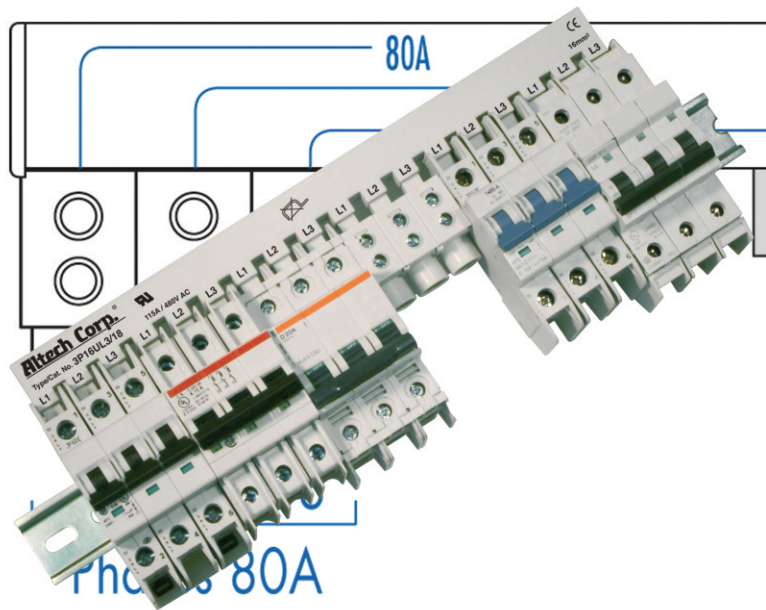

**Universal UL489 Busbar
fits most UL489 Miniature
Circuit Breakers in the market!**

Please contact Altech for details and further information.

UL489 Busbar System

- Every pin configuration is possible by combination of existing 6, 12 and 18 pin busbars.
- Power Feeding:
Power Feed Lug (115A), Direct Power Feed (115A)
- UL listed for Altech's L-Series of Miniature Circuit Breakers
- UL listed for use with most popular UL489 Miniature Circuit Breakers in the market.

Technical Specifications

Material of Busbar

Busbars UL489

Copper

Material of Insulation (Housing)

Polyamide

Electrical Ratings

115A/480VAC

Short Circuit Withstand Rating

10kA

Applying Standards

UL489, VDE0660 Part 100,
IEC60749, DIN EN60947-1

Altech UL489 Busbar System

Power Feed Methods

End Feed Method

P35ULT

With the **P35ULT** Power Feed Lug as a Start/End Feeding Device a maximum input current of **115A per Phase** can be achieved.

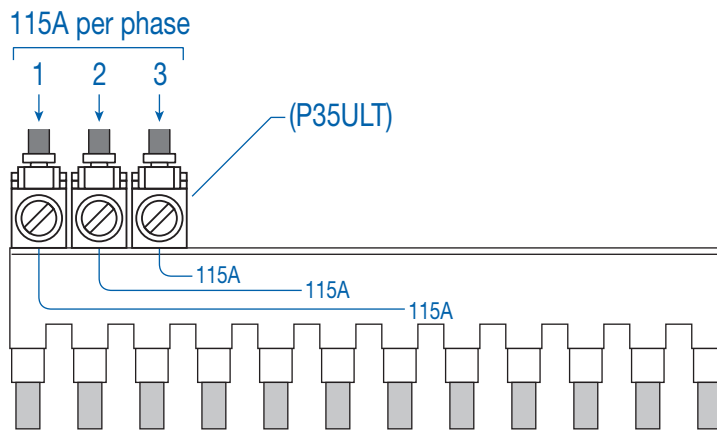

P50ULB

With the **P50ULB** Modular Direct Power Feed as a Start/End Feeding Device a maximum input current of **115A per Phase** can be achieved.

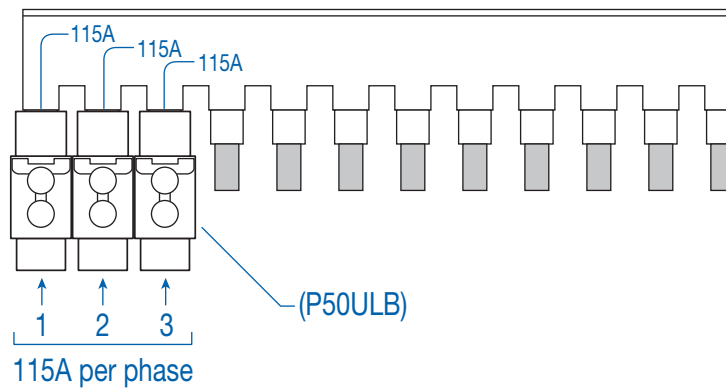

UL 489

UL 508

UL 1077

UL 1077
Equipment Breakers

Earth Leakage
Circuit Breakers

ANNEX

1 PHASE BUSBAR 16mm² for 115A

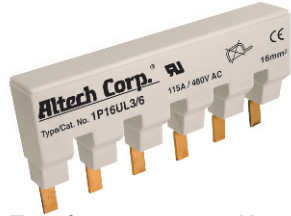

Type/ Cat. No.	No. of Pins	Length [mm]
1P16UL3/6	6	99

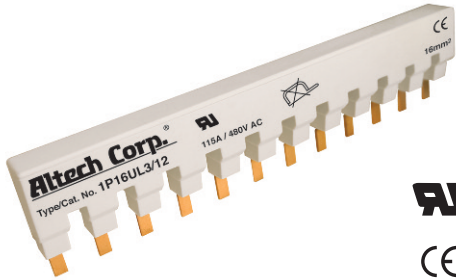
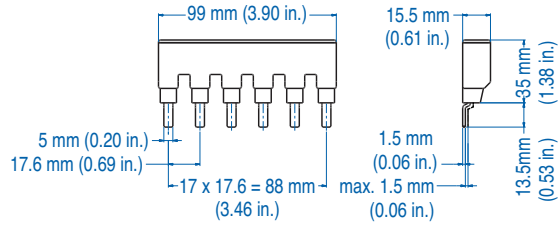

Type/ Cat. No.	No. of Pins	Length [mm]
1P16UL3/12	12	204.6

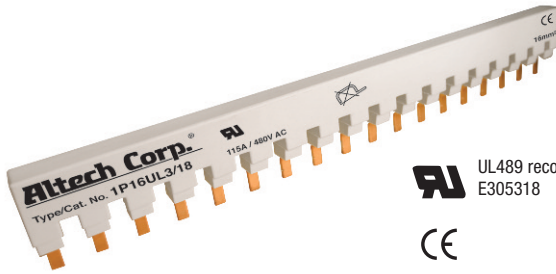
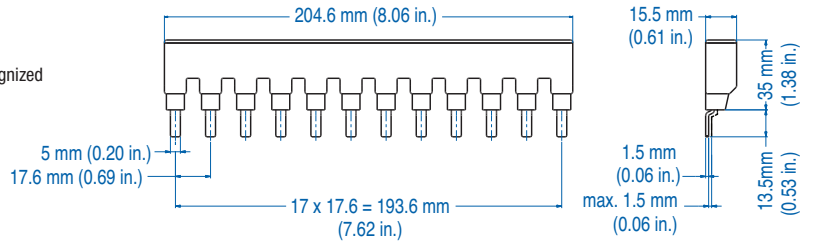

Type/ Cat. No.	No. of Pins	Length [mm]
1P16UL3/18	18	310.2

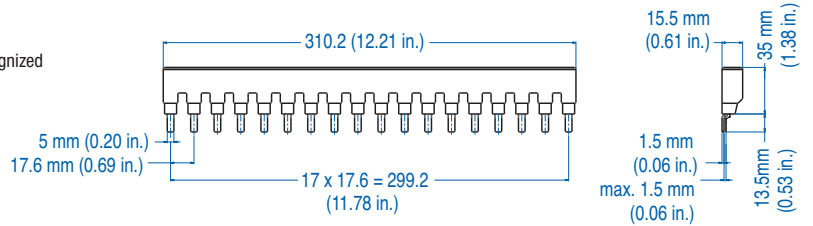

Example for different No. of Pins
eg. 44 pins use 1x 1P16UL3/12 + 2x 1P16UL3/18

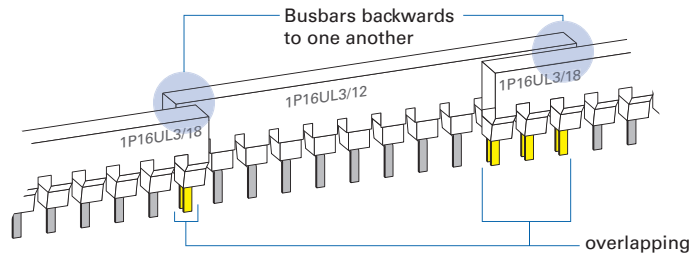

- No. of overlapping pins of 2 busbars must be a multiplier of the No. of phases
- Overlapping busbars are backwards to each other

ACCESSORIES



Type/Cat. No: **P35ULT**
Description: Power Feed Lug

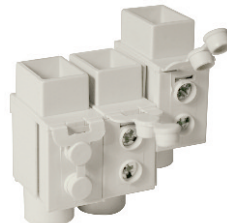

Type/Cat. No: **P50ULB**
Description: Modular Direct Power Feed



Type/Cat. No: **BRUL (3 per strip)**
Description: Insulation Cap

2 PHASE BUSBAR 16mm² for 115A

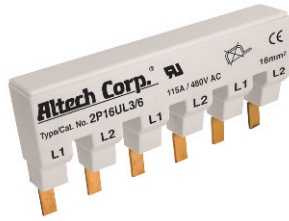

UL489 recognized
E305318
CE

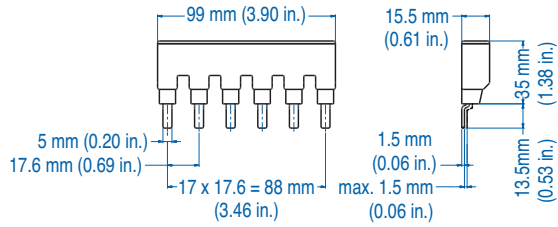

Type/
Cat. No. No. of
Pins Length
[mm]

2P16UL3/6 6 99

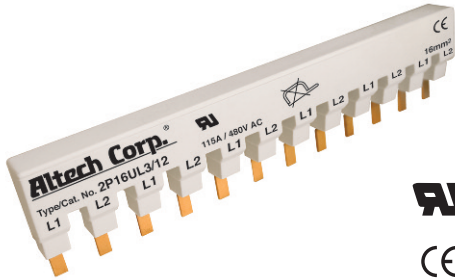

UL489 recognized
E305318
CE

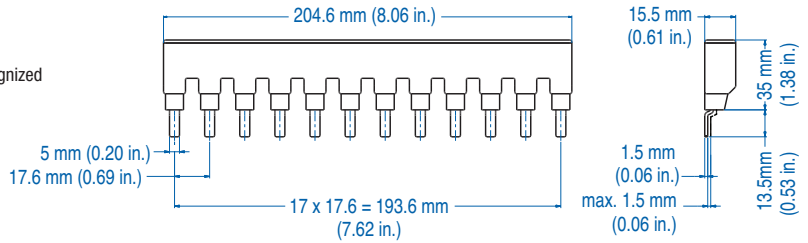

Type/
Cat. No. No. of
Pins Length
[mm]

2P16UL3/12 12 204.6

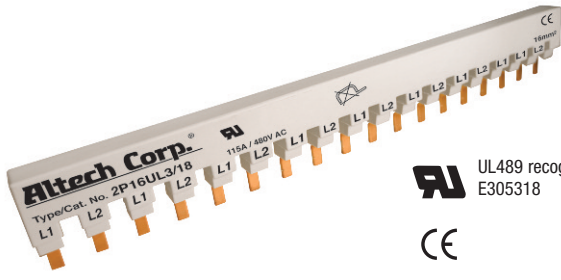

UL489 recognized
E305318
CE

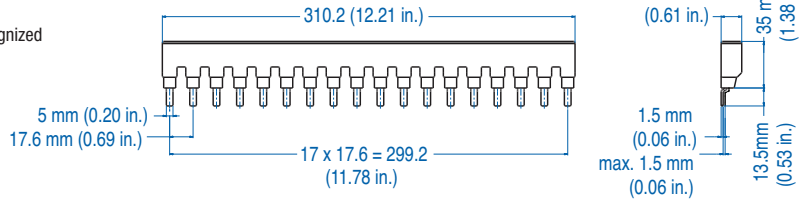

Type/
Cat. No. No. of
Pins Length
[mm]

2P16UL3/18 18 310.2

Example for different No. of Pins
eg. 30 pins use 3x 2P16UL3/12

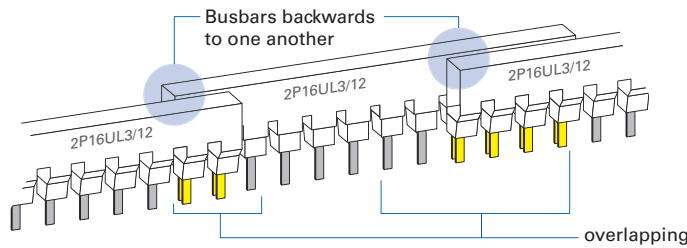

- No. of overlapping pins of 2 busbars must be multiplier of the No. of phases
- Overlapping busbars are backwards to each other

ACCESSORIES



Type/Cat. No.: **P35ULT**
Description: Power Feed Lug

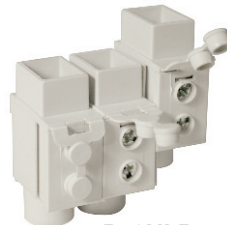

Type/Cat. No.: **P50ULB**
Description: Modular Direct Power Feed



Type/Cat. No.: **BRUL (3 per strip)**
Description: Insulation Cap

UL 489

UL 508

UL 1077

UL 1077
Equipment Breakers

Earth Leakage
Circuit Breakers

ANNEX

3 PHASE BUSBAR 16mm² for 115A

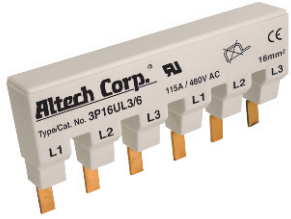

UL489 listed
E305318

Type/ Cat. No.	No. of Pins	Length [mm]
3P16UL3/6	6	99

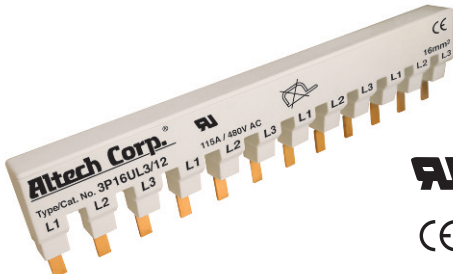
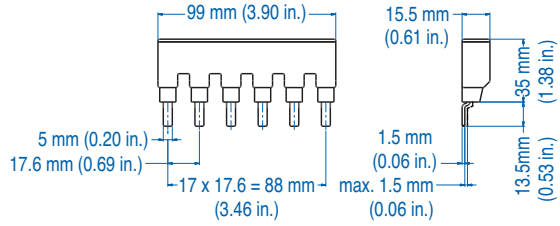

UL489 listed
E305318

Type/ Cat. No.	No. of Pins	Length [mm]
3P16UL3/12	12	204.6

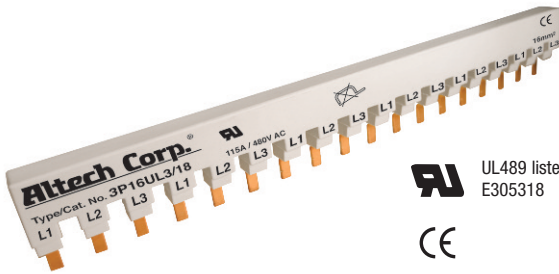
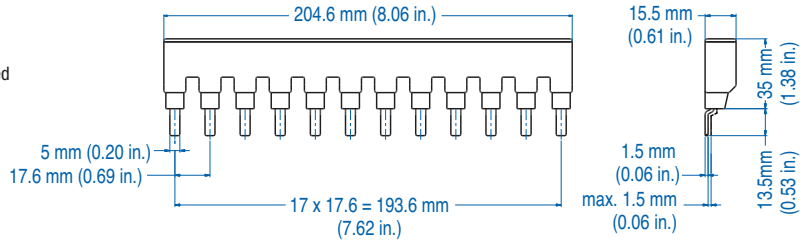

UL489 listed
E305318

Type/ Cat. No.	No. of Pins	Length [mm]
3P16UL3/18	18	310.2

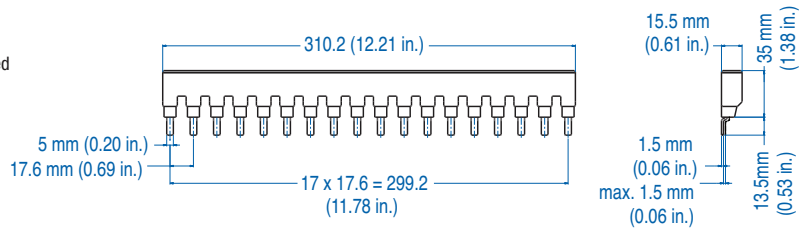

Example for different No. of Pins

eg. 39 pins use 1x 3P16UL3/12 + 2x 3P16UL3/18

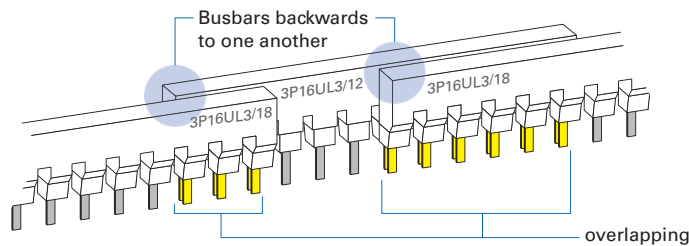

- No. of overlapping pins of 2 busbars must be multiplier of the No. of phases
- Overlapping busbars are backwards to each other

ACCESSORIES



Type/Cat. No: **P35ULT**
Description: Power Feed Lug

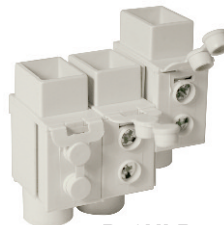

Type/Cat. No: **P50ULB**
Description: Modular Direct Power Feed



Type/Cat. No: **BRUL (3 per strip)**
Description: Insulation Cap

Power Feed Devices

Easy connection of power supply wires to the busbar/MCB. Power Feed Devices ensure permanent connection.

Power Feed Lug



Modular Direct Power Feed

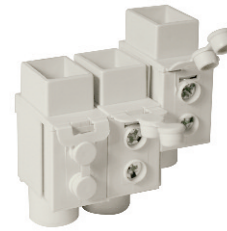

Type/Cat. No.	P35ULT	P50ULB
Electrical Ratings	115A/480V AC	115A/480V AC
Conductors	75 C°	75 C°
Terminal Site Acceptability	14-2AWG (1.5-35mm ²)	14-1AWG (1.5-50mm ²)
Required Torque	4Nm (35.4 lb. in.)	Cable side: 3.5Nm/31 lb. in. (14-6AWG) 4Nm/35.4 lb. in. (4-1AWG) Busbar side: 2.5Nm/22 lb. in.
Material of Lug	Brass	Brass
Insulation Material	Polyamide	Polyamide
For use with	UL489 1-3 phase Busbar	UL489 1-3 phase Busbar

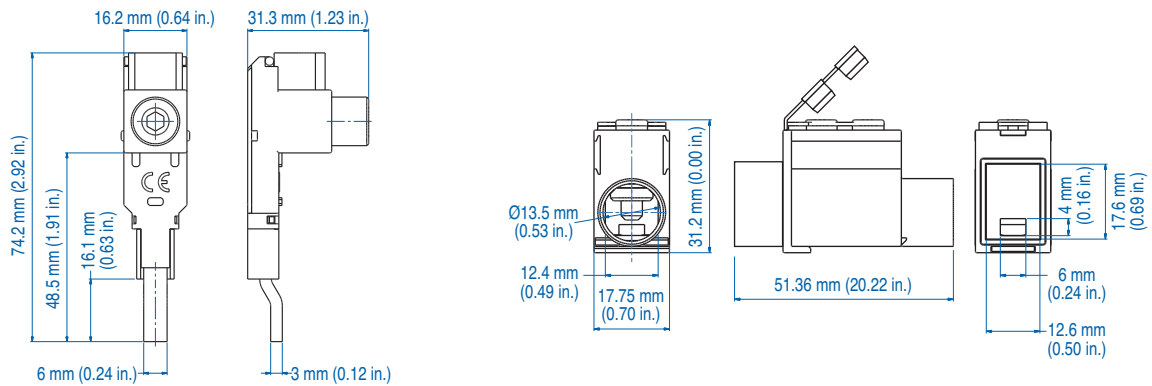

Assembly Instructions

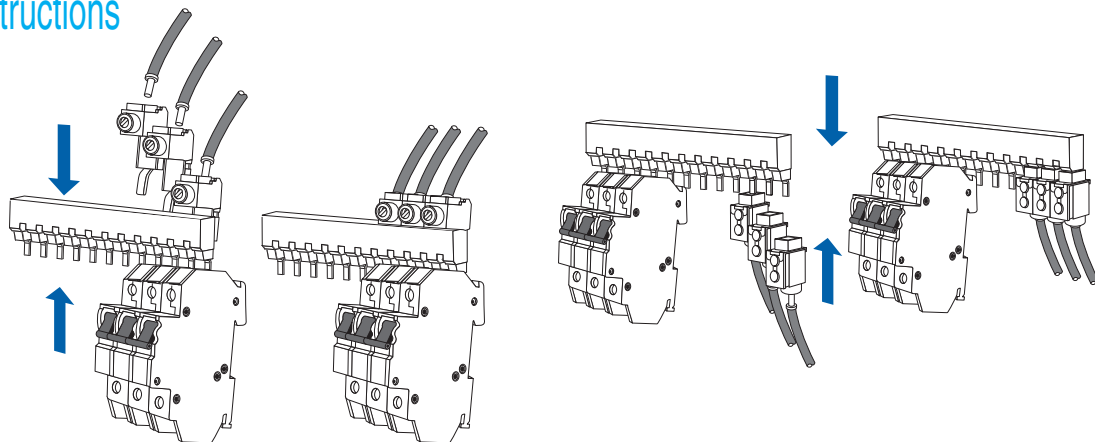

Miscellaneous Accessories

Insulation Caps



Type/Cat. No: **BRUL (3 per strip)**
Description: Insulation Cap

UL 489

UL 508

UL 1077

UL 1077
Equipment Breakers

Earth Leakage
Circuit Breakers

ANNEX

Altech UL489 Busbar Systems

Configuration and Assembly of UL489 Busbars

UL489 Busbars are available in 3 different Pin Configurations per Phase, (6, 12 and 18 Pins).

The UL489 busbar cannot be cut, since the creepage and clearance distance requirements from UL are too stringent. Therefore, to obtain the desired No. of Pins, Busbar-Pins can be overlapped as explained below:

- 1) Busbars are overlapped backwards to each other. Both Pins of each Busbar fit together in the terminals of the Miniature Circuit Breaker.
- 2) The Number of overlapping Pins of 2 Busbar must be a multiplier of the Number of Phases to keep existing Phase sequence. (Can be overlapped by more than the number of phases).
- 3) Any available combination of the 3 different Pin configurations is possible.
- 4) In most cases there is more than 1 combination possible.
- 5) For more possible configurations see Busbar Selection Table on page 21.

Configuration Examples*

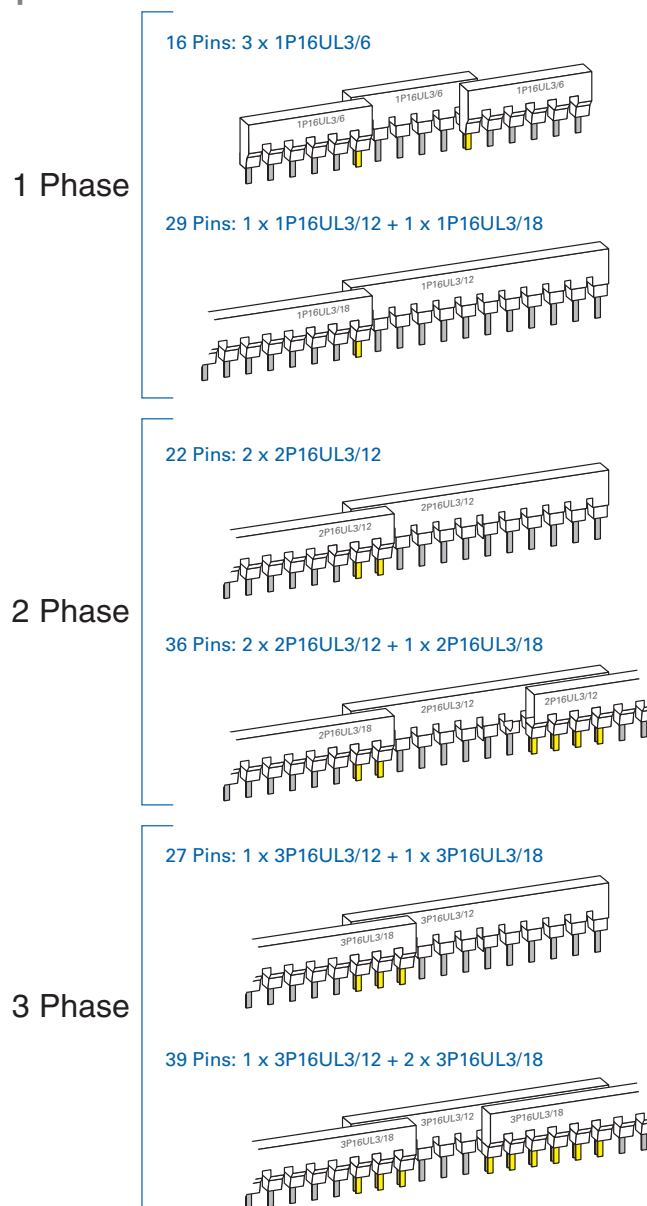

*For Questions, other configurations and detailed information please contact Altech Corp.

Busbar Selection Table

UL 489

UL 508

UL 1077

UL 1077
Equipment Breakers

Earth Leakage
Circuit Breakers

ANNEX

No. of Pins	Necessary Busbars
1 Phase System	
6	1x 1P16UL3/6
7	2x 1P16UL3/6
8	2x 1P16UL3/6
9	2x 1P16UL3/6
10	2x 1P16UL3/6
11	2x 1P16UL3/6
12	1x 1P16UL3/12 3x 1P16UL3/6
13	2x 1P16UL3/12 3x 1P16UL3/6 1x 1P16UL3/6 + 1x 1P16UL3/12
14	2x 1P16UL3/12 3x 1P16UL3/6 1x 1P16UL3/6 + 1x 1P16UL3/12
15	2x 1P16UL3/12 3x 1P16UL3/6 1x 1P16UL3/6 + 1x 1P16UL3/12
16	2x 1P16UL3/12 3x 1P16UL3/6 1x 1P16UL3/6 + 1x 1P16UL3/12
17	2x 1P16UL3/12 1x 1P16UL3/6 + 1x 1P16UL3/12
18	1x 1P16UL3/18 2x 1P16UL3/12 2x 1P16UL3/6 + 1x 1P16UL3/12 1x 1P16UL3/6 + 2x 1P16UL3/12
19	2x 1P16UL3/12 2x 1P16UL3/18 2x 1P16UL3/6 + 1x 1P16UL3/12 1x 1P16UL3/6 + 2x 1P16UL3/12 1x 1P16UL3/6 + 1x 1P16UL3/18 1x 1P16UL3/12 + 1x 1P16UL3/18
20	2x 1P16UL3/12 2x 1P16UL3/18 1x 1P16UL3/6 + 2x 1P16UL3/12 2x 1P16UL3/6 + 1x 1P16UL3/12 1x 1P16UL3/6 + 1x 1P16UL3/18 1x 1P16UL3/12 + 1x 1P16UL3/18
21	2x 1P16UL3/12 2x 1P16UL3/18 2x 1P16UL3/6 + 1x 1P16UL3/12 1x 1P16UL3/6 + 2x 1P16UL3/12 1x 1P16UL3/6 + 1x 1P16UL3/18 1x 1P16UL3/12 + 1x 1P16UL3/18
22	2x 1P16UL3/12 2x 1P16UL3/18 2x 1P16UL3/6 + 1x 1P16UL3/12 1x 1P16UL3/6 + 2x 1P16UL3/12 1x 1P16UL3/6 + 1x 1P16UL3/18 1x 1P16UL3/12 + 1x 1P16UL3/18
23	2x 1P16UL3/12 2x 1P16UL3/18 1x 1P16UL3/6 + 1x 1P16UL3/18 1x 1P16UL3/12 + 1x 1P16UL3/18
24	2x 1P16UL3/12 2x 1P16UL3/18 1x 1P16UL3/12 + 1x 1P16UL3/18 2x 1P16UL3/6 + 1x 1P16UL3/18 3x 1P16UL3/12
25	2x 1P16UL3/12 2x 1P16UL3/18 1x 1P16UL3/12 + 1x 1P16UL3/18 2x 1P16UL3/6 + 1x 1P16UL3/18 3x 1P16UL3/12
26	2x 1P16UL3/18 1x 1P16UL3/12 + 1x 1P16UL3/18 2x 1P16UL3/6 + 1x 1P16UL3/18 3x 1P16UL3/12

No. of Pins	Necessary Busbars
27	2x 1P16UL3/18 1x 1P16UL3/12 + 1x 1P16UL3/18 2x 1P16UL3/6 + 1x 1P16UL3/18 3x 1P16UL3/12
28	2x 1P16UL3/18 1x 1P16UL3/12 + 1x 1P16UL3/18 2x 1P16UL3/6 + 1x 1P16UL3/18 3x 1P16UL3/12
29	2x 1P16UL3/18 1x 1P16UL3/12 + 1x 1P16UL3/18 3x 1P16UL3/12
30	2x 1P16UL3/18 3x 1P16UL3/12 1x 1P16UL3/6 + 1x 1P16UL3/12 + 1x 1P16UL3/18 2x 1P16UL3/12 + 1x 1P16UL3/18 1x 1P16UL3/12 + 2x 1P16UL3/18
31	2x 1P16UL3/18 3x 1P16UL3/12 1x 1P16UL3/6 + 1x 1P16UL3/12 + 1x 1P16UL3/18 2x 1P16UL3/12 + 1x 1P16UL3/18 1x 1P16UL3/12 + 2x 1P16UL3/18
32	2x 1P16UL3/18 3x 1P16UL3/12 1x 1P16UL3/6 + 1x 1P16UL3/12 + 1x 1P16UL3/18 2x 1P16UL3/12 + 1x 1P16UL3/18 1x 1P16UL3/12 + 2x 1P16UL3/18
33	2x 1P16UL3/18 3x 1P16UL3/12 1x 1P16UL3/6 + 1x 1P16UL3/12 + 1x 1P16UL3/18 2x 1P16UL3/12 + 1x 1P16UL3/18 1x 1P16UL3/12 + 2x 1P16UL3/18 1x 1P16UL3/12 + 2x 1P16UL3/18
34	2x 1P16UL3/18 3x 1P16UL3/12 1x 1P16UL3/6 + 1x 1P16UL3/12 + 1x 1P16UL3/18 2x 1P16UL3/12 + 1x 1P16UL3/18 1x 1P16UL3/12 + 2x 1P16UL3/18
35	2x 1P16UL3/18 2x 1P16UL3/12 + 1x 1P16UL3/18 1x 1P16UL3/12 + 2x 1P16UL3/18
36	1x 1P16UL3/6 + 2x 1P16UL3/18 2x 1P16UL3/12 + 1x 1P16UL3/18 3x 1P16UL3/18 1x 1P16UL3/12 + 2x 1P16UL3/18
37	1x 1P16UL3/6 + 2x 1P16UL3/18 2x 1P16UL3/12 + 1x 1P16UL3/18 3x 1P16UL3/18 1x 1P16UL3/12 + 2x 1P16UL3/18
38	1x 1P16UL3/6 + 2x 1P16UL3/18 2x 1P16UL3/12 + 1x 1P16UL3/18 3x 1P16UL3/18 1x 1P16UL3/12 + 2x 1P16UL3/18
39	1x 1P16UL3/6 + 2x 1P16UL3/18 2x 1P16UL3/12 + 1x 1P16UL3/18 3x 1P16UL3/18 1x 1P16UL3/12 + 2x 1P16UL3/18
40	1x 1P16UL3/6 + 2x 1P16UL3/18 2x 1P16UL3/12 + 1x 1P16UL3/18 1x 1P16UL3/12 + 2x 1P16UL3/18 3x 1P16UL3/18
41	1x 1P16UL3/12 + 2x 1P16UL3/18 3x 1P16UL3/18
42	1x 1P16UL3/12 + 2x 1P16UL3/18 3x 1P16UL3/18

No. of Pins	Necessary Busbars
43	1x 1P16UL3/12 + 2x 1P16UL3/18 3x 1P16UL3/18
44	1x 1P16UL3/12 + 2x 1P16UL3/18 3x 1P16UL3/18
45	1x 1P16UL3/12 + 2x 1P16UL3/18 3x 1P16UL3/18
46	1x 1P16UL3/12 + 2x 1P16UL3/18 3x 1P16UL3/18
47	3x 1P16UL3/18
48	3x 1P16UL3/18
49	3x 1P16UL3/18
50	3x 1P16UL3/18
51	3x 1P16UL3/18
52	3x 1P16UL3/18
2 Phase System	
6	1x 2P16UL3/6
8	2x 2P16UL3/6
10	2x 2P16UL3/6
12	3x 2P16UL3/6 1x 2P16UL3/12
14	3x 2P16UL3/6 2x 2P16UL3/12 1x 2P16UL3/6 + 1x 2P16UL3/12
16	2x 2P16UL3/12 1x 2P16UL3/6 + 1x 2P16UL3/12
18	1x 2P16UL3/18 2x 2P16UL3/12 2x 2P16UL3/6 + 1x 2P16UL3/12
20	2x 2P16UL3/6 + 1x 2P16UL3/12 1x 2P16UL3/6 + 1x 2P16UL3/18 2x 2P16UL3/12 2x 2P16UL3/18 1x 2P16UL3/12 + 1x 2P16UL3/18
22	2x 2P16UL3/12 2x 2P16UL3/18 1x 2P16UL3/6 + 1x 2P16UL3/18 1x 2P16UL3/12 + 1x 2P16UL3/18
24	2x 2P16UL3/6 + 1x 2P16UL3/18 1x 2P16UL3/6 + 2x 2P16UL3/12 3x 2P16UL3/12 2x 2P16UL3/18 1x 2P16UL3/12 + 1x 2P16UL3/18
26	2x 2P16UL3/6 + 1x 2P16UL3/18 1x 2P16UL3/6 + 2x 2P16UL3/12 3x 2P16UL3/12 2x 2P16UL3/18 1x 2P16UL3/12 + 1x 2P16UL3/18
28	3x 2P16UL3/12 2x 2P16UL3/18 1x 2P16UL3/12 + 1x 2P16UL3/18
30	1x 2P16UL3/6 + 1x 2P16UL3/12 + 1x 2P16UL3/18 3x 2P16UL3/12 2x 2P16UL3/12 + 1x 2P16UL3/18 2x 2P16UL3/18
32	1x 2P16UL3/6 + 1x 2P16UL3/12 + 1x 2P16UL3/18 3x 2P16UL3/12 2x 2P16UL3/12 + 1x 2P16UL3/18 2x 2P16UL3/18
34	1x 2P16UL3/6 + 1x 2P16UL3/12 + 1x 2P16UL3/18 2x 2P16UL3/12 + 1x 2P16UL3/18 2x 2P16UL3/18
36	1x 2P16UL3/6 + 2x 2P16UL3/18 3x 2P16UL3/18 2x 2P16UL3/12 + 1x 2P16UL3/18 2x 2P16UL3/18

No. of Pins	Necessary Busbars
38	1x 2P16UL3/6 + 2x 2P16UL3/18 3x 2P16UL3/18 2x 2P16UL3/12 + 1x 2P16UL3/18 1x 2P16UL3/12 + 2x 2P16UL3/18
40	3x 2P16UL3/18 1x 2P16UL3/12 + 2x 2P16UL3/18
42	3x 2P16UL3/18 1x 2P16UL3/12 + 2x 2P16UL3/18
44	3x 2P16UL3/18 1x 2P16UL3/12 + 2x 2P16UL3/18
46	3x 2P16UL3/18
48	3x 2P16UL3/18
50	3x 2P16UL3/18
3 Phase System	
9	2x 3P16UL3/6
12	1x 3P16UL3/12 3x 3P16UL3/6
15	1x 3P16UL3/6 + 1x 3P16UL3/12 2x 3P16UL3/12
18	1x 3P16UL3/18 1x 3P16UL3/12 + 2x 3P16UL3/6 2x 3P16UL3/12
21	2x 3P16UL3/12 1x 3P16UL3/6 + 1x 3P16UL3/18 1x 3P16UL3/12 + 1x 3P16UL3/18 2x 3P16UL3/18
24	1x 3P16UL3/12 + 1x 3P16UL3/18 2x 3P16UL3/6 + 1x 3P16UL3/18 1x 3P16UL3/6 + 2x 3P16UL3/12 3x 3P16UL3/12 2x 3P16UL3/18
27	1x 3P16UL3/12 + 1x 3P16UL3/18 2x 3P16UL3/18 3x 3P16UL3/12
30	2x 3P16UL3/18 2x 3P16UL3/12 + 1x 3P16UL3/18 3x 3P16UL3/12 1x 3P16UL3/6 + 1x 3P16UL3/12 + 1x 3P16UL3/18
33	2x 3P16UL3/18 2x 3P16UL3/12 + 1x 3P16UL3/18
36	1x 3P16UL3/6 + 2x 3P16UL3/18 2x 3P16UL3/12 + 1x 3P16UL3/18 1x 3P16UL3/12 + 2x 3P16UL3/18 3x 3P16UL3/18
39	1x 3P16UL3/12 + 2x 3P16UL3/18 3x 3P16UL3/18
42	1x 3P16UL3/12 + 2x 3P16UL3/18 3x 3P16UL3/18
45	3x 3P16UL3/18
48	3x 3P16UL3/18

Note: For detailed information and examples see page 20.