

# FRENIC-ECO



## General Specifications

Standard specifications

1) 208V series (1 to 125HP)

Item		Specifications																
Type (FRN□□□F1S-2U)		001	002	003	005	007	010	015	020	025	030	040	050	060	075	100	125	
Nominal applied motor for three phase input *1 [HP]		1	2	3	5	7.5	10	15	20	25	30	40	50	60	75	100	125	
Nominal applied motor for single phase input *1[HP] a)		1/2	1	1.5	2	3	5	5	7.5	10	10	15	20	25	25	30	40	
Output ratings for three phase input	Rated capacity *2 [kVA]	1.6	2.7	3.8	6.0	9.0	11	16	21	27	31	41	51	60	76	98	123	
	Rated voltage *3 [V]	Three-phase, 200V to 240V (With AVR function )										Three-phase, 200V to 230V (With AVR function )						
	Rated current *4 [A]	4.6	7.5	10.6	16.7	25	31	47	60	75	88	114	143	169	211	273	343	
	Overload capability	120% of rated current for 1min																
	Rated frequency	50, 60Hz																
Input ratings for three phase input	Main power supply	Three-phase,200 to 240V, 50/60Hz										Three-phase, 200 to 220V / 50Hz, 200 to 230V / 60Hz						
	Auxiliary control power input	Single-phase,200 to 240V, 50/60Hz										Single-phase, 200 to 220V / 50Hz, 200 to 230V / 60Hz <sup>a)</sup>						
	Auxiliary fan power input *5	None										Single-phase, 200 to 220V / 50Hz, 200 to 230V / 60Hz						
	Voltage/frequency variations	Voltage: +10 to -15% (Voltage unbalance: 2% or less <sup>9)</sup> ), Frequency: +5 to -5%																
	Rated current *6 [A]	with DCR	3.1	5.8	8.7	14.5	20.6	27.5	41.3	55.1	68.8	82.6	109	134	160	199	270	333
		without DCR	5.1	9.1	12.9	21.5	30.8	40.8	59.4	76.6	94.0	110	144	179	215	—	—	—
Required power supply capacity *7 [kVA]		1.2	2.1 <sup>a)</sup>	3.2	5.3	7.5	10	15	20	25	30	40	49	58	72	98	120	
Output ratings for single phase input <sup>a)</sup>	Rated capacity *2 [kVA]	0.8	1.6	2.3	3.3	3.9	6.1	7.5 <sup>b)</sup>	8.6	11	13 <sup>b)</sup>	16	21	27	27	34	41	
	Rated current *4 [A]	2.4	4.6	6.6	9.3	11	17	21 <sup>b)</sup>	24	31	37 <sup>b)</sup>	46.2	59.4	75	76 <sup>b)</sup>	95	114	
Input ratings for single phase input <sup>a)</sup>	Main power supply	Single-phase,200 to 240V, 50/60Hz										Single-phase, 200 to 220V / 50Hz, 200 to 230V / 60Hz						
	Auxiliary control power input	Single-phase,200 to 240V, 50/60Hz										Single-phase, 200 to 220V / 50Hz, 200 to 230V / 60Hz						
	Auxiliary fan power input *5	None										Single-phase, 200 to 220V / 50Hz, 200 to 230V / 60Hz						
	Voltage/frequency variations	Voltage: +10 to -10%, Frequency: +5 to -5%																
	Rated current *6 [A]	with DCR	3.4	6.3	9.2	16.7	24.5	31.6	40.9	53.6	65.6	77.6	109	138	165	169	215	272
		without DCR	5.1	9.1	12.9	21.5	30.8	40.8	59.4	76.6	94.0	110	144	179	215	---	---	---
Required power supply capacity *7 [kVA]		0.8	1.4	2.0	3.5	5.1	6.6	8.6	12	14	17	23	29	35	36	45	57	
Braking	Torque *8 [%]	20										10 to 15						
	DC injection braking	Starting frequency: 0.0 to 60.0Hz, Braking time: 0.0 to 30.0s, Braking level: 0 to 60%																
DC reactor (DCR)	Option															Standard		
EMC Filter	Option																	
KEY PAD	Multifunctional Keypad (TP-G1W)																	
Applicable safety standards	UL508C, C22.2 No.14, EN50178:1997															UL508C C22.2 No.14		
Enclosure(IEC60529)	IP20 / UL open type										IP00 / UL open type							
Cooling method	Natural cooling	Fan cooling																
Mass [lbs(kg)]		7.1	7.3	7.3	7.5	13	13	15	21	21	25	51	73	75	90	90	265	
		(3.2)	(3.3)	(3.3)	(3.4)	(5.8)	(6.0)	(6.9)	(9.7)	(9.7)	(11.5)	(23)	(33)	(34)	(41)	(41)	(120)	

Note:

\*1 Standard 4-pole motor

\*2 Rated capacity is calculated by assuming the output rated voltage as 208V for three-phase input and single-phase input. <sup>a)</sup>

\*3 Output voltage cannot exceed the power supply voltage.

\*4 An excessively low setting of the carrier frequency may result in the higher motor temperature or tripping of the inverter by its overcurrent limiter setting. Lower the continuous load or maximum load instead. (When setting the carrier frequency (F26) to 1kHz, reduce the load to 80% of its rating.)

\*5 Use [R1,T1] terminals for driving AC cooling fans of an inverter powered by the DC link bus, such as by a high power factor PWM converter. (In ordinary operation, the terminals are not used.)

\*6 Calculated under Fuji-specified conditions.

\*7 Obtained when a DC reactor (DCR) is used.

\*8 Average braking torque (Varies with the efficiency of the motor.)

\*9 
$$\text{Voltage unbalance} = \frac{\text{Max. voltage [V]} - \text{Min. voltage [V]}}{\text{Three - phase average voltage [V]}} \times 67 \quad (\text{IEC61800 - 3(5.2.3)})$$

If this value is 2 to 3%, use an AC reactor (ACR).

a) When utilized on a single phase application the drive's output voltage may be lower than the nominal rated voltage

## 2) 460V series (1 to 75HP)

I t e m		Specifications															
Type (FRN□□□F1S-4U)		001	002	003	005	007	010	015	020	025	030	040	050	060	075		
Nominal applied motor for three phase input <sup>*1</sup> [HP]		1	2	3	5	7.5	10	15	20	25	30	40	50	60	75		
Nominal applied motor for single phase input <sup>*1</sup> [HP] <sup>a)</sup>		1/4	1	1	2	3	3	7.5	7.5	10	10	15	20	20	30		
Output ratings for three phase input	Rated capacity <sup>*2</sup> [kVA]	1.9	2.9	4.3	7.1	9.9	13	18	23	29	35	47	57	67	83		
	Rated voltage <sup>*3</sup> [V]	Three-phase, 380V to 480V (With AVR function )															
	Rated current <sup>*4</sup> [A]	2.5	3.7	5.5	9.0	12.5	16.5	23	30	37	44	59	72	85	105		
	Overload capability	120% of rated current for 1min															
	Rated frequency	50, 60Hz															
Input ratings for three phase input	Main power supply	Three-phase, 380 to 480V, 50/60Hz											Three-phase, 380 to 440V / 50Hz, 380 to 480V / 60Hz				
	Auxiliary control power input	Single-phase, 380 to 480V, 50/60Hz											Single-phase, <sup>a)</sup> 380 to 440V / 50Hz, 380 to 480V / 60Hz				
	Auxiliary fan power input <sup>*5</sup>	None											Single-phase, 380 to 440V / 50Hz, 380 to 480V / 60Hz				
	Voltage/frequency variations	Voltage: +10 to -15% (Voltage unbalance: 2% or less <sup>*9</sup> ), Frequency: +5 to -5%															
	Rated current <sup>*6</sup> [A]	with DCR	1.3	2.5	3.8	6.2	8.9	11.8	17.7	23.7	29.6	35.5	46.8	57.0	68.4	85.7	
		without DCR	2.5	4.8	6.9	10.8	14.5	19.1	27.7	36.0	43.6	50.9	64.0	78.5	93.7	118	
Required power supply capacity <sup>*7</sup> [kVA]		1.1	2.0	3.1	5.0	7.1	9.5 <sup>a)</sup>	15	19	24	29	38	46	55	69		
Output ratings for single phase input <sup>a)</sup>	Rated capacity <sup>*2</sup> [kVA]	0.9	1.6	2.1	2.9	4.6	6.2	9.5	10	12	15	18	23	27	34		
	Rated current <sup>*4</sup> [A]	1.2	2.1	2.7	3.7	5.8	7.9	12	13	16	19	23	30	35	43		
Input ratings for single phase input <sup>a)</sup>	Main power supply	Single-phase, 380 to 480V, 50/60Hz											Single-phase, 380 to 440V / 50Hz, 380 to 480V / 60Hz				
	Auxiliary control power input	Single-phase, 380 to 480V, 50/60Hz											Single-phase, 380 to 440V / 50Hz, 380 to 480V / 60Hz				
	Auxiliary fan power input <sup>*5</sup>	None											Single-phase, 380 to 440V / 50Hz, 380 to 480V / 60Hz				
	Voltage/frequency variations	Voltage: +10 to -10%, Frequency: +5 to -5%															
	Rated current <sup>*6</sup> [A]	with DCR	1.5	2.9	4.1	6.2	9.5	12.9	20.1	23.5	28.8	34.9	43.9	57.6	69.3	85.2	
		without DCR	2.5	4.8	6.9	10.8	14.5	19.1	27.7	36.0	43.6	50.9	64.0	78.5	93.7	115	
Required power supply capacity <sup>*7</sup> [kVA]		0.7	1.4	1.9	2.9	4.4	6.0	9.3	11	14	17	21	27	32	40		
Braking	Torque <sup>*8</sup> [%]	20										10 to 15					
	DC injection braking	Starting frequency: 0.0 to 60.0Hz, Braking time: 0.0 to 30.0s, Braking level: 0 to 60%															
DC reactor (DCR)	Option																
EMC Filter	Option																
KEY PAD	Multifunctional Keypad (TP-G1W)																
Applicable safety standards	UL508C, C22.2 No.14, EN50178:1997																
Enclosure(IEC60529)	IP20 / UL open type										IP00 / UL open type						
Cooling method	Natural cooling				Fan cooling												
Mass [lbs(kg)]	6.8 (3.1)	7.1 (3.2)	7.3 (3.3)	7.5 (3.4)	7.5 (3.4)	13 (6.0)	13 (6.0)	15 (6.9)	22 (9.9)	22 (9.9)	25 (11.5)	51 (23)	53 (24)	73 (33)			

Note:

\*1 Standard 4-pole motor

\*2 Rated capacity is calculated by assuming the output rated voltage as 460V for three-phase input and single-phase-input. <sup>a)</sup>

\*3 Output voltage cannot exceed the power supply voltage.

\*4 An excessively low setting of the carrier frequency may result in the higher motor temperature or tripping of the inverter by its overcurrent limiter setting. Lower the continuous load or maximum load instead. (When setting the carrier frequency (F26) to 1kHz, reduce the load to 80% of its rating.)

\*5 Use [R1,T1] terminals for driving AC cooling fans of an inverter powered by the DC link bus, such as by a high power factor PWM converter. (In ordinary operation, the terminals are not used.)

\*6 Calculated under Fuji-specified conditions.

\*7 Obtained when a DC reactor (DCR) is used.

\*8 Average braking torque (Varies with the efficiency of the motor.)

\*9 
$$\text{Voltage unbalance} = \frac{\text{Max. voltage [V]} - \text{Min. voltage [V]}}{\text{Three - phase average voltage [V]}} \times 67 \quad (\text{IEC61800} - 3(5.2.3))$$

If this value is 2 to 3%, use an AC reactor (ACR).

a) When utilized on a single phase application the drive's output voltage may be lower than the nominal rated voltage

### 3) 460V series (100 to 900HP)

I t e m		Specifications															
Type (FRN□□□F1S-4U)		100	125	150	200	250	300	350	400	450	500	600	700	800	900		
Nominal applied motor for three phase input *1 [HP]		100	125	150	200	250	300	350	400	450	500	600	700	800	900		
Nominal applied motor for single phase input *1 [HP] <sup>a)</sup>		30	40	50	60	75	100	100	125	125	150	200	200	250	250		
Output ratings for three phase input	Rated capacity *2 [kVA]	110	133	161	191	240	286	330	380	414	517	589	669	764	828		
	Rated voltage *3 [V]	Three-phase, 380V to 480V (With AVR function )															
	Rated current *4 [A]	139	168	203	240	302	360	415	477	520	650	740	840	960	1040		
	Overload capability	120% of rated current for 1min															
	Rated frequency	50, 60Hz															
Input ratings for three phase input	Main power supply	Three-phase, 380 to 440V / 50Hz, 380 to 480V / 60Hz															
	Auxiliary control power input	Single-phase, 380 to 440V / 50Hz, 380 to 480V / 60Hz <sup>a)</sup>															
	Auxiliary fan power input *5	Single-phase, 380 to 440V / 50Hz, 380 to 480V / 60Hz															
	Voltage/frequency variations	Voltage: +10 to -15% (Voltage unbalance: 2% or less <sup>9)</sup> ), Frequency: +5 to -5%															
	Rated current *6 [A]	with DCR	113	140	169	222	275	330	382	440	495	545	652	756	869	981	
		without DCR	—	—	—	—	—	—	—	—	—	—	—	—	—	—	
Required power supply capacity *7 [kVA]		91	112	135	177	220	263	305	351	395	435	520	603	693	782		
Output ratings for single phase input <sup>a)</sup>	Rated capacity *2 [kVA]	40	50	60	73	78	107	129	136	160	195	228	263	309	327		
	Rated current *4 [A]	51	63	76	92	98	135	162	171	202	246	287	331	388	411		
Input ratings for single phase input <sup>a)</sup>	Main power supply	Single-phase, 380 to 440V / 50Hz, 380 to 480V / 60Hz															
	Auxiliary control power input	Single-phase, 380 to 440V / 50Hz, 380 to 480V / 60Hz															
	Auxiliary fan power input *5	Single-phase, 380 to 440V / 50Hz, 380 to 480V / 60Hz															
	Voltage/frequency variations	Voltage: +10 to -10%, Frequency: +5 to -5%															
	Rated current *6 [A]	with DCR	102	125	151	180	231	271	311	363	392	482	560	636	714	782	
		without DCR	---	---	---	---	---	---	---	---	---	---	---	---	---	---	
Required power supply capacity *7 [kVA]		47	58	70	83	107	125	144	167	181	222	258	293	329	360		
Braking	Torque *8 [%]	10 to 15															
	DC injection braking	Starting frequency: 0.0 to 60.0Hz, Braking time: 0.0 to 30.0s, Braking level: 0 to 60%															
DC reactor (DCR)	Standard (External)																
EMC Filter	Option																
KEY PAD	Multifunctional Keypad (TP-G1W)																
Applicable safety standards	UL508C, C22.2 No.14, EN50178:1997							UL508C, C22.2 No.14									
Enclosure(IEC60529)	IP00 / UL open type																
Cooling method	Fan cooling																
Mass [lbs(kg)]		75	93	99	139	212	212	216	357	357	529	529	783	794	794		
		(34)	(42)	(45)	(63)	(96)	(96)	(98)	(162)	(162)	(240)	(240)	(355)	(360)	(360)		

Note:

\*1 Standard 4-pole motor

\*2 Rated capacity is calculated by assuming the output rated voltage as 460V for three-phase input and single-phase input.<sup>a)</sup>

\*3 Output voltage cannot exceed the power supply voltage.

\*4 An excessively low setting of the carrier frequency may result in the higher motor temperature or tripping of the inverter by its overcurrent limiter setting. Lower the continuous load or maximum load instead. (When setting the carrier frequency (F26) to 1kHz, reduce the load to 80% of its rating.)

\*5 Use [R1,T1] terminals for driving AC cooling fans of an inverter powered by the DC link bus, such as by a high power factor PWM converter. (In ordinary operation, the terminals are not used.)

\*6 Calculated under Fuji-specified conditions.

\*7 Obtained when a DC reactor (DCR) is used.

\*8 Average braking torque (Varies with the efficiency of the motor.)

\*9 
$$\text{Voltage unbalance} = \frac{\text{Max. voltage [V]} - \text{Mn. voltage [V]}}{\text{Three - phase average voltage [V]}} \times 67 \quad (\text{IEC61800} - 3(5.2.3))$$

If this value is 2 to 3%, use an AC reactor (ACR).

a) When utilized on a single phase application the drive's output voltage may be lower than the nominal rated voltage

## 2. Common specifications

Item		Explanation	Remarks
Output frequency	Setting range	Maximum frequency	25 to 120Hz
		Base frequency	25 to 120Hz
		Starting frequency	0.1 to 60.0Hz
		Carrier frequency	<ul style="list-style-type: none"> <li>• 0.75 to 15kHz (208V/460V: 1 to 25HP for 208V and 1 to 30HP for 460V)</li> <li>• 0.75 to 10kHz (208V/460V: 30 to 100HP for 208V and 40HP to 100HP for 460V)</li> <li>• 0.75 to 6kHz (208V/460V: 125HP for 208V and 125 to 900HP for 460V)</li> </ul> The carrier frequency may drop automatically according to the ambient temperature or output current to protect the inverter. This protective operation can be canceled by function code H98.
	Accuracy (Stability)	<ul style="list-style-type: none"> <li>• Analog setting: <math>\pm 0.2\%</math> of maximum frequency (at <math>25 \pm 10^\circ\text{C}</math> (<math>77 \pm 50^\circ\text{F}</math>))</li> <li>• Keypad setting: <math>\pm 0.01\%</math> of maximum frequency (at <math>-10</math> to <math>+50^\circ\text{C}</math> (<math>14</math> to <math>122^\circ\text{F}</math>))</li> </ul>	
Setting resolution	<ul style="list-style-type: none"> <li>• Analog setting: 1/1000 of maximum frequency (ex. 0.06Hz at 60Hz, 0.12Hz at 120Hz)</li> <li>• Keypad setting: 0.01Hz (99.99Hz or less), 0.1Hz (100.0Hz or more)</li> <li>• Link setting: Selectable from 2 types-                             <ul style="list-style-type: none"> <li>• 1/20000 of maximum frequency (ex. 0.003Hz at 60Hz, 0.006Hz at 120Hz)</li> <li>• 0.01Hz (fixed)</li> </ul> </li> </ul>		
Control	Control method	V/f control	
	Voltage/freq. characteristic	Possible to set output voltage at base frequency and at maximum output frequency (common spec.). AVR control can be turned ON or OFF. Three-phase 208V: 80 to 240V Three-phase 460V: 160 to 500V	
	(Non-linear V/f setting)	1 point (Arbitrary voltage and frequency can be set.) Three-phase 208V: 0 to 240V/0 to 120Hz Three-phase 460V: 0 to 500V/0 to 120Hz	
	Torque boost (Load selection)	Automatic torque boost (for variable torque load with high starting torque ) <ul style="list-style-type: none"> <li>• Manual torque boost                              Torque boost value can be set 0.0 to 20.0 percent.</li> <li>• Selectable by load characteristics                              (Variable torque load with high starting torque and Variable torque load)</li> </ul>	
	Starting torque	50% or over	
	Start/stop	Keypad operation: Start and stop with , $\text{FWD}$ or $\text{REV}$ , and $\text{STOP}$ keys	
		External signals (7 digital inputs): Forward (reverse) rotation, stop command (capable of 3-wire operation), second operation command, coast-to-stop command, external alarm, alarm reset, etc.	
		Link operation: Operation through RS-485 communication and Field Bus communication (option)	
		Operation command switch: Remote/local switch, link switch, second operation command switch	
	Frequency setting	Keypad operation: Can be set with $\text{UP}$ , $\text{DOWN}$ key.	
External potentiometer: Can be set with the external resistor (1 to 5k $\Omega$ , 1/2W)			
Analog input: Can be set with external voltage/current input. 0 to +10VDC (0 to +5VDC) / 0 to 100% (Terminal [12], [V2]) 0 to +5VDC: change (200%) in analog input gain setting. +1 to +5VDC: adjustable with bias/analog input gain +4 to +20mADC / 0 to 100% (Terminal [C1])			
Multistep frequency: Selectable from 8 steps (step 0 to 7)			
UP/DOWN operation: The frequency rises or lowers while the digital input signal is turned on.			
Link operation: Can be set with RS-485 communications and field bus communications (option).			
Frequency setting change: Two types of frequency settings can be switched with an external signal (digital input). Changeover between remote and local (keypad operation) or frequency setup through communication is also possible.			



Item	Explanation	Remarks	
Control	Frequency setting	Auxiliary frequency setting: Inputs at terminal [12], [C1] or [V2] can be added to the main setting as auxiliary frequency settings. Inverse operation: The digital input signal and function code setting sets or switches between the normal and inverse operations. +10 to 0VDC / 0 to 100%(Terminal [12], [V2]) +20 to +4mADC / 0 to 100%(Terminal [C1])	
	Acceleration / Deceleration time	0.00 to 3600s • Acceleration and deceleration pattern can be selected from 4 types: Linear, S-curve (weak), S-curve (strong), Curve (constant output max. capacity). • Shutoff of the operation command coasts the motor to decelerate and stop.	
	Frequency limiter	High and low limiters can be set (setting range: 0 to 120Hz) Selection can be made between continuation of operation and stopping at frequencies equal to or smaller than the lower limit.	
	Bias frequency	Bias of frequency and PID commands can be set in the range between 0 and $\pm 100\%$ .	
	Gain for frequency setting	The analog input gain can be set in the range from 0 to 200%.	
	Jump frequency setting	3 operation points and their common jump hysteresis width (0 to 30Hz) can be set.	
	Restart after momentary power failure	• The inverter restarts upon recovery from power failure without stopping the motor. • In the "operation continuation mode," recovery of the power supply is waited for while the output frequency slightly drops. • Selection can be made among starting at 0Hz, starting at the frequency immediately before the momentary power failure, and starting at a set frequency for the starting method after power recovery.	
	Current limit (Hardware current limiting) (Software current limiting)	Keeps the current under the preset value during operation. • Hardware current limiting is used avoiding overcurrent tripping of the inverter, when impact load change or momentary power failure that can be responded software current limiting. (Hardware current limiting can be inactive.) • Output frequency automatically decreases to keep the output current under the preset value. (Selectable 'At constant speed' and 'During acceleration and at constant speed')	
	Line/inverter switching	• Line/inverter switching (starting at line frequency) can be made with a digital input signal (SW50, SW60). • A built-in line/inverter switching sequence performs sequence control with a digital input signal (ISW50, ISW60) to output a signal (SW88, SW52-1, SW52-2) for controlling an external magnetic contactor (MC). As a built-in sequence, two types can be selected, including the one switching automatically to the line upon an inverter alarm.	
	PID control	Capable of PID regulator control for process Process commands • Key operation (UP and DOWN keys): 0 to 100% • Analog input (terminal [12], [V2]): 0 to +10VDC / 0 to 100% • Analog input (terminal [C1]): +4 to +20mADC / 0 to 100% • UP/DOWN (digital input): 0 to 100% • Communication (RS-485, Bus option): 0 to 20,000 / 0 to 100% Feedback value • Analog input (terminal [12], [V2]): 0 to +10VDC / 0 to 100% • Analog input (terminal [C1]): +4 to +20mADC / 0 to 100% Accessory functions • Alarm output (absolute value alarm, deviation alarm) • Normal operation/inverse operation • Sleep function • PID output limiter • Anti-reset windup function • Integration reset/hold	
	Auto search for idling motor's speed	Operation begins at a preset pick-up frequency to search for the motor speed to start an idling motor without stopping it.	
	Automatic deceleration	Upon a DC link bus voltage exceeding the overvoltage limit level during deceleration, the deceleration time automatically extends to avoid an OV trip.	
	Deceleration characteristic	The motor loss increases during deceleration to reduce the load energy regenerating at the inverter to avoid an OV trip upon mode selection.	
	Automatic energy-saving operation	The output voltage is controlled to minimize the total sum of the motor loss and inverter loss at a constant speed.	
Overload protection control	The output frequency is automatically reduced to suppress the overload protection trip of the inverter caused by an increase in the ambient temperature or motor load, or by other operating conditions.		

	Item	Explanation	Remarks	
Control	Auto-tuning	The motor parameters are automatically tuned.		
	Cooling fan ON/OFF control	Detects inverter internal temperature and stops cooling fan when the temperature is low. An external output can be issued in a transistor or relay output signal.		
	Pump Control	<p>One inverter can control plural pumps. The inverter can control the motors combining inverter driving and commercial power supply driving. The inverter's integral PID controller controls the process value such as flow rate or pressure. Each pump is driven by the inverter or commercial power supply according to changeover signal issued by the inverter. It is possible to select an operation mode from fixed inverter driven motor mode and cyclical inverter driven mode.</p> <p>Fixed inverter driving motor operation: Controlled pumps = inverter driven 1 motor + 4 commercial power supply driven motors.</p> <p>Cyclical inverter driving operation: Controlled pumps = inverter driven / commercial power supply driven 3 motors. (Relay option card OPC-F1-RY is necessary.)</p> <p>The other functions such as scheduled changeover function, running time equalization operation, Pump cumulative running time monitor, cumulative relay on/off count monitor are included.</p>		
	Motor overload memory retention	This is Motor overload memory retention at power up. Both "Electrical thermal overload protection for motor" and "Overload early warning" are retention.		
Indication	Running /stopping	<ul style="list-style-type: none"> <li>• Speed monitor, output current [A], output voltage [V], torque calculation value, input power [kW], PID reference value, PID feedback value, PID output, load factor, motor output</li> <li>• Select the speed monitor to be displayed from the following. Output frequency [Hz], motor speed [r/min.], load shaft speed [r/min.], % indication</li> </ul>		
	Lifetime early warning	The life early warning of the main circuit capacitors, capacitors on the PC boards and the cooling fan can be displayed. An external output is issued in a transistor output signal.		
	Cumulative run time	The cumulative motor running hours, cumulative inverter running hours and cumulative watt-hours can be displayed.		
	Trip mode	<p>Displays the cause of trip by codes.</p> <ul style="list-style-type: none"> <li>• OC1 (Overcurrent during acceleration)</li> <li>• OC2(Overcurrent during deceleration)</li> <li>• OC3(Overcurrent at constant speed)</li> <li>• EF (Grounding fault)</li> <li>• Lin(Input phase loss)</li> <li>• LU(Undervoltage)</li> <li>• OPL(Output phase loss)</li> <li>• OU1(Overvoltage during acceleration)</li> <li>• OU2(Overvoltage during deceleration)</li> <li>• OU3(Overvoltage during constant speed)</li> <li>• OH1(Overheating of the heat sink)</li> <li>• OH2(External alarm)</li> <li>• OH3(Inverter overheat)</li> <li>• OH4(Motor protection (PTC thermistor))</li> <li>• CoF(PID control feedback line disconnection detection protection(Terminal [C1]))</li> </ul>	<ul style="list-style-type: none"> <li>• OL1(Motor overload)</li> <li>• OLU(Inverter overload)</li> <li>• FUS(Blown fuse)</li> <li>• PbF(Charging circuit fault)</li> <li>• Er1(Memory error)</li> <li>• Er2(Keypad communication error)</li> <li>• Er3(CPU error)</li> <li>• Er4(Optional communication error)</li> <li>• Er5(Option error)</li> <li>• Er6(Operation action error)</li> <li>• Er7(Tuning error)</li> <li>• Er8(RS-485 communication error)</li> <li>• ErF(Data save error due to undervoltage)</li> <li>• ErP(RS-485 communication error (option))</li> <li>• ErH(LSI error)</li> </ul>	
	Running or trip mode	Trip history: Saves and displays the last 4 trip codes and their detailed description.		

Item		Explanation	LED indication	
Protection	Overcurrent protection	The inverter is stopped for protection against overcurrent caused by an overload.	OC1 OC2 OC3	
	Short-circuit protection	The inverter is stopped for protection against overcurrent caused by a short circuit in the output circuit.		
	Grounding fault protection	The inverter is stopped only upon start-up for protection against overcurrent caused by a grounding fault in the output circuit. If the power supply is turned on with the grounding fault, the protection may be invalidated. (3-phase 208V 75HP or less, 3-phase 460V 350HP or less)		EF
		The inverter is stopped upon detection of a zero-phase current of the output current and for protection against overcurrent caused by a grounding fault in the output circuit. (3-phase 208V 125HP or more, 3-phase 460V 400HP or more)		
	Overvoltage protection	An excessive voltage (3-phase 208V: 400VDC, 3-phase 460V: 800VDC) in the DC link circuit is detected and the inverter is stopped. If a remarkably large voltage is applied by mistake, the protection cannot be made.	OU1 OU2 OU3	
	Undervoltage	The voltage drop (3-phase 208V: 200VDC, 3-phase 460V: 400VDC) in the DC link circuit is detected to stop the inverter. However, when "F14: 4 or 5" is selected, an alarm is not issued even upon a voltage drop in the DC link circuit.	LU	
	Input phase loss protection	The input phase loss is detected to shut off the inverter output. This function protects the inverter from being broken by adding extreme stress caused by a power phase loss or imbalance between phases. When the load to be connected is small or DC Reactor is connected even in the case of an input phase loss, a phase loss is not detected.	Lin	
	Output phase loss protection	Detects breaks in inverter output wiring at the start of running and during running, stopping the inverter output.	OPL	
	Overheat protection	The temperature of the heat sink in the event of cooling fan trouble and overload is detected to stop the inverter Detects a failure of the internal circulation fan and stops the inverter (For models of 50HP or above in 208V, 75HP or above in 460 V)	OH1	
		The temperature inside the inverter unit in the event of cooling fan trouble and overload is detected to stop the inverter.	OH3	
	Overload protection	The temperature inside the IGBT is calculated from the detection of output current and internal temperature, to shut off the inverter output.	OLU	
	External alarm input	With the digital input signal (THR), the inverter is stopped as for an alarm.	OH2	
	Blown fuse	The wiring breakage of the main circuit fuse in the inverter is detected to stop the inverter. (3-phase 208V 125HP or more, 3-phase 460V 125HP or more)	FUS	
	Abnormal condition in charger circuit	The charging circuit fault in the inverter is detected to stop the inverter. (3-phase 208V 50HP or more, 3-phase 460V 75HP or more)	PbF	
	Motor protection	Electronic thermal overload	The inverter is stopped upon an electronic thermal function setting to protect the motor. • The standard motor is protected in the range of all the frequencies. • The inverter motor is protected in the range of all the frequencies. *The operation level and thermal time constant can be set.	OL1
		PTC thermistor	A PTC thermistor input stops the inverter to protect the motor. • The PTC thermistor is connected between terminals [V2] and [11] to set switches on the control PC board and function codes.	OH4
Overload early warning		Warning signal is output at the predetermined level before stopping the inverter with the electronic thermal function to protect the motor	—	
Memory error	Data is checked upon power-on and data writing to detect any fault in the memory and to stop the inverter if any.	Er1		
Keypad communication error	The multi-function keypad is used to detect a communication fault between the keypad and inverter main body during operation and to stop the inverter if any.	Er2		
CPU error	Detects a CPU error or LSI error caused by noise and so on and stops the inverter.	Er3		
Option communication error	When each option card is used, a fault of communication with the inverter main body is detected to stop the inverter.	Er4		
Option error	When each option card is used, the option side detects a fault to stop the inverter.	Er5		

"—": Not applicable.



Item		Explanation		LED indication
Protection	Operation error	STOP key priority	Pressing the  key on the keypad forcibly decelerates and stops the motor even if the operation command is given through a terminal block or communication. (Er6 will be displayed after stoppage.)	Er6
		Start check	If the operation command is entered in the following cases, Er6 will be displayed on the LED monitor to prohibit operation. <ul style="list-style-type: none"> <li>•Power-on</li> <li>•Alarm reset ( key ON)</li> <li>•The link operation selection "LE" is used to switch operation.</li> </ul>	
	Tuning error	When tuning failure, interruption, or any fault as a result of turning is detected while tuning the motor constant, the inverter is stopped.		Er7
	RS-485 communication error	When the connection port of the keypad is connected via RS-485 communication to the network to detect a communication error, the inverter is stopped to display the error.		Er8
	Data save error upon undervoltage	When the undervoltage protection works, an error is displayed if data cannot be stored.		ErF
	RS-485 communication error	When a RS-485 communication card is used to configure the network, a fault of communication with the inverter main body is detected to stop the inverter.		ErP
	LSI error	When the LSI of power printed circuit board is detected a fault, the inverter stopped. (3 phase 208V 50HP or more, 3-phase 460V 75HP or more)		ErH
	Alarm relay output (for any fault)	The relay signal is output when the inverter stops upon an alarm. <Alarm reset> The  key or digital input signal (RST) is used to reset the alarm stoppage state. <Storage of alarm history and detailed data> Up to the last 4 alarms can be stored and displayed.		—
	Stall prevention	This is protected when the instantaneous overcurrent limitation works. •Instantaneous overcurrent limitation: operates when the inverter output current goes beyond the instantaneous overcurrent limiting level, and avoids tripping (during acceleration and constant speed operation).		—
	Retry function	When the motor is tripped and stopped, this function automatically resets the tripping state and restarts operation. (The number of retries and the length of wait before resetting can be set.)		—
	Surge protection	The inverter is protected against surge voltages intruding across the main circuit power cable and ground.		—
	Command loss detection	A loss (broken wire, etc.) of the frequency command is detected to output an alarm and continue operation at the preset frequency (set at a ratio to the frequency before detection).		—
	Momentary power failure protection	<ul style="list-style-type: none"> <li>• A protective function (inverter stoppage) is activated upon a momentary power failure for 15msec or longer.</li> <li>• If restart upon momentary power failure is selected, the inverter restarts upon recovery of the voltage within the set time.</li> </ul>		—
	PID control feedback line disconnection detection (Terminal [C1])	The inverter is stopped after the time is past over the set value and the input current on the [C1] terminal is less than 2mA under the PID control when [C1] terminal is used as PID control feedback line.		CoF

"—": Not applicable.

Item		Explanation	Remarks
Environment	Installation location	Shall be free from corrosive gases, flammable gases, oil mist, dusts, and direct sunlight. (Pollution degree 2 (IEC60664-1)). Indoor use only.	
	Ambient temperature	-10 to +50°C (14 to 122°F) (-10 to +40°C (14 to 104°F) when inverters are installed side by side without clearance.)	
	Ambient humidity	5 to 95% (no condensation)	
	Altitude	Lower than 3300ft (1000m)	
	Atmospheric pressure	86 to 106kPa	
	Vibration	[100HP or below] 3mm (Max. amplitude) : 2 to less than 9Hz, 9.8m/s <sup>2</sup> : 9 to less than 20Hz 2m/s <sup>2</sup> :20 to less than 55Hz 1m/s <sup>2</sup> :55 to less than 200Hz  [125HP or above] 3mm (Max. amplitude) : 2 to less than 9Hz 2m/s <sup>2</sup> : 9 to less than 55Hz 1m/s <sup>2</sup> :55 to less than 200Hz	
Storage	Ambient temperature	-25 to +70°C (-13 to 158°F)	
	Ambient humidity	5 to 95% (no condensation)	

### 3. Terminal Functions

	Symbol	Terminal name	Functions	Remarks
Main circuit	L1/R, L2/S L3/T	Power input	Connect a three-phase power supply.	
	R0, T0	Auxiliary control power input	Connect a single-phase power supply.	
	R1, T1	Auxiliary power input for the fans	Connect a single-phase power supply. (3-phase 208V 50HP or more, 3-phase 460V 75HP or more)	
	U, V, W	Inverter output	Connect a three-phase motor.	
	P(+), P1	For DC reactor	Connect the DC reactor (DCR).	
	P(+), N(-)	For DC bus connection	Used for DC bus connection.	
	⊖G	Grounding	Terminal for inverter grounding	Two terminals are provided.
Analog input	[13]	Potentiometer power supply	Used for frequency setting device power supply (variable resistance: 1 to 5kΩ)	+10VDC +10mADC max.
	[12]	Voltage input  (Inverse operation) (PID control)  (Frequency aux. setting)  (Analog input monitor)	Used as a frequency setting voltage input. 0 to +10VDC / 0 to 100% (0 to +5VDC / 0 to 100%) +10 to 0VDC / 0 to 100% Used for setting signal (PID process command value) or feedback signal. Used as additional auxiliary setting to various frequency settings. The peripheral analog signal can be displayed on the keypad. (Displaying coefficient: valid)	Input impedance: 22kΩ Maximum input: +15VDC
	[C1]	Current input  (Inverse operation) (PID control)  (Frequency aux. setting)  (Analog input monitor)	Used as a frequency setting current input. +4 to +20mADC / 0 to 100% +20 to +4mADC / 0 to 100% Used for setting signal (PID process command value) or feedback signal. Used as additional auxiliary setting to various frequency settings. The peripheral analog signal can be displayed on the keypad. (Displaying coefficient: valid)	Input impedance: 250Ω Maximum input: +30mADC
	[V2]	Analog setting voltage input (Inverse operation) (PID control)  (For PTC thermistor)  (Frequency aux. setting)  (Analog input monitor)	Used as a frequency setting voltage input. 0 to +10VDC / 0 to 100% (0 to +5VDC / 0 to 100%) +10 to 0VDC / 0 to 100% Used for setting signal (PID process command value) or feedback signal. Connects PTC thermistor for motor protection.  Used as additional auxiliary setting to various frequency settings. The peripheral analog signal can be displayed on the keypad. (Displaying coefficient: valid)	Input impedance: 22kΩ Maximum input: +15VDC
	[11]	Analog common	Common terminal for frequency setting signals ([12], [13], [C1], [V2], [FMA], [FMI]). Two terminals are provided.	Isolated from terminals [CM] and [CMY].
	Digital input	[X1]	Digital input 1	The following functions can be set at terminals [X1] to [X5], [FWD] and [REV] for signal input.  <Common function> • Sink and source are changeable using the built-in sliding switch. • ON timing can be changed between short-circuit of terminals [X1] and [CM] and open circuits of them. The same setting is possible between [CM] and any of the terminals among [X2], [X3], [X4], [X5], [FWD], and [REV].
[X2]		Digital input 2		
[X3]		Digital input 3		
[X4]		Digital input 4		
[X5]		Digital input 5		
[FWD]		Forward operation command		
[REV]		Reverse operation command		

Symbol	Terminal name	Functions	Remarks
(FWD)	Forward operation command	The motor runs in the forward direction upon ON across (FWD) and [CM]. The motor decelerates and stops upon OFF.	This function can be set only for the terminals [FWD] and [REV].
(REV)	Reverse operation command	The motor runs in the reverse direction upon ON across (REV) and [CM]. The motor decelerates and stops upon OFF.	
(SS1) (SS2) (SS4)	Multistep freq. selection	8-step operation can be conducted with ON/OFF signals at (SS1) to (SS4).	
(HLD)	3-wire operation stop command	Used for 3-wire operation. ON across (HLD) and [CM]: The inverter self-holds FWD or REV signal. OFF across (HLD) and [CM]: The inverter releases self-holding.	
(BX)	Coast-to-stop command	ON across (BX) and [CM]: The inverter output is shut off immediately and the motor coasts to a stop.	No alarm signal will be output.
(RST)	Alarm reset	ON across (RST) and [CM]: Faults are reset.	Alarm reset signal width: 0.1(s) or more
(THR)	Trip command (External fault)	OFF across (THR) and [CM]: The inverter output is shut off immediately and the motor coasts-to-stop.	Alarm signal OH2 will be output.
(Hz2/Hz1)	Freq. set 2 /Freq. set 1	ON across (Hz2/Hz1) and [CM]: Freq. set 2 is effective.	
(DCBRK)	braking command	ON across (DCBRK) and [CM]: Starts DC braking action.	
(SW50)	Line/inverter switch(50Hz)	OFF across (SW50) and [CM]: Starts at 50Hz.	
(SW60)	Line/inverter switch(60Hz)	OFF across (SW60) and [CM]: Starts at 60Hz	
(UP)	UP command	The output frequency rises while the circuit across (UP) and [CM] is connected.	
(DOWN)	DOWN command	The output frequency drops while the circuit across (DOWN) and [CM] is connected.	
(WE-KP)	Write enable for KEYPAD	The function code data can be changed from the keypad only when (WEE-KP) is ON.	
(Hz/PID)	PID cancel	PID control can be canceled when the circuit across (Hz/PID) and [CM] is connected. (Operation proceeds according to the selected frequency setting method such as the multi-step frequency, keypad and analog input.)	
(IVS)	Inverse mode changeover	The frequency setting or PID control output signal (frequency setting) action mode switches between normal and inverse actions when the circuit across (IVS) and [CM] is connected.	
(IL)	Interlock	Connect an auxiliary contact of a switch installed between the inverter and motor. This signal is input upon momentary power failure to detect momentary power failure, and the inverter restarts upon power recovery.	
(LE)	Link enable (RS-485, Bus)	Operation proceeds according to commands sent via RS-485 communication or field bus (option) when the circuit across (LE) and [CM] is connected.	
(U-DI)	Universal DI	An arbitrary digital input signal is transmitted to the host controller.	
(STM)	Starting characteristic selection	ON across (STM) and [CM]: Starting at the pick-up frequency becomes valid.	
(STOP)	Forcible stop	ON across (STOP) and [CM]: The inverter is forcibly stopped in the special deceleration time.	
(PID-RST)	PID differentiation / integration reset	ON across (PID-RST) and [CM]: Resets differentiation and integration values of PID.	
(PID-HLD)	PID integral hold	ON across (PID-HLD) and [CM]: Holds integration values of PID.	
(LOC)	Local (keypad) command selection	ON across (LOC) and [CM]: The operation commands and frequency settings given at the keypad become valid.	
(RE)	Operation permission	After an operation command is input, operation starts upon activation of (RE).	

Digital input

	Symbol	Terminal name	Functions	Remarks
Digital input	(DWP)	Dew prevention	ON across (DWP) and [CM]: A current flows through the motor to avoid motor temperature drop during inverter stoppage so that condensation will not occur.	
	(ISW50)	Line/inverter switching sequence(50Hz)	OFF across (ISW50) and [CM]: Line operation starts according to the switching sequence built in the inverter. (For 50Hz commercial line)	
	(ISW60)	Line/inverter switching sequence(60Hz)	OFF across (ISW60) and [CM]: Line operation starts according to the switching sequence built in the inverter. (For 60Hz commercial line)	
	(FR2/FR1)	Operation command 2/1	ON across (FR2/FR1) and [CM]: The operation command switches to (FWD2) (REV2) side.	
	(FWD2)	Forward rotation/stop command 2	Forward operation upon ON across (FWD) and [CM]. Deceleration and stop upon OFF. (Second operation command)	
	(REV2)	Reverse operation/stop command 2	Reverse operation upon ON across (REV) and [CM]. Deceleration and stop upon OFF. (Second operation command)	
	[PLC]	PLC terminal	Connect to PLC output signal power supply. Common for 24V power.	+24V(+22 to +27V) 50mA max.
	[CM]	Common	Common terminal for digital input signal Two terminals are provided	Isolated from terminals [11] and [CMY].
Transistor output	(PLC)	Transistor output power	Power supply for a transistor output load.(+24VDC 50mADC Max.) (Note: Same terminal as digital input [PLC] terminal) Short circuit across terminals [CM] and [CMY] to use.	
	[Y1]	Transistor output 1	The following functions can be set at terminals [Y1] to [Y3] for signal output. • The setting of "short circuit upon active signal output" or "open upon active signal output" is possible. • Sink/source support (switching unnecessary)	Max. voltage: 27VDC, max. current: 50mA, leak current: 0.1mA max., ON voltage: within 2V (at 50mA)
	[Y2]	Transistor output 2		
	[Y3]	Transistor output 3		
	(RUN)	Inverter running (speed exists)	An active signal is issued when the inverter runs at higher than the starting frequency.	
	(RUN2)	Inverter output on	A signal is issued when the inverter runs at smaller than the starting frequency or when DC braking is in action	
	(FAR)	Speed/freq. arrival	An active signal is issued when the output frequency reaches the set frequency.	Detection width (fixed): 2.5 (Hz)
	(FDT)	Speed/freq. detection	An active signal is issued at output frequencies above a preset detection level. The signal is deactivated if the output frequency falls below the detection level.	Hysteresis width (fixed): 0.0 to 120.0(Hz)
	(LU)	Undervoltage detection	The signal is output when the inverter stops because of undervoltage.	
	(IOL)	Inverter output limit (limit on current)	The signal is output when the inverter is limiting the current.	
	(IPF)	Auto-restarting	The signal is output during auto restart operation (after momentary power failure and until completion of restart).	
	(OL)	Overload early warning (motor)	The signal is output when the electronic thermal relay value is higher than the preset alarm level.	
	(RDY)	Operation ready output	A signal is issued if preparation for inverter operation is completed.	
(SW88)	Line-to-inverter switching	The magnetic contactor on the line side of line-to-inverter switching is controlled.		

	Symbol	Terminal name	Functions	Remarks
Digital input	(SW52-2)	Line-to-inverter switching	The magnetic contactor on the inverter output side (secondary side) of line-to-inverter switching is controlled.	
	(SW52-1)	Line-to-inverter switching	The magnetic contactor on the inverter input side (primary side) of line-to-inverter switching is controlled.	
	(AX)	AX terminal function	The electromagnetic contactor on the inverter input side (primary side) is controlled.	
	(FAN)	Cooling fan ON/OFF control	The ON/OFF state signal of the cooling fan is issued.	
	(TRY)	Retry in action	The signal is output during an active retry.	
	(U-DO)	Universal DO	The signal transmitted from the host controller is issued.	
	(OH)	Heat sink overheat early warning	An early warning signal is issued before the heat sink trips due to an overheat. For models of 50HP or above in 208 V, 75HP or above in 460 V, a 'OH' signal outputs by setting H98 bit5 to '1' and detecting a failure of the internal circulation fan.	
	(LIFE)	Lifetime alarm	Outputs alarm signal according to the preset lifetime level. For models of 50HP or above in 208 V, 75HP or above in 460 V, a 'LIFE' signal outputs by detecting a failure of the internal circulation fan.	
	(REF OFF)	Command loss detection	A loss of the frequency command is detected to issue a signal.	
	(OLP)	Overload preventive control	The signal is output when while the overload preventive control is activated.	
	(ID)	Current detection	The signal is output when a current larger than the set value has been detected for the timer-set time.	
	(PID-ALM)	alarm output	An absolute value alarm or deviation alarm under PID control is issued as a signal.	
	(PID-CTL)	Under PID control	The valid state of PID control is issued as a signal.	
	(PID-STP)	PID stop upon small water flow	A signal is issued if operation is stopped due to a small water flow under PID control. (The inverter is stopped even if the operation command is issued.)	
	(U-TL)	Low torque detection	A signal is issued if the torque falls below the preset low torque detection level for a set timer time.	
	(RMT)	In remote mode	A signal is issued in the remote mode.	
	(AX2)	Operation command input	A signal is issued if there is an operation command input and operation ready is completed.	
	(ALM)	Alarm relay output (for any fault)	An alarm relay output (for any fault) signal is issued as a transistor output signal.	
(C1OFF)	Terminal C1 off signal	The signal is output when the input current of terminal [C1] is less than 2mA.		
	[CMY]	Transistor output common	Common terminal for transistor output	The terminal is isolated from terminals [11] and [CM].
Contact output	Y5A, Y5C	General-purpose relay output	<ul style="list-style-type: none"> <li>Multi-purpose relay output; signals similar to above-mentioned signals [Y1] to [Y3] can be selected.</li> <li>An alarm output is issued upon either excitation or no excitation according to selection.</li> </ul>	Contact capacity: 250VAC, 0.3A, $\cos\phi = 0.3$ +48VDC, 0.5A
	30A, 30B, 30C	Alarm relay output (for any fault)	<ul style="list-style-type: none"> <li>A no-voltage contact signal (1c) is issued when the inverter is stopped due to an alarm.</li> <li>Multi-purpose relay output; signals similar to above-mentioned signals [Y1] to [Y3] can be selected.</li> <li>An alarm output is issued upon either excitation or no excitation according to selection.</li> </ul>	

	Symbol	Terminal name	Functions	Remarks
Analog output	[FMA]	Analog monitor	<p>The output style can be selected between DC voltage (0 to +10V) and DC current (+4 to +20mA).</p> <p>One of the following items can be output in the selected output style.</p> <ul style="list-style-type: none"> <li>• Output frequency</li> <li>• Output torque.</li> <li>• PID feedback value.</li> <li>• Motor output.</li> <li>• PID command.</li> <li>• Output current.</li> <li>• Load factor.</li> <li>• DC link circuit voltage.</li> <li>• Analog output test.</li> <li>• PID output</li> <li>• Output voltage.</li> <li>• Input power.</li> <li>• Universal AO.</li> </ul> <p>In the case of voltage output, up to two analog voltmeters (0 to +10Vdc, input impedance: 10kΩ) can be connected.</p> <p>In the case of current output, analog ammeters (up to 500Ω) can be connected.</p> <p>Gain adjustment range: 0 to 200%</p>	
	[FMI]	Analog monitor 2	<p>One of the following items can be output in a DC current (+4 to +20mA) .</p> <ul style="list-style-type: none"> <li>• Output frequency</li> <li>• Output torque.</li> <li>• PID feedback value.</li> <li>• Motor output.</li> <li>• PID command.</li> <li>• Output current.</li> <li>• Load factor.</li> <li>• DC link circuit voltage.</li> <li>• Analog output test.</li> <li>• PID output</li> <li>• Output voltage.</li> <li>• Input power.</li> <li>• Universal AO.</li> </ul> <p>Analog ammeters (up to 500Ω) can be connected.</p> <p>Gain adjustment range: 0 to 200%</p>	
Communication	—	RJ45 connector for connection of keypad	<p>One of the following protocols can be selected.</p> <ul style="list-style-type: none"> <li>• Modbus RTU</li> <li>• Protocol exclusively for keypad (default selection)</li> <li>• SX protocol for PC loader</li> <li>• Metasys-N2</li> <li>• FLN P1</li> </ul>	Power (+5V) is supplied to the keypad.
	—	Field bus communication	<p>Applicable from the following.</p> <p>OPC-F1-PDP: PROFIBUS DP interface card  OPC-F1-DEV: DeviceNet interface card  OPC-F1-LNW: LONWORKS interface card  OPC-F1-CCL: CC-Link interface card  OPC-F1-BAC: BACnet interface card  OPC-F1-ETH: Ethernet (wired) interface card  OPC-F1-WiE: Ethernet (wireless) interface card</p> <p>Ethernet communication cards include the following protocols:</p> <ul style="list-style-type: none"> <li>• Ethernet/IP</li> <li>• Modbus/TCP</li> <li>• BACnet/IP</li> <li>• Profinet/IO Wireless Only</li> </ul>	Field bus card is option.
Built-in card	[DX+] [DX-] [SD]	RS-485 communication terminals (OPC-F1-RS)	This card makes communication with a PLC or personal computer system easy.	

## 4. Basic wiring diagram (Operation by external signal inputs)

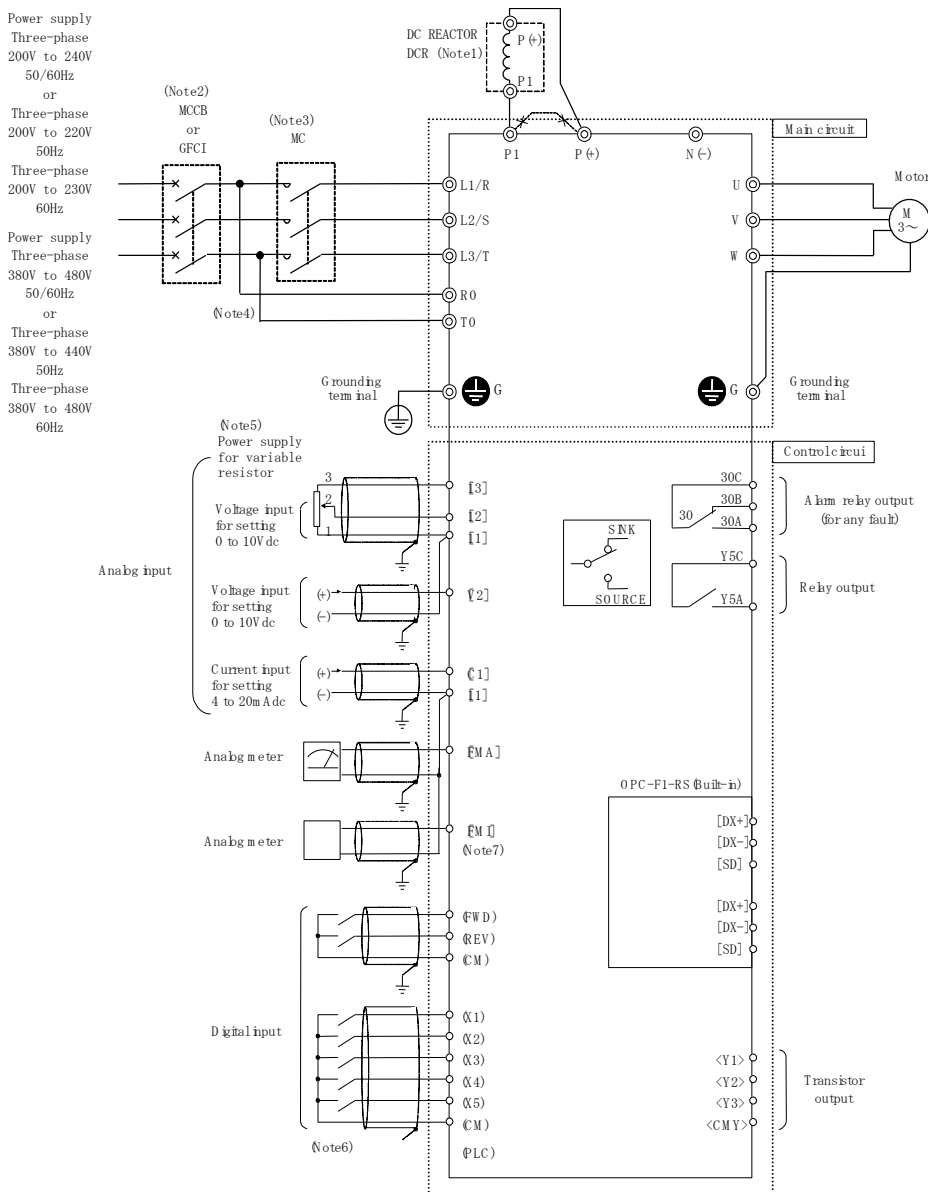

### Note1:

When connecting a DC reactor (DCR) (option), remove the jumper bar from across the terminals [P1] and [P(+)]. The DCR is a standard accessory for 75HP 208V or larger, 100HP 460V or larger capacity inverters. Connect it without fail.

### Note2:

Install a recommended molded-case circuit-breaker (MCCB) or a ground fault circuit interrupter (GFCI) (with an overcurrent protection function) in the primary circuit of the inverter to protect wiring. At this time, ensure that the circuit breaker capacity is equivalent to or lower than the recommended capacity.

### Note3:

Install a magnetic contactor (MC) recommended for each inverter to separate the inverter from the power supply, apart from the MCCB or GFCI, when necessary. Connect a surge suppressor in parallel when installing a coil such as the MC or solenoid near the inverter.

### Note4:

Connect to operate only the control circuit with the main circuit power supply open and to bring the inverter in a waiting state. Even if this terminal is not connected, the inverter can be operated with connection of the main circuit.

### Note5:

Frequency can be set by connecting a frequency setting device (external potentiometer) among the terminals [11], [12] and [13] instead of inputting voltage signal (0 to +10VDC, 0 to +5VDC or +1 to +5VDC) between the terminals [12] and [11].

### Note6:

For the control signal wires, use shielded or twisted wires. Ground shielded wires. To prevent malfunction due to noise, keep the control circuit wiring away from the main circuit wiring as far as possible (recommended: 10cm or more), and never set them in the same wire duct. When crossing the control circuit wiring with the main circuit wiring, set them at right angles.

### Note 7:

Connect this wire to [11] for [FMI].



## Standard Models:

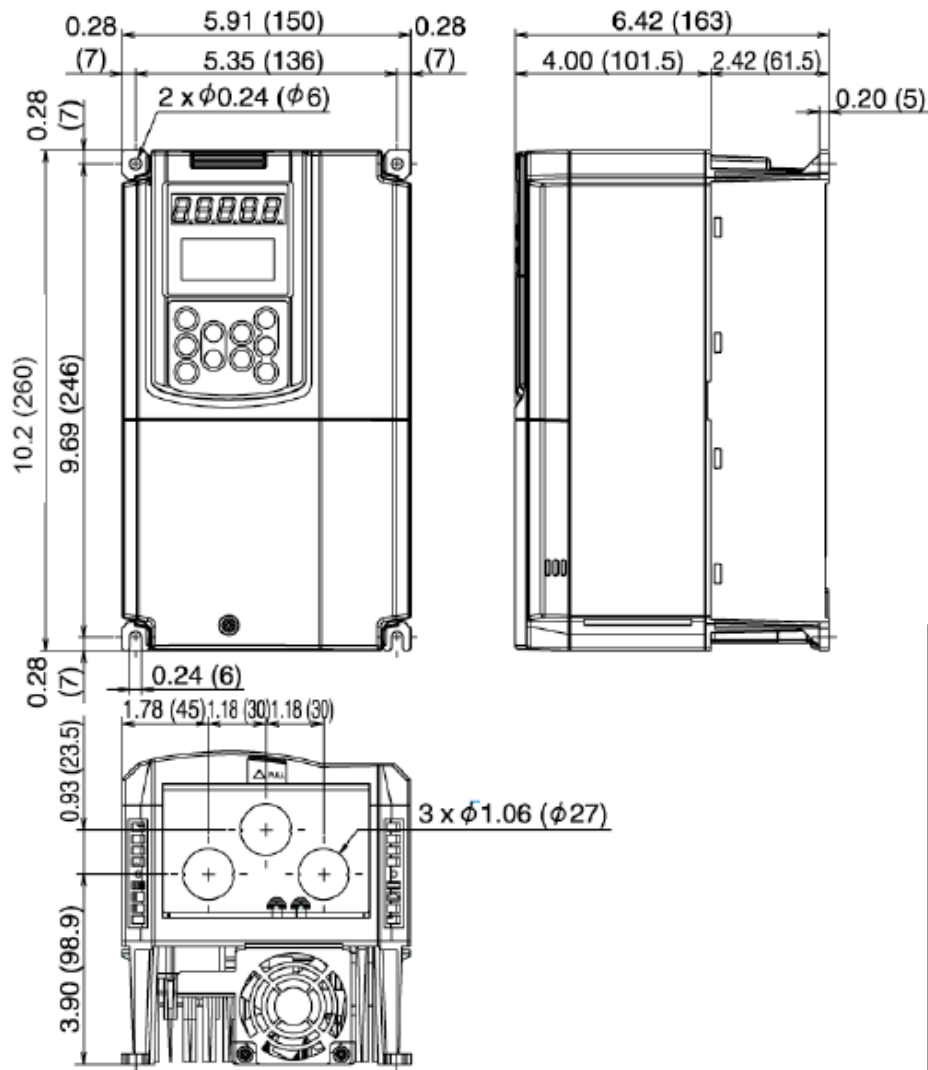

Power supply voltage	Type
Three-phase 208 V	FRN001F1S-2U
	FRN002F1S-2U
	FRN003F1S-2U
	FRN005F1S-2U
Three-phase 460 V	FRN001F1S-4U
	FRN002F1S-4U
	FRN003F1S-4U
	FRN007F1S-4U



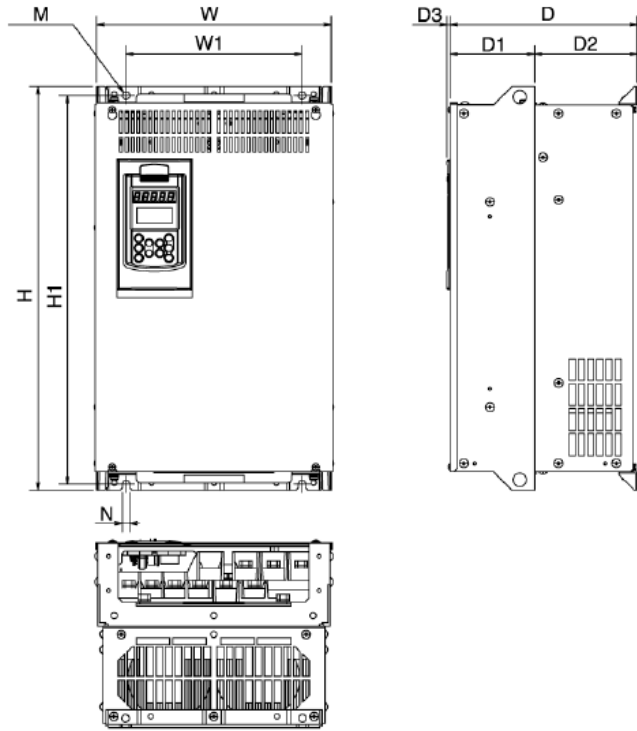

Power supply voltage	Type	Dimensions [inch (mm)]									
		W	W1	H	H1	D	D1	D2	D3	M	N
Three-phase 208 V	FRN040F1S-2U	12.6 (320)	9.45 (240)	21.7 (550)	20.9 (530)	10.0 (255)	4.53 (115)	5.51 (140)	0.18 (4.5)	2x $\phi$ 0.39 (2x $\phi$ 10)	0.39 (10)
	FRN050F1S-2U	14.0 (355)	10.8 (275)	24.2 (615)	23.4 (595)	10.6 (270)		6.10 (155)			
	FRN060F1S-2U			29.1 (740)	28.3 (720)		5.51 (140)				
	FRN075F1S-2U			26.8 (680)	22.8 (580)		34.6 (880)	33.5 (850)	15.6 (395)	10.0 (255)	0.24 (6)
	FRN100F1S-2U	26.8 (680)	22.8 (580)	34.6 (880)	33.5 (850)	15.6 (395)	10.0 (255)	0.24 (6)	3x $\phi$ 0.59 (3x $\phi$ 15)	0.59 (15)	
Three-phase 460 V	FRN050F1S-4U	12.6 (320)	9.45 (240)	21.7 (550)	20.9 (530)	10.0 (255)	4.53 (115)	5.51 (140)	0.18 (4.5)	2x $\phi$ 0.39 (2x $\phi$ 10)	0.39 (10)
	FRN060F1S-4U	14.0 (355)	10.8 (275)	24.2 (615)	23.4 (595)	10.6 (270)		6.10 (155)			
	FRN075F1S-4U			29.1 (740)	28.3 (720)		11.8 (300)	5.71 (145)	6.10 (155)		
	FRN100F1S-4U			29.1 (740)	28.3 (720)		11.8 (300)	5.71 (145)	6.10 (155)	0.24 (6)	2x $\phi$ 0.39 (2x $\phi$ 10)
	FRN125F1S-4U	20.9 (530)	16.9 (430)	29.1 (740)	28.0 (710)	12.4 (315)	5.31 (135)	7.09 (180)			
	FRN150F1S-4U			39.4 (1000)	38.2 (970)	14.2 (360)	7.09 (180)	7.09 (180)			
	FRN200F1S-4U	20.9 (530)	16.9 (430)	29.1 (740)	28.0 (710)	12.4 (315)	5.31 (135)	7.09 (180)	0.24 (6)	2x $\phi$ 0.39 (2x $\phi$ 10)	0.39 (10)
	FRN250F1S-4U			39.4 (1000)	38.2 (970)	14.2 (360)	7.09 (180)	7.09 (180)			
	FRN300F1S-4U	26.8 (680)	22.8 (580)	39.4 (1000)	38.2 (970)	15.0 (380)	7.87 (200)	7.09 (180)	0.24 (6)	3x $\phi$ 0.59 (3x $\phi$ 15)	0.59 (15)
	FRN350F1S-4U			55.1 (1400)	53.9 (1370)	17.3 (440)	10.2 (260)				
	FRN400F1S-4U										
	FRN450F1S-4U	34.6 (880)	30.7 (780)	55.1 (1400)	53.9 (1370)	17.3 (440)	10.2 (260)	7.09 (180)	0.24 (6)	3x $\phi$ 0.59 (3x $\phi$ 15)	0.59 (15)
	FRN500F1S-4U			55.1 (1400)	53.9 (1370)	17.3 (440)	10.2 (260)				
	FRN600F1S-4U	34.6 (880)	30.7 (780)	55.1 (1400)	53.9 (1370)	17.3 (440)	10.2 (260)	7.09 (180)	0.24 (6)	3x $\phi$ 0.59 (3x $\phi$ 15)	0.59 (15)
	FRN700F1S-4U			55.1 (1400)	53.9 (1370)	17.3 (440)	10.2 (260)				
FRN800F1S-4U	55.1 (1400)			53.9 (1370)	17.3 (440)	10.2 (260)					
FRN900F1S-4U	34.6 (880)	30.7 (780)	55.1 (1400)	53.9 (1370)	17.3 (440)	10.2 (260)	7.09 (180)	0.24 (6)	4x $\phi$ 0.59 (4x $\phi$ 15)	0.59 (15)	

# Multi-function Keypad

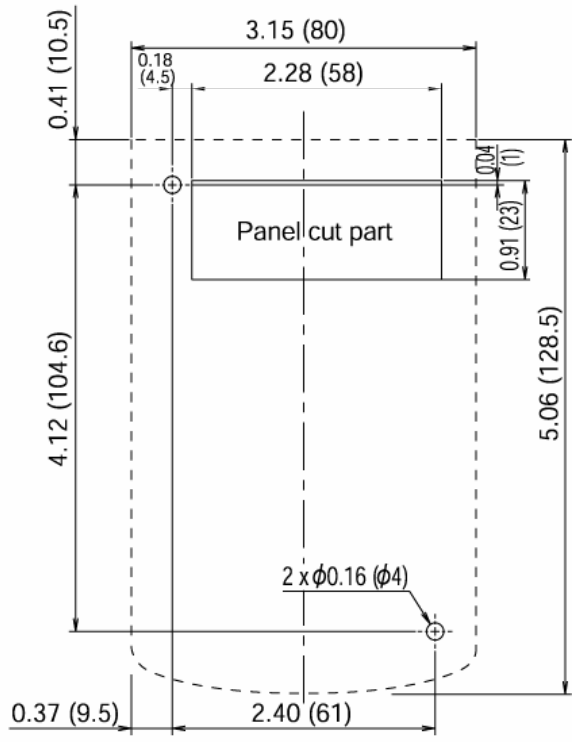
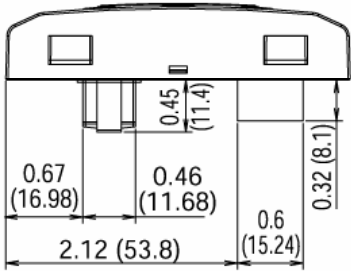
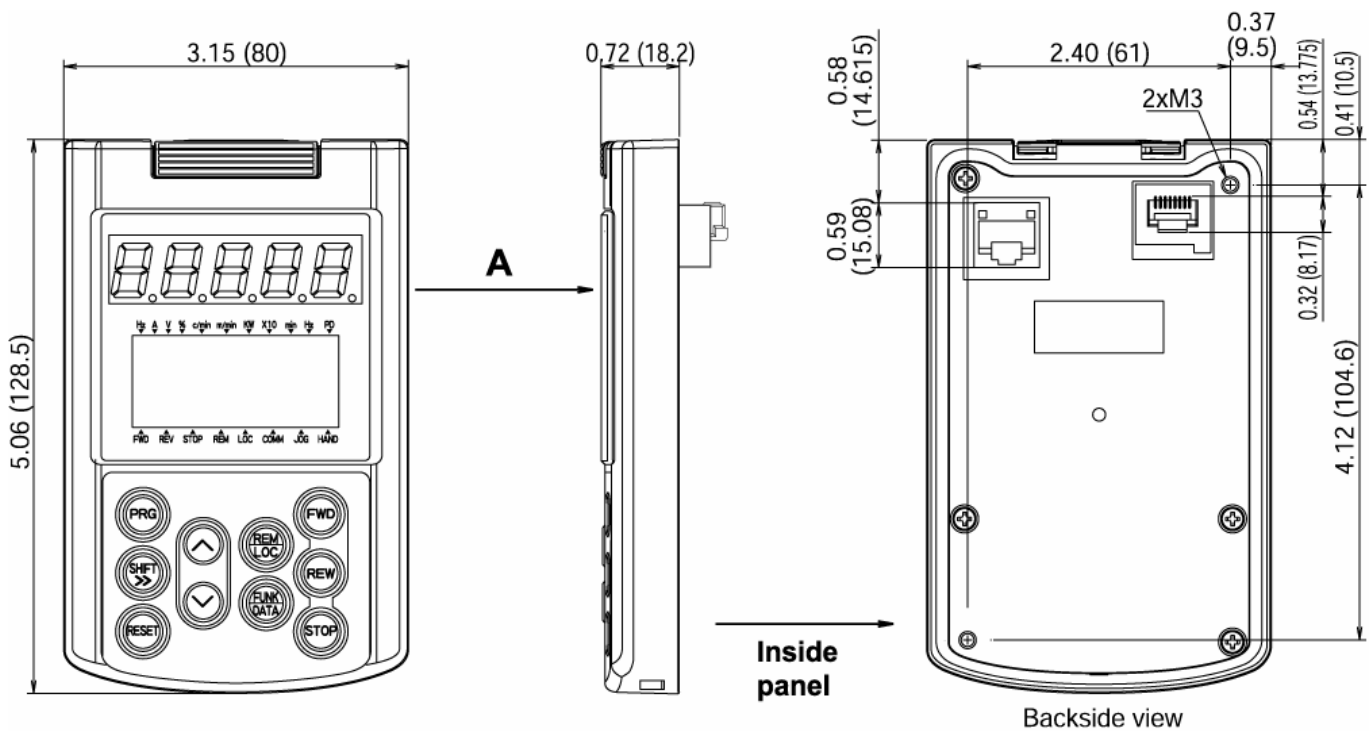

Dimensions of panel cutting (viewed from "A")